











CMOS Digital Integrated Circuit Silicon Monolithic

TMPM3H Group(1)

General Description

- Arm® Cortex®-M3 core. Operation frequency: 1 to 40 MHz.
Operation voltage: 2.7 to 5.5V
- Code flash: 32 to 128KB. Data flash: 8 to 32KB.
- Package: 32-pin to 100-pin. 11 types of packages are available.

	VQFN48	6x6mm	0.4mm pitch
	LQFP32	7x7mm	0.8mm pitch
	LQFP48	7x7mm	0.5mm pitch
	LQFP44	10x10mm	0.8mm pitch
	LQFP52	10x10mm	0.65mm pitch
	LQFP64	10x10mm	0.5mm pitch
	LQFP64	14x14mm	0.8mm pitch
	LQFP80	12x12mm	0.5mm pitch
	LQFP80	14x14mm	0.65mm pitch
	LQFP100	14x14mm	0.5mm pitch
	QFP100	14x20mm	0.65mm pitch

Applications

Widely used for consumer products and industrial products including home appliances, OA equipment, household equipment, AV devices, and motor control devices.

Features

- Arm Cortex-M3 core
 - Operation frequency: 1 to 40 MHz
 - Memory Protection Unit (MPU)
- Low-power consumption mode
 - Operation voltage: 2.7 to 5.5V
 - 100µA/MHz (at basic operation)
 - Low-power consumption operation: IDLE, STOP1, STOP2
- Operation temperature: -40 to +85°C
- Internal memory
 - Code flash: 32 to 128 KB, rewritable up to 10,000 times
 - Data flash: 8 to 32 KB, rewritable up to 100,000 times
 - Data flash is rewritable in parallel with instruction execution
 - RAM: 6 to 16KB and Backup RAM 2 KB
- Clock
 - External high-speed oscillator: 6 MHz to 12 MHz(Ceramic, Crystal)
 - External high-speed clock input: 6 to 20 MHz
 - Internal high-speed oscillator (IHOSC1): 10 MHz, user trimming function
 - PLL: 40 MHz output
 - External low-speed oscillator: 32.768kHz
- Oscillation frequency detection (OFD): Abnormal system clock detection
- Low-Voltage Detection (LVD): 8 level, Generate interrupts and reset outputs
- Interruption
 - External: 6 to 16 factors, with DNF
 - internal: 85 to 100 factors
- I/O ports: GPIO:24 to 87(Input:2 to 4,Output:1)
 - pull-up/-down resistor, Open-drain, 5V-tolerant
- On chip Debug(JTAG/SW)
- Trigger Selector(TRGSEL)
 - Expand Trigger request for DMAC, Timer, others
- DMA Controller(DMAC)
 - DMA requests: 32 factors, internal/external triggers
- Asynchronous Serial Interface(UART): 2 to 3 channels
 - 2.5Mbps(Max),FIFO(Send 8stage, Receive 8stage)
- Serial Peripheral Interface(TSPI): 1 to 2 channels
 - SIO/SPI mode,20Mbps(MAX),FIFO(Send 16bitsx8,Receive 16bitsx8)
- I²C Interface(I²C):1 to 3 channels
 - Multi Master, Fm+, Release function for Low Power Mode
- 8-bit DA converter(DAC): 0 to 2 channels
- 12-bit ADC(ADC): 4 to 16 channel inputs
 - Sample-and-hold circuit
 - Conversion time: 1.5µs@40MHz
 - Self-diagnosis support function
- Motor control circuit (PMD+): 1 channel
 - 3 phase PWM output, Synchronized with 12-bit ADC
 - Emergency stop function by external inputs (EMG_N pin, OVV_N pin)
- Advanced Encoder input circuit (A-ENC): 1 channel
 - Encoder/sensor (3 types)/Timer /Phase counter mode
- 32bit Timer Event Counter (T32A)
 - 12 channels as 16-bit Timers:6 channels as 32-bits Timers
 - Interval Timer, event counter, input capture, phase difference input, PPG output, Sync Start, Trigger Start
- Realtime Clock (RTC): 0 to 1 channel
- Watchdog timer (SIWDT): 1 channel
 - Clock system other than the system clock can be selected,
 - Clear window, interrupts and reset output
- Remote controller reception circuit (RMC): 1 channel
- Supports boundary scan(BSC)

Start of commercial production
2017-06

Products Lists Categorized by Functions

The product under development is contained in this table.
For the newest status of each product, Please contact your sales representative.

Table 1 Products Lists (1)

Built-in Functions		TMPM3H6FWFG TMPM3H6FUFG TMPM3H6FSFG	TMPM3H6FWDFG TMPM3H6FUDFG TMPM3H6FSDFG	TMPM3H5FWFG TMPM3H5FUFG TMPM3H5FSFG	TMPM3H5FWDFG TMPM3H5FUDFG TMPM3H5FSDFG	TMPM3H4FWUG TMPM3H4FUUG TMPM3H4FSUG	TMPM3H4FWFG TMPM3H4FUFG TMPM3H4FSFG
Memory	Code Flash (KB)	128	128	128	128	128	128
		96	96	96	96	96	96
		64	64	64	64	64	64
	Data Flash (KB)	32	32	32	32	32	32
32		32	32	32	32	32	
16		16	16	16	16	16	
RAM (KB)	16	16	16	16	16	16	16
	12	12	12	12	12	12	12
	8	8	8	8	8	8	8
Backup RAM (KB)	2	2	2	2	2	2	2
I/O port	PORT (Pin)	87	87	67	67	53	53
External interrupt	INT (Pin)	16	16	15	15	11	11
DMA	DMAC (Ch)	32	32	32	32	32	32
Timer function	T32A (Ch)	6	6	6	6	6	6
	RTC (Ch)	1	1	1	1	1	1
Serial communication function	UART (Ch)	3	3	3	3	3	3
	I ² C (Ch)	3	3	3	3	3	3
	TSPI (Ch)	2	2	2	2	2	2
Analog function	12-bit ADC (Ch)	16	16	10	10	8	8
	8-bit DAC (Ch)	2	2	2	2	1	1
Motor Control peripherals	A-ENC (Ch)	1	1	1	1	1	1
	PMD+ (Ch)	1	1	1	1	1	1
Remote Control Receiver peripherals	RMC (Ch)	1	1	1	1	1	1
System function	LVD (Ch)	1	1	1	1	1	1
	SIWDT (Ch)	1	1	1	1	1	1
	OFD (Ch)	1	1	1	1	1	1
	POR	1	1	1	1	1	1
Debug interface	Debug	JTAG/SW/ TRACE	JTAG/SW	JTAG/SW	JTAG/SW	JTAG/SW	JTAG/SW
BSC		1	1	1	1	1	1
Package	Package type	LQFP100 (14mm x 14mm, 0.5 mm pitch)	QFP100 (14mm x 20mm, 0.65 mm pitch)	LQFP80 (12mm x 12mm, 0.5 mm pitch)	LQFP80 (14mm x 14mm, 0.65 mm pitch)	LQFP64 (10mm x 10mm, 0.5 mm pitch)	LQFP64 (14mm x 14mm, 0.8 mm pitch)
	Package name	LQFP100-P-1414 -0.50H	P-QFP100-1420 -0.65-001	LQFP80-P-1212 -0.50F	P-LQFP80-1414 -0.65-001	LQFP64-P-1010 -0.50E	P-LQFP64-1414 0.80-002

Table 2 Products Lists (2)

Built-in functions		TMPM3H3FWUG TMPM3H3FUUG TMPM3H3FSUG	TMPM3H2FWDUG TMPM3H2FUDUG TMPM3H2FSDUG	TMPM3H2FWQG TMPM3H2FUQG TMPM3H2FSQG	TMPM3H1FWUG TMPM3H1FUUG TMPM3H1FSUG TMPM3H1FPUG	TMPM3H0FSDUG TMPM3H0FMDUG
Memory	Code Flash (KB)	128 96 64	128 96 64	128 96 64	128 96 64 48	64 32
	Data Flash (KB)	32 32 16	32 32 16	32 32 16	32 32 16 8	16 8
	RAM (KB)	16 12 8	16 12 8	16 12 8	16 12 8 6	8 6
	Backup RAM (KB)	2	2	2	2	2
I/O port	PORT (Pin)	43	40	40	36	24
External interrupt	INT (Pin)	8	7	7	6	6
DMA	DMAC (Ch)	32	30	30	30	24
Timer function	T32A (Ch)	6	6	6	6	6
	RTC (Ch)	1	1	1	0	0
Serial communication function	UART (Ch)	3	3	3	3	2
	I ² C (Ch)	3	2	2	2	1
	TSPI (Ch)	2	2	2	2	1
Analog function	12-bit ADC (Ch)	8	8	8	8	4
	8-bit DAC (Ch)	1	1	1	0	0
Motor Control peripherals	A-ENC (Ch)	1	1	1	1	1
	PMD+ (Ch)	1	1	1	1	1
Remote Control Receiver peripherals	RMC (Ch)	1	1	1	1	1
System function	LVD (Ch)	1	1	1	1	1
	SIWDT (Ch)	1	1	1	1	1
	OFD (Ch)	1	1	1	1	1
	POR	1	1	1	1	1
Debug interface	Debug	JTAG/SW	JTAG/SW	JTAG/SW	JTAG/SW	SW
BSC		1	0	0	0	0
Package	Package type	LQFP52 (10mm x 10mm, 0.65 mm pitch)	LQFP48 (7mm x 7mm, 0.5 mm pitch)	VQFN48 (6mm x 6mm, 0.4 mm pitch)	LQFP44 (10mm x 10mm, 0.8 mm pitch)	LQFP32 (7mm x 7mm, 0.8 mm pitch)
	Package name	P-LQFP52-1010 -0.65-001	LQFP48-P-0707 -0.50C	P-VQFN48-0606 -0.40-003	LQFP44-P-1010 -0.80A	P-LQFP32-0707 -0.80-002

Contents

General Description.....	1
Applications	1
Features	1
Products Lists Categorized by Functions.....	2
Contents	4
List of Figures	7
List of Tables	7
Preface	9
Conventions.....	9
Terms and Abbreviations.....	11
1. Block Diagram.....	12
2. Pin Assignment.....	13
2.1. LQFP100	13
2.2. QFP100	14
2.3. LQFP80	15
2.4. LQFP64	16
2.5. LQFP52	17
2.6. LQFP48	18
2.7. VQFN48.....	19
2.8. LQFP44	20
2.9. LQFP32	21
3. Memory Map	22
3.1. List of Memory Sizes	23
4. Pin Description.....	24
4.1. Functional Pin Name and Their Functions.....	24
4.1.1. Peripheral Function Pins	24
4.1.2. Debug Pins	26
4.1.3. Control Pins	27
4.1.4. Power Supply Pins	28
4.1.5. Capacitors between power supply pins	29
4.2. Functional Pin and Ports Assignment (Pin Number)	30
4.3. Ports	41
4.3.1. Port Specification Table.....	42
5. Functional Description and Operation Description	45
5.1. Reference Manuals	45
5.2. Processor Core.....	46
5.2.1. Core Information.....	46
5.2.2. Configurable Options.....	46
5.3. Clock Control and Operation mode (CG).....	47

5.4. Flash Memory (Code FLASH, Data FLASH)	47
5.5. Oscillation Circuit.....	48
5.6. Trimming Circuit (TRM)	48
5.7. Oscillation Frequency Detection Circuit (OFD)	48
5.8. Voltage Detection Circuit (LVD)	49
5.9. Digital Noise Filter (DNF)	49
5.10. Debug Interface (DEBUG).....	50
5.11. DMA Controller (DMAC).....	51
5.12. Asynchronous Serial Communication Circuit (UART)	51
5.13. Serial Peripheral Interface (TSPI)	51
5.14. I ² C Interface (I ² C)	52
5.15. 8-bit Digital-to-Analog Converter (DAC).....	52
5.16. 12-bit Analog-to-Digital Converter (ADC).....	53
5.17. Motor Control Circuit Plus (PMD+).....	53
5.18. Advanced Encoder Input Circuit (A-ENC).....	53
5.19. 32-bit Timer Event Counter (T32A)	54
5.20. Real Time Clock (RTC)	54
5.21. Clock Selective Watchdog Timer (SIWDT)	55
5.22. Remote signal receive Circuit (RMC).....	55
5.23. Boundary Scan (BSC)	55
6. Equivalent Circuit.....	56
6.1. Port	56
6.2. Analog Power pin	60
6.3. Control Pin	61
6.4. Clock control.....	62
7. Electrical Characteristics.....	63
7.1. Absolute Maximum Ratings.....	63
7.2. DC Electrical Characteristics (1/2)	64
7.3. DC Electrical Characteristics (2/2)	68
7.4. 12-bit AD Converter Characteristics.....	70
7.5. 8-bit DA Converter Characteristics.....	71
7.6. Characteristics of Internal processing at RESET	72
7.7. Characteristics of Power-on Reset.....	72
7.8. Characteristics of Voltage Detection Circuit.....	73
7.9. AC Electrical Characteristics	74
7.9.1. Serial Peripheral Interface (TSPI).....	74
7.9.2. I ² C Interface (I ² C)	79
7.9.3. 32-bit Timer Event Counter (T32A).....	81
7.9.4. External Interrupt.....	82
7.9.5. Trigger Input (TRGINx).....	83

7.9.6. Debug Communication	84
7.9.7. SCOUT Pin.....	87
7.9.8. Noise Filter Characteristics.....	87
7.9.9. External Clock Input	88
7.10. Flash Memory Characteristics.....	89
7.10.1. Code Flash.....	89
7.10.2. Data Flash	89
7.10.3. Chip Erase.....	89
7.11. Regulator	90
7.12. Oscillation Circuit.....	90
7.12.1. Internal Oscillator.....	90
7.12.2. External Oscillator	90
7.12.3. Oscillation Circuit.....	91
7.12.4. Ceramic Oscillator	91
7.12.5. Crystal Oscillator	91
7.12.6. Precautions for designing printed circuit board.....	91
8. Package Dimensions	92
8.1. LQFP100-P-1414-0.50H	92
8.2. P-QFP100-1420-0.65-001	93
8.3. LQFP80-P-1212-0.50F.....	94
8.4. P-LQFP80-1414-0.65-001	95
8.5. LQFP64-P-1010-0.50E.....	96
8.6. P-LQFP64-1414-0.80-002.....	97
8.7. P-LQFP52-1010-0.65-001	98
8.8. LQFP48-P-0707-0.50C	99
8.9. P-VQFN48-0606-0.40-003	100
8.10. LQFP44-P-1010-0.80A.....	101
8.11. P-LQFP32-0707-0.80-002.....	102
9. Precautions	103
10. Revision History	104
Appendix.....	106
List of All pins	106
Part Naming Conventions.....	108
RESTRICTIONS ON PRODUCT USE.....	109

List of Figures

Figure 1.1	Block diagram of the TMPM3H Group(1)	12
Figure 3.1	Example of the TMPM3H6FW	22
Figure 4.1	Capacitors between power supply pins	29
Figure 7.1	1 st clock edge sampling (Master)	77
Figure 7.2	2 nd clock edge sampling (Master)	77
Figure 7.3	2 nd clock edge sampling (Slave)	78
Figure 7.4	AC timing of I ² C	80
Figure 7.5	Count Pulse input	82
Figure 7.6	SWD waveform	84
Figure 7.7	JTAG waveform	85
Figure 7.8	Trace signal waveform	86
Figure 7.9	SCOUT wave output	87
Figure 7.10	External clock input waveform	88
Figure 7.11	Oscillation circuit sample	91

List of Tables

Table 1	Products Lists (1)	2
Table 2	Products Lists (2)	3
Table 3.1	Memory sizes and addresses	23
Table 4.1	Pin names and functions of peripheral pins	24
Table 4.2	Debug pin names and their function	26
Table 4.3	Control pin names and their function	27
Table 4.4	Power supply pin names and their function	28
Table 4.5	SCOUT	30
Table 4.6	INTx	30
Table 4.7	T32A00, T32A01	31
Table 4.8	T32A02, T32A03	32
Table 4.9	T32A04, T32A05	33
Table 4.10	TSPI0, TSPI1	34
Table 4.11	UART0, UART1	35
Table 4.12	UART2	36
Table 4.13	I ² C0, I ² C1, I ² C2	36
Table 4.14	PMD+, A-ENC	37
Table 4.15	AINAx, DACx	38
Table 4.16	TRGINx, RXINx, RTCOUT	38
Table 4.17	Debug pins	39
Table 4.18	Control Pins	39
Table 4.19	Power Supply pins	40
Table 4.20	Port names, and specifications of Port A, B, C, D, E, F	42
Table 4.21	Port names, and specifications of Port G, J, K, L, M	43
Table 4.22	Port names, and specifications of Port N, P, R	44
Table 5.1	Reference Manuals for TMPM3H Group(1)	45
Table 5.2	Core revision	46
Table 5.3	Configurable options and their implementations	46
Table 5.4	Built-in Oscillator	48
Table 5.5	Built-in TRM	48
Table 5.6	Built-in OFD	48
Table 5.7	Built-in LVD	49
Table 5.8	Number of External Interrupt (Built-in DNF)	49
Table 5.9	Built-in Debug Interface	50
Table 5.10	Built-in DMAC	51
Table 5.11	Built-in UART	51
Table 5.12	Built-in TSPI	51
Table 5.13	Built-in I ² C	52

Table 5.14	Built-in DAC.....	52
Table 5.15	Built-in ADC.....	53
Table 5.16	Number of analog inputs for ADC.....	53
Table 5.17	Built-in PMD+	53
Table 5.18	Built-in A-ENC	53
Table 5.19	Built-in T32A.....	54
Table 5.20	Built-in RTC.....	54
Table 5.21	Built-in SIWDT.....	55
Table 5.22	Built-in RMC	55
Table 5.23	Built-in BSC.....	55
Table 7.1	Absolute maximum ratings.....	63
Table 7.2	IDD measurement condition (Pin setting, Oscillation Circuit).....	68
Table 7.3	IDD measurement condition (CPU, Peripheral).....	69
Table 10.1	Revision History	104

Preface

Conventions

- Numeric formats follow the rules as shown below:
 - Hexadecimal: 0xABC
 - Decimal: 123 or 0d123 – Only when it needs to be explicitly shown that they are decimal numbers.
 - Binary: 0b111 – It is possible to omit the "0b" when the number of bit can be distinctly understood from a sentence.
- "_N" is added to the end of signal names to indicate low active signals.
- It is called "assert" that a signal moves to its active level, "deassert" to its inactive level.
- When two or more signal names are referred, they are described like as [m: n].
Example: S[3:0] shows four signal names S3, S2, S1 and S0 together.
- The characters surrounded by [] defines the register.
Example: [ABCD]
- "n" substitutes suffix number of two or more same kind of registers, fields, and bit names.
Example: [XYZ1], [XYZ2], [XYZ3] → [XYZn]
- "x" substitutes suffix number or character of units and channels in the Register List.
 - In case of unit, "x" means A, B, and C . . .
 - Example: [ADACR0], [ADBCR0], [ADCCR0] → [ADxCR0]
 - In case of channel, "x" means 0, 1, and 2 . . .
 - Example: [T32A0RUNA], [T32A1RUNA], [T32A2RUNA] → [T32AxRUNA]
- The bit range of a register is written like as [m: n].
Example: Bit[3: 0] expresses the range of bit 3 to 0.
- The configuration value of a register is expressed by either the hexadecimal number or the binary number.
Example: [ABCD]<EFG> = 0x01 (hexadecimal), [XYZn]<VW> = 1 (binary)
- Word and Byte represent the following bit length.
 - Byte: 8 bits
 - Half word: 16 bits
 - Word: 32 bits
 - Double word: 64 bits
- Properties of each bit in a register are expressed as follows:
 - R: Read only
 - W: Write only
 - R/W: Read and Write are possible
- Unless otherwise specified, register access supports only word access.
- The register defined as reserved must not be rewritten. Moreover, do not use the read value.
- The value read from the bit having default value of "-" is unknown.
- When a register containing both of writable bits and read-only bits is written, read-only bits should be written with their default value, In the cases that default is "-", follow the definition of each register.
- Reserved bits of the Write-only register should be written with their default value. In the cases that default is "-", follow the definition of each register.
- Do not use read-modified-write processing to the register of a definition which is different by writing and read out.

Arm, Cortex and Thumb are registered trademarks of Arm Limited (or its subsidiaries) in the US
and/or elsewhere. All rights reserved.



The Flash memory uses the Super Flash® technology under license from Silicon Storage Technology, Inc.
Super Flash® is registered trademark of Silicon Storage Technology, Inc.

All other company names, product names, and service names mentioned herein may be trademarks of their respective companies.

Terms and Abbreviations

The following words are terms or abbreviations mainly used in this datasheet.

ADC	Analog to Digital Converter
A-ENC	Advanced Encoder Input Circuit
BSC	Boundary Scan
DAC	Digital to Analog Converter
DMAC	Direct Memory Access Controller
DNF	Digital Noise Filter
ELOSC	External Low Speed Oscillator
EHOSC	External High Speed Oscillator
Fm+	I ² C Fast Mode Plus
IHOSC	Internal High Speed Oscillator
INT	Interrupt
I ² C	Inter-Integrated Circuit
I ² CS	I ² C wake-up circuit from Stand-by mode
LVD	Voltage Detection Circuit
NMI	Non-Maskable Interrupt
OFD	Oscillation Frequency Detector
PMD+	Programmable Motor Control Circuit Plus
POR	Power On Reset Circuit
RMC	Remote Control Signal Preprocessor
RTC	Real Time Clock
SIWDT	Clock Selective Watchdog Timer
TRGSEL	Trigger Selection Circuit
TSPI	Toshiba Serial Peripheral Interface
T32A	32-bit Timer Event Counter
UART	Universal Asynchronous Receiver Transmitter

1. Block Diagram

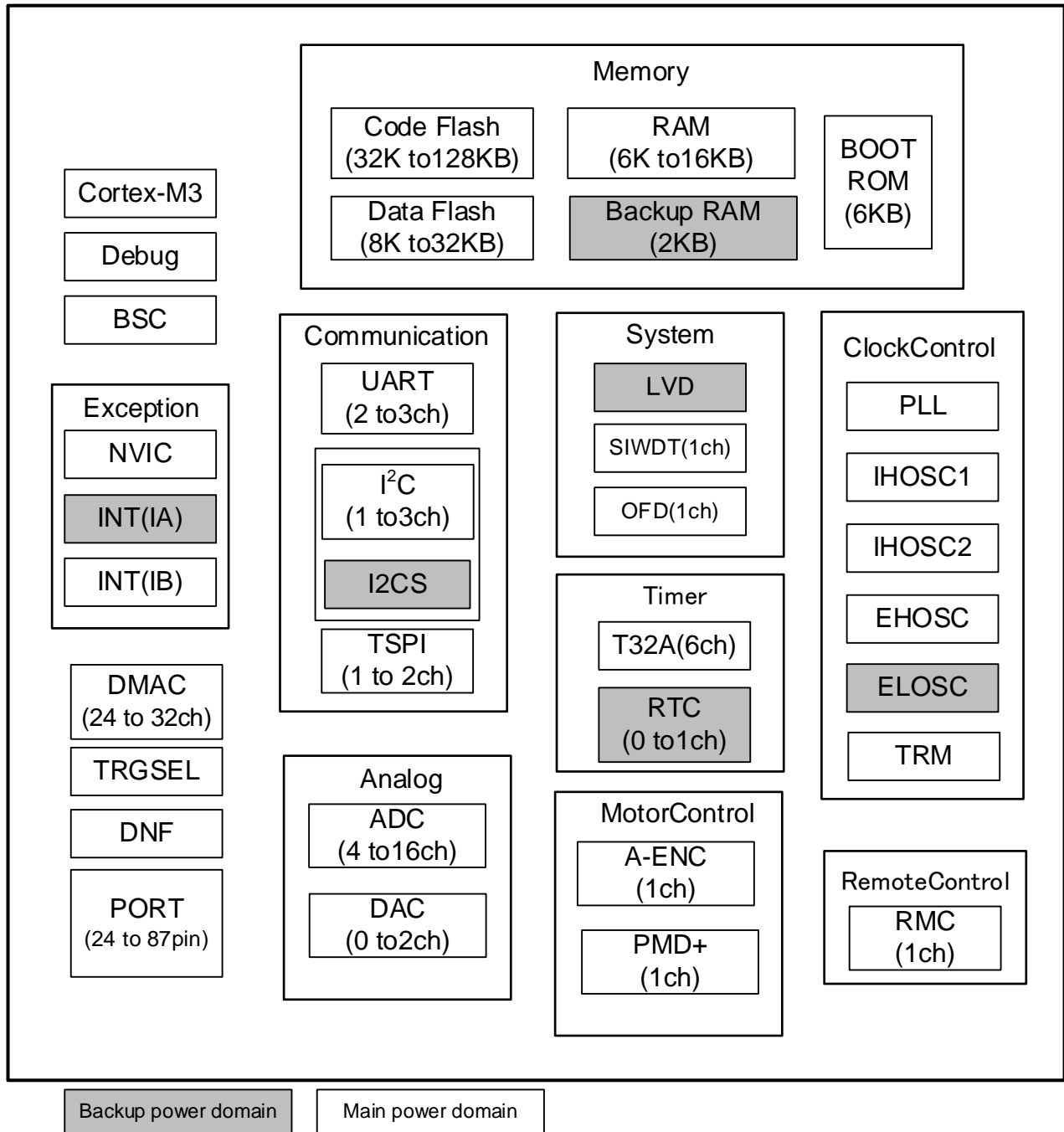
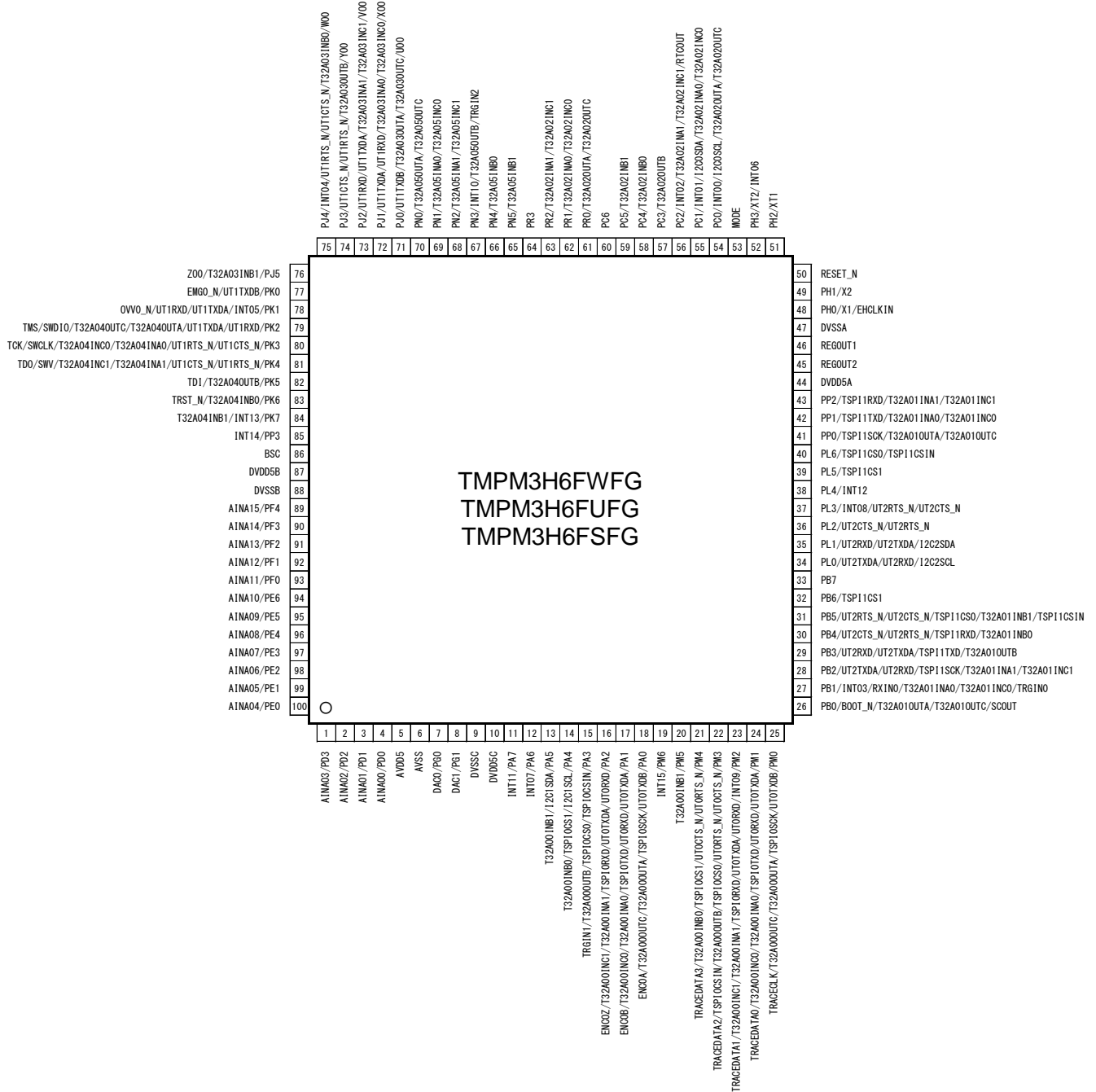

Figure 1.1 Block diagram of the TMPM3H Group(1)

2. Pin Assignment

2.1. LQFP100



2.3. LQFP80

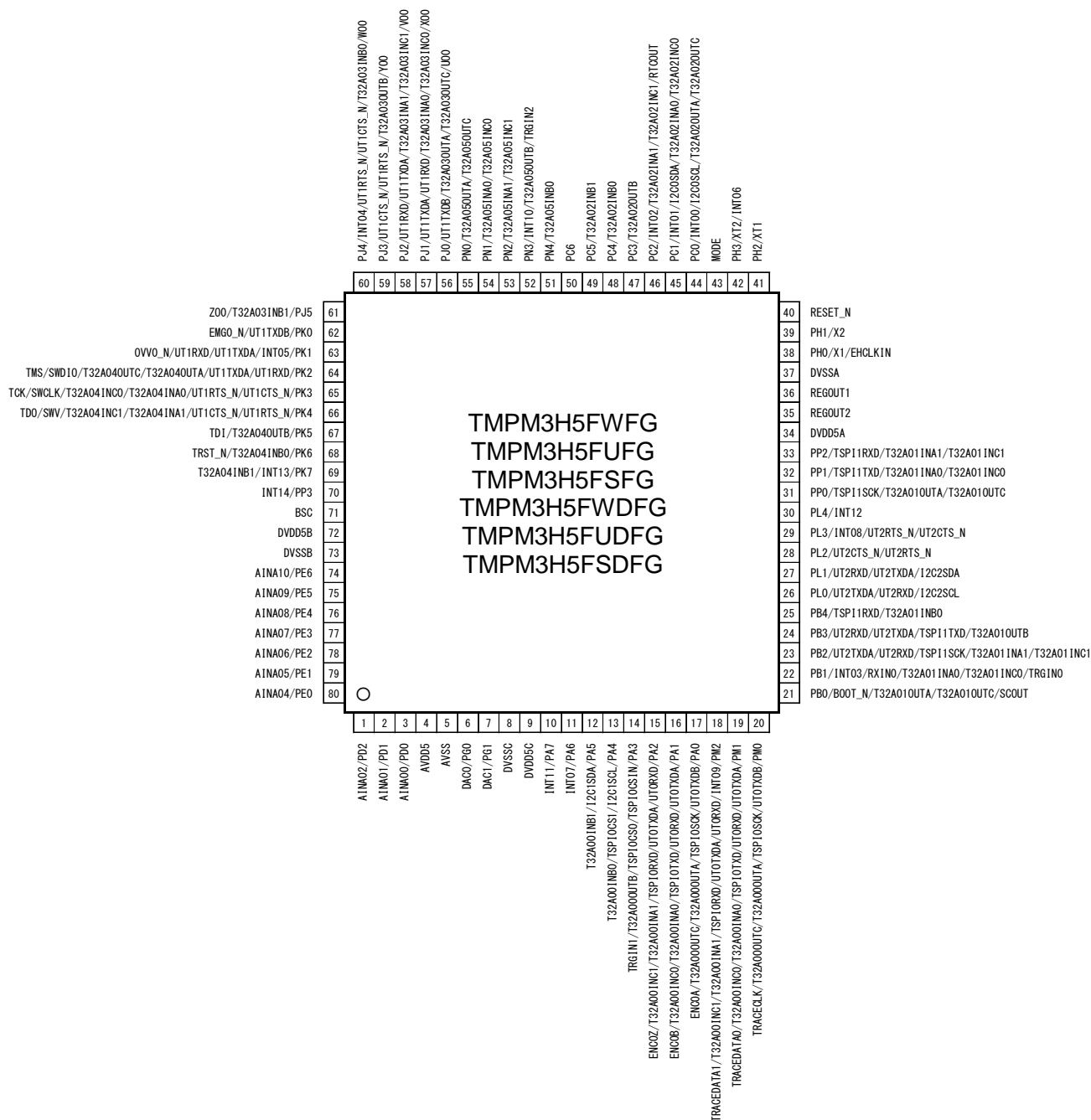

2.4. LQFP64

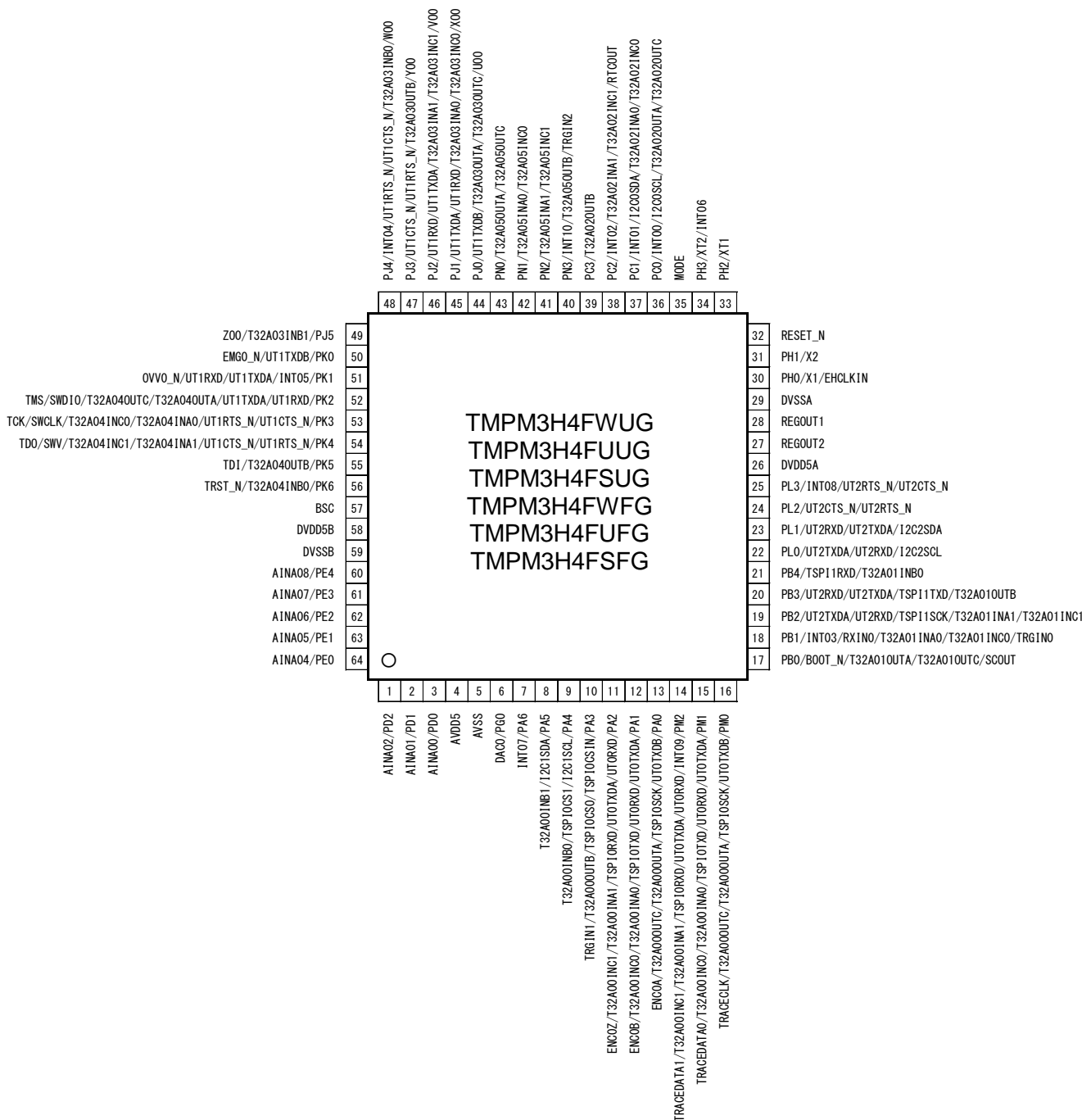

2.5. LQFP52

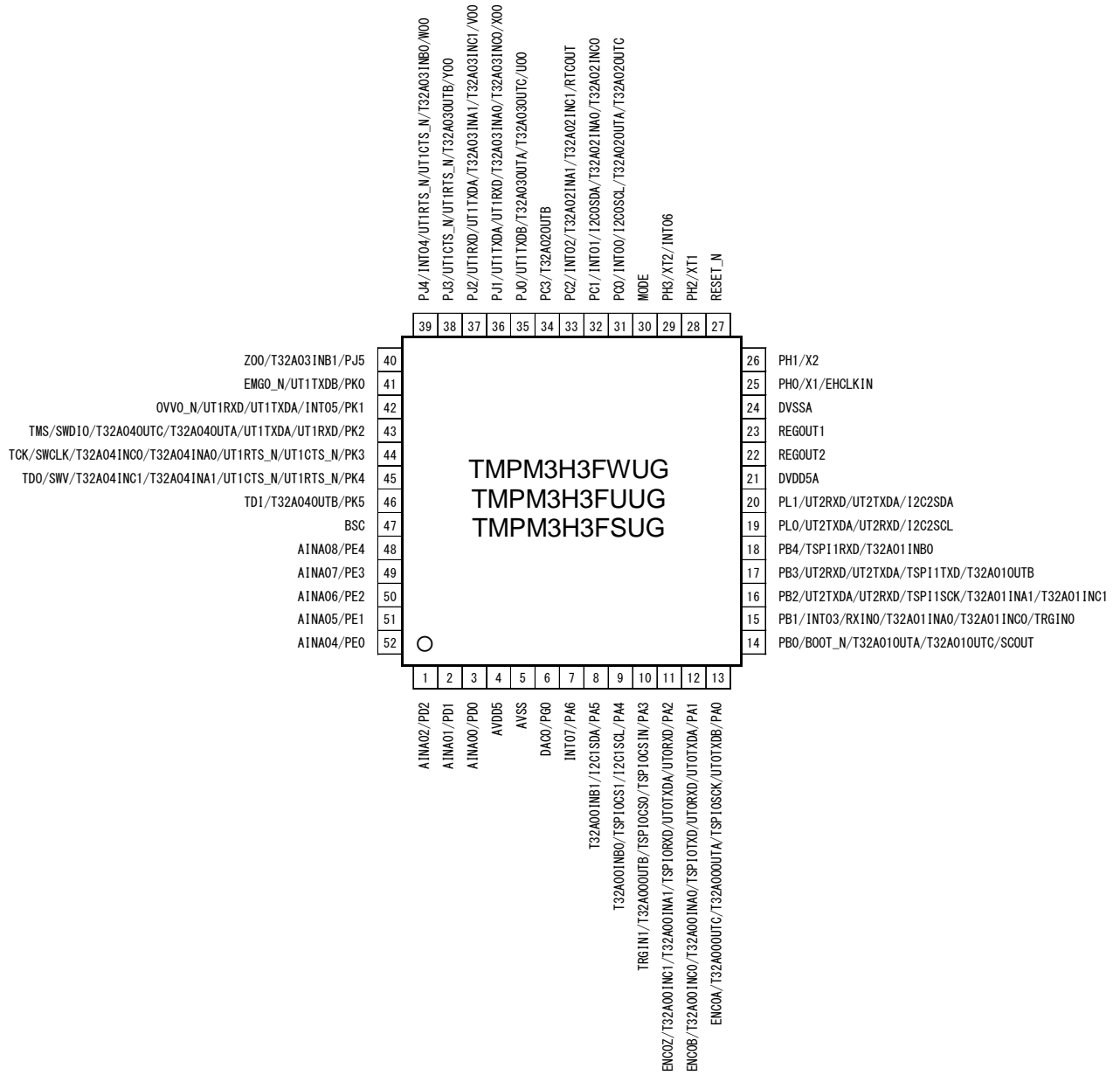

2.6. LQFP48

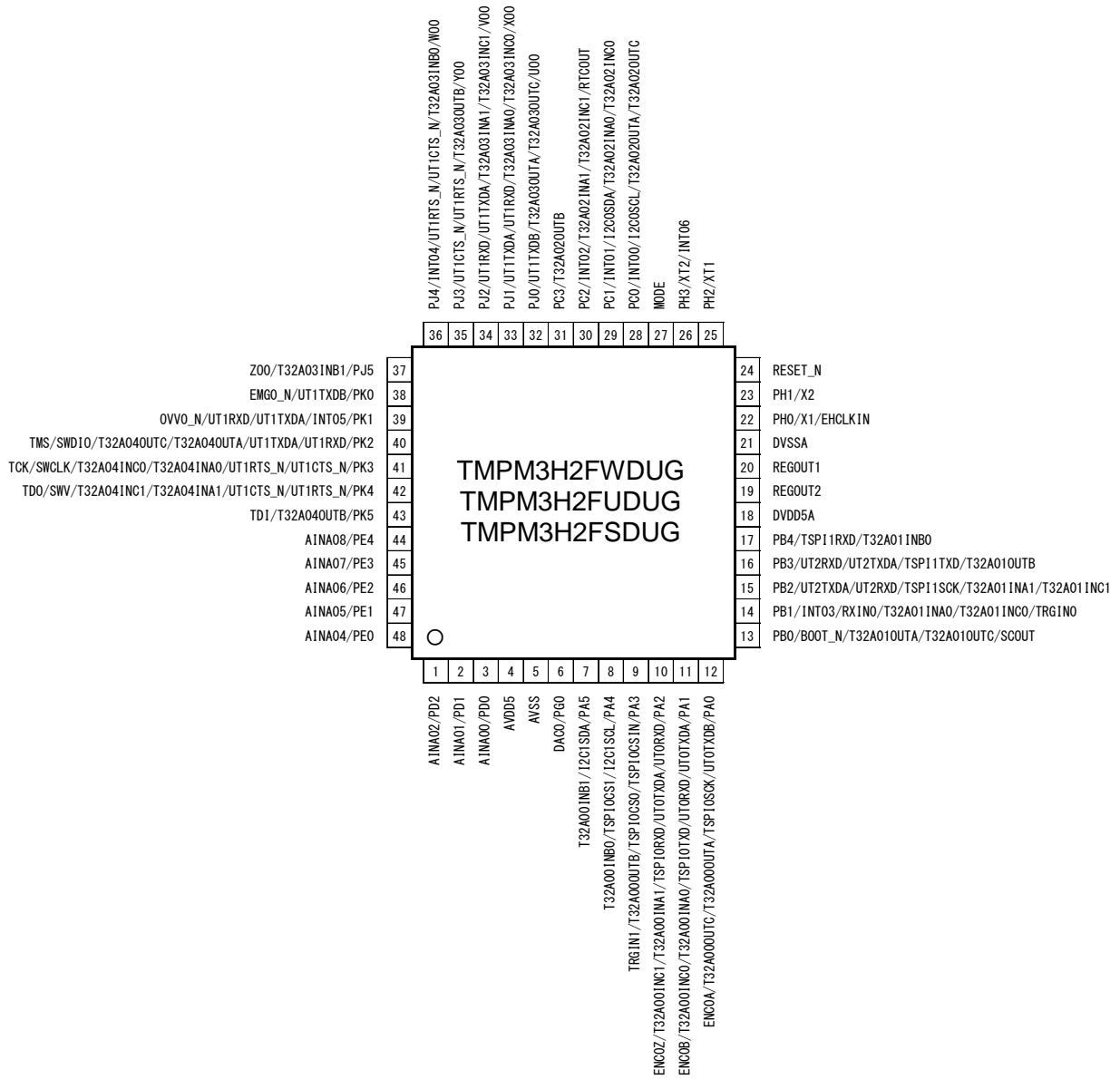

2.7. VQFN48

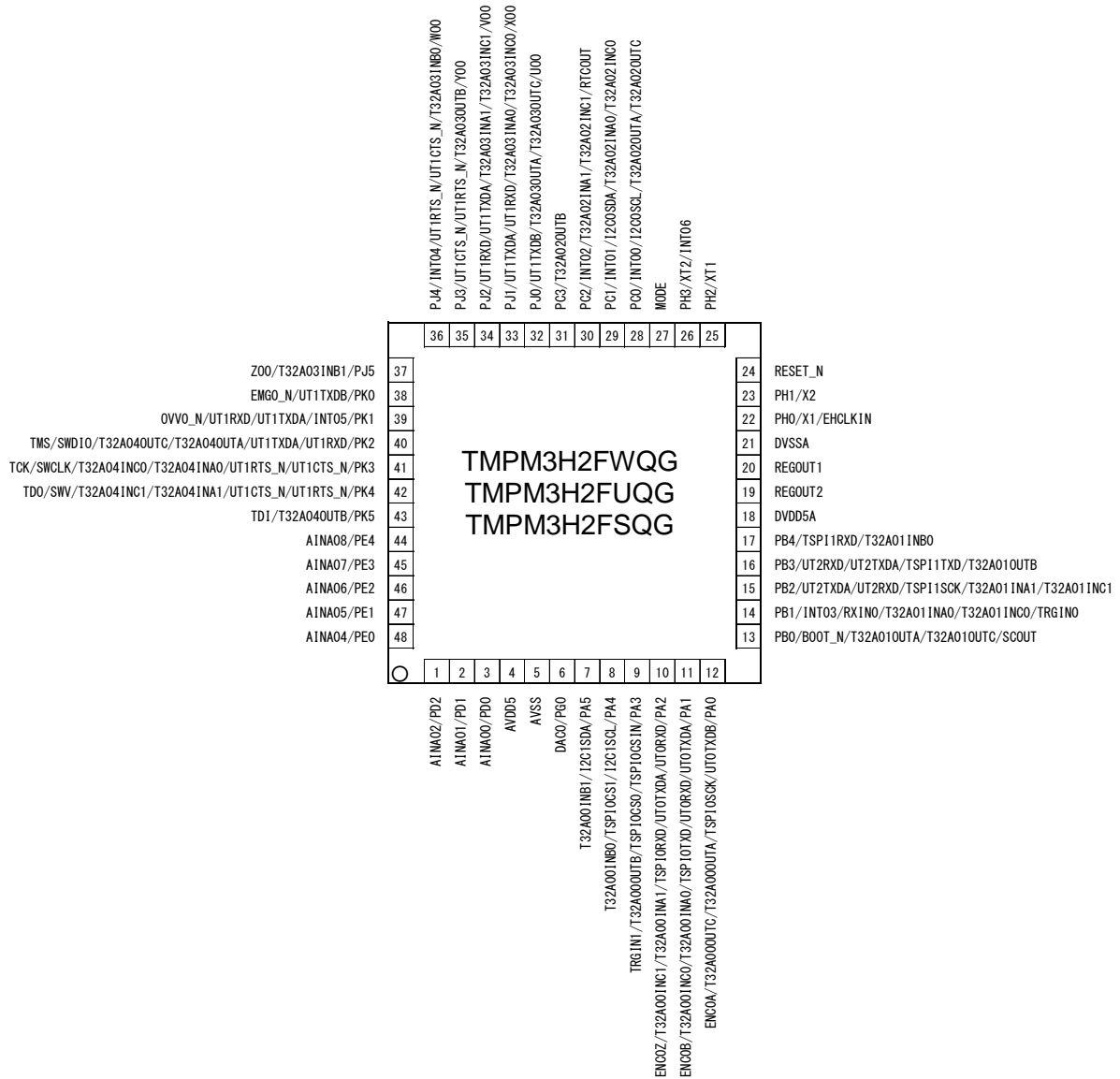

2.8. LQFP44

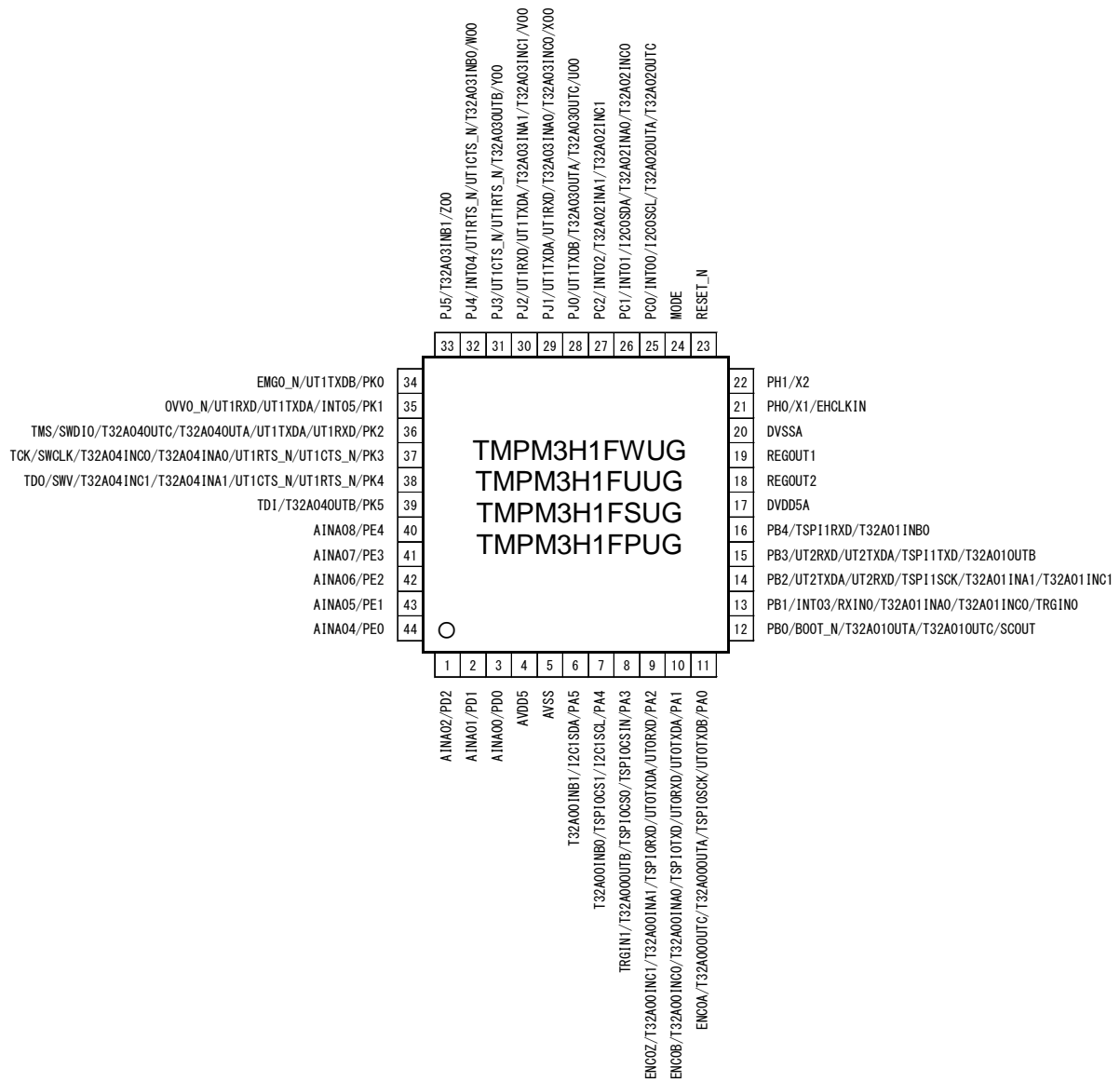

2.9. LQFP32



3. Memory Map

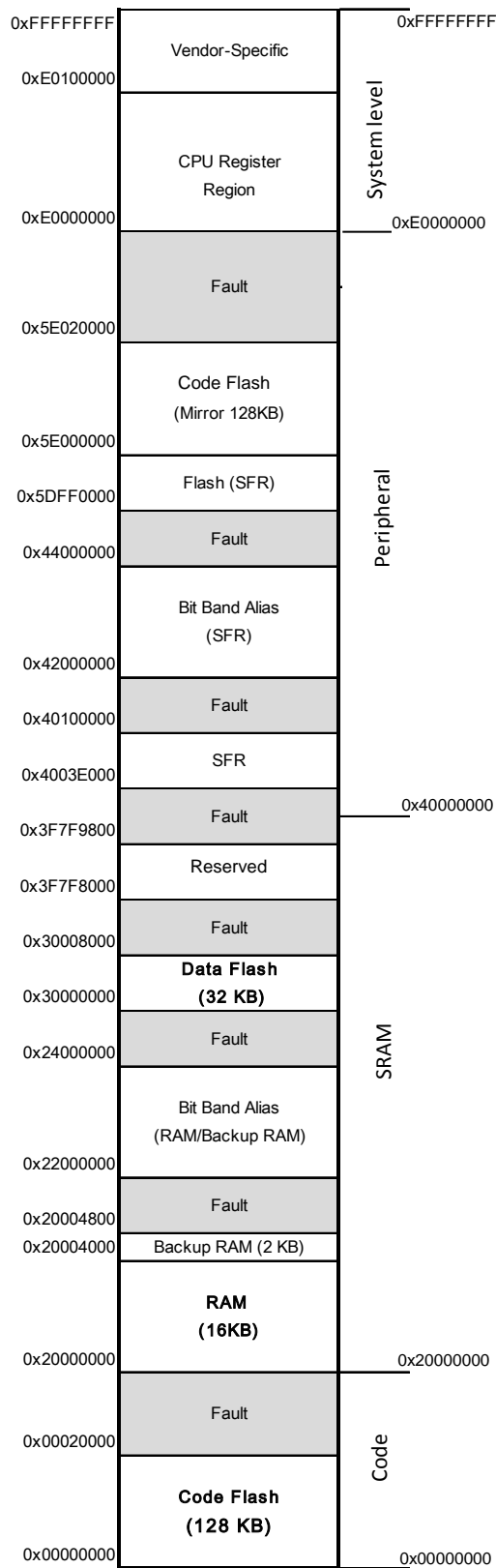

Figure 3.1 Example of the TPM3H6FW

3.1. List of Memory Sizes

Table 3.1 Memory sizes and addresses

Products			TMPM3H6FWFG TMPM3H6FWDFG TMPM3H5FWFG TMPM3H5FWDFG TMPM3H4FWFG TMPM3H4FWUG TMPM3H3FWUG TMPM3H2FWDUG TMPM3H2FWQG TMPM3H1FWUG	TMPM3H6FUFG TMPM3H6FUDFG TMPM3H5FUFG TMPM3H5FUDFG TMPM3H4FUFG TMPM3H4FUUG TMPM3H3FUUG TMPM3H2FUDUG TMPM3H2FUQG TMPM3H1FUUG	TMPM3H6FSFG TMPM3H6FSDFG TMPM3H5FSFG TMPM3H5FSDFG TMPM3H4FSFG TMPM3H4FSUG TMPM3H3FSUG TMPM3H2FSDUG TMPM3H2FSQG TMPM3H1FSUG TMPM3H0FSDUG	TMPM3H1FPUG	TMPM3H0FMDUG
Peripheral region	Code Flash (Mirror)	Size	128KB	96KB	64KB	48KB	32KB
		START	0x5E000000	0x5E000000	0x5E000000	0x5E000000	0x5E000000
		END	0x5E01FFFF	0x5E017FFF	0x5E00FFFF	0x5E00BFFF	0x5E007FFF
SRAM region	Data Flash	Size	32 KB		16 KB	8 KB	
		START	0x30000000		0x30000000	0x30000000	
		END	0x30007FFF		0x30003FFF	0x30001FFF	
	Backup RAM	Size	2 KB				
		START	0x20004000				
		END	0x200047FF				
	RAM	Size	16 KB	12 KB	8 KB	6 KB	6 KB
		START	0x20000000	0x20000000	0x20000000	0x20000000	0x20000000
		END	0x20003FFF	0x20002FFF	0x20001FFF	0x200017FF	0x200017FF
Code Region	Code Flash	Size	128 KB	96 KB	64 KB	48 KB	32 KB
		START	0x00000000	0x00000000	0x00000000	0x00000000	0x00000000
		END	0x0001FFFF	0x00017FFF	0x0000FFFF	0x0000BFFF	0x00007FFF

4. Pin Description

4.1. Functional Pin Name and Their Functions

4.1.1. Peripheral Function Pins

Table 4.1 Pin names and functions of peripheral pins

Peripheral function	Pin name	Input or Output	Function
Clock/Mode control (CG)	SCOUT	Output	Output pin for the system clock
Interrupt control (IA/IB)	INTx	Input	External interrupt input pin External input pin provides the noise filter (filter width: typ. 30 ns).
32-bit Timer event counter (T32A)	T32AxINA0	Input	16-bit timer A input capture input pin 0
	T32AxINA1	Input	16-bit timer A input capture input pin 1
	T32AxOUTA	Output	16-bit timer A output pin
	T32AxINB0	Input	16-bit timer B input capture input pin 0
	T32AxINB1	Input	16-bit timer B input capture input pin 1
	T32AxOUTB	Output	16-bit timer B output pin
	T32AxINC0	Input	32-bit timer input capture input pin 0
	T32AxINC1	Input	32-bit timer input capture input pin 1
	T32AxOUTC	Output	32-bit timer output pin
Serial peripheral interface (TSPI)	TSPIxCSIN	Input	Chip select input pin
	TSPIxCS0	Output	Chip select output pin 0
	TSPIxCS1	Output	Chip select output pin 1
	TSPIxRXD	Input	Data input pin
	TSPIxTXD	Output	Data output pin
	TSPIxSCK	I/O	Clock input/output pin
Asynchronous serial communication circuit (UART)	UTxRXD	Input	Data input
	UTxTXDA	Output	Data output pin A
	UTxTXDB	Output	Data output pin B
	UTxCTS_N	Input	Clear to send signal pin
	UTxRTS_N	Output	Request to send signal pin
I ² C interface (I ² C)	I2CxSDA	I/O	Data input/output pin
	I2CxSCL	I/O	Clock input/output pin

Motor control circuit (PMD+)	EMGx_N	Input	Emergency state detection input pin
	OVVx_N	Input	Over voltage detection input
	UOx	Output	U-phase output pin
	VOx	Output	V-phase output pin
	WOx	Output	W-phase output pin
	XOx	Output	X-phase output pin
	YOx	Output	Y-phase output pin
	ZOx	Output	Z-phase output pin
Encoder input circuit (A-ENC)	ENCxA	Input	Encoder input
	ENCxB	Input	Encoder input
	ENCxZ	Input	Encoder input
Analog-to-digital converter (ADC)	AINAx	Input	Analog input pin
Digital-to- analog converter (DAC)	DACx	Output	DAC output pin
Trigger input	TRGINx	Input	External trigger input pin
Remote signaling receive circuit (RMC)	RXINx	Input	Remote Signaling Data input pin
Real time clock (RTC)	RTCOUT	Output	1Hz clock output pin

Note: "x" means channel number or unit number or interrupt number.

4.1.2. Debug Pins

Table 4.2 Debug pin names and their function

Debug Port	Pin name	Input or Output	Function
JTAG	TMS	Input	JTAG test mode selection input pin
	TCK	Input	JTAG serial clock input pin
	TDO	Output	JTAG serial data output pin
	TDI	Input	JTAG serial data input pin
	TRST_N	Input	JTAG test reset input pin
SW	SWDIO	I/O	Serial wire data input/output pin
	SWCLK	Input	Serial wire clock input pin
	SWV	Output	Serial wire viewer output pin
TRACE	TRACECLK	Output	Trace clock output pin
	TRACEDATA0	Output	Trace data output pin 0
	TRACEDATA1	Output	Trace data output pin 1
	TRACEDATA2	Output	Trace data output pin 2
	TRACEDATA3	Output	Trace data output pin 3

4.1.3. Control Pins

Table 4.3 Control pin names and their function

	Pin name	Input or Output	Function
Control Pin	X1	Input	High-speed oscillator connection pin
	X2	Output	High-speed oscillator connection pin
	XT1	Input	Low-speed oscillator connection pin
	XT2	Output	Low-speed oscillator connection pin
	EHCLKIN	Input	External Clock signal input pin
	BOOT_N	Input	BOOT mode control pin The BOOT mode control pin is sampled on the rising edge of the RESET_N input. It's not sampled by internal Reset factor. If the BOOT mode control pin is "Low" level, the MCU enters single boot mode. If it is "High", the MCU enters single chip mode. For details, refer to "Flash Memory" reference manual.
	RESET_N	Input	Reset signal input pin
	MODE	Input	Mode pin This pin must be fixed to the "Low" level.
	BSC	Input	Boundary scan mode control pin

4.1.4. Power Supply Pins

Table 4.4 Power supply pin names and their function

Function	Pin name	Function
Power Supply	DVDD5A (Note1) DVDD5B (Note1) DVDD5C (Note1)	Power supply pin for digital DVDD5A/B/C supplies the power to the following pins: PA to PC, PH to PR, MODE, RESET_N, BOOT_N, BSC A power supply is supplied to an oscillating circuit from a built-in regulator. X1,X2,XT1,XT2
	DVSSA (Note2) DVSSB (Note2) DVSSC (Note2)	GND pin for digital
	REGOUT1 (Note3)	Capacitor for a regulator connection pin (Note4)
	REGOUT2 (Note3)	Capacitor for a regulator connection pin (Note4)
	AVDD5	Power supply pin and reference power pin (VREFH) for analog are combination pins. AVDD5 supplies the power to the following pins: PD, PE, PF, PG
	AVSS	GND pin for analog, reference GND (VREFL) for analog are combination pins.

Note1: Apply the voltage to DVDD5A, DVDD5B, and DVDD5C at the same potential except the case that the pins are not provided.

Note2: Apply the external voltage to DVSSA, DVSSB, and DVSSC at the same potential except the case that the pins are not provided.

Note3: For REGOUT1 and REGOUT2, do not cause a short circuit with DVDD5A, DVDD5B, or DVDD5C; or DVSSA, DVSSB, or DVSSC.

Note4: For the capacitor value, refer to the "Electrical Characteristics"

4.1.5. Capacitors between power supply pins

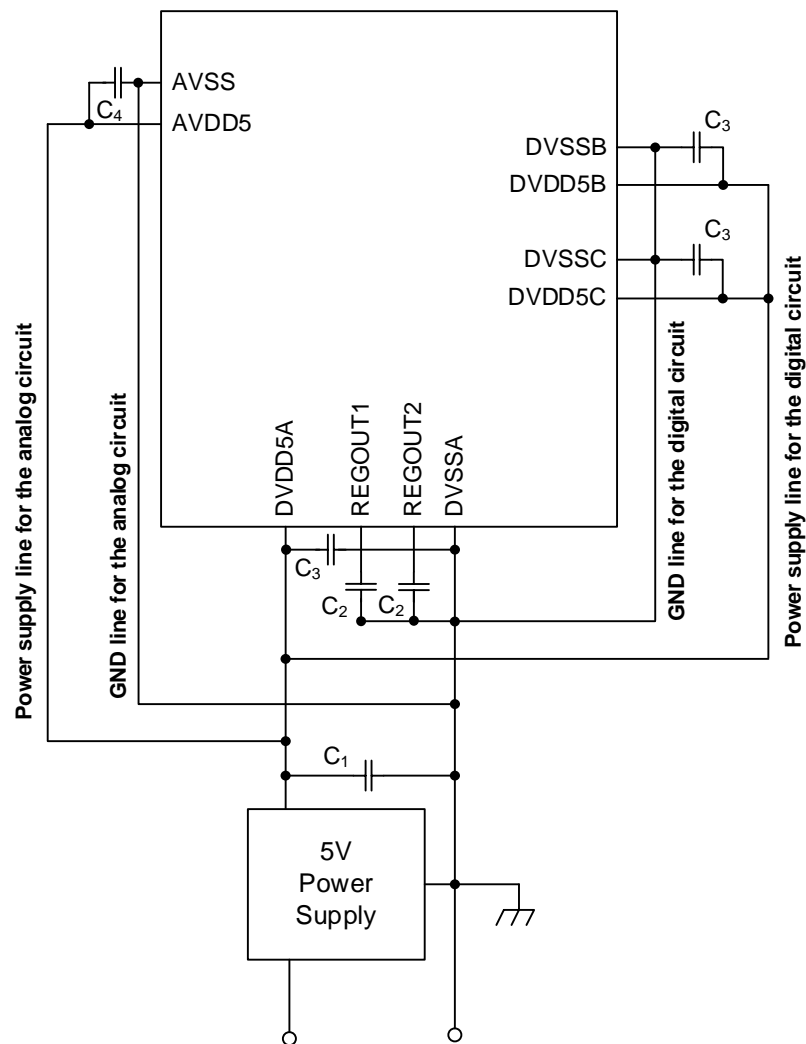

Figure 4.1 Capacitors between power supply pins

Note1: 5V power supply output capacitor (C₁: min 1 μF) must be placed on the shortest distance from the output pin of 5V power supply. Ceramic capacitor recommended for C₁.

Note2: Bypass capacitor must be placed between the 5V power supply and GND near each MCU power supply pin.(C₃,C₄:0.01 to 0.1μF)

Note3: Power stabilizing Capacitors of REGOUT1 and REGOUT2 for built-in regulators must be the same capacity(C₂:4.7μF), and ceramic capacitor recommended for C₂. They must be placed on the shortest distance from DVSSA.

Note4: Separate the analog power supply line and the digital power supply line near the 5V power supply output pin in order to reduce noise mixing into the analog circuit from the digital power supply.

Note5: When inserting a filter circuit or pull-up / down resistor at the input / output pin of the analog power supply system to reduce noise mixing from the peripheral circuit to the analog circuit, connect the components that make up these circuits to the analog power supply line.

Note6: Do not separate the power supply line and the GND line from each other in order to reduce high frequency noise etc, received by the power supply line, the GND line, and the loop circuit of the capacitor.

4.2. Functional Pin and Ports Assignment (Pin Number)

Following table shows a pin number of the port assignment and each product which were seen from the functional pin.

"-" means that it does not have a pin or there is no assignment of a function.

Table 4.5 SCOUT

Combination functional pin name	Port Name	M3H6 (LQFP100)	M3H6 (QFP100)	M3H5 (LQFP80)	M3H4 (LQFP64)	M3H3 (LQFP52)	M3H2 (LQFP48) (VQFN48)	M3H1 (LQFP44)	M3H0 (LQFP32)
SCOUT	PB0	26	28	21	17	14	13	12	8

Table 4.6 INTx

Combination functional pin name	Port Name	M3H6 (LQFP100)	M3H6 (QFP100)	M3H5 (LQFP80)	M3H4 (LQFP64)	M3H3 (LQFP52)	M3H2 (LQFP48) (VQFN48)	M3H1 (LQFP44)	M3H0 (LQFP32)
INT00	PC0	54	56	44	36	31	28	25	18
INT01	PC1	55	57	45	37	32	29	26	19
INT02	PC2	56	58	46	38	33	30	27	20
INT03	PB1	27	29	22	18	15	14	13	9
INT04	PJ4	75	77	60	48	39	36	32	25
INT05	PK1	78	80	63	51	42	39	35	28
INT06	PH3	52	54	42	34	29	26	-	-
INT07	PA6	12	14	11	7	7	-	-	-
INT08	PL3	37	39	29	25	-	-	-	-
INT09	PM2	23	25	18	14	-	-	-	-
INT10	PN3	67	69	52	40	-	-	-	-
INT11	PA7	11	13	10	-	-	-	-	-
INT12	PL4	38	40	30	-	-	-	-	-
INT13	PK7	84	86	69	-	-	-	-	-
INT14	PP3	85	87	70	-	-	-	-	-
INT15	PM6	19	21	-	-	-	-	-	-

Table 4.7 T32A00, T32A01

Combination functional pin name	Port Name	M3H6 (LQFP100)	M3H6 (QFP100)	M3H5 (LQFP80)	M3H4 (LQFP64)	M3H3 (LQFP52)	M3H2 (LQFP48) (VQFN48)	M3H1 (LQFP44)	M3H0 (LQFP32)
T32A00INA0	PA1	17	19	16	12	12	11	10	6
	PM1	24	26	19	15	-	-	-	-
T32A00INA1	PA2	16	18	15	11	11	10	9	5
	PM2	23	25	18	14	-	-	-	-
T32A00OUTA	PA0	18	20	17	13	13	12	11	7
	PM0	25	27	20	16	-	-	-	-
T32A00INB0	PA4	14	16	13	9	9	8	7	-
	PM4	21	23	-	-	-	-	-	-
T32A00INB1	PA5	13	15	12	8	8	7	6	-
	PM5	20	22	-	-	-	-	-	-
T32A00OUTB	PA3	15	17	14	10	10	9	8	-
	PM3	22	24	-	-	-	-	-	-
T32A00INC0	PA1	17	19	16	12	12	11	10	6
	PM1	24	26	19	15	-	-	-	-
T32A00INC1	PA2	16	18	15	11	11	10	9	5
	PM2	23	25	18	14	-	-	-	-
T32A00OUTC	PA0	18	20	17	13	13	12	11	7
	PM0	25	27	20	16	-	-	-	-
Combination functional pin name	Port Name	M3H6 (LQFP100)	M3H6 (QFP100)	M3H5 (LQFP80)	M3H4 (LQFP64)	M3H3 (LQFP52)	M3H2 (LQFP48) (VQFN48)	M3H1 (LQFP44)	M3H0 (LQFP32)
T32A01INA0	PB1	27	29	22	18	15	14	13	9
	PP1	42	44	32	-	-	-	-	-
T32A01INA1	PB2	28	30	23	19	16	15	14	-
	PP2	43	45	33	-	-	-	-	-
T32A01OUTA	PB0	26	28	21	17	14	13	12	8
	PP0	41	43	31	-	-	-	-	-
T32A01INB0	PB4	30	32	25	21	18	17	16	-
T32A01INB1	PB5	31	33	-	-	-	-	-	-
T32A01OUTB	PB3	29	31	24	20	17	16	15	-
T32A01INC0	PB1	27	29	22	18	15	14	13	9
	PP1	42	44	32	-	-	-	-	-
T32A01INC1	PB2	28	30	23	19	16	15	14	-
	PP2	43	45	33	-	-	-	-	-
T32A01OUTC	PB0	26	28	21	17	14	13	12	8
	PP0	41	43	31	-	-	-	-	-

Table 4.8 T32A02, T32A03

Combination functional pin name	Port Name	M3H6 (LQFP100)	M3H6 (QFP100)	M3H5 (LQFP80)	M3H4 (LQFP64)	M3H3 (LQFP52)	M3H2 (LQFP48) (VQFN48)	M3H1 (LQFP44)	M3H0 (LQFP32)
T32A02INA0	PC1	55	57	45	37	32	29	26	19
	PR1	62	64	-	-	-	-	-	-
T32A02INA1	PC2	56	58	46	38	33	30	27	20
	PR2	63	65	-	-	-	-	-	-
T32A02OUTA	PC0	54	56	44	36	31	28	25	18
	PR0	61	63	-	-	-	-	-	-
T32A02INB0	PC4	58	60	48	-	-	-	-	-
T32A02INB1	PC5	59	61	49	-	-	-	-	-
T32A02OUTB	PC3	57	59	47	39	34	31	-	-
T32A02INC0	PC1	55	57	45	37	32	29	26	19
	PR1	62	64	-	-	-	-	-	-
T32A02INC1	PC2	56	58	46	38	33	30	27	20
	PR2	63	65	-	-	-	-	-	-
T32A02OUTC	PC0	54	56	44	36	31	28	25	18
	PR0	61	63	-	-	-	-	-	-
Combination functional pin name	Port Name	M3H6 (LQFP100)	M3H6 (QFP100)	M3H5 (LQFP80)	M3H4 (LQFP64)	M3H3 (LQFP52)	M3H2 (LQFP48) (VQFN48)	M3H1 (LQFP44)	M3H0 (LQFP32)
T32A03INA0	PJ1	72	74	57	45	36	33	29	22
T32A03INA1	PJ2	73	75	58	46	37	34	30	23
T32A03OUTA	PJ0	71	73	56	44	35	32	28	21
T32A03INB0	PJ4	75	77	60	48	39	36	32	25
T32A03INB1	PJ5	76	78	61	49	40	37	33	26
T32A03OUTB	PJ3	74	76	59	47	38	35	31	24
T32A03INC0	PJ1	72	74	57	45	36	33	29	22
T32A03INC1	PJ2	73	75	58	46	37	34	30	23
T32A03OUTC	PJ0	71	73	56	44	35	32	28	21

Table 4.9 T32A04, T32A05

Combination functional pin name	Port Name	M3H6 (LQFP100)	M3H6 (QFP100)	M3H5 (LQFP80)	M3H4 (LQFP64)	M3H3 (LQFP52)	M3H2 (LQFP48) (VQFN48)	M3H1 (LQFP44)	M3H0 (LQFP32)
T32A04INA0	PK3	80	82	65	53	44	41	37	30
T32A04INA1	PK4	81	83	66	54	45	42	38	-
T32A04OUTA	PK2	79	81	64	52	43	40	36	29
T32A04INB0	PK6	83	85	68	56	-	-	-	-
T32A04INB1	PK7	84	86	69	-	-	-	-	-
T32A04OUTB	PK5	82	84	67	55	46	43	39	-
T32A04INC0	PK3	80	82	65	53	44	41	37	30
T32A04INC1	PK4	81	83	66	54	45	42	38	-
T32A04OUTC	PK2	79	81	64	52	43	40	36	29
Combination functional pin name	Port Name	M3H6 (LQFP100)	M3H6 (QFP100)	M3H5 (LQFP80)	M3H4 (LQFP64)	M3H3 (LQFP52)	M3H2 (LQFP48) (VQFN48)	M3H1 (LQFP44)	M3H0 (LQFP32)
T32A05INA0	PN1	69	71	54	42	-	-	-	-
T32A05INA1	PN2	68	70	53	41	-	-	-	-
T32A05OUTA	PN0	70	72	55	43	-	-	-	-
T32A05INB0	PN4	66	68	51	-	-	-	-	-
T32A05INB1	PN5	65	67	-	-	-	-	-	-
T32A05OUTB	PN3	67	69	52	40	-	-	-	-
T32A05INC0	PN1	69	71	54	42	-	-	-	-
T32A05INC1	PN2	68	70	53	41	-	-	-	-
T32A05OUTC	PN0	70	72	55	43	-	-	-	-

Table 4.10 TSPI0, TSPI1

Combination functional pin name	Port Name	M3H6 (LQFP100)	M3H6 (QFP100)	M3H5 (LQFP80)	M3H4 (LQFP64)	M3H3 (LQFP52)	M3H2 (LQFP48) (VQFN48)	M3H1 (LQFP44)	M3H0 (LQFP32)
TSPI0CSIN	PM3	22	24	-	-	-	-	-	-
	PA3	15	17	14	10	10	9	8	-
TSPI0CS0	PM3	22	24	-	-	-	-	-	-
	PA3	15	17	14	10	10	9	8	-
TSPI0CS1	PM4	21	23	-	-	-	-	-	-
	PA4	14	16	13	9	9	8	7	-
TSPI0RXD	PM2	23	25	18	14	-	-	-	-
	PA2	16	18	15	11	11	10	9	5
TSPI0TXD	PM1	24	26	19	15	-	-	-	-
	PA1	17	19	16	12	12	11	10	6
TSPI0SCK	PM0	25	27	20	16	-	-	-	-
	PA0	18	20	17	13	13	12	11	7
Combination functional pin name	Port Name	M3H6 (LQFP100)	M3H6 (QFP100)	M3H5 (LQFP80)	M3H4 (LQFP64)	M3H3 (LQFP52)	M3H2 (LQFP48) (VQFN48)	M3H1 (LQFP44)	M3H0 (LQFP32)
TSPI1CSIN	PL6	40	42	-	-	-	-	-	-
	PB5	31	33	-	-	-	-	-	-
TSPI1CS0	PL6	40	42	-	-	-	-	-	-
	PB5	31	33	-	-	-	-	-	-
TSPI1CS1	PL5	39	41	-	-	-	-	-	-
	PB6	32	34	-	-	-	-	-	-
TSPI1RXD	PP2	43	45	33	-	-	-	-	-
	PB4	30	32	25	21	18	17	16	-
TSPI1TXD	PP1	42	44	32	-	-	-	-	-
	PB3	29	31	24	20	17	16	15	-
TSPI1SCK	PP0	41	43	31	-	-	-	-	-
	PB2	28	30	23	19	16	15	14	-

Table 4.11 UART0, UART1

Combination functional pin name	Port Name	M3H6 (LQFP100)	M3H6 (QFP100)	M3H5 (LQFP80)	M3H4 (LQFP64)	M3H3 (LQFP52)	M3H2 (LQFP48) (VQFN48)	M3H1 (LQFP44)	M3H0 (LQFP32)
UT0RXD	PA2	16	18	15	11	11	10	9	5
	PA1	17	19	16	12	12	11	10	6
	PM2	23	25	18	14	-	-	-	-
	PM1	24	26	19	15	-	-	-	-
UT0TXDA	PA1	17	19	16	12	12	11	10	6
	PA2	16	18	15	11	11	10	9	5
	PM1	24	26	19	15	-	-	-	-
	PM2	23	25	18	14	-	-	-	-
UT0TXDB	PA0	18	20	17	13	13	12	11	7
	PM0	25	27	20	16	-	-	-	-
UT0CTS_N	PM3	22	24	-	-	-	-	-	-
	PM4	21	23	-	-	-	-	-	-
UT0RTS_N	PM4	21	23	-	-	-	-	-	-
	PM3	22	24	-	-	-	-	-	-
Combination functional pin name	Port Name	M3H6 (LQFP100)	M3H6 (QFP100)	M3H5 (LQFP80)	M3H4 (LQFP64)	M3H3 (LQFP52)	M3H2 (LQFP48) (VQFN48)	M3H1 (LQFP44)	M3H0 (LQFP32)
UT1RXD	PJ2	73	75	58	46	37	34	30	23
	PJ1	72	74	57	45	36	33	29	22
	PK2	79	81	64	52	43	40	36	29
	PK1	78	80	63	51	42	39	35	28
UT1TXDA	PJ1	72	74	57	45	36	33	29	22
	PJ2	73	75	58	46	37	34	30	23
	PK1	78	80	63	51	42	39	35	28
	PK2	79	81	64	52	43	40	36	29
UT1TXDB	PJ0	71	73	56	44	35	32	28	21
	PK0	77	79	62	50	41	38	34	27
UT1CTS_N	PJ3	74	76	59	47	38	35	31	24
	PJ4	75	77	60	48	39	36	32	25
	PK3	80	82	65	53	44	41	37	-
	PK4	81	83	66	54	45	42	38	-
UT1RTS_N	PJ4	75	77	60	48	39	36	32	25
	PJ3	74	76	59	47	38	35	31	24
	PK4	81	83	66	54	45	42	38	-
	PK3	80	82	65	53	44	41	37	-

Table 4.12 UART2

Combination functional pin name	Port Name	M3H6 (LQFP100)	M3H6 (QFP100)	M3H5 (LQFP80)	M3H4 (LQFP64)	M3H3 (LQFP52)	M3H2 (LQFP48) (VQFN48)	M3H1 (LQFP44)	M3H0 (LQFP32)
UT2RXD	PB3	29	31	24	20	17	16	15	-
	PB2	28	30	23	19	16	15	14	-
	PL1	35	37	27	23	20	-	-	-
	PL0	34	36	26	22	19	-	-	-
UT2TXDA	PB2	28	30	23	19	16	15	14	-
	PB3	29	31	24	20	17	16	15	-
	PL0	34	36	26	22	19	-	-	-
	PL1	35	37	27	23	20	-	-	-
UT2CTS_N	PB4	30	32	-	-	-	-	-	-
	PB5	31	33	-	-	-	-	-	-
	PL2	36	38	28	24	-	-	-	-
	PL3	37	39	29	25	-	-	-	-
UT2RTS_N	PB5	31	33	-	-	-	-	-	-
	PB4	30	32	-	-	-	-	-	-
	PL3	37	39	29	25	-	-	-	-
	PL2	36	38	28	24	-	-	-	-

Table 4.13 I²C0, I²C1, I²C2

Combination functional pin name	Port Name	M3H6 (LQFP100)	M3H6 (QFP100)	M3H5 (LQFP80)	M3H4 (LQFP64)	M3H3 (LQFP52)	M3H2 (LQFP48) (VQFN48)	M3H1 (LQFP44)	M3H0 (LQFP32)
I2C0SDA	PC1	55	57	45	37	32	29	26	19
I2C0SCL	PC0	54	56	44	36	31	28	25	18
I2C1SDA	PA5	13	15	12	8	8	7	6	-
I2C1SCL	PA4	14	16	13	9	9	8	7	-
I2C2SDA	PL1	35	37	27	23	20	-	-	-
I2C2SCL	PL0	34	36	26	22	19	-	-	-

Table 4.14 PMD+, A-ENC

Combination functional pin name	Port Name	M3H6 (LQFP100)	M3H6 (QFP100)	M3H5 (LQFP80)	M3H4 (LQFP64)	M3H3 (LQFP52)	M3H2 (LQFP48) (VQFN48)	M3H1 (LQFP44)	M3H0 (LQFP32)
EMG0_N	PK0	77	79	62	50	41	38	34	27
OVV0_N	PK1	78	80	63	51	42	39	35	28
UO0	PJ0	71	73	56	44	35	32	28	21
VO0	PJ2	73	75	58	46	37	34	30	23
WO0	PJ4	75	77	60	48	39	36	32	25
XO0	PJ1	72	74	57	45	36	33	29	22
YO0	PJ3	74	76	59	47	38	35	31	24
ZO0	PJ5	76	78	61	49	40	37	33	26
Combination functional pin name	Port Name	M3H6 (LQFP100)	M3H6 (QFP100)	M3H5 (LQFP80)	M3H4 (LQFP64)	M3H3 (LQFP52)	M3H2 (LQFP48) (VQFN48)	M3H1 (LQFP44)	M3H0 (LQFP32)
ENC0A	PA0	18	20	17	13	13	12	11	7
ENC0B	PA1	17	19	16	12	12	11	10	6
ENC0Z	PA2	16	18	15	11	11	10	9	5

Table 4.15 AINAx, DACx

Combination functional pin name	Port Name	M3H6 (LQFP100)	M3H6 (QFP100)	M3H5 (LQFP80)	M3H4 (LQFP64)	M3H3 (LQFP52)	M3H2 (LQFP48) (VQFN48)	M3H1 (LQFP44)	M3H0 (LQFP32)
AINA00	PD0	4	6	3	3	3	3	3	2
AINA01	PD1	3	5	2	2	2	2	2	1
AINA02	PD2	2	4	1	1	1	1	1	-
AINA03	PD3	1	3	-	-	-	-	-	-
AINA04	PE0	100	2	80	64	52	48	44	32
AINA05	PE1	99	1	79	63	51	47	43	31
AINA06	PE2	98	100	78	62	50	46	42	-
AINA07	PE3	97	99	77	61	49	45	41	-
AINA08	PE4	96	98	76	60	48	44	40	-
AINA09	PE5	95	97	75	-	-	-	-	-
AINA10	PE6	94	96	74	-	-	-	-	-
AINA11	PF0	93	95	-	-	-	-	-	-
AINA12	PF1	92	94	-	-	-	-	-	-
AINA13	PF2	91	93	-	-	-	-	-	-
AINA14	PF3	90	92	-	-	-	-	-	-
AINA15	PF4	89	91	-	-	-	-	-	-
Combination functional pin name	Port Name	M3H6 (LQFP100)	M3H6 (QFP100)	M3H5 (LQFP80)	M3H4 (LQFP64)	M3H3 (LQFP52)	M3H2 (LQFP48) (VQFN48)	M3H1 (LQFP44)	M3H0 (LQFP32)
DAC0	PG0	7	9	6	6	6	6	-	-
DAC1	PG1	8	10	7	-	-	-	-	-

Table 4.16 TRGINx, RXINx, RTCOUT

Combination functional pin name	Port Name	M3H6 (LQFP100)	M3H6 (QFP100)	M3H5 (LQFP80)	M3H4 (LQFP64)	M3H3 (LQFP52)	M3H2 (LQFP48) (VQFN48)	M3H1 (LQFP44)	M3H0 (LQFP32)
TRGIN0	PB1	27	29	22	18	15	14	13	9
TRGIN1	PA3	15	17	14	10	10	9	8	-
TRGIN2	PN3	67	69	52	40	-	-	-	-
Combination functional pin name	Port Name	M3H6 (LQFP100)	M3H6 (QFP100)	M3H5 (LQFP80)	M3H4 (LQFP64)	M3H3 (LQFP52)	M3H2 (LQFP48) (VQFN48)	M3H1 (LQFP44)	M3H0 (LQFP32)
RXIN0	PB1	27	29	22	18	15	14	13	9
Combination functional pin name	Port Name	M3H6 (LQFP100)	M3H6 (QFP100)	M3H5 (LQFP80)	M3H4 (LQFP64)	M3H3 (LQFP52)	M3H2 (LQFP48) (VQFN48)	M3H1 (LQFP44)	M3H0 (LQFP32)
RTCOUT	PC2	56	58	46	38	33	30	-	-

Table 4.17 Debug pins

Combination functional pin name	Port Name	M3H6 (LQFP100)	M3H6 (QFP100)	M3H5 (LQFP80)	M3H4 (LQFP64)	M3H3 (LQFP52)	M3H2 (LQFP48) (VQFN48)	M3H1 (LQFP44)	M3H0 (LQFP32)
TMS	PK2	79	81	64	52	43	40	36	29
TCK	PK3	80	82	65	53	44	41	37	30
TDO	PK4	81	83	66	54	45	42	38	-
TDI	PK5	82	84	67	55	46	43	39	-
TRST_N	PK6	83	85	68	56	-	-	-	-
SWDIO	PK2	79	81	64	52	43	40	36	29
SWCLK	PK3	80	82	65	53	44	41	37	30
SWV	PK4	81	83	66	54	45	42	38	-
TRACECLK	PM0	25	27	20	16	-	-	-	-
TRACEDATA0	PM1	24	26	19	15	-	-	-	-
TRACEDATA1	PM2	23	25	18	14	-	-	-	-
TRACEDATA2	PM3	22	24	-	-	-	-	-	-
TRACEDATA3	PM4	21	23	-	-	-	-	-	-

Table 4.18 Control Pins

Pin Name	Port Name	M3H6 (LQFP100)	M3H6 (QFP100)	M3H5 (LQFP80)	M3H4 (LQFP64)	M3H3 (LQFP52)	M3H2 (LQFP48) (VQFN48)	M3H1 (LQFP44)	M3H0 (LQFP32)
X1	PH0	48	50	38	30	25	22	21	14
X2	PH1	49	51	39	31	26	23	22	15
XT1	PH2	51	53	41	33	28	25	-	-
XT2	PH3	52	54	42	34	29	26	-	-
EHCLKIN	PH0	48	50	38	30	25	22	21	14
BOOT_N	PB0	26	28	21	17	14	13	12	8
RESET_N		50	52	40	32	27	24	23	16
MODE		53	55	43	35	30	27	24	17
BSC		86	88	71	57	47	-	-	-

Table 4.19 Power Supply pins

Pin Name	M3H6 (LQFP100)	M3H6 (QFP100)	M3H5 (LQFP80)	M3H4 (LQFP64)	M3H3 (LQFP52)	M3H2 (LQFP48) (VQFN48)	M3H1 (LQFP44)	M3H0 (LQFP32)
DVDD5A	44	46	34	26	21	18	17	10
DVDD5B	87	89	72	58	-	-	-	-
DVDD5C	10	12	9	-	-	-	-	-
DVSSA	47	49	37	29	24	21	20	13
DVSSB	88	90	73	59	-	-	-	-
DVSSC	9	11	8	-	-	-	-	-
REGOUT1	46	48	36	28	23	20	19	12
REGOUT2	45	47	35	27	22	19	18	11
AVDD5	5	7	4	4	4	4	4	3
AVSS	6	8	5	5	5	5	5	4
Pin Name	M3H6 (LQFP100)	M3H6 (QFP100)	M3H5 (LQFP80)	M3H4 (LQFP64)	M3H3 (LQFP52)	M3H2 (LQFP48) (VQFN48)	M3H1 (LQFP44)	M3H0 (LQFP32)
PB7	33	35	-	-	-	-	-	-
PC6	60	62	50	-	-	-	-	-
PR3	64	66	-	-	-	-	-	-

4.3. Ports

The symbols of each table of the port have the following meanings.

The right-hand side of the port shows specification with the symbol.

The symbols have the following meanings.

- Input/Output: Input or/and Output of Port
Input: Input port
Output: Output port
I/O: Input/Output port
- PU/PD: Programmable pull-up/pull-down
PU: Programmable pull-up is selectable
PD: Programmable pull-down is selectable
- OD: Programmable open-drain output
Yes: Support
No: Non support
- 5V_T: 5V-tolerant
Yes: Support
N/A: Not available
- SMT/CMOS: Input gate
SMT: Schmitt trigger input
CMOS: CMOS input
- Under Reset: Port state under Reset
Hi-z: High impedance
PU: Pull-up
PD: Pull-down
- After Reset: Port state after Reset
Hi-z: High impedance
PU: Pull-up
PD: Pull-down

4.3.1. Port Specification Table

Table 4.20 Port names, and specifications of Port A, B, C, D, E, F

Port Name	Input/Output	PU/PD	OD	5V_T	SMT/CMOS	Under Reset	After Reset
PA0	I/O	PU/PD	YES	N/A	SMT	Hi-z	Hi-z
PA1	I/O	PU/PD	YES	N/A	SMT	Hi-z	Hi-z
PA2	I/O	PU/PD	YES	N/A	SMT	Hi-z	Hi-z
PA3	I/O	PU/PD	YES	N/A	SMT	Hi-z	Hi-z
PA4	I/O	PU/PD	YES	YES	SMT	Hi-z	Hi-z
PA5	I/O	PU/PD	YES	YES	SMT	Hi-z	Hi-z
PA6	I/O	PU/PD	YES	N/A	SMT	Hi-z	Hi-z
PA7	I/O	PU/PD	YES	N/A	SMT	Hi-z	Hi-z
PB0	Output	PU/PD (Note)	YES	N/A	SMT	Hi-z (Note)	Hi-z
PB1	I/O	PU/PD	YES	N/A	SMT	Hi-z	Hi-z
PB2	I/O	PU/PD	YES	N/A	SMT	Hi-z	Hi-z
PB3	I/O	PU/PD	YES	N/A	SMT	Hi-z	Hi-z
PB4	I/O	PU/PD	YES	N/A	SMT	Hi-z	Hi-z
PB5	I/O	PU/PD	YES	N/A	SMT	Hi-z	Hi-z
PB6	I/O	PU/PD	YES	N/A	SMT	Hi-z	Hi-z
PB7	I/O	PU/PD	YES	N/A	SMT	Hi-z	Hi-z
PC0	I/O	PU/PD	YES	YES	SMT	Hi-z	Hi-z
PC1	I/O	PU/PD	YES	YES	SMT	Hi-z	Hi-z
PC2	I/O	PU/PD	YES	N/A	SMT	Hi-z	Hi-z
PC3	I/O	PU/PD	YES	N/A	SMT	Hi-z	Hi-z
PC4	I/O	PU/PD	YES	N/A	SMT	Hi-z	Hi-z
PC5	I/O	PU/PD	YES	N/A	SMT	Hi-z	Hi-z
PC6	I/O	PU/PD	YES	N/A	SMT	Hi-z	Hi-z
PD0	I/O	PU/PD	YES	N/A	SMT	Hi-z	Hi-z
PD1	I/O	PU/PD	YES	N/A	SMT	Hi-z	Hi-z
PD2	I/O	PU/PD	YES	N/A	SMT	Hi-z	Hi-z
PD3	I/O	PU/PD	YES	N/A	SMT	Hi-z	Hi-z
PE0	I/O	PU/PD	YES	N/A	SMT	Hi-z	Hi-z
PE1	I/O	PU/PD	YES	N/A	SMT	Hi-z	Hi-z
PE2	I/O	PU/PD	YES	N/A	SMT	Hi-z	Hi-z
PE3	I/O	PU/PD	YES	N/A	SMT	Hi-z	Hi-z
PE4	I/O	PU/PD	YES	N/A	SMT	Hi-z	Hi-z
PE5	I/O	PU/PD	YES	N/A	SMT	Hi-z	Hi-z
PE6	I/O	PU/PD	YES	N/A	SMT	Hi-z	Hi-z
PF0	I/O	PU/PD	YES	N/A	SMT	Hi-z	Hi-z
PF1	I/O	PU/PD	YES	N/A	SMT	Hi-z	Hi-z
PF2	I/O	PU/PD	YES	N/A	SMT	Hi-z	Hi-z
PF3	I/O	PU/PD	YES	N/A	SMT	Hi-z	Hi-z
PF4	I/O	PU/PD	YES	N/A	SMT	Hi-z	Hi-z

Note: combination with BOOT_N. When RESET_N=0, Pull-up resistor is enabled.
When RESET_N=1, the pin state is Hi-z with internal reset.

Table 4.21 Port names, and specifications of Port G, J, K, L, M

Port Name	Input/Output	PU/PD	OD	5V_T	SMT/CMOS	Under Reset	After Reset
PG0	I/O	PU/PD	YES	N/A	SMT	Hi-z	Hi-z
PG1	I/O	PU/PD	YES	N/A	SMT	Hi-z	Hi-z
PH0	Input	PD	N/A	N/A	SMT	Hi-z	Hi-z
PH1	Input	PD	N/A	N/A	SMT	Hi-z	Hi-z
PH2	Input	PD	N/A	N/A	SMT	Hi-z	Hi-z
PH3	Input	PD	N/A	N/A	SMT	Hi-z	Hi-z
PJ0	I/O	PU/PD	YES	N/A	SMT	Hi-z	Hi-z
PJ1	I/O	PU/PD	YES	N/A	SMT	Hi-z	Hi-z
PJ2	I/O	PU/PD	YES	N/A	SMT	Hi-z	Hi-z
PJ3	I/O	PU/PD	YES	N/A	SMT	Hi-z	Hi-z
PJ4	I/O	PU/PD	YES	N/A	SMT	Hi-z	Hi-z
PJ5	I/O	PU/PD	YES	N/A	SMT	Hi-z	Hi-z
PK0	I/O	PU/PD	YES	N/A	SMT	Hi-z	Hi-z
PK1	I/O	PU/PD	YES	N/A	SMT	Hi-z	Hi-z
PK2	I/O	PU/PD	YES	N/A	SMT	PU(Note)	PU(Note)
PK3	I/O	PU/PD	YES	N/A	SMT	PD(Note)	PD(Note)
PK4	I/O	PU/PD	YES	N/A	SMT	Hi-z (Note)	Hi-z (Note)
PK5	I/O	PU/PD	YES	N/A	SMT	PU(Note)	PU(Note)
PK6	I/O	PU/PD	YES	N/A	SMT	PU(Note)	PU(Note)
PK7	I/O	PU/PD	YES	N/A	SMT	Hi-z	Hi-z
PL0	I/O	PU/PD	YES	YES	SMT	Hi-z	Hi-z
PL1	I/O	PU/PD	YES	YES	SMT	Hi-z	Hi-z
PL2	I/O	PU/PD	YES	N/A	SMT	Hi-z	Hi-z
PL3	I/O	PU/PD	YES	N/A	SMT	Hi-z	Hi-z
PL4	I/O	PU/PD	YES	N/A	SMT	Hi-z	Hi-z
PL5	I/O	PU/PD	YES	N/A	SMT	Hi-z	Hi-z
PL6	I/O	PU/PD	YES	N/A	SMT	Hi-z	Hi-z
PM0	I/O	PU/PD	YES	N/A	SMT	Hi-z	Hi-z
PM1	I/O	PU/PD	YES	N/A	SMT	Hi-z	Hi-z
PM2	I/O	PU/PD	YES	N/A	SMT	Hi-z	Hi-z
PM3	I/O	PU/PD	YES	N/A	SMT	Hi-z	Hi-z
PM4	I/O	PU/PD	YES	N/A	SMT	Hi-z	Hi-z
PM5	I/O	PU/PD	YES	N/A	SMT	Hi-z	Hi-z
PM6	I/O	PU/PD	YES	N/A	SMT	Hi-z	Hi-z

Note: It is assigned to a debugging pin in the state of the initial stage. (PK2:TMS/SWDIO, PK3:TCK/SWCLK, PK4:TDO/SWV, PK5:TDI, PK6: TRST_N)

Table 4.22 Port names, and specifications of Port N, P, R

Port Name	Input/Output	PU/PD	OD	5V_T	SMT/CMOS	Under Reset	After Reset
PN0	I/O	PU/PD	YES	N/A	SMT	Hi-z	Hi-z
PN1	I/O	PU/PD	YES	N/A	SMT	Hi-z	Hi-z
PN2	I/O	PU/PD	YES	N/A	SMT	Hi-z	Hi-z
PN3	I/O	PU/PD	YES	N/A	SMT	Hi-z	Hi-z
PN4	I/O	PU/PD	YES	N/A	SMT	Hi-z	Hi-z
PN5	I/O	PU/PD	YES	N/A	SMT	Hi-z	Hi-z
PP0	I/O	PU/PD	YES	N/A	SMT	Hi-z	Hi-z
PP1	I/O	PU/PD	YES	N/A	SMT	Hi-z	Hi-z
PP2	I/O	PU/PD	YES	N/A	SMT	Hi-z	Hi-z
PP3	I/O	PU/PD	YES	N/A	SMT	Hi-z	Hi-z
PR0	I/O	PU/PD	YES	N/A	SMT	Hi-z	Hi-z
PR1	I/O	PU/PD	YES	N/A	SMT	Hi-z	Hi-z
PR2	I/O	PU/PD	YES	N/A	SMT	Hi-z	Hi-z
PR3	I/O	PU/PD	YES	N/A	SMT	Hi-z	Hi-z

5. Functional Description and Operation Description

5.1. Reference Manuals

For more information on the product of TMPM3H Group(1), please refer to Reference Manuals below;

Table 5.1 Reference Manuals for TMPM3H Group(1)

Reference Manual	IP Symbol	Category
Port (TMPM3H group(1))	PORT-M3H(1)	System
Memory Map (TMPM3H group(1))	MMAP-M3H(1)	System
Exception (TMPM3H group(1))	EXCEPT-M3H(1)	System
Clock Control and operation mode (TMPM3H group(1))	CG-M3H(1)-D	System
Product Information (TMPM3H group(1))	PINFO-M3H(1)	System
Power supply and Reset operation (TMPM3H group(1))	RESET-M3H(1)	System
Flash Memory (128KB Code FLASH and 32KB Data FLASH)	FLASH128_32-A	Peripheral
Trimming Circuit	TRM-A	Peripheral
Oscillation Frequency Detector	OFD-A	Peripheral
Voltage Detection Circuit	LVD-A	Peripheral
Digital Noise Filter Circuit	DNF-A	Peripheral
Debug Interface	DEBUG-A	Peripheral
DMA Controller	DMAC-B	Peripheral
Asynchronous Serial Communication Circuit	UART-C	Peripheral
Serial Peripheral Interface	TSPI-B	Peripheral
I ² C interface	I2C-B	Peripheral
8-bit Digital to Analog Converter	DAC-A	Peripheral
12-bit Analog to Digital Converter	ADC-A	Peripheral
Programmable Motor Control Circuit plus	PMD+-A	Peripheral
Advanced Encoder Input Circuit	A-ENC-A	Peripheral
32-bit Timer Event Counter	T32A-B	Peripheral
Real Time Clock	RTC-A	Peripheral
Clock Selective Watchdog Timer	SIWDT-A	Peripheral
Remote Control Signal Preprocessor	RMC-A	Peripheral
Boundary Scan	BSC-A	Peripheral

5.2. Processor Core

The TMPM3H Group(1) incorporates a high-performance 32-bit processor core (Arm Cortex-M3 core).

For the operation of the processor core, refer to the Arm documentation set of the Arm "Cortex-M" series processor. This section explains the product-specific information.

5.2.1. Core Information

The Cortex-M3 core revision used in the TMPM3H Group(1) is shown as below:

For details of the CPU core and the architecture, refer to the documentation of the Arm in the following URL:

<http://infocenter.arm.com/help/index.jsp>

Table 5.2 Core revision

Group name	Core revision
TMPM3H Group(1)	r2p1

5.2.2. Configurable Options

In the Cortex-M3 core, some blocks can be selected to implement. The following table shows the configurations of the TMPM3H Group(1).

Table 5.3 Configurable options and their implementations

Configurable option	Implementation
FWB	Literal comparator: 2 Instruction comparator: 6
DWT	Comparator: 4
ITM	Available
MPU	Available
ETM	Available
AHB-AP	Available
AHB trace macro cell interface	Not available
TPIU	Available
WIC	Not available
Debug port	JTAG/serial wire
Bit band	Available
Sequential control of AHB	Not available

5.3. Clock Control and Operation mode (CG)

The CG selects a clock gear ratio and the prescaler clock, or warm up time of the oscillator.

There are NORMAL mode and low-power consumption mode as operation modes. Power consumption can be decreased by mode transition.

The outline of the clock control circuit is as follows:

- Internal high-speed oscillation circuit: 10MHz
- Selectable from the external high-speed oscillation circuit or internal high-speed oscillation circuit.
- PLL (Clock Multiplication Circuit): Capable of 40 MHz output by changing the multiplication ratio according to the frequency of the high-speed oscillation circuit
- Clock gear: The high-speed clock can be divided by 1/1, 1/2, 1/4, 1/8, or 1/16 and the clock is used as the system clock (fsys).
- Low-power consumption mode:
 - IDLE: Only the CPU is stopped in this mode. Each peripheral circuit can enable or disable operation in the IDLE mode.
 - STOP1: Except some peripheral circuits, all the internal circuits including the internal oscillator are brought to a stop in STOP1 mode. External low frequency oscillator can oscillate. RTC and RMC can be used.
 - STOP2: This mode halts voltage supply, retaining some peripheral circuits operation. External low frequency oscillator can oscillate (RTC can be used.), and wake-up by I²C slave address matching.

5.4. Flash Memory (Code FLASH, Data FLASH)

The code flash stores instruction code, and CPU reads instruction code and executes. The data flash stores data, and even if a power supply is off, data can be kept.

It has the dual mode that possible to write and erase a data flash while executing an order by a code flash, and it's also possible to continue executing an application program during writing or erasing data flash.

It has protection function which prohibits write or erase by the block unit and it has the security function which prohibits the reading of the program code by the 3rd person.

5.5. Oscillation Circuit

External High Speed Oscillator (EHOSC): Connect crystal resonator or ceramic resonator to terminals. Use clock source for System clock.

External Low Speed Oscillator (ELOSC): Connect crystal resonator (32.768 kHz) to terminals. Use clock source for Real Time Clock or Power consumption mode.

Internal High Speed Oscillator 1(IHOSC1): Oscillation frequency is 10MHz. Use clock source for System clock.

Internal High Speed Oscillator 2(IHOSC2): Oscillation frequency is 10MHz. Use clock source for OFD and SIWDT.

Table 5.4 Built-in Oscillator

	M3H6	M3H5	M3H4	M3H3	M3H2	M3H1	M3H0
EHOSC	✓	✓	✓	✓	✓	✓	✓
ELOSC	✓	✓	✓	✓	✓	-	-
IHOSC1	✓	✓	✓	✓	✓	✓	✓
IHOSC2	✓	✓	✓	✓	✓	✓	✓

Note: ✓: Available, -: N/A

5.6. Trimming Circuit (TRM)

The trimming function can adjust frequency of the internal high-speed oscillator 1 (IHOSC1).

In the coarse trimming, -20.4% to +33.0% adjustment by 0.8%-step is feasible. In the delicate trimming, -0.8% to +0.7% adjustment by 0.1%-step is feasible.

Table 5.5 Built-in TRM

	M3H6	M3H5	M3H4	M3H3	M3H2	M3H1	M3H0
TRM	✓	✓	✓	✓	✓	✓	✓

Note: ✓: Available, -: N/A

5.7. Oscillation Frequency Detection Circuit (OFD)

The oscillation frequency detection circuit (OFD) is a function that detects an abnormal state of the clock. It measures the external high-speed oscillation (f_{EHOSC}) or high-speed clock (f_c) based on the internal reference clock (f_{IHOSC2}). If an oscillation or clock frequency is out of the specified range, a reset signal occurs.

The upper limit and the lower limit of detection frequency ranges can be specified respectively.

Table 5.6 Built-in OFD

	M3H6	M3H5	M3H4	M3H3	M3H2	M3H1	M3H0
OFD	✓	✓	✓	✓	✓	✓	✓

Note: ✓: Available, -: N/A

5.8. Voltage Detection Circuit (LVD)

The LVD is a peripheral function that detects whether a power supply voltage is lower or higher than the preset voltage. When a low voltage or higher voltage than the preset voltage is detected, the LVD generates an interrupt request or reset the MCU.

Setting voltage can be chosen from eight kinds. LVD is set to enable from the Reset state at the Power-on.

Table 5.7 Built-in LVD

	M3H6	M3H5	M3H4	M3H3	M3H2	M3H1	M3H0
LVD	✓	✓	✓	✓	✓	✓	✓

Note: ✓: Available, -: N/A

5.9. Digital Noise Filter (DNF)

The digital noise canceler circuit can eliminate noise of input signals from external interrupt pins at the certain range. The noise of the High level / Low level input of the external interrupt signal INTx is removed.

Table 5.8 Number of External Interrupt (Built-in DNF)

	M3H6	M3H5	M3H4	M3H3	M3H2	M3H1	M3H0
Number of External Interrupt	16	15	11	8	7	6	6

5.10. Debug Interface (DEBUG)

TMPM3H group(1) contain Interface for connect debug tool, which is the Serial Wire Debug Port (SWCLK, SWDIO) and the JTAG Debug Port (TDI, TDO, TMS, TCK, TRST_N). These are connected with the Debug tool and used for program development. And also it contains the trace clock (TRACECLK) and data output (TRACEDATA0to3) to reduce the Debug Process.

Table 5.9 Built-in Debug Interface

Pin Name	Port	M3H6	M3H5	M3H4	M3H3	M3H2	M3H1	M3H0
TMS/SWDIO	PK2	✓	✓	✓	✓	✓	✓	✓
TCK/SWCLK	PK3	✓	✓	✓	✓	✓	✓	✓
TDO/SWV	PK4	✓	✓	✓	✓	✓	✓	-
TDI	PK5	✓	✓	✓	✓	✓	✓	-
TRST_N	PK6	✓	✓	✓	-	-	-	-
TRACECLK	PM0	✓	✓	✓	-	-	-	-
TRACEDATA0	PM1	✓	✓	✓	-	-	-	-
TRACEDATA1	PM2	✓	✓	✓	-	-	-	-
TRACEDATA2	PM3	✓	-	-	-	-	-	-
TRACEDATA3	PM4	✓	-	-	-	-	-	-

Note: ✓: Available, -: N/A

5.11. DMA Controller (DMAC)

The DMAC is the peripheral function to move the data between peripheral functions and the memory, or between memories. These operations are performed separately from the CPU control; thus, the Load of CPU can greatly be reduced by using the DMA.

TMPM3H Group (1) product has one DMA controller (DMAC) unit, and there are up to 32 channels of activation factors per unit.

Table 5.10 Built-in DMAC

UNIT	M3H6	M3H5	M3H4	M3H3	M3H2	M3H1	M3H0
UNIT A	✓	✓	✓	✓	✓	✓	✓

Note: ✓: Available, -: N/A

5.12. Asynchronous Serial Communication Circuit (UART)

The UART is asynchronous serial communication function. It can choose the data length of 7, 8 or 9bits, parity existence, and a STOP bit length function. Moreover, selection of the MSB first / LSB first and reversal of data polarity can be performed and Terminal exchanged of TXD/RXD can be performed in a Port setting.

The FIFO buffer supports data communication on 8-stage at transmission; and on 8-stage at reception.

The telecommunication control by CTS/RTS and half clock mode are supported.

Table 5.11 Built-in UART

Channel	M3H6	M3H5	M3H4	M3H3	M3H2	M3H1	M3H0
Channel 0	✓	✓	✓	✓	✓	✓	✓
Channel 1	✓	✓	✓	✓	✓	✓	✓
Channel 2	✓	✓	✓	✓	✓	✓	-

Note1: ✓: Available, -: N/A

Note2: External pins are not same by product. Please refer to section "2 Pin Assignment".

5.13. Serial Peripheral Interface (TSPI)

The TSPI supports two communication methods and enables to perform serial communication between other devices at high speed. The SPI bus type, which uses a CS (Chip Select) signal at communications, and SIO bus type, which does not use a CS signal at communications can be selected.

The data length can be changed from 7 bits (with a parity bit) to 32 bits (without a parity bit) in the unit of one bit. There are an 8-stage 16-bit FIFO for reception and transmission, each. The TSPI supports master and slave communications.

Table 5.12 Built-in TSPI

Channel	M3H6	M3H5	M3H4	M3H3	M3H2	M3H1	M3H0
Channel 0	✓	✓	✓	✓	✓	✓	✓
Channel 1	✓	✓	✓	✓	✓	✓	-

Note1: ✓: Available, -: N/A

Note2: External pins are not same by product. Please refer to section "2 Pin Assignment".

5.14. I²C Interface (I²C)

I²C is two-wire bi-directional serial communications between Master and Slave device. The mode in which two or more masters can exist on the same bus called a multi-master is supported. It supports STD mode (Max 100kbps), Fast mode (Max 400kbps), and Fast mode plus; Fm+ (Max 1Mbps).

Channel 0 provides the address match wake up function. Depending on the setting, the MCU can receive data even in low-power consumption mode including IDLE, STOP1, or STOP2 mode and can return to normal mode by the Slave address match wake up function. (Note2)

Table 5.13 Built-in I²C

Channel	M3H6	M3H5	M3H4	M3H3	M3H2	M3H1	M3H0
Channel 0 (Note2)	✓	✓	✓	✓	✓	✓	✓
Channel 1	✓	✓	✓	✓	✓	✓	-
Channel 2	✓	✓	✓	✓	-	-	-

Note1: ✓: Available, -: N/A

Note2: The address match wake up function is available.

5.15. 8-bit Digital-to-Analog Converter (DAC)

The DAC is an R-2R type 8-bit digital-to-analog converter that can output the specified voltage. A buffer amplifier is not incorporated.

Table 5.14 Built-in DAC

Channel	M3H6	M3H5	M3H4	M3H3	M3H2	M3H1	M3H0
Channel 0	✓	✓	✓	✓	✓	-	-
Channel 1	✓	✓	-	-	-	-	-

Note: ✓: Available, -: N/A

5.16. 12-bit Analog-to-Digital Converter (ADC)

The ADC is a successive-approximation analog-to-digital converter. It supports maximum 16 analog inputs. The combination of a conversion result register and analog input can be programmed in each startup trigger of AD conversion. A startup trigger for analog-to-digital conversion can be selected from software or peripheral functions (PMD trigger outputs, timer/event counter outputs, port inputs).

The monitor function is also available and it can generate an interrupt request when the compare conditions are matched.

Table 5.15 Built-in ADC

UNIT	M3H6	M3H5	M3H4	M3H3	M3H2	M3H1	M3H0
UNIT A	✓	✓	✓	✓	✓	✓	✓

Note: ✓: Available, -: N/A

Table 5.16 Number of analog inputs for ADC

	M3H6	M3H5	M3H4	M3H3	M3H2	M3H1	M3H0
Analog Inputs Pin count	16	10	8	8	8	8	4

5.17. Motor Control Circuit Plus (PMD+)

The motor control circuit plus (PMD+) enables users to control brushless DC motors easily. It incorporates the three-phase pulse modulation circuit and dead-time circuit, and easily generates waveforms for motor control by operating with the ADC in a coordinated fashion.

It also provides the over-voltage detection input and abnormal detection input to support safety measures.

Table 5.17 Built-in PMD+

Channel	M3H6	M3H5	M3H4	M3H3	M3H2	M3H1	M3H0
Channel 0	✓	✓	✓	✓	✓	✓	✓

Note: ✓: Available, -: N/A

5.18. Advanced Encoder Input Circuit (A-ENC)

The advanced encoder input circuit (A-ENC) supports an incremental encoder to acquire the motor position easily. The noise canceller is installed in the input pins, so that the signals from an incremental encoder or Hall sensor can be input directly.

The A-ENC provides six operation modes: encoder mode, sensor modes (3 kinds), timer mode, and phase counter mode.

Table 5.18 Built-in A-ENC

Channel	M3H6	M3H5	M3H4	M3H3	M3H2	M3H1	M3H0
Channel 0	✓	✓	✓	✓	✓	✓	✓

Note: ✓: Available, -: N/A

5.19. 32-bit Timer Event Counter (T32A)

The T32A is a timer event counter that can operate as a 32-bit timer or two 16-bit timers. 16-bit Timer or 32-bit Timer can be selected. In 16-bit Timer, the T32A is comprised of Timer A and Timer B incorporating a 16-bit counter respectively. In 32-bit Timer, the T32A operates as Timer C incorporating a 32-bit counter.

The T32A have a interval timer, event counter, input capture, 2-phase counter input, PPG output, Synchronous Start, and Trigger start/stop functions.

Table 5.19 Built-in T32A

Channel	M3H6	M3H5	M3H4	M3H3	M3H2	M3H1	M3H0
Channel 0	✓	✓	✓	✓	✓	✓	✓
Channel 1	✓	✓	✓	✓	✓	✓	✓
Channel 2	✓	✓	✓	✓	✓	✓	✓
Channel 3	✓	✓	✓	✓	✓	✓	✓
Channel 4	✓	✓	✓	✓	✓	✓	✓
Channel 5	✓	✓	✓	✓	✓	✓	✓

Note1: ✓: Available, -: N/A

Note2: External pins are not same by product. Please refer to section "2 Pin Assignment".

5.20. Real Time Clock (RTC)

The RTC is a peripheral function that has a second counter, clock function, and leap-year calendar function. It also has the alarm function that generates an interrupt on a specified time and date.

Since the RTC operates on a low-speed external oscillation clock, it can operate in low-power consumption mode such as IDLE, STOP1 or STOP2 modes. In addition, the MCU can be returned from low-power consumption mode by an interrupt request of the RTC.

The RTC easily corrects a gain/loss of the clock caused by an error of low-speed oscillation frequency using the clock correction function.

Table 5.20 Built-in RTC

	M3H6	M3H5	M3H4	M3H3	M3H2	M3H1	M3H0
RTC	✓	✓	✓	✓	✓	-	-

Note: ✓: Available, -: N/A

5.21. Clock Selective Watchdog Timer (SIWDT)

The SIWDT is a peripheral function that detects an overflow of the binary counter and generates an interrupt request or resets the MCU. This state occurs when a binary counter cannot be cleared within the preset detection time.

The count clock can be selected from three clocks: system clock ($f_{sys}/4$), internal oscillator 1 (f_{IHOSC1}), or internal oscillator 2 (f_{IHOSC2}).

It also provides the count-clear window function that can clear the count only for the specified period.

Moreover, change of a register can be forbidden until reset starts by setting to protected mode.(the count-clear function is possible)

Table 5.21 Built-in SIWDT

	M3H6	M3H5	M3H4	M3H3	M3H2	M3H1	M3H0
SIWDT	✓	✓	✓	✓	✓	✓	✓

Note: ✓: Available, -: N/A

5.22. Remote signal receive Circuit (RMC)

The RMC is a peripheral function that receives signals excluding carrier signal from remote control reception signals. The RMC detects a leader signal to receive 72 bits data in a collective manner. Two data formats can be received: synchronous format and fixed-synchronous phase format.

In addition, it contains a digital noise canceller to avoid external noise.

Since the RMC operates on a low-frequency clock, it can operate in low power consumption mode, such as IDLE mode or STOP1 mode according to the setting (except STOP2). The MCU can also be returned from low-power consumption mode by an interrupt request of the RMC.

Table 5.22 Built-in RMC

Channel	M3H6	M3H5	M3H4	M3H3	M3H2	M3H1	M3H0
Channel0	✓	✓	✓	✓	✓	✓	✓

Note: ✓: Available, -: N/A

5.23. Boundary Scan (BSC)

Boundary-Scan support the on-board Test. The TMPM3H group(1) provides a boundary-scan interface that is compatible with Joint Test Action Group (JTAG) specifications and uses the industry-standard JTAG protocol (IEEE Standard 1149.1·1990 <Includes IEEE Standard 1449.1a·1993>).

Table 5.23 Built-in BSC

	M3H6	M3H5	M3H4	M3H3	M3H2	M3H1	M3H0
Boundary Scan	✓	✓	✓	✓	-	-	-

Note: ✓: Available, -: N/A

6. Equivalent Circuit

Basically, the gate symbols written are the same as those used for the standard CMOS logic IC [74HCXX] series.

The input protection resistance ranges from several tens of Ω to several hundred Ω . Feedback resistor and Damping resistor are shown with a typical value.

Note: The resistance without the statement of the numerical value in the figure shows input protection resistance.

6.1. Port

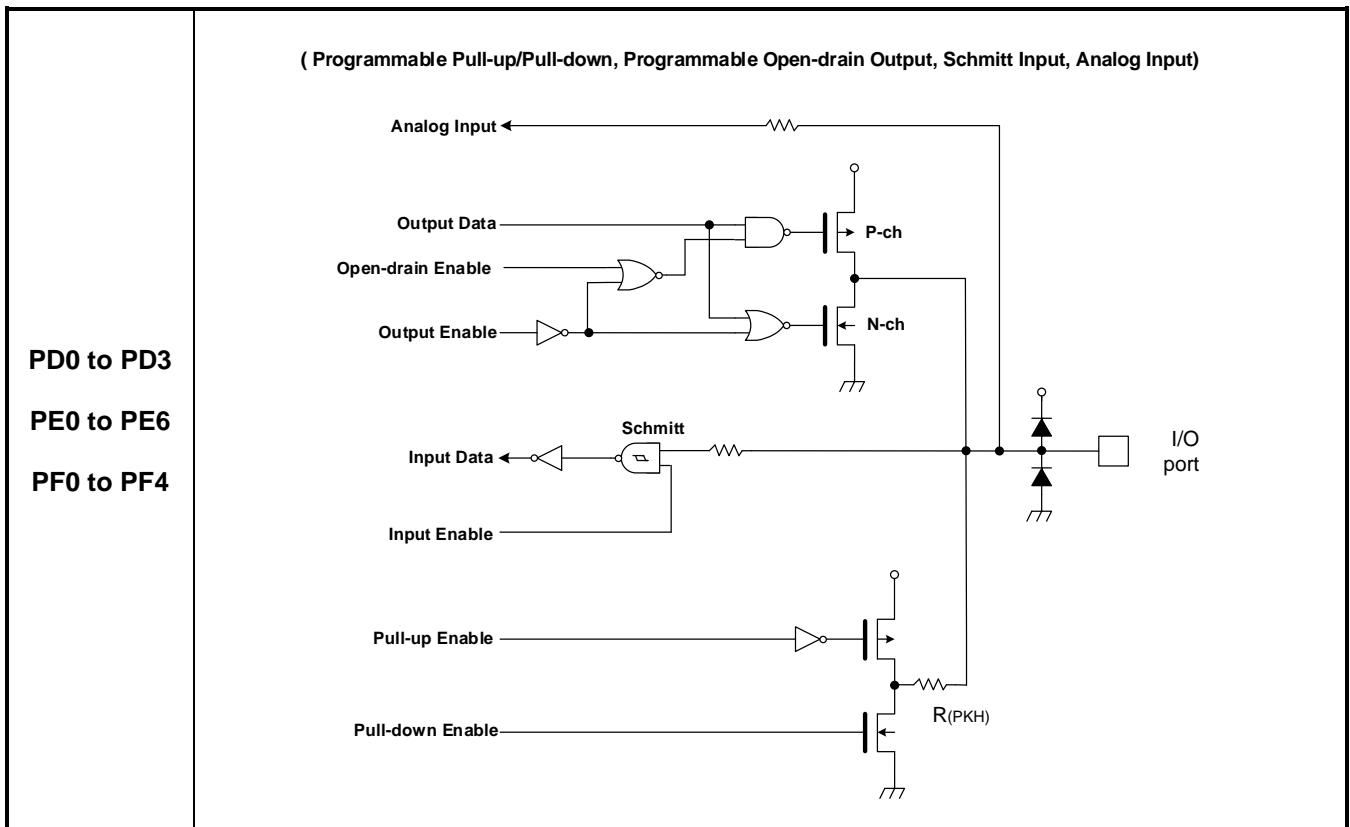

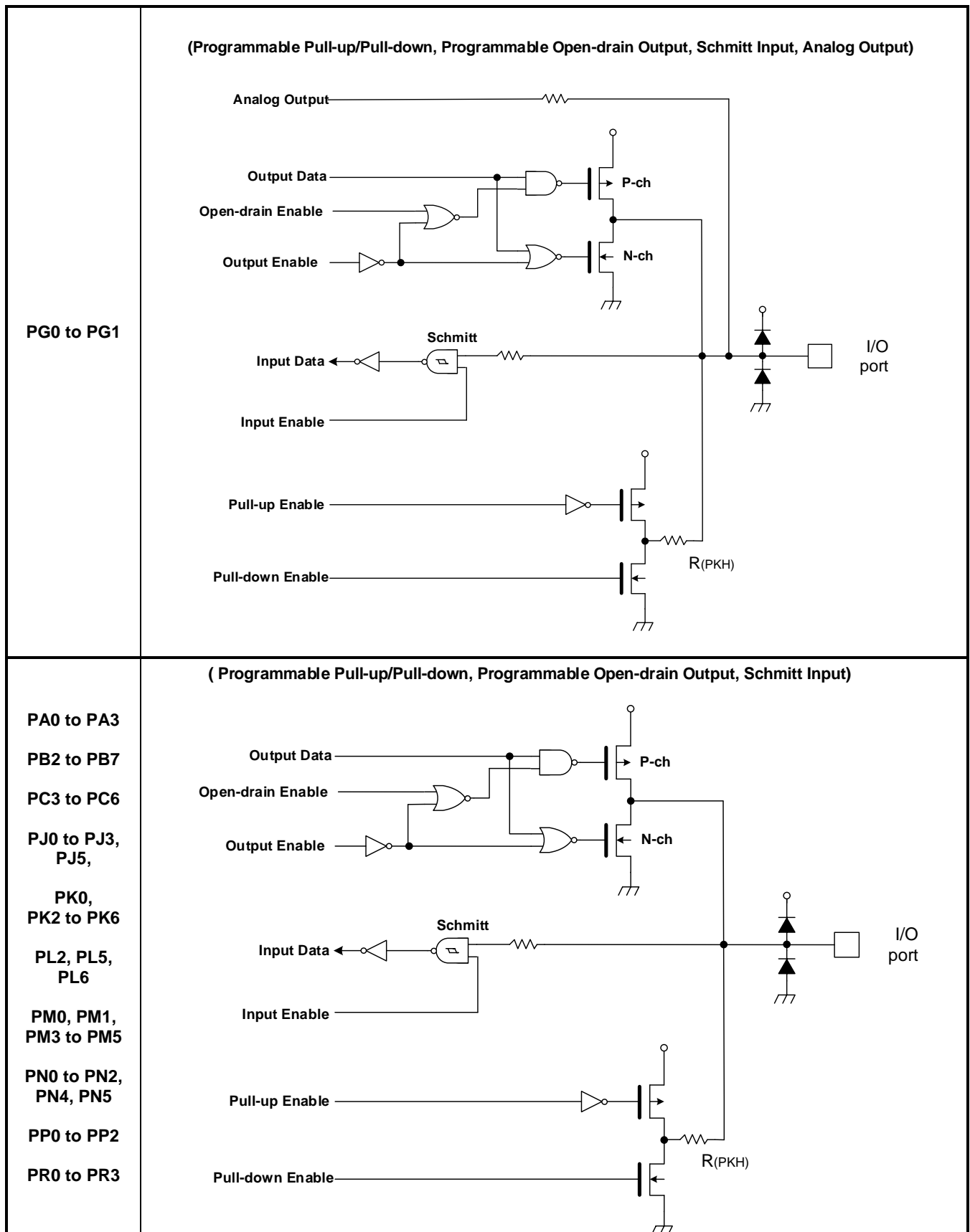

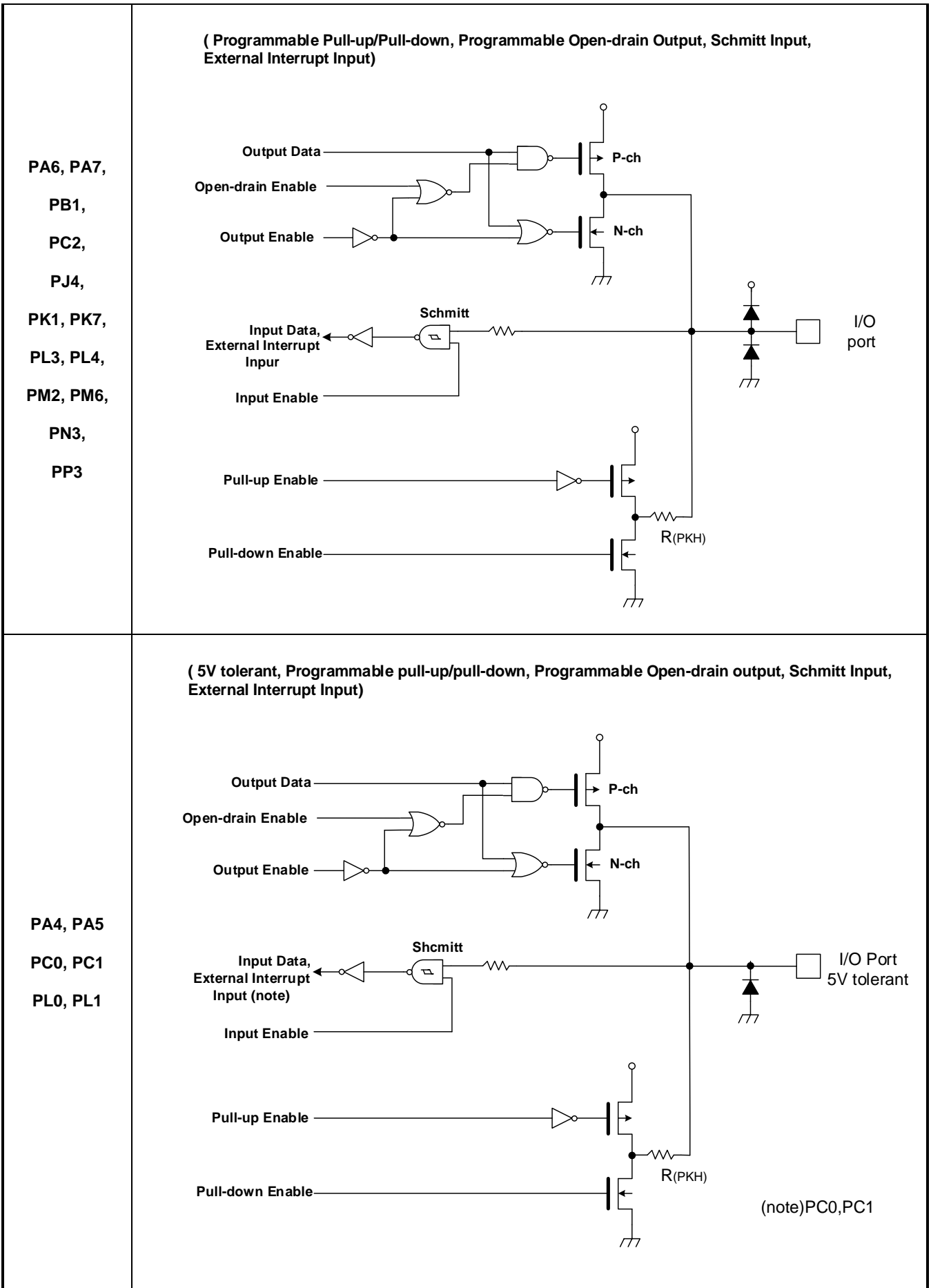

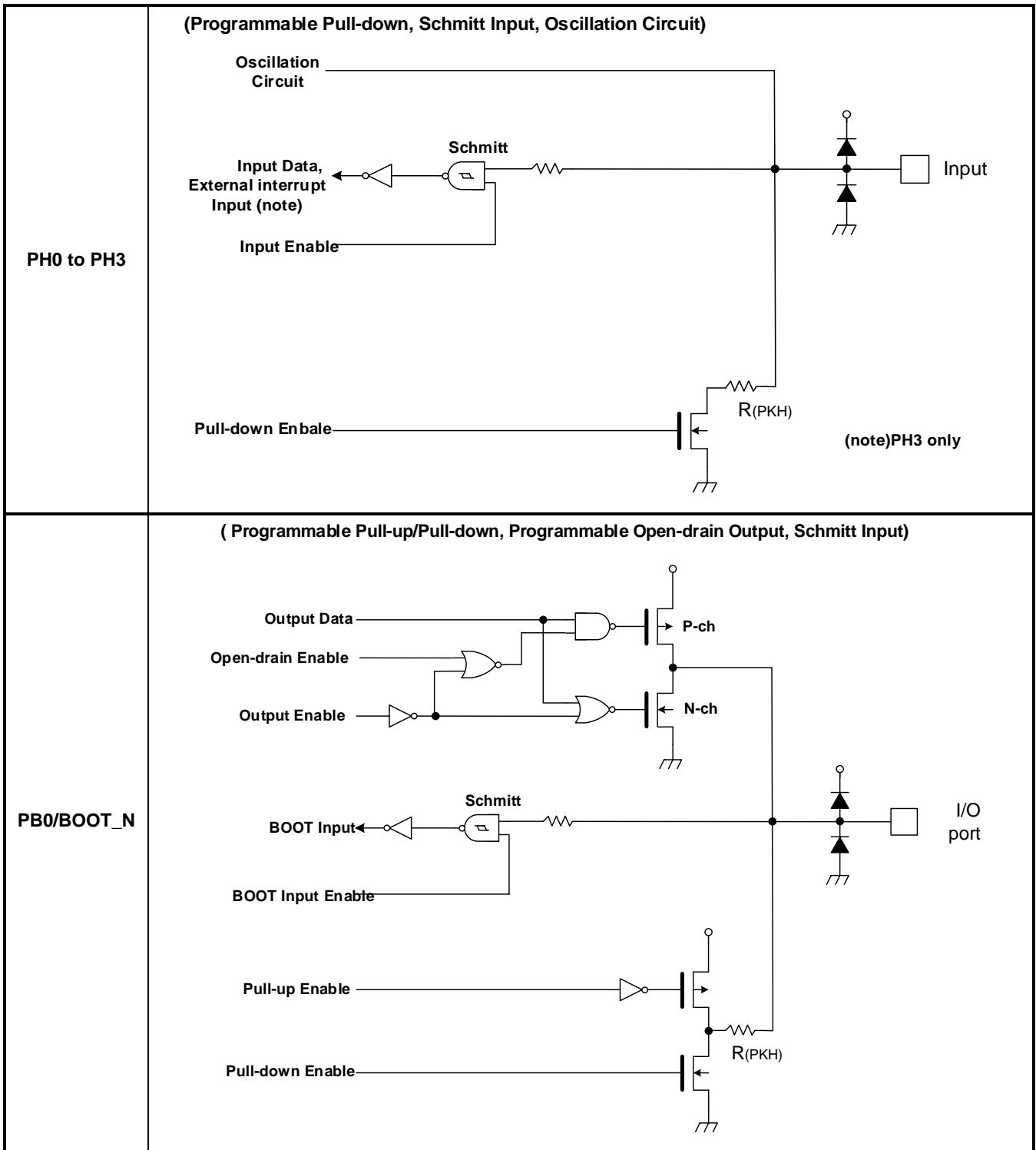

6.2. Analog Power pin

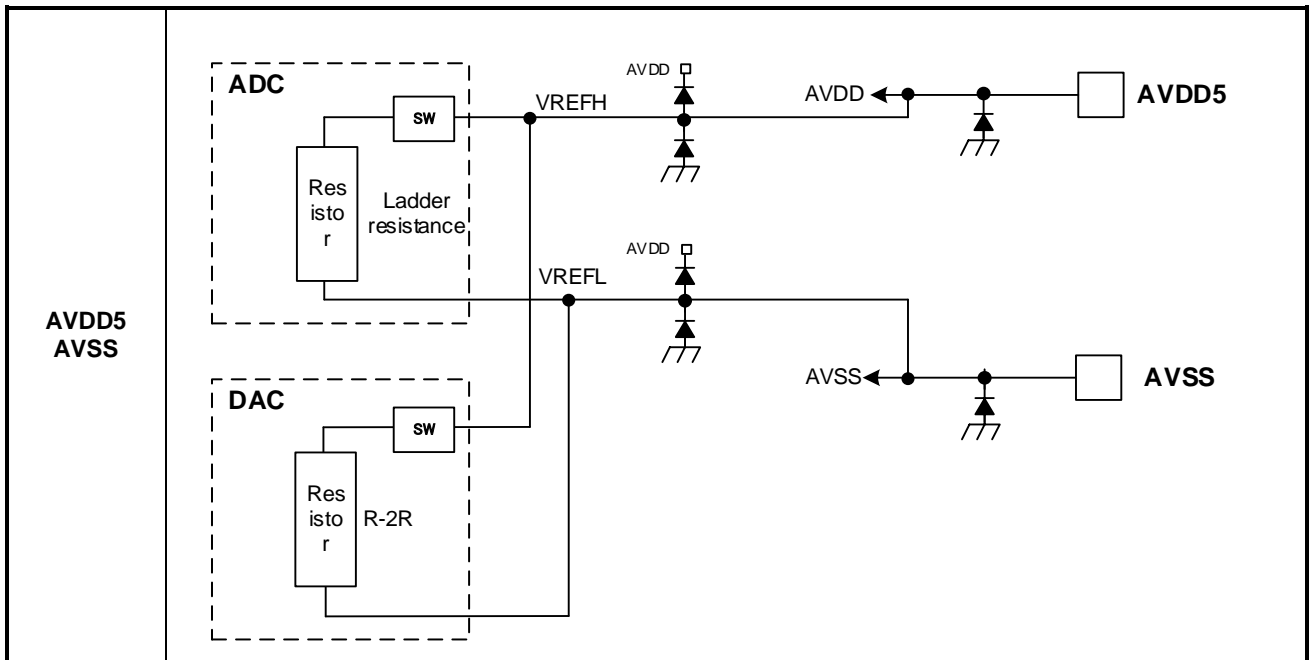

Note: SW: ON/OFF Switch Circuit

6.3. Control Pin

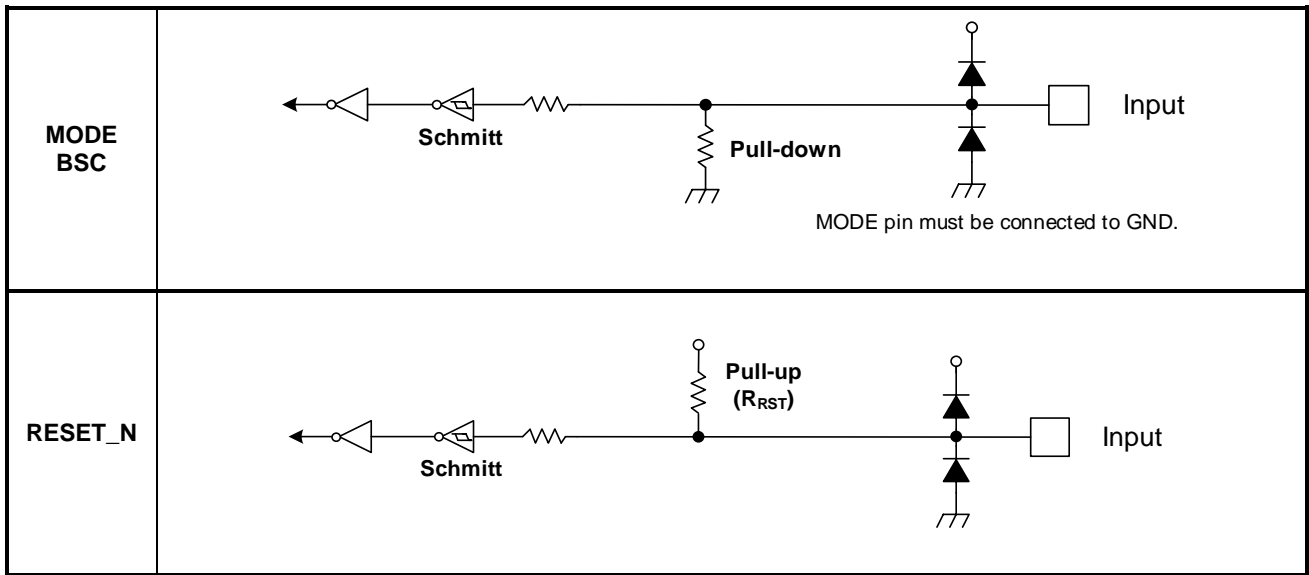

6.4. Clock control

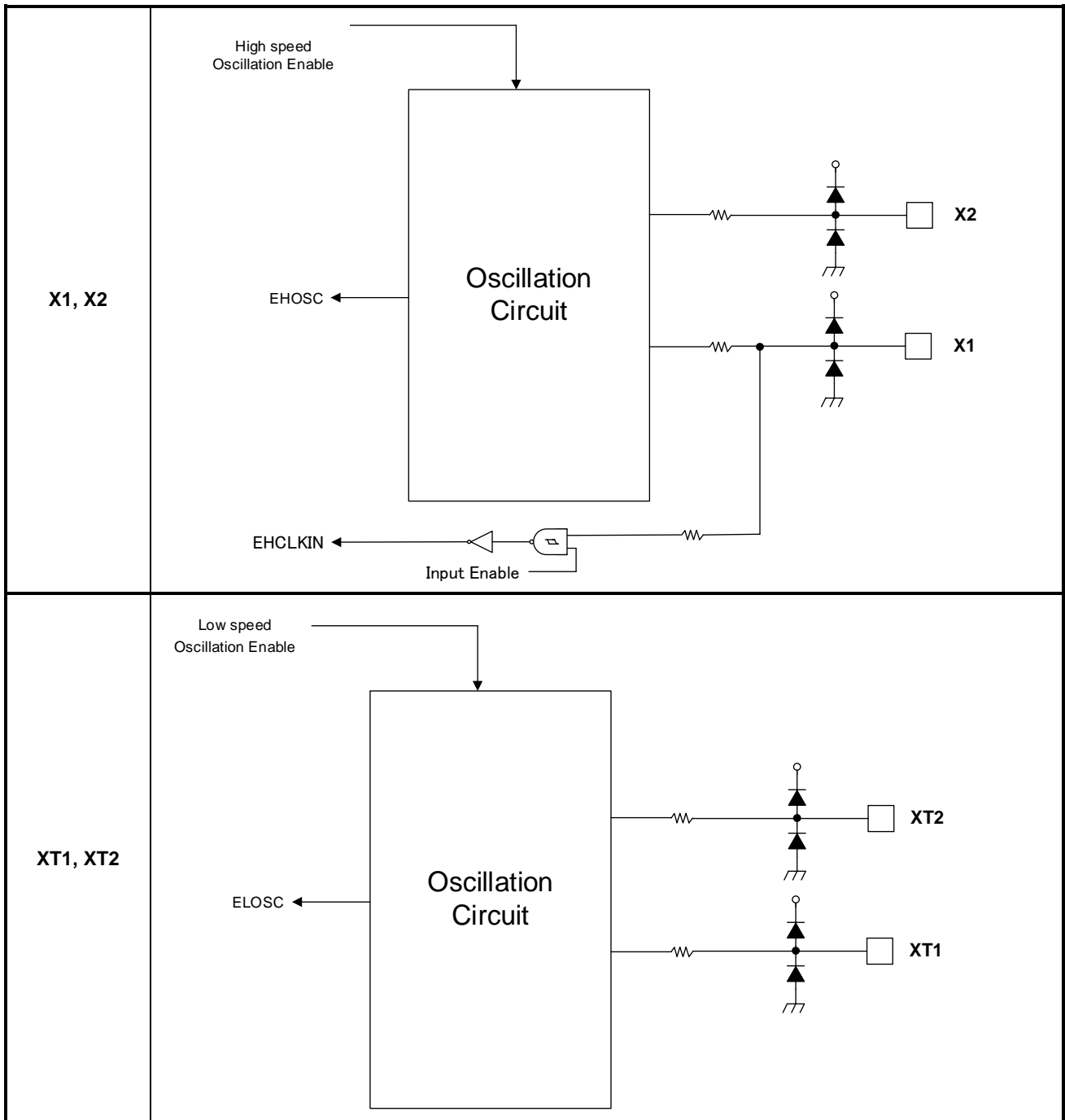

7. Electrical Characteristics

7.1. Absolute Maximum Ratings

Table 7.1 Absolute maximum ratings

Parameter		Symbol	Rating	Unit
Power supply voltage		DVDD5A DVDD5B DVDD5C	-0.3 to 6.0	V
		AVDD5	-0.3 to DVDD5 (Note1)	
Capacitor pin voltage for voltage maintenance		REGOUT1	-0.3 to 1.7	V
		REGOUT2	-0.3 to 3.9	
Input voltage	PA0to3, PA6to7, PB1to7, PC2to6, PH0to3, PJ0to5, PK0to7, PL2to6, PM0to6, PN0to5, PP0to3, PR0to3, MODE, RESET_N, BOOT_N, BSC	V _{IN1} V _{IN2}	-0.3 to DVDD5+0.3(≤6.0V) (Note1)	V
	PD0to3, PE0to6, PF0to4, PG0to1	V _{IN3}	-0.3 to AVDD5+0.3(≤6.0V)	
	PA4to5, PC0to1, PL0to1	V _{IN4}	-0.3 to 6.0	
Low level output current	Per pin PA0to3, PA6to7, PB0to7, PC2to6, PJ0to5, PK0to7, PL2to6, PM0to6, PN0to5, PP0to3, PR0to3	I _{OL}	5	mA
	Per Pin PA4to5, PC0to1, PL0to1	I _{OL4}	25	
	Total	ΣI _{OL}	50	
High level output current	Per pin PA0to7, PB0to7, PC0to6, PJ0to5, PK0to7, PL0to6, PM0to6, PN0to5, PP0to3, PR0to3	I _{OH}	-5	mA
	Total	ΣI _{OH}	-50	
Power consumption (Ta= 85°C)		PD	500	mW
Soldering temperature		T _{SOLDER}	260	°C
Storage temperature		T _{STG}	-55 to 125	°C
Operational temperature		T _{OPR}	-40 to 85	°C

Note1: DVDD5 is a generic name for DVDD5A, DVDD5B, and DVDD5C. DVDD5 and AVDD5 are used at the same voltage.

Note2: Absolute maximum ratings are limiting values of operating and environmental conditions which should not be exceeded under the worst possible conditions. The equipment manufacturer should design so that no Absolute maximum rating value is exceeded with respect to current, voltage, power consumption, temperature, etc. Exposure to conditions beyond those listed above may cause permanent damage to the device or affect device reliability, which could increase potential risks of personal injury due to IC blow up and/or burning.

7.2. DC Electrical Characteristics (1/2)

$$4.5V \leq DVDD5=AVDD5 \leq 5.5V$$

$$DVSS = AVSS=0V$$

$$T_a = -40 \text{ to } 85 \text{ } ^\circ\text{C}$$

Parameter	Symbol	Conditions	Min	Typ.	Max	Unit	
Power supply voltage	VDD	$f_{osc} = 6 \text{ to } 12\text{MHz}$ $f_{sys} = 1 \text{ to } 40\text{MHz}$ $f_s = 30 \text{ to } 34\text{kHz}$	4.5	-	5.5	V	
Low level input voltage	V_{IL1} V_{IL2}	PA0 to 3, PA6 to 7, PB1 to 7, PC2 to 6, PH0 to 3, PJ0 to 5, PK0 to 7, PL2 to 6, PM0 to 6, PN0 to 5, PP0 to 3, PR0 to 3, MODE, RESET_N, BOOT_N, BSC	-0.3	-	DVDD5×0.25	V	
	V_{IL3}	PD0 to 3, PE0 to 6, PF0 to 4, PG0 to 1			AVDD5×0.25		
	V_{IL4}	PA4 to 5, PC0 to 1, PL0 to 1			DVDD5×0.3		
High level input voltage	V_{IH1} V_{IH2}	PA0 to 3, PA6 to 7, PB1 to 7, PC2 to 6, PH0 to 3, PJ0 to 5, PK0 to 7, PL2 to 6, PM0 to 6, PN0 to 5, PP0 to 3, PR0 to 3, MODE, RESET_N, BOOT_N, BSC	DVDD5×0.75	-	DVDD5+0.3	V	
	V_{IH3}	PD0 to 3, PE0 to 6, PF0 to 4, PG0 to 1			AVDD5+0.3		
	V_{IH4}	PA4 to 5, PC0 to 1, PL0 to 1			DVDD5+0.3		
Low level output voltage	V_{OL1} V_{OL2}	PA0 to 7, PB0 to 7, PC0 to 6, PJ0 to 5, PK0 to 7, PL0 to 6, PM0 to 6, PN0 to 5, PP0 to 3, PR0 to 3	DVDD5=4.5V IOL=1.6mA	-	-	0.4	V
	V_{OL3}	PD0 to 3, PE0 to 6, PF0 to 4, PG0 to 1	AVDD5=4.5V IOL=1.6mA	-	-	0.4	
	V_{OL4}	PA4 to 5, PC0 to 1, PL0 to 1	DVDD5=4.5V IOL=8mA	-	-	1.0	
High level output voltage	V_{OH1} V_{OH2}	PA0 to 7, PB0 to 7, PC0 to 6, PJ0 to 5, PK0 to 7, PL0 to 6, PM0 to 6, PN0 to 5, PP0 to 3, PR0 to 3, PA4 to 5,	DVDD5=4.5V IOL=-1.6mA	DVDD5-0.4	-	-	V
	V_{OH3}	PD0 to 3, PE0 to 6, PF0 to 4, PG0 to 1	AVDD5=4.5V IOL=-1.6mA	AVDD5-0.4	-	-	

Note1: DVDD5 is a generic name for DVDD5A, DVDD5B, and DVDD5C.

Note2: Typ. value is in $T_a = 25 \text{ } ^\circ\text{C}$, DVDD5 = AVDDA5 = 5.0V, unless otherwise noted.

Note3: Apply same voltage to DVDD5 and AVDD5.

4.5V ≤ DVDD5=AVDD5 ≤ 5.5 V
DVSS=AVSS=0V
Ta= -40 to 85°C

Parameter		Symbol	Conditions	Min	Typ.	Max	Unit
Input leak current		I _{LI}	0.0V ≤ VIN ≤ DVDD5 0.0V ≤ VIN ≤ AVDD5	-5	0.05	5	μA
Output leak current		I _{LO}	0.2 ≤ VIN ≤ DVDD5-0.2 0.2 ≤ VIN ≤ AVDD5-0.2	-10	0.05	10	
Schmitt trigger Input width		V _{TH}	DVDD5=AVDD5=5.0V	-	1.0	-	V
Reset pull-up resistor		RRST		25	30	100	kΩ
Programmable pull-up/-down resistor		PKH	Pull-up	25	30	100	kΩ
			Pull-down	25	50	100	
Pin capacity (except power supply pin)		C _{IO}	fc =1MHz	-	-	10	pF
Low level output current	Per pin except below ports	I _{OL}	DVDD5=5V AVDD5=5V	-	-	2 (Note4)	mA
	Per pin PA4to5, PC0to1, PL0to1	I _{OL4}	DVDD5=5V	-	-	12 (Note4)	
	Total of PC0 to 6, PJ0 to 5, PK0 to 7, PN0 to 5, PP3, PR0 to 3	ΣI _{OL1}	DVDD5=5V	-	-	35 (Note5)	
	Total of PA0 to7, PB0 to7, PM0 to6, PL0 to6, PP0 to2	ΣI _{OL2}	DVDD5=5V	-	-	35 (Note5)	
	Total of PD0 to3, PE0 to6, PF0 to4, PG0 to1	ΣI _{OL3}	AVDD5=5V	-	-	20 (Note5)	
High level output current	per Pin	I _{OH}	DVDD5=5V AVDD5=5V	-2 (Note4)	-	-	mA
	Total of PC0 to 6, PJ0 to 5, PK0 to 7, PN0 to 5, PP3, PR0 to 3	ΣI _{OH1}	DVDD5=5V	-35 (Note5)	-	-	
	Total of PA0 to7, PB0 to7, PM0 to6, PL0 to6, PP0 to2	ΣI _{OH2}	DVDD5=5V	-35 (Note5)	-	-	
	Total of PD0 to3, PE0 to6, PF0 to4, PG0 to1	ΣI _{OH3}	AVDD5=5V	-20 (Note5)	-	-	

Note1: DVDD5 is a generic name for DVDD5A, DVDD5B, and DVDD5C.

Note2: Typ. value is in Ta = 25 °C, DVDD5 = AVDDA5 = 5.0V, unless otherwise noted

Note3: Apply same voltage to DVDD5 and AVDD5.

Note4: The current sum total of a terminal should not exceed the sum total of each group current.

Note5: The sum total of each group current should not exceed absolute maximum rating.

2.7V ≤ DVDD5=AVDD5 < 4.5V

DVSS = AVSS=0V

Ta=-40 to 85 °C

Parameter		Symbol	Conditions	Min	Typ.	Max	Unit
Power supply voltage	DVDD5A,DVDD5B,DVDD5C AVDD5	VDD	f _{osc} = 6 to 12MHz f _{sys} = 1 to 40MHz fs = 30 to 34kHz	2.7	-	4.5	V
Low level Input voltage	PA0 to 3,PA6 to 7,PB1 to 7, PC2 to 6,PH0 to 3,PJ0 to 5, PK0 to 7,PL2 to 6, PM0 to 6, PN0 to 5,PP0 to 3,PR0 to 3, MODE,RESET_N,BOOT_N, BSC	V _{IL1} V _{IL2}		-0.3	-	DVDD5×0.25	V
	PD0 to 3, PE0 to 6 PF0 to 4, PG0 to 1	V _{IL3}	AVDD5×0.25				
	PA4 to 5, PC0 to 1, PL0 to 1	V _{IL4}	DVDD5×0.3				
High level Input voltage	PA0 to 3,PA6 to 7,PB1 to 7, PC2 to 6, PH0 to 3,PJ0 to 5, PK0 to 7,PL2 to 6, PM0 to 6, PN0 to 5,PP0 to 3,PR0 to 3, MODE,RESET_N,BOOT_N, BSC	V _{IH1} V _{IH2}		DVDD5×0.75	-	DVDD5+0.3	V
	PD0 to 3, PE0 to 6, PF0 to 4, PG0 to 1	V _{IH3}	AVDD5×0.75			AVDD5+0.3	
	PA4 to 5, PC0 to 1, PL0 to 1	V _{IH4}	DVDD5×0.7			DVDD5+0.3	
Low level output voltage	PA0 to 7,PB0 to 7,PC0 to 6, PJ0 to 5, PK0 to 7,PL0 to 6, PM0 to 6 ,PN0 to 5, PP0 to 3, PR0 to 3	V _{OL1} V _{OL2}	DVDD5=2.7V IOL= 0.8mA	-	-	0.4	V
	PD0 to 3,PE0 to 6,PF0 to 4, PG0 to 1	V _{OL3}	AVDD5=2.7V IOL= 0.8mA	-	-	0.4	
	PA4 to 5,PC0 to 1, PL0 to 1	V _{OL4}	DVDD5=2.7V IOL= 4mA	-	-	1.0	
High level output voltage	PA0 to 7,PB0 to 7,PC0 to 6, PJ0 to 5,PK0 to 7,PL0 to 6, PM0 to 6,PN0 to 5, PP0 to 3, PR0 to 3, PA4 to 5,	V _{OH1} V _{OH2}	DVDD5=2.7V IOL= -0.8mA	DVDD5-0.4	-	-	V
	PD0 to 3, PE0 to 6,PF0 to 4, PG0 to 1	V _{OH3}	AVDD5=2.7V IOL= -0.8mA	AVDD5-0.4	-	-	

Note1: DVDD5 is a generic name for DVDD5A, DVDD5B, and DVDD5C.

Note2: Typ. value is in Ta = 25 °C, DVDD5 = AVDDA5 = 3.0V, unless otherwise noted.

Note3: Apply same voltage to DVDD5 and AVDD5.

2.7V ≤ DVDD5=AVDD5 < 4.5V
DVSS=AVSS=0V
Ta= -40 to 85°C

Parameter		Symbol	Conditions	Min	Typ.	Max	Unit
Input leak current		I _{LI}	0.0V ≤ VIN ≤ DVDD5 0.0V ≤ VIN ≤ AVDD5	-5	0.05	5	μA
Output leak current		I _{LO}	0.2 ≤ VIN ≤ DVDD5-0.2 0.2 ≤ VIN ≤ AVDD5-0.2	-10	0.05	10	
Schmitt trigger Input width		V _{TH}	DVDD5=AVDD5=3V	-	0.5	-	V
Reset pull-up resistor		RRST		25	100	200	kΩ
Programmable pull-up/-down resistor		PKH	Pull-up	25	100	200	
			Pull-down	25	100	200	
Pin capacity (except power supply pin)		C _{IO}	f _c =1MHz	-	-	10	pF
Low level output current	Per pin except below ports	I _{OL}	DVDD5=3V AVDD5=3V	-	-	1 (Note4)	mA
	Per pin PA4to5, PC0to1, PL0to1	I _{OL4}	DVDD5=3V	-	-	6 (Note4)	
	Total of PC0 to 6, PJ0 to 5, PK0 to 7, PN0 to 5, PP3, PR0 to 3	ΣI _{OL1}	DVDD5=3V	-	-	18 (Note5)	
	Total of PA0 to7, PB0 to7, PM0 to6, PL0 to6, PP0 to2	ΣI _{OL2}	DVDD5=3V	-	-	18 (Note5)	
	Total of PD0 to3, PE0 to6, PF0 to4, PG0 to1	ΣI _{OL3}	AVDD5=3V	-	-	10 (Note5)	
High level output current	per Pin	I _{OH}	DVDD5=3V AVDD5=3V	-1 (Note4)	-	-	mA
	Total of PC0 to 6, PJ0 to 5, PK0 to 7, PN0 to 5, PP3, PR0 to 3	ΣI _{OH1}	DVDD5=3V	-18 (Note5)	-	-	
	Total of PA0 to7, PB0 to7, PM0 to6, PL0 to6, PP0 to2	ΣI _{OH2}	DVDD5=3V	-18 (Note5)	-	-	
	Total of PD0 to3, PE0 to6, PF0 to4, PG0 to1	ΣI _{OH3}	AVDD5=3V	-10 (Note5)	-	-	

Note1: DVDD5 is a generic name for DVDD5A, DVDD5B, and DVDD5C.

Note2: Typ. value is in Ta = 25 °C, DVDD5 = AVDD5 = 3.0V, unless otherwise noted.

Note3: Apply same voltage to DVDD5 and AVDD5.

Note4: The current sum total of a terminal should not exceed the sum total of each group current.

Note5: The sum total of each group current should not exceed absolute maximum rating.

7.3. DC Electrical Characteristics (2/2)

Ta = -40 to 85°C

Parameter	Symbol	Conditions				Min	Typ. (Note2)	Max	Unit
		Supply voltage	High-speed oscillator	Low-speed oscillator	Operating condition				
Normal	I _{DD}	DVDD5= AVDD5= 5.5V	Refer to the table 7.2 and 7.3 for detail			-	9.5	12.5	mA
IDLE			Oscillation	Oscillation	Refer to the table 7.2 and 7.3 for detail	-	1.2	3.7	
STOP1			Stop	Oscillation		-	140	1900	μA
STOP2				Stop		-	13	100	
					-	12	100		

Note1: DVDD5 is a generic name for DVDD5A, DVDD5B, and DVDD5C.

Note2: Typ. value is in Ta = 25 °C, DVDD5 = AVDDA5 = 5.0V, unless otherwise noted.

Note3: Apply same voltage to DVDD5 and AVDD5.

Note4: Input pin is fixed level, Output pin is open.

Table 7.2 IDD measurement condition (Pin setting, Oscillation Circuit)

		NORMAL	IDLE	STOP1	STOP2	
					LOSC run	LOSC stop
Pin setting	DVDD5= AVDD5=	5.0V(Typ.), 5.5V(max)				
	X1,X2	Oscillator connected (10MHz)				
	XT1,XT2	Oscillator connected(32.768kHz)				
	Input pins	Fixed				
	Output pins	Open				
Operation condition (Oscillation Circuit)	System clock (fsys)	40MHz	Stop			
	External High-speed frequency oscillator (EHOSC)	Oscillation	Stop			
	Internal High-speed frequency oscillator (IHOSC)	Stop				
	PLL	run(4times)	Stop			
	Low-speed oscillator (ELOC)	Oscillation				Stop

Table 7.3 IDD measurement condition (CPU, Peripheral)

Peripheral	unit number	NORMAL	IDLE	STOP1	STOP2
				LOSC oscillation	LOSC stop
CPU	1	Run (Dhrystone Ver.2.1)		Stop	
DMAC	1	(Request from UARTch0 TX, destination: RAM)		Stop	
ADC	1	Run (1.5 μ s, Repeated conversion)		Stop	
DAC	2	Run		Stop	
T32A	6	All Ch: Run		Stop	
PMD+	1	Run		Stop	
A-ENC	1	Run		Stop	
RTC	1		Run		
SIWDT	1	Run		Stop	
UART	3	All ch: UART, Transmission(2.5Mbps)		Stop	
I ² C	3			Stop	
TSPI	2	Ch0, Ch1: Transmission(20MHz)		Stop	
RMC	1	Run		Stop	
LVD	1			Stop	
OFD	1			Stop	
Input Output Port	-	Run		Stop	

f_{sys}=40MHz

T_a=-40 to 85°C

Item	Symbol	Condition	Min	Typ.	Max	Unit
Current consumption (ADC,DAC run)	I _{AVDD}	AVDD=5.0V	-	3.3	4	mA
		AVDD=3.0V	-	2	3.2	

7.4. 12-bit AD Converter Characteristics

DVDD5=AVDD5=2.7V to 5.5V

DVSS=AVSS=0V

Ta= -40 to 85°C

Parameter	Symbol	Conditions	Min	Typ.	Max	Unit
Analog reference voltage (+)	AVDD5 (VREFH)		AVDD5-0.3	-	AVDD5+0.3	V
Analog input voltage	VAIN		AVSS	-	AVDD5 (VREFH)	V
Integral nonlinearity error (INL)	-	4.5 ≤ AVDD5 ≤ 5.5 AIN load resistor = 600 Ω AIN load capacity ≥ 0.1 μF Conversion time = 1.5 μs	-3.5	-	3.5	LSB
Differential nonlinearity error (DNL)			-2	-	2.5	
Zero-scale error			-1.5	-	5	
Full-scale error			-5	-	6	
Total errors			-6	-	6	
Integral nonlinearity error (INL)	-	2.7 ≤ AVDD5 < 4.5 AIN load resistor = 600 Ω AIN load capacity ≥ 0.1 μF Conversion time = 2.95 μs	-4	-	4	LSB
Differential nonlinearity error (DNL)			-2	-	4	
Zero-scale error			-3	-	6.5	
Full-scale error			-6	-	7.5	
Total errors			-7.5	-	7.5	
Stable time	t _{sta}	After [ADMOD0]<DACON>= 1 is set.	3	-	-	μs
Conversion time	t _{conv}	4.5V ≤ AVDD5 ≤ 5.5V SCLK=40MHz (Note3)	1.5	-	16.3	
		2.7V ≤ AVDD5 < 4.5V SCLK=40MHz (Note3)	2.95	-	16.65	

Note1: 1LSB = (AVDD5(VREFH) - AVSS(VREFL)) / 4096 [V]

Note2: This is the characteristic in case only AD converter is operation

Note3: For detail of setting, refer to "Analog to Digital Converter" of the reference manual.

DVDD5=AVDD5=2.7V to 5.5V

DVSS=AVSS=0V

Ta= -40 to 85°C

Parameter	Conditions	Min	Typ.	Max	Unit
Reference power	ch18 selected	1.1	-	1.3	V

Note: DVDD5 is a generic name for DVDD5A, DVDD5B, and DVDD5C.

7.5. 8-bit DA Converter Characteristics

DVDD5=AVDD5=2.7V to 5.5V

DVSS=AVSS=0V

Ta= -40 to 85°C

Parameter	Symbol	Conditions	Min	Typ.	Max	Unit
Analog reference voltage (+)	AVDD5 (VREFH)		AVDD5-0.3	-	AVDD5+0.3	V
Integral nonlinearity error (INL)	-	4.5V ≤ AVDD5 ≤ 5.5V Rload = 10MΩ	-1	-	+1	LSB
Differential nonlinearity error (DNL)			-1	-	+1	
Total errors			-1	-	+1	
Integral nonlinearity error (INL)	-	2.7V ≤ AVDD5 < 4.5V Rload = 10MΩ	-2	-	+2	LSB
Differential nonlinearity error (DNL)			-1	-	+1	
Total errors			-2	-	+2	
Stable time	t _{sta}	Cload = 20pF	4.5	-	-	μs

Note1; DVDD5 is a generic name for DVDD5A, DVDD5B, and DVDD5C.

Note2: Typ. value is in Ta = 25 °C, DVDD5 = AVDDA5 = 5V, unless otherwise noted.

Note3: 1LSB = (AVDD5(VREFH) - AVSS(VREFL)) / 256 [V]

Note4: This is the characteristic in case only DA converter is operating.

7.6. Characteristics of Internal processing at RESET

DVSS=AVSS=0V
Ta= -40to 85°C

Parameter	Symbol	Conditions	Min	Typ.	Max	Unit
Internal Initialized time	t _{INIT}	Power-On	-	-	2.15	ms
		STOP2 Release by RESET with RESET_N	-	-	1.8	
		STOP2 Release by Interrupt	-	-	1.55	
Internal processing time for Reset	t _{IRST}		0.16	-	0.2	
Waiting time till CPU running	t _{CPUWT}	Cold Reset	12	-	15	μs
		Warm Reset	55	-	90	
Power-on rising gradient	V _{PON}		0.01	-	100	mV/μs

7.7. Characteristics of Power-on Reset

DVSS=AVSS=0V
Ta= -40 to 85°C

Parameter	Symbol	Conditions	Min	Typ.	Max	Unit
Detection voltage	V _{PREL}	Power-up	2.25	2.4	2.55	V
	V _{PDET}	Power-down	2.2	2.35	2.5	
Detection pulse width	T _{PDET}		200	-	-	μs

7.8. Characteristics of Voltage Detection Circuit

DVDD5=AVDD5=2.7V to 5.5V

DVSS=AVSS=0V

Ta= -40 to 85°C

Parameter	Symbol	Conditions	Min	Typ.	Max	Unit	
Detection voltage	V _{LVL0}	Power-up	2.55	2.65	2.75	V	
		Power-down	2.5	2.6	2.7		
	V _{LVL1}	Power-up	2.65	2.75	2.85	V	
		Power-down	2.6	2.7	2.8		
	V _{LVL2}	Power-up	2.75	2.85	2.95	V	
		Power-down	2.7	2.8	2.9		
	V _{LVL3}	Power-up	2.85	2.95	3.05	V	
		Power-down	2.8	2.9	3.0		
	V _{LVL4}	Power-up	3.75	3.85	3.95	V	
		Power-down	3.7	3.8	3.9		
	V _{LVL5}	Power-up	3.95	4.05	4.15	V	
		Power-down	3.9	4.0	4.1		
	V _{LVL6}	Power-up	4.15	4.25	4.35	V	
		Power-down	4.1	4.2	4.3		
	V _{LVL7}	Power-up	4.35	4.45	4.55	V	
		Power-down	4.3	4.4	4.5		
	Detection response time	t _{VDDT1}	Power-down	-	50	200	μs
	Detection Release time	t _{VDDT2}	Power-up	-	250	-	
Setup time	t _{LVDEN}		-	-	100		
Detection Minimum pulse width	t _{LVDPW}		200	-	-		

7.9. AC Electrical Characteristics

7.9.1. Serial Peripheral Interface (TSPI)

7.9.1.1. AC Measurement Conditions

The AC characteristics are the result under the measurement conditions below:

- DVDD5=AVDD5=2.7V to 5.5V
- Ta = -40 to 85°C
- Output level: High = $0.8 \times DVDD5$, Low = $0.2 \times DVDD5$
- Input level: High = $0.75 \times DVDD5$, Low = $0.25 \times DVDD5$
- Load capacity: CL = 30pF

Note: DVDD5 is a generic name for DVDD5A, DVDD5B, and DVDD5C.

7.9.1.2. AC Electrical Characteristics

"T" indicates an operation clock cycle of the TSPI. This operation clock has the same cycle of the system clock (fsys). This cycle depends on the clock gear setting.

The number of cycles can be 1 to 16. It is specified with TSPIxSCK. The value of k1 is specified with [TSPIxFMTR0]<CSSCKDL[3:0]>; the value of k2 is specified with [TSPIxFMTR0]<SCKCSDL[3:0]>. These values are 1 to 16.

(1) Master mode

4.5V ≤ DVDD5=AVDD5 ≤ 5.5V

Parameter	Symbol	Calculation		fsys = 40MHz k1=k2=1		Unit
		Min	Max	Min	Max	
TSPIxSCK output frequency	f _{CYC}	-	20	-	20	MHz
TSPIxSCK output cycle	t _{CYC}	50	-	50	-	ns
TSPIxSCK low level output pulse width	t _{WL}	(t _{CYC} /2) - 13	-	12	-	
TSPIxSCK high level output pulse width	t _{WH}	(t _{CYC} /2) - 13	-	12	-	
TSPIxCSn output ← TSPIxSCK rise/fall time	t _{CSU}	(t _{CYC} × k1) - 20	(t _{CYC} × k1) + 15	30	65	
TSPIxSCK rise/fall time → TSPIxCSn hold time	t _{CHD}	(t _{CYC} × (k2 + 0.5)) - 20	-	55	-	
TSPIxRXD Input ← TSPIxSCK rise/fall time	t _{DSU}	35 - T(Notes)	-	10	-	
TSPIxSCK rise/fall time → TSPIxRXD hold time	t _{DHD}	T (Notes)	-	25	-	
TSPIxSCK rise/fall time → TSPIxTXD delay time	t _{ODLY1}	-18	-	-18	-	
TSPIxSCK rise/fall time → TSPIxTXD delay time	t _{ODLY2}	-	16	-	16	
TSPIxCSIN fall → TSPIxTXD delay time	t _{ODLY3}	(t _{CYC} × (k1 - 0.5)) - 25	(t _{CYC} × (k1 - 0.5)) + 17	0	42	

Note: In this case [TSPIxCR]<RXDLY>=0

2.7V ≤ DVDD5=AVDD5 < 4.5V
for TSPi1, TSPi2, TSPi3

Parameter	Symbol	Calculation		fsys = 40MHz k1=k2=1		Unit
		Min	Max	Min	Max	
TSPiXSCK output frequency	f _{CYC}	-	20	-	20	MHz
TSPiXSCK output cycle	t _{CYC}	50	-	50	-	ns
TSPiXSCK low level output pulse width	t _{WL}	(t _{CYC} /2) - 16	-	9	-	
TSPiXSCK high level output pulse width	t _{WH}	(t _{CYC} /2) - 16	-	9	-	
TSPiXCSn output ← TSPiXSCK rise/fall time	t _{CSU}	(t _{CYC} × k1) - 20	(t _{CYC} × k1) + 20	30	70	
TSPiXSCK rise/fall time → TSPiXCSn hold time	t _{CHD}	(t _{CYC} × (k2 + 0.5)) - 20	-	55	-	
TSPiXRxD Input ← TSPiXSCK rise/fall time	t _{DSU}	46 - T(Notes)	-	21	-	
TSPiXSCK rise/fall time → TSPiXRxD hold time	t _{DHD}	T (Notes)	-	25	-	
TSPiXSCK rise/fall time → TSPiXTxD delay time	t _{ODLY1}	-24	-	-24	-	
TSPiXSCK rise/fall time → TSPiXTxD delay time	t _{ODLY2}	-	21	-	21	
TSPiXCSIN fall → TSPiXTxD delay time	t _{ODLY3}	(t _{CYC} × (k1 - 0.5)) - 25	(t _{CYC} × (k1 - 0.5)) + 21	0	46	

Note: In this case [TSPiXCR2] < RXDLY > = 0

2.7V ≤ DVDD5=AVDD5 < 4.5V
for TSPi0

Parameter	Symbol	Calculation		fsys = 40MHz k1=k2=1		Unit
		Min	Max	Min	Max	
TSPiXSCK output frequency	f _{CYC}	-	20	-	20	MHz
TSPiXSCK output cycle	t _{CYC}	50	-	50	-	ns
TSPiXSCK low level output pulse width	t _{WL}	(t _{CYC} /2) - 16	-	9	-	
TSPiXSCK high level output pulse width	t _{WH}	(t _{CYC} /2) - 16	-	9	-	
TSPiXCSn output ← TSPiXSCK rise/fall time	t _{CSU}	(t _{CYC} × k1) - 34	(t _{CYC} × k1) + 20	16	70	
TSPiXSCK rise/fall time → TSPiXCSn hold time	t _{CHD}	(t _{CYC} × (k2 + 0.5)) - 20	-	55	-	
TSPiXRxD Input ← TSPiXSCK rise/fall time	t _{DSU}	46 - T(Notes)	-	21	-	
TSPiXSCK rise/fall time → TSPiXRxD hold time	t _{DHD}	T (Notes)	-	25	-	
TSPiXSCK rise/fall time → TSPiXTxD delay time	t _{ODLY1}	-24	-	-24	-	
TSPiXSCK rise/fall time → TSPiXTxD delay time	t _{ODLY2}	-	21	-	21	
TSPiXCSIN fall → TSPiXTxD delay time	t _{ODLY3}	(t _{CYC} × (k1 - 0.5)) - 39	(t _{CYC} × (k1 - 0.5)) + 24	-14	49	

Note: In this case [TSPiXCR2] < RXDLY > = 0

(2) Slave mode

4.5V ≤ DVDD5=AVDD5 ≤ 5.5V

Parameter	Symbol	Calculation		fsys = 40MHz k1=1		Unit
		Min	Max	Min	Max	
TSPIxSCK Input frequency	f _{CYC}	-	10	-	10	MHz
TSPIxSCK Input cycle	t _{CYC}	100	-	100	-	ns
TSPIxSCK low level Input pulse width	t _{WL}	t _{CYC} / 2 - 13	-	37	-	
TSPIxSCK high level Input pulse width	t _{WH}	t _{CYC} / 2 - 13	-	37	-	
TSPIxCSIN Input ← TSPIxSCK rise/fall time	t _{CSU1}	(t _{CYC} × (k1 + 0.5)) +20	-	170	-	
TSPIxCSIN Input ← TSPIxSCK rise/fall time	t _{CSU2}	(t _{CYC} × k1) - 20	-	80	-	
TSPIxSCK rise/fall time → TSPIxCSIN hold time	t _{CHD}	5	-	5	-	
TSPIxRXD Input ← TSPIxSCK rise/fall time	t _{DSU}	7	-	7	-	
TSPIxSCK rise/fall → TSPIxRXD hold time	t _{DHD}	10	-	10	-	
TSPIxSCK rise/fall → TSPIxTXD delay time	t _{ODLY1}	0	-	0	-	
TSPIxSCK rise/fall → TSPIxTXD delay time	t _{ODLY2}	-	36	-	36	
TSPIxCSIN fall → TSPIxTXD delay time	t _{ODLY3}	-	(t _{CYC} × (k1 - 0.5)) + 5	-	55	
TSPIxCSIN high level input pulse width	t _{WDIS}	T × 2 + 20	-	70	-	

2.7V ≤ DVDD5=AVDD5 < 4.5V

Parameter	Symbol	Calculation		fsys = 40MHz k1=1		Unit
		Min	Max	Min	Max	
TSPIxSCK Input frequency	f _{CYC}	-	10	-	10	MHz
TSPIxSCK Input cycle	t _{CYC}	100	-	100	-	ns
TSPIxSCK low level Input pulse width	t _{WL}	t _{CYC} / 2 - 13	-	37	-	
TSPIxSCK high level Input pulse width	t _{WH}	t _{CYC} / 2 - 13	-	37	-	
TSPIxCSIN Input ← TSPIxSCK rise/fall time	t _{CSU1}	(t _{CYC} × (k1 + 0.5)) +20	-	170	-	
TSPIxCSIN Input ← TSPIxSCK rise/fall time	t _{CSU2}	(t _{CYC} × k1) - 20	-	80	-	
TSPIxSCK rise/fall time → TSPIxCSIN hold time	t _{CHD}	5	-	5	-	
TSPIxRXD Input ← TSPIxSCK rise/fall time	t _{DSU}	7	-	7	-	
TSPIxSCK rise/fall → TSPIxRXD hold time	t _{DHD}	10	-	10	-	
TSPIxSCK rise/fall → TSPIxTXD delay time	t _{ODLY1}	0	-	0	-	
TSPIxSCK rise/fall → TSPIxTXD delay time	t _{ODLY2}	-	48	-	48	
TSPIxCSIN fall → TSPIxTXD delay time	t _{ODLY3}	-	(t _{CYC} × (k1 - 0.5)) + 5	-	55	
TSPIxCSIN high level input pulse width	t _{WDIS}	T × 2 + 20	-	70	-	

(1) 1st clock edge sampling (Master)

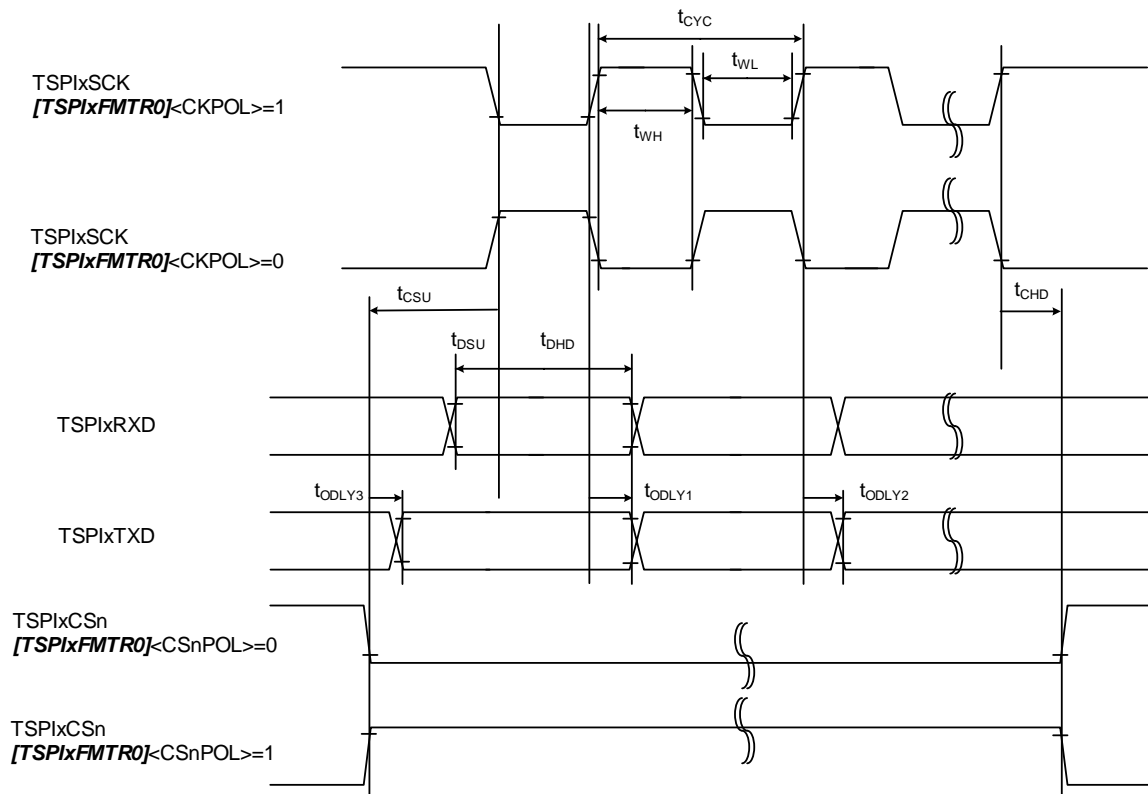

Figure 7.1 1st clock edge sampling (Master)

(2) 2nd clock edge sampling (Master)

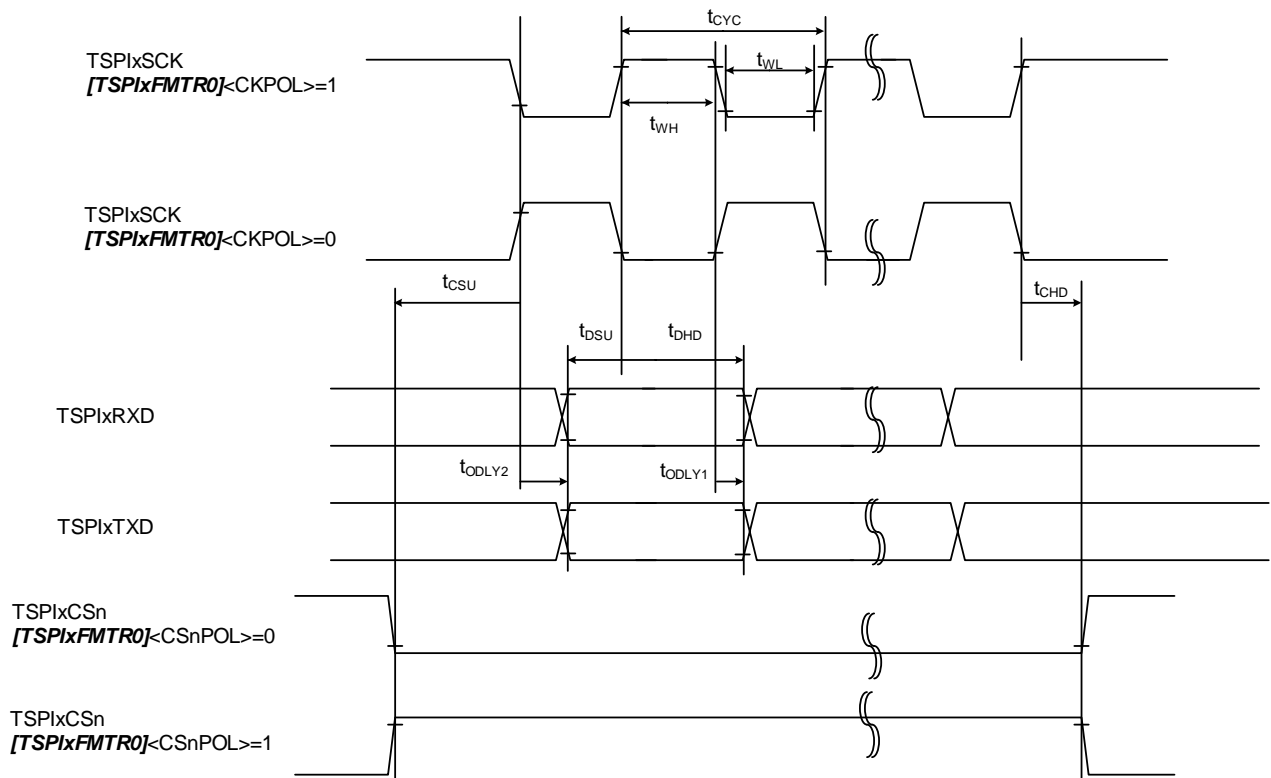

Figure 7.2 2nd clock edge sampling (Master)

(3) 2nd clock edge sampling (slave)

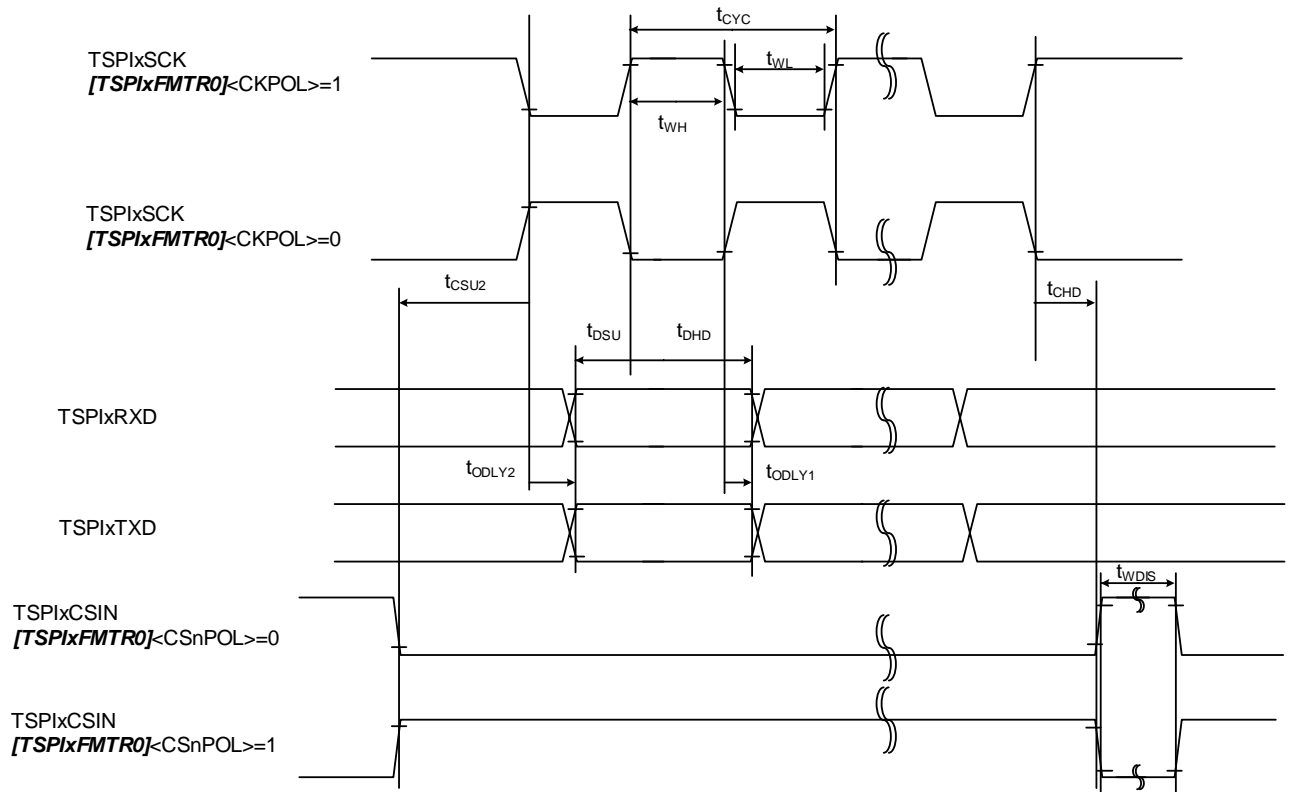

Figure 7.3 2nd clock edge sampling (Slave)

7.9.2. I²C Interface (I²C)

7.9.2.1. AC Measurement Conditions

The AC characteristics are the result under the measurement conditions below:

- DVDD5=AVDD5=2.7v to 5.5V
- Ta = -40 to 85°C
- Output level: Low = 0.4V
- Input level: High = 0.7 × DVDD5, Low = 0.3 × DVDD5
- Load capacity: CL = 30pF

Note: DVDD5 is a generic name for DVDD5A, DVDD5B, and DVDD5C.

7.9.2.2. AC Electrical Characteristics

T indicates the Operation clock cycle of I²C. The I²C operation clock is as same as the system clock (fsys) cycle. It is depend on the Clock Gear setup.

The value of n is the SCL output clock frequency specified with $[I2CxCR]<SCK>$. The value of p is the prescaler dividing ratio specified with $[I2CxPRS]<PRsCK>$.

Parameter	Symbol	Standard mode		Fast mode		Fast mode+		Unit
		Min	Max	Min	Max	Min	Max	
SCL clock frequency	f _{SCL}	0	100	0	400	0	1000	kHz
Start condition hold time	t _{HD, STA}	4.0	-	0.6	-	0.26	-	μs
SCL clock Low width (Input) (Note1)	t _{LOW}	4.7	-	1.3	-	0.5	-	
SCL clock High width (Input) (Note2)	t _{HIGH}	4.0	-	0.6	-	0.26	-	
Re-start condition setup time (Note5)	t _{SU, STA}	4.7	-	0.6	-	0.26	-	
Data hold time (Input) (Note3, 4)	t _{HD, DAT}	0	-	0	-	0	-	ns
Data setup time	t _{SU, DAT}	250	-	100	-	50	-	μs
Stop condition setup time	t _{SU, STO}	4.0	-	0.6	-	0.26	-	
Bus free time between stop condition and start condition (Note5)	t _{BUF}	4.7	-	1.3	-	0.5	-	μs

Note1: SCL clock low level width (output): $p \times (2^{n+1}+10)/T$ ($[I2CxOP]<NFSEL>=0$)

Note2: SCL clock high level width(output): $p \times (2^{n+1}+6)/T$ ($[I2CxOP]<NFSEL>=0$)

On I²C bus standard, the maximum speed of standard mode/fast mode/fast mode+ is 100kHz/400 kHz/1MHz respectively. Note that an internal SCL clock frequency is determined by the fsys and the calculation of Note1 and Note2 above-mentioned.

Note3: The data hold time (output) is equal to four cycles of the prescaler clock (Tprscck) started from the internal SCL.

Note4: On I²C bus standard, it is described that a data internal hold time should be set at least 300 ns to avoid unstable condition on the falling of the SCL when the SDA is input; however, this precaution is not supported in this MCU. Also, the edge slope control function for the SCL is not available. Therefore, when the customer designs the MCU, make sure to follow the data hold time (input) in the table above. Note that tr/td on the SCL/SDA should be included in the data hold time.

Note5: Depends on the software.

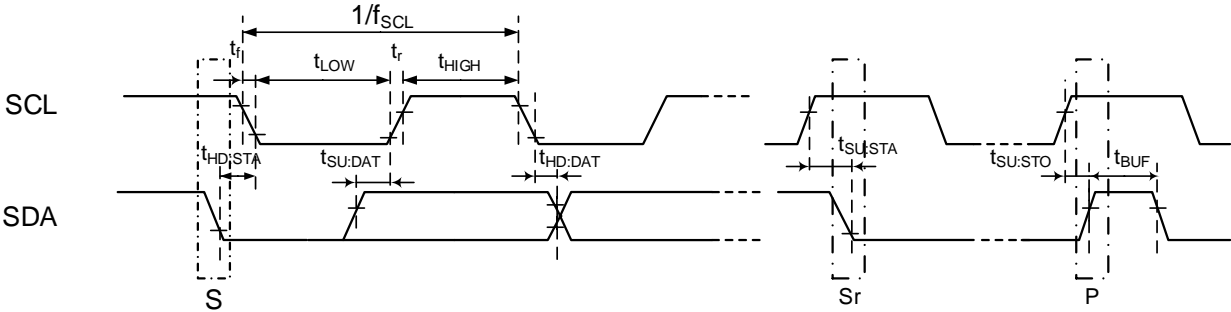

Figure 7.4 AC timing of I²C

7.9.3. 32-bit Timer Event Counter (T32A)

This section describes AC characteristics of T32AxINA0/A1, T32AxINB0/B1, and T32AxINC0/C1.

7.9.3.1. AC Measurement Conditions

The AC characteristics are the result under the measurement conditions below:

- DVDD5=AVDD5=2.7V to 5.5V
- Ta = -40 to 85°C
- Input level: High = $0.75 \times DVDD5$, Low = $0.25 \times DVDD5$
- Load capacity: CL = 30pF

Note: DVDD5 is a generic name for DVDD5A, DVDD5B, and DVDD5C.

7.9.3.2. AC Characteristics

"T" in the table below indicates the operation clock cycle of the T32A. The operation clock of the T32A is the same cycle as $\Phi T0$ clock. This cycle is depending on the Prescaler Clock setting.

- (1) Operation other than the pulse count

Parameter	Symbol	Calculation		$\Phi T0=40$ MHz		Unit
		Min	Max	Min	Max	
Low level pulse width	t _{VCKL}	2T + 20	-	70	-	ns
High level pulse width	t _{VCKH}	2T + 20	-	70	-	

- (2) At the pulse count

Parameter	Symbol	Calculation		$\Phi T0=40$ MHz In this case, NF=4		Unit
		Min	Max	Min	Max	
Pulse cycle	t _{DCYC}	1000	-	1000	-	ns
Low level pulse width	t _{PWL}	500	-	500	-	
High level pulse width	t _{PWH}	500	-	500	-	
Input setup	t _{ABS}	$(NF+1) \times T + 20$	-	145	-	
Input hold	t _{ABH}	$(NF+1) \times T + 20$	-	145	-	

NF Value is depend on the $[T32AxPLSCR]<NF[1:0]>$ setting as follows.

$[T32AxPLSCR]<NF[1:0]>$	NF Value of Formula
00	0
01	2
10	4
11	8

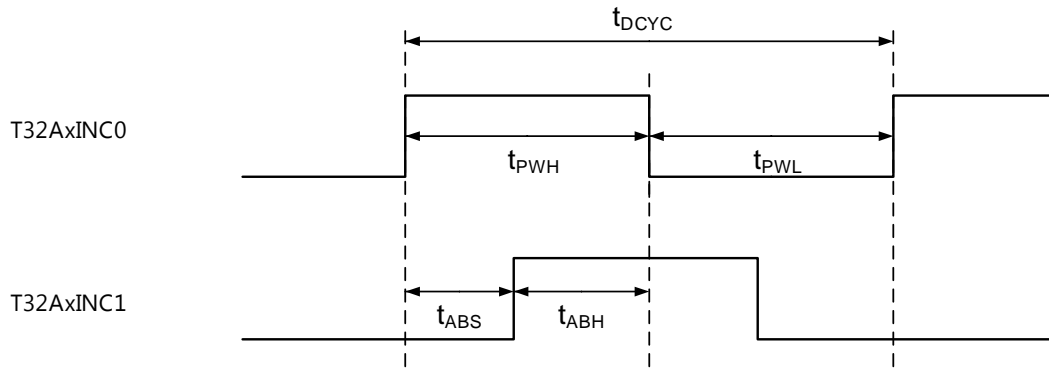

Figure 7.5 Count Pulse input

7.9.4. External Interrupt

7.9.4.1. AC Measurement Conditions

The AC characteristics are the result under the measurement conditions below:

- DVDD5=AVDD5=2.7V to 5.5V
- Ta = -40°C to 85°C
- Input level: High = $0.75 \times DVDD5$, Low = $0.25 \times DVDD5$
- Load capacity: CL = 30pF

Note: DVDD5 is a generic name for DVDD5A, DVDD5B, and DVDD5C.

7.9.4.2. AC Electrical Characteristics

"T" in the table below indicates the cycle of the system clock (fsys).

(1) NORMAL, IDLE mode

Parameter	Symbol	Calculation		fsys=40 MHz		Unit
		Min	Max	Min	Max	
Low level pulse width	t_{INTAL1}	T + 100	-	125	-	ns
High level pulse width	t_{INTAH1}	T + 100	-	125	-	

(2) STOP1, STOP2 mode

Parameter	Symbol	Calculation		fsys=40 MHz		Unit
		Min	Max	Min	Max	
Low level pulse width	t_{INTCL2}	125	-	125	-	ns
High level pulse width	t_{INTCH2}	125	-	125	-	

7.9.5. Trigger Input (TRGINx)

7.9.5.1. AC Measurement Conditions

The AC characteristics are the result under the measurement conditions below:

- DVDD5=AVDD5 = 2.7V to 5.5V
- Ta = -40°C to 85°C
- Input level: High = $0.75 \times DVDD5$, Low = $0.25 \times DVDD5$
- Load capacity: CL = 30pF

Note: DVDD5 is a generic name for DVDD5A, DVDD5B, and DVDD5C.

7.9.5.2. AC Electrical Characteristics

"T" in the table below indicates the cycle of the system clock (fsys).

Parameter	Symbol	Calculation		fsys=40 MHz		Unit
		Min	Max	Min	Max	
Low level pulse width	t _{ADL}	2T + 20	-	70	-	ns
High level pulse width	t _{ADH}	2T + 20	-	70	-	

7.9.6. Debug Communication

7.9.6.1. AC Measurement Conditions

The AC characteristics are the result under the measurement conditions below:

- DVDD5 = AVDD5 = 2.7V to 5.5V
- Ta = -40°C to 85°C
- Output level: High = 0.8 × DVDD5, Low = 0.2 × DVDD5
- Input level: High = 0.75 × DVDD5, Low = 0.25 × DVDD5
- Load capacity: CL = 30pF

Note: DVDD5 is a generic name for DVDD5A, DVDD5B, and DVDD5C.

7.9.6.2. SWD Interface

4.5V ≤ DVDD5=AVDD5 ≤ 5.5V

Parameter	Symbol	Min	Max	Unit
CLK cycle	t_{dck}	100	-	ns
Output data hold from on the rising edge of CLK	t_{d1}	4	-	
Output data valid from on the rising edge of CLK	t_{d2}	-	30	
Rising edge of CLK from input data valid	t_{ds}	20	-	
Input data hold from on the rising edge of CLK	t_{dh}	15	-	

2.7V ≤ DVDD5=AVDD5 < 4.5V

Parameter	Symbol	Min	Max	Unit
CLK cycle	t_{dck}	100	-	ns
Output data hold from on the rising edge of CLK	t_{d1}	4	-	
Output data valid from on the rising edge of CLK	t_{d2}	-	42	
Rising edge of CLK from input data valid	t_{ds}	20	-	
Input data hold from on the rising edge of CLK	t_{dh}	15	-	

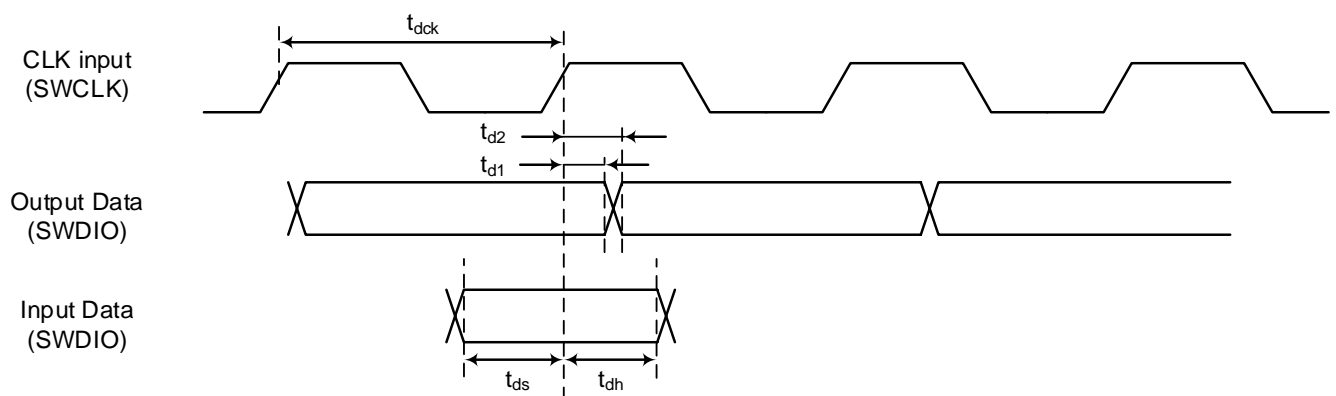

Figure 7.6 SWD waveform

7.9.6.3. JTAG Interface

4.5V ≤ DVDD5=AVDD5 ≤ 5.5V

Parameter	Symbol	Min	Max	Unit
CLK cycle	t_{dck}	100	-	ns
Output data hold from on the falling edge of CLK	t_{d3}	4	-	
Output data valid from on the falling edge of CLK	t_{d4}	-	33	
Rising edge of CLK from input data valid	t_{ds}	20	-	
Input data hold from on the rising edge of CLK	t_{dh}	15	-	

2.7V ≤ DVDD5=AVDD5 < 4.5V

Parameter	Symbol	Min	Max	Unit
CLK cycle	t_{dck}	100	-	ns
Output data hold from on the falling edge of CLK	t_{d3}	4	-	
Output data valid from on the falling edge of CLK	t_{d4}	-	45	
Rising edge of CLK from input data valid	t_{ds}	20	-	
Input data hold from on the rising edge of CLK	t_{dh}	15	-	

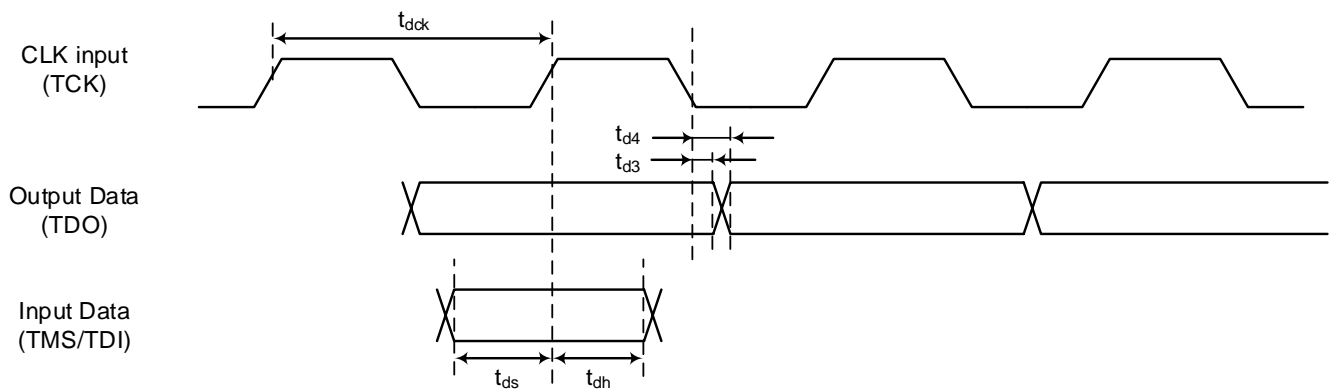

Figure 7.7 JTAG waveform

7.9.6.4. ETM Trace

4.5V ≤ DVDD5=AVDD5 ≤ 5.5V

Parameter	Symbol	Min	Max	Unit
TRACECLK cycle	t_{clk}	50	-	ns
Data valid from rising on TRACECLK	t_{setupr}	2	-	
TRACEDATA hold from on the rising edge of TRACECLK	t_{holdr}	1	-	
TRACEDATA valid from on the falling edge of TRACECLK	t_{setupf}	2	-	
TRACEDATA hold from on the falling edge of TRACECLK	t_{holdf}	1	-	

2.7V ≤ DVDD5=AVDD5 < 4.5V

Parameter	Symbol	Min	Max	Unit
TRACECLK cycle	t_{clk}	100	-	ns
Data valid from rising on TRACECLK	t_{setupr}	2	-	
TRACEDATA hold from on the rising edge of TRACECLK	t_{holdr}	1	-	
TRACEDATA valid from on the falling edge of TRACECLK	t_{setupf}	2	-	
TRACEDATA hold from on the falling edge of TRACECLK	t_{holdf}	1	-	

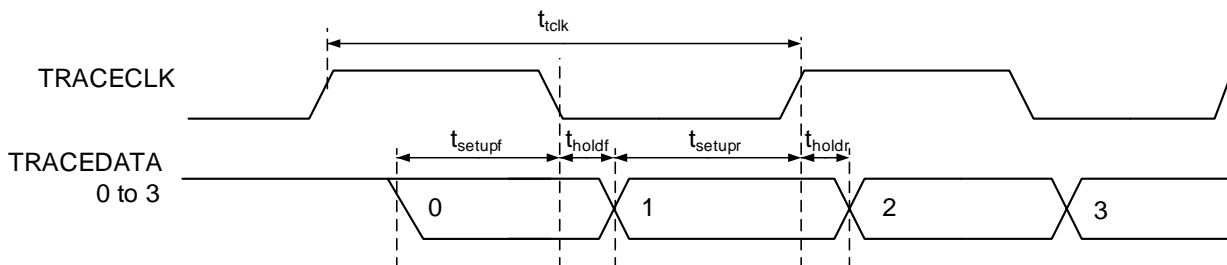

Figure 7.8 Trace signal waveform

7.9.7. SCOUT Pin

7.9.7.1. AC Measurement Conditions

The AC characteristics are the result under the measurement conditions below:

- DVDD5= AVDD5= 2.7V to 5.5V
- Ta = -40°C to 85°C
- Output level: High = $0.8 \times DVDD5$, Low = $0.2 \times DVDD5$
- Load capacity: CL = 30pF

Note: DVDD5 is a generic name for DVDD5A, DVDD5B, and DVDD5C.

7.9.7.2. AC Electrical Characteristics

"T" in the table indicates the cycle of the SCOUT output waveform.

$4.5V \leq DVDD5=AVDD5 \leq 5.5V$

Parameter	Symbol	Calculation		SCOUT = 20MHz		Unit
		Min	Max	Min	Max	
Low level pulse width	t _{SCL}	0.5T- 10	-	15	-	ns
High level pulse width	t _{SCH}	0.5T- 10	-	15	-	

$2.7V \leq DVDD5=AVDD5 < 4.5V$

Parameter	Symbol	Calculation		SCOUT = 20MHz		Unit
		Min	Max	Min	Max	
Low level pulse width	t _{SCL}	0.5T- 12	-	13	-	ns
High level pulse width	t _{SCH}	0.5T- 12	-	13	-	

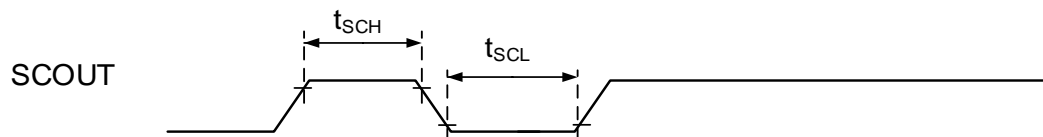

Figure 7.9 SCOUT wave output

7.9.8. Noise Filter Characteristics

Parameter	Condition	Min	Typ.	Max	Unit
Noise cancel width	DVDD5 = 2.7 to 5.5V Ta = -40 to 85°C	15	30	60	ns

7.9.9. External Clock Input

7.9.9.1. AC Measurement Conditions

The AC characteristics are the result under the measurement conditions below:

- DVDD5 = AVDD5 = 2.7V to 5.5V
- Ta = -40°C to 85°C
- Input level: High = $0.75 \times DVDD5$, Low = $0.25 \times DVDD5$
- Load capacity: CL = 30pF

Note: DVDD5 is a generic name for DVDD5A, DVDD5B, and DVDD5C.

7.9.9.2. AC Electrical Characteristics

Parameter	Symbol	Min	Typ.	Max	Unit
Clock frequency($1/t_{ehcin}$)	$f_{EHCLKIN}$	6	-	20	MHz
Clock duty	-	45	-	55	%
Clock rise time	t_r	-	-	10	ns
Clock fall time	t_f	-	-	10	ns

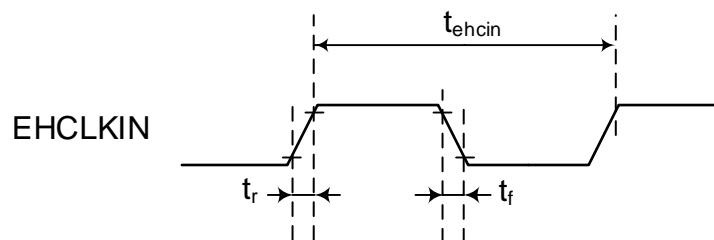

Figure 7.10 External clock input waveform

7.10. Flash Memory Characteristics

7.10.1. Code Flash

DVDD5=2.7V to 5.5V
Ta=-40 to 85°C

Parameter	Condition	Min	Typ.	Max	Unit
Endurance		-	-	10,000	cycles
Programming time	Word Program time	-	29.5	-	μs
Erase time	Page Erase time	1.1	-	4.3	ms
	Block Erase time	8.6	-	34	
	Area Erase time(Note2)	-	9.2	-	

Note1: DVDD5 is a generic name for DVDD5A, DVDD5B, and DVDD5C.

Note2: No block with effective protection.

7.10.2. Data Flash

DVDD5=2.7V to 5.5V
Ta=-40 to 85°C

Parameter	Condition	Min	Typ.	Max	Unit
Endurance		-	-	100,000	cycles
Programming time		-	64.7	-	μs
Erase time	Page Erase time	1	-	3.9	ms
	Block Erase time	15.4	-	62.1	
	Area Erase time(Note2)	-	9.2	-	

Note1: DVDD5 is a generic name for DVDD5A, DVDD5B, and DVDD5C.

Note2: No block with effective protection.

7.10.3. Chip Erase

DVDD5= 2.7V to 5.5V
Ta= -40 to 85°C

Parameter	Condition	Min	Typ.	Max	Unit
Chip Erase time	Erasing of Code Flash, Data Flash, Protect Bits(Code), Protect Bits(Data), User Information Area and Security bits	23.4	-	62.7	ms

Note1: DVDD5 is a generic name for DVDD5A, DVDD5B, and DVDD5C.

Note2: When Chip Erase command executes, no block with effective protection.

7.11. Regulator

Parameter	Condition	Min	Typ.	Max	Unit
Capacitance of REGOUT1 capacitor	DVDD5=2.7V to 5.5V Ta=-40 to 85°C	-	4.7	-	μF
Capacitance of REGOUT2 capacitor		-	4.7	-	

Note: DVDD5 is a generic name for DVDD5A, DVDD5B, and DVDD5C.

7.12. Oscillation Circuit

7.12.1. Internal Oscillator

DVDD5= 2.7V to 5.5V
Ta= -40 to 85°C

Parameter	Symbol	Condition	Min	Typ.	Max	Unit
Oscillation frequency	f _{IHOSC1}	Factory out, IC data (Note2)	-	10	-	MHz
	f _{IHOSC2}		-	10	-	

Note1: DVDD5 is a generic name for DVDD5A, DVDD5B, and DVDD5C.

Note2: Not included the influence depend on the variations after Factory shipping. Please execute oscillator adjustment by the trimming register, if trimming of IHOSC1 is required. However, IHOSC2 cannot execute trimming.

7.12.2. External Oscillator

DVDD5= 2.7V to 5.5V
Ta= -40 to 85°C

Parameter	Symbol	Condition	Min	Typ.	Max	Unit
Oscillation frequency	f _{EHOSC}		6	-	12	MHz
	f _{ELOSC}		30	-	34	kHz

Note1: DVDD5 is a generic name for DVDD5A, DVDD5B, and DVDD5C.

Note2: Please contact the oscillator vendor, regarding the matching data of the device and the oscillator.

7.12.3. Oscillation Circuit

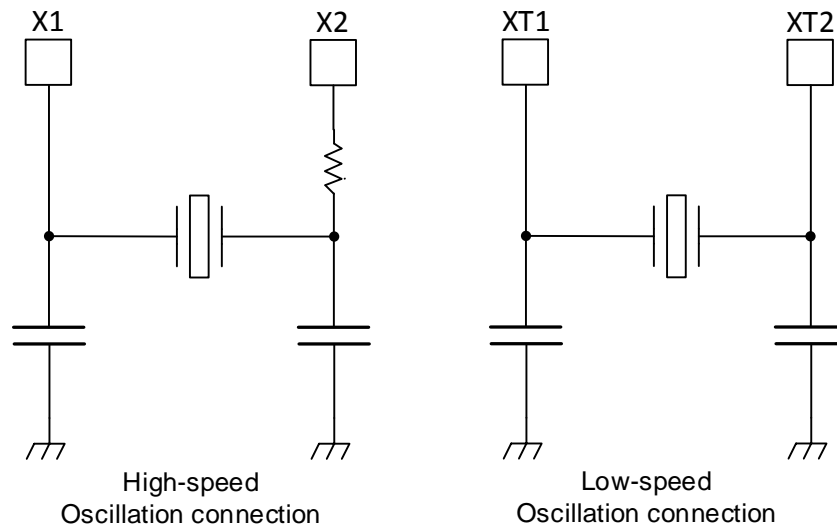

Figure 7.11 Oscillation circuit sample

To obtain a stable oscillation, load capacity and the position of the oscillator must be configured properly.

Since these factors are strongly affected by substrate patterns, please evaluate oscillation stability using the substrate you use.

This product has been evaluated by the oscillator vendor below. Please refer to this information when selecting external parts.

7.12.4. Ceramic Oscillator

This product has been evaluated by the ceramic oscillator by Murata Manufacturing Co., Ltd.

Please refer to the Murata Website for details.

7.12.5. Crystal Oscillator

This product has been evaluated by the crystal oscillator by KYOCERA Corporation.

Please refer to the KYOCERA Website for details.

7.12.6. Precautions for designing printed circuit board

Be sure to design printed circuit board patterns that connect a crystal unit with other oscillation elements so that the length of such patterns become shortest possible to prevent deterioration of characteristics due to stray capacitances and wiring inductance. For multi-layer circuit boards, it is important not to wire the ground and other signal patterns right beneath the oscillation circuit. For more information, please refer to the URL of the oscillator vendor.

8. Package Dimensions

8.1. LQFP100-P-1414-0.50H

Unit: mm

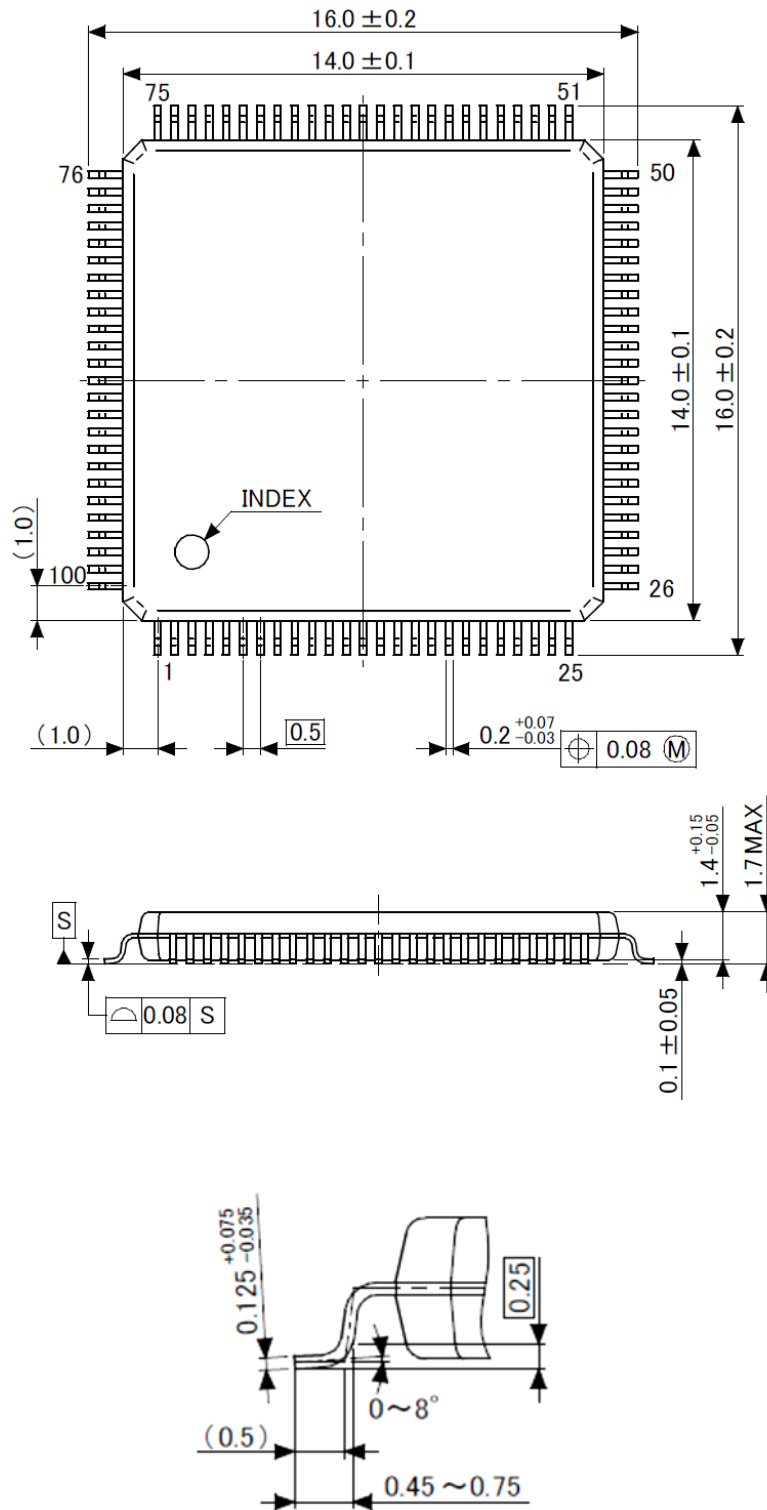

8.2. P-QFP100-1420-0.65-001

Unit: mm

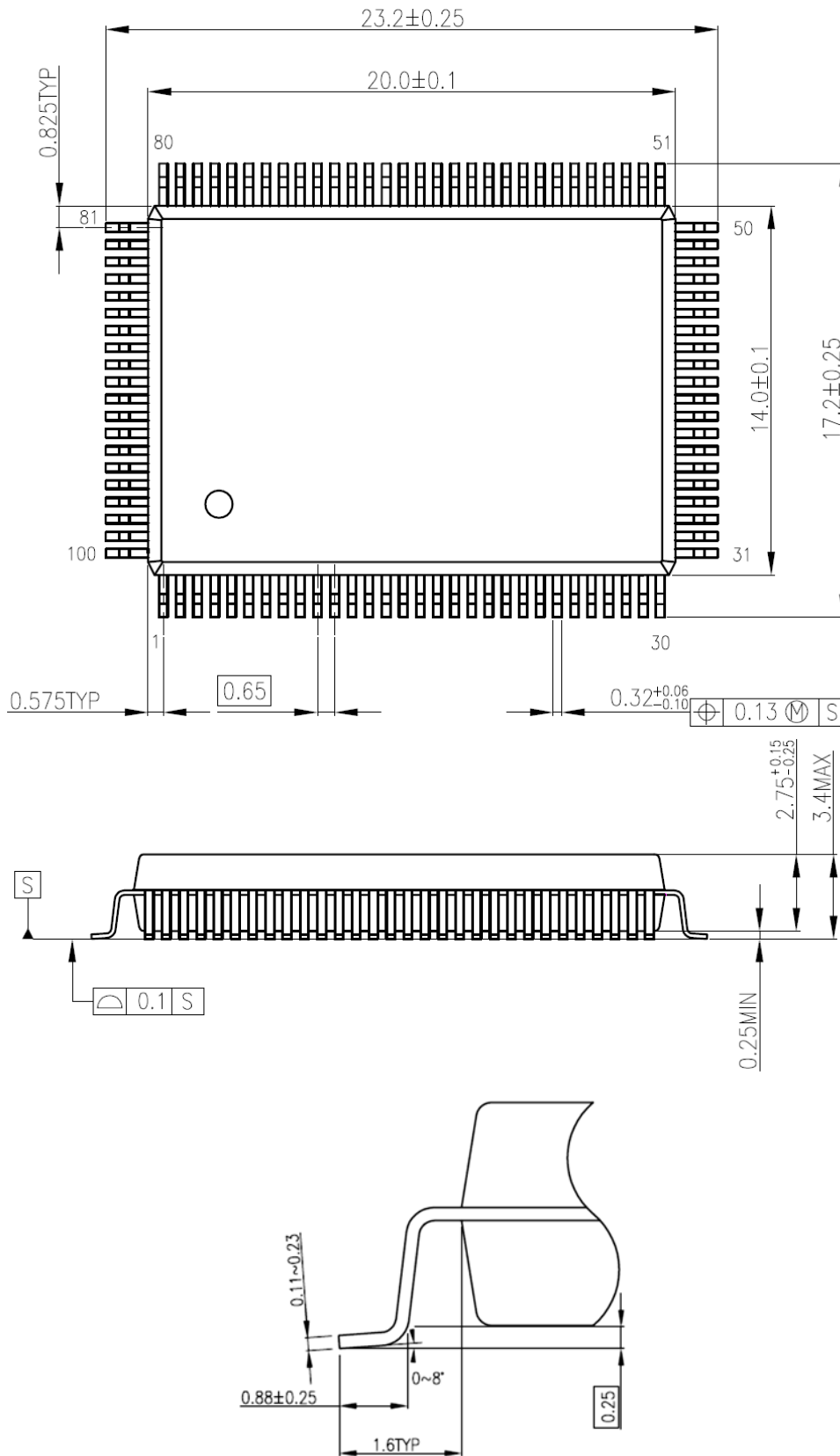

8.3. LQFP80-P-1212-0.50F

Unit: mm

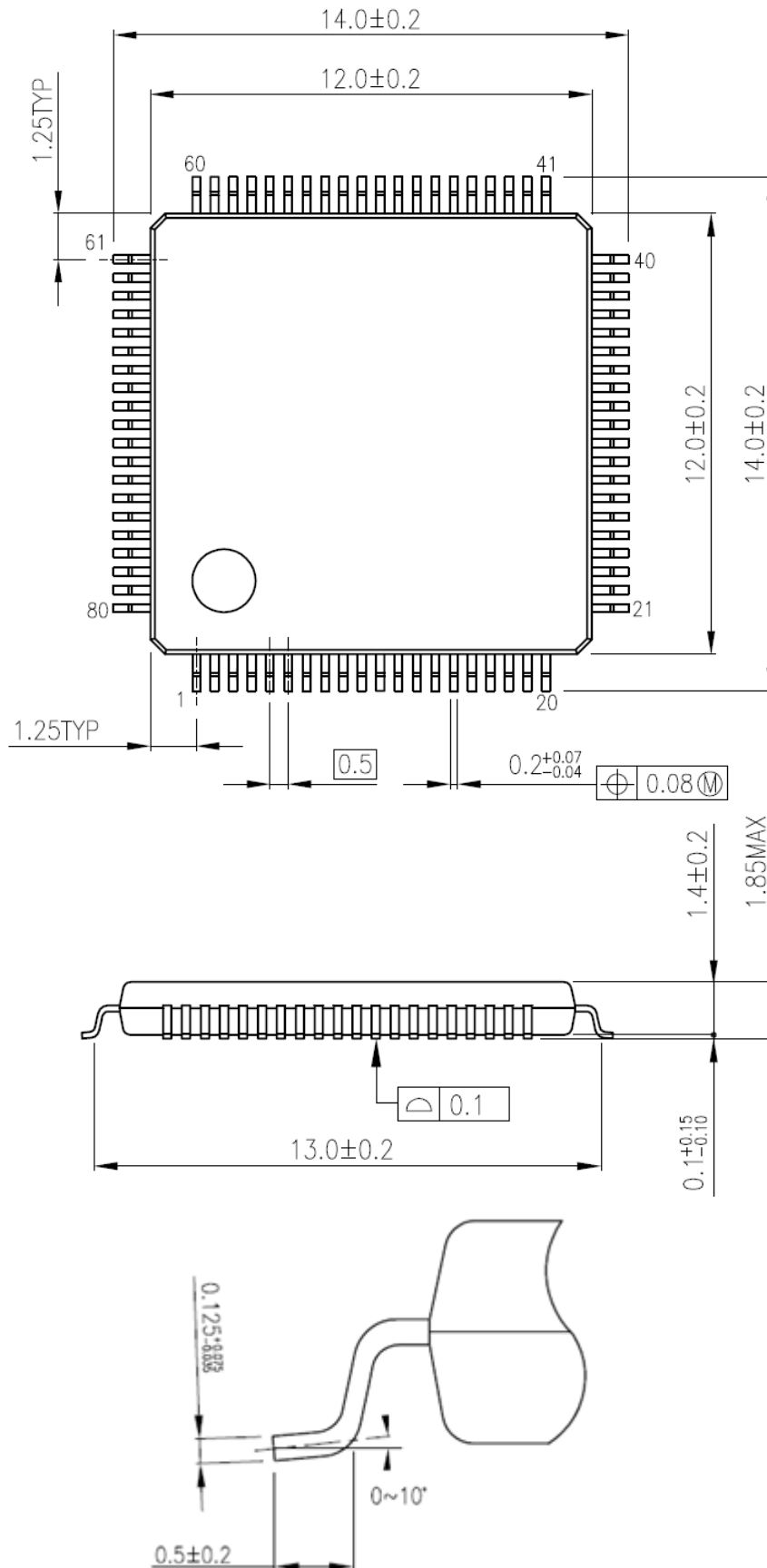

8.4. P-LQFP80-1414-0.65-001

Unit: mm

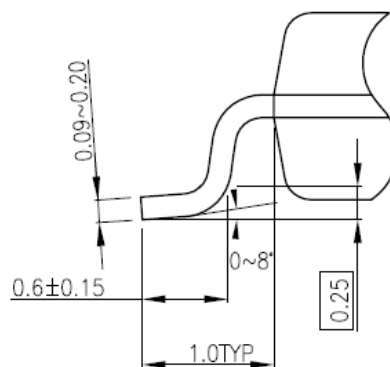
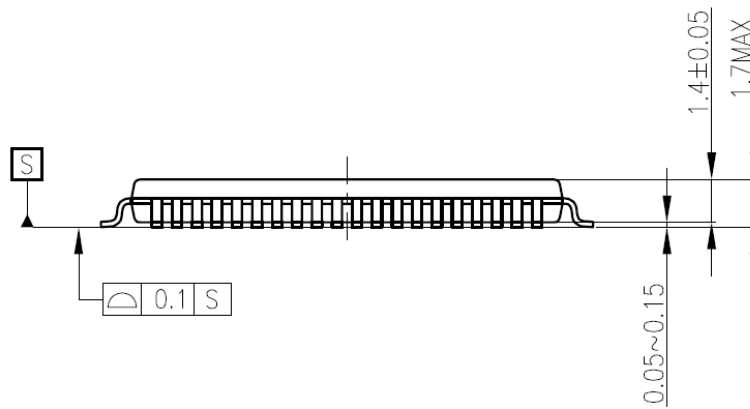
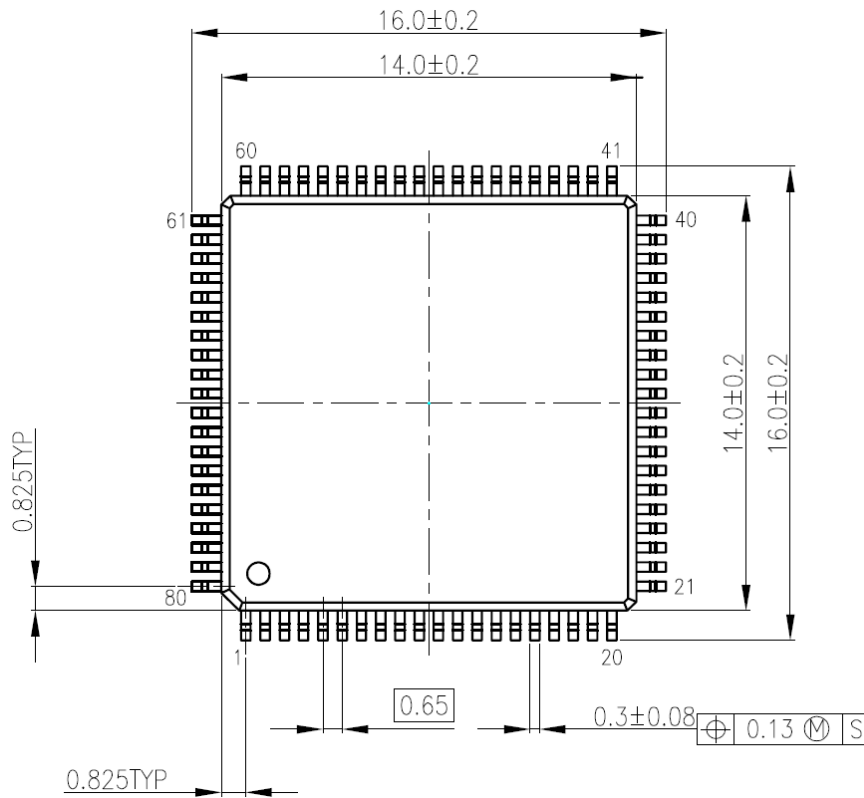

8.6. P-LQFP64-1414-0.80-002

Unit: mm

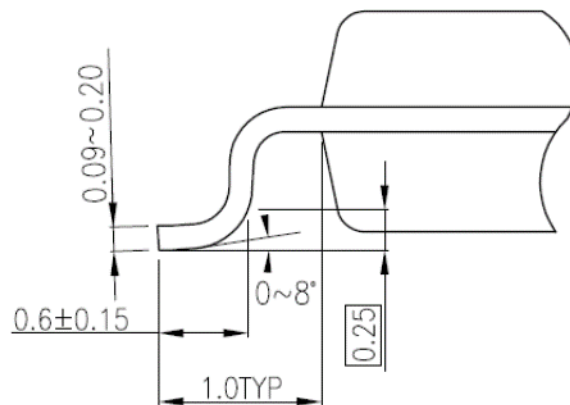
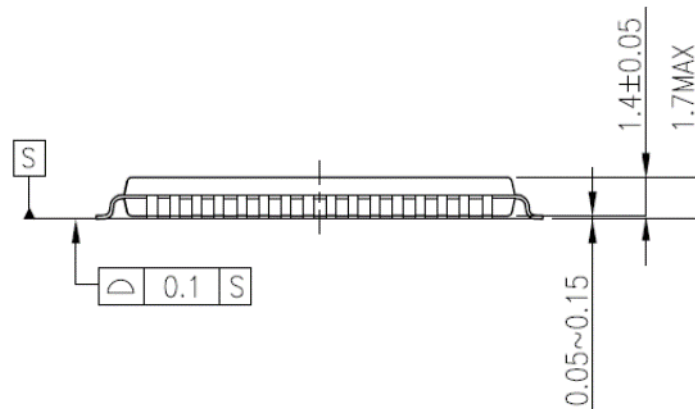
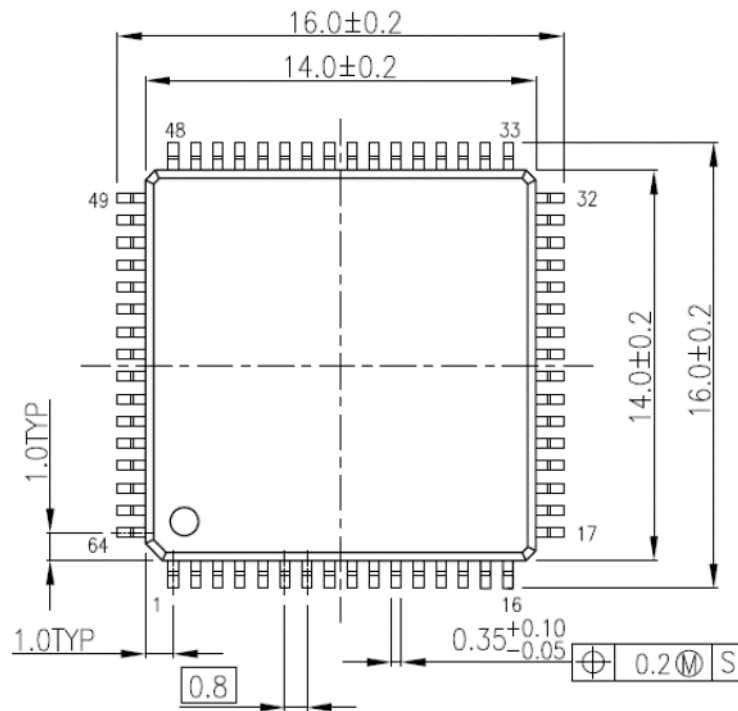

8.7. P-LQFP52-1010-0.65-001

Unit: mm

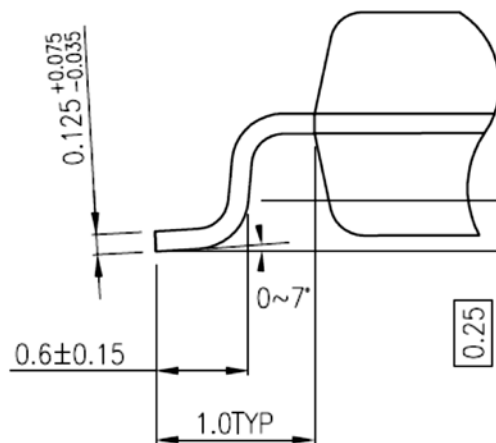
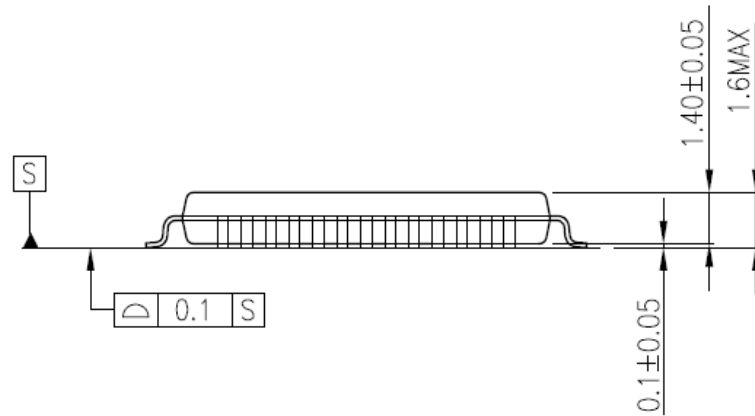
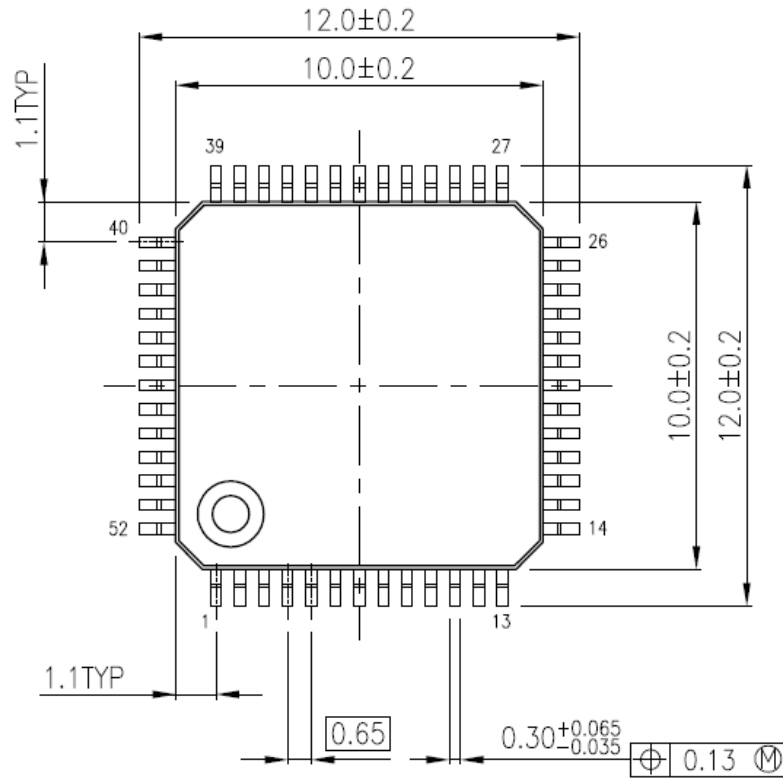

8.8. LQFP48-P-0707-0.50C

Unit: mm

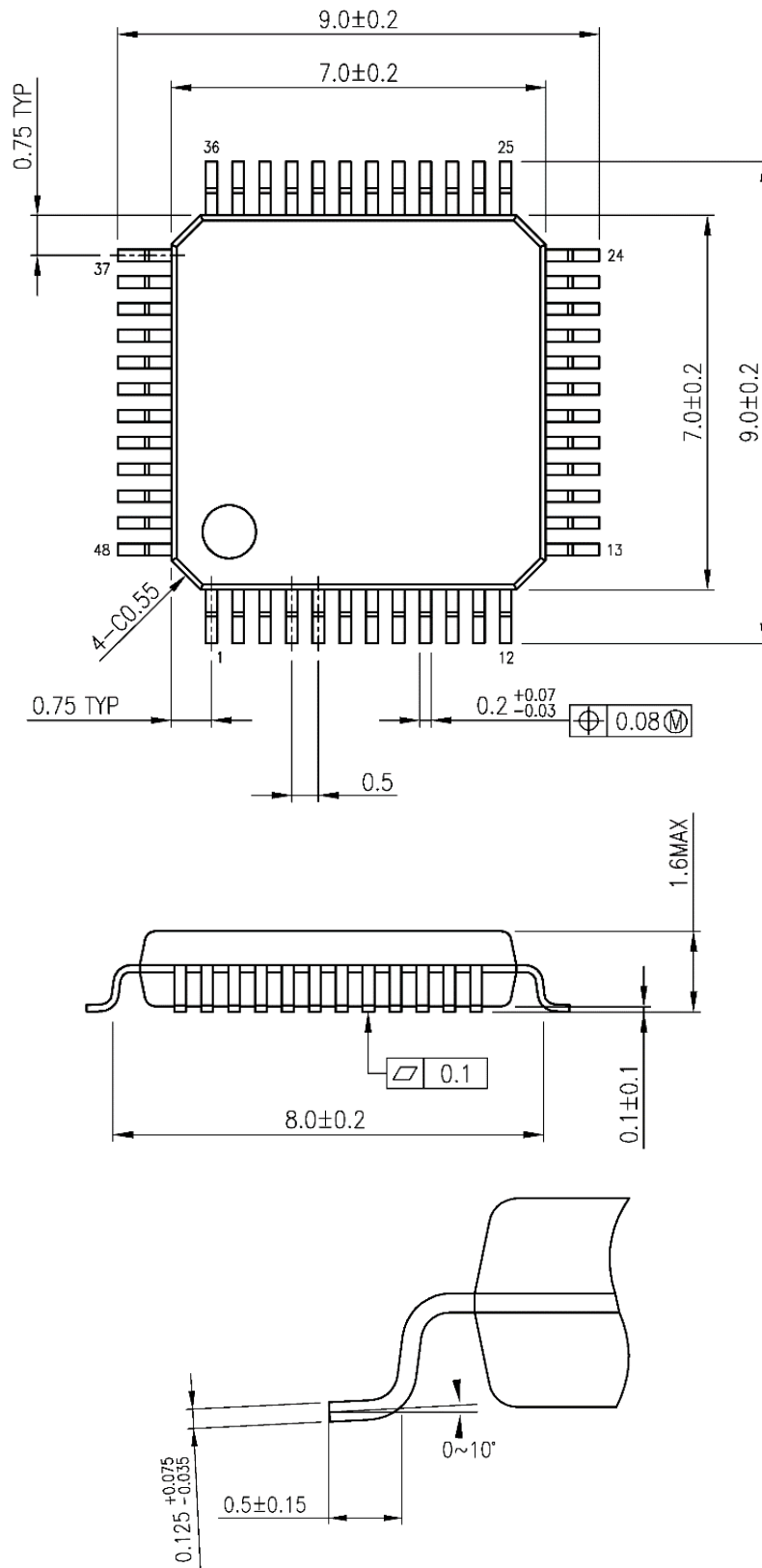

8.10. LQFP44-P-1010-0.80A

Unit: mm

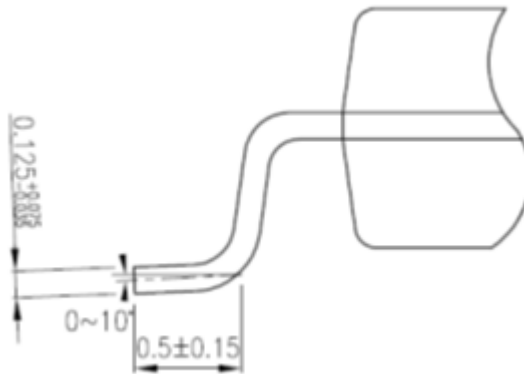
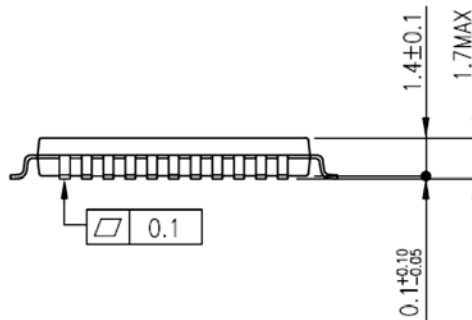
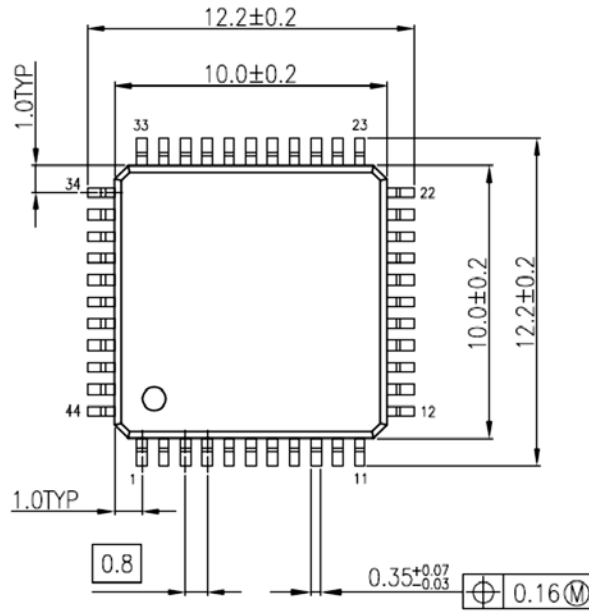

8.11. P-LQFP32-0707-0.80-002

Unit: mm

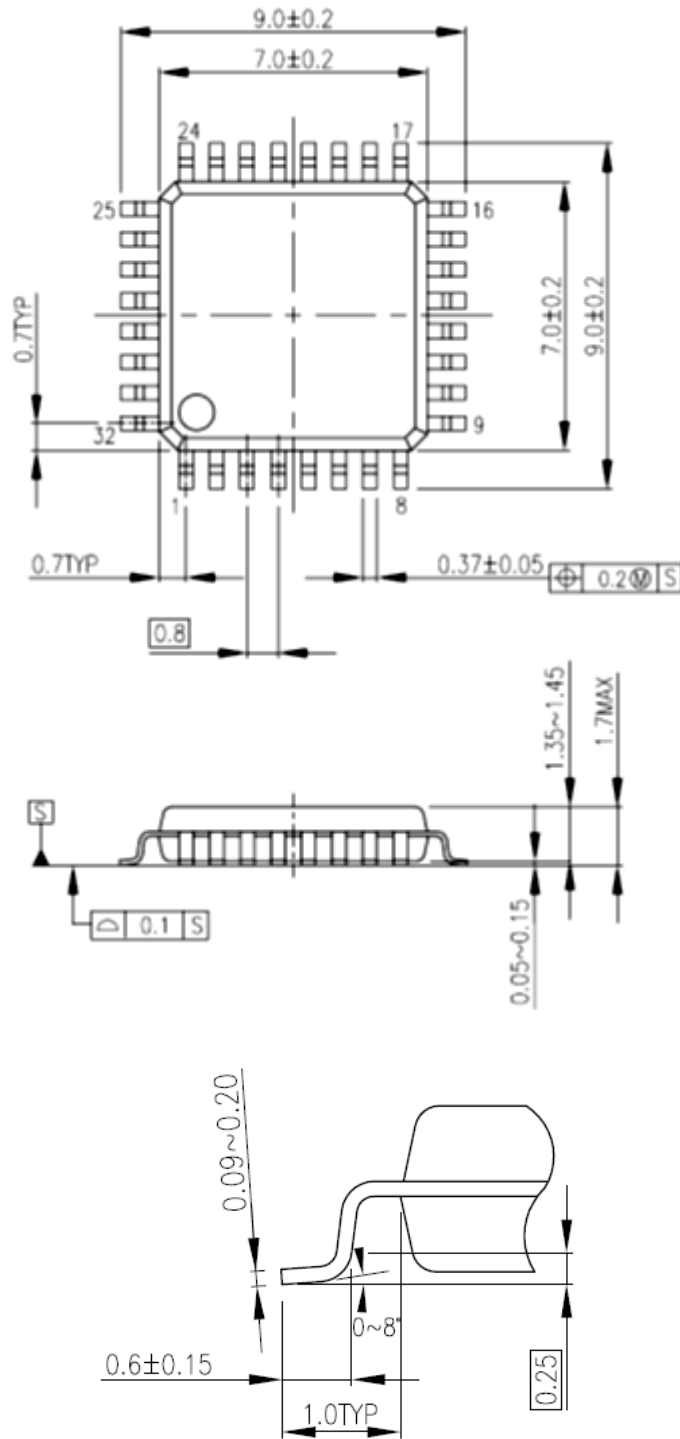

9. Precautions

This Page explains general precautions on the use of Toshiba MCUs.

Note that if there is a difference between the general precautions and the description in the body of the document, the description in the body of document has higher priority.

(1) The MCUs' operation at power-on

At power-on, internal state of the MCUs is unstable. Therefore, the state of the pins is undefined until the reset operation is completed.

When a reset is performed by an external reset pin, pins of the MCUs that use the reset pin are undefined until reset operation by the external pin is completed.

Also, when a reset is performed by the internal power-on reset, pins of the MCUs that use the internal power-on reset are undefined until power supply voltage reaches the voltage at which power-on reset is valid.

(2) Unused pins

Unused input/output ports of the MCUs are prohibited to use. The pins are high-impedance.

Generally, if MCUs operate while the high-impedance pins left open, electrostatic damage or latch-up may occur in the internal LSI due to induced voltage influenced from external noise.

We recommend that each unused pin should be connected to the power supply pins or GND pins via resistors.

(3) Clock oscillation stability

A reset state must be released after the clock oscillation becomes stable. If the clock is changed to another clock while the program is in progress, wait until the clock is stable.

10. Revision History

Table 10.1 Revision History

Revision	Date	Description
Rev.1.0	2017-5-10	New Release
Rev.2.0	2017-08-01	<p>Revised Company Name and related contents</p> <p>Revised ARM Logo/Trademark, character</p> <p>Revised Features: UART(number of FIFO stage)</p> <p>TSPI(number of FIFO stage)</p> <p>5.5 OFD (fIHOSC1 → fEHOSC)</p> <p>5.12 UART number of FIFO stage</p> <p>7.9.1 TSPI "K2" → "k2"</p> <p>7.9.2.3 T32A "unit change "uS" → "ns"</p>
Rev.3.0	2018-04-12	<p>Features: Asynchronous Serial Interface(UART)</p> <p>Corrected to "2.4Mbps (Max)" -> "2.5Mbps (Max)".</p> <p>Terms and Abbreviations: Corrected</p> <p>1. Block Diagram: Corrected the DMAC in Figure 1.1</p> <p>3.1. List of Memory Sizes: Added Code Flash Size to Table 3.1</p> <p>4.2. Functional Pin and Ports Assignment (Pin Number):</p> <p>Corrected to "terminal" -> "pin".</p> <p>Added PB7, PC6 and PR3 of Table 4.19</p> <p>4.3. Ports: Corrected to "State under" -> "Under"</p> <p>Corrected to "State after " -> "After"</p> <p>4.3.1. Port Specification Table: Corrected PB0 of Table 4.20.</p> <p>Corrected PH1,PH3 of Table 4.21.</p> <p>5.1. Reference Manuals: "(Version x)" in Table 5.1 has been deleted.</p> <p>Corrected to "CG-M3H(1)-B" -> "CG-M3H(1)-D" in Table 5.1.</p> <p>5.5. Oscillation Circuit: (EHOSC), (ELOSC) added.</p> <p>5.6. Trimming Circuit (TRM):</p> <p>Corrected to "oscillator (IHOSC1) " -> "oscillator 1 (IHOSC1) "</p> <p>5.7. Oscillation Frequency Detection Circuit (OFD): Corrected to "the external reference clock (fEHOSC) " -> "the internal reference clock (fIHOSC2) "</p> <p>5.9. Digital Noise Filter (DNF): Deleted ("The noise ---- 0.35 to 22.4 μs. ")</p> <p>5.11. DMA Controller (DMAC): Corrected to "DMAC has the 32 channels ----" -> "TMPM3H Group (1) product has one DMA". Deleted "DMA requests of ---- circuit (TRGSEL). "</p> <p>5.14. I²C Interface (I²C): Corrected to "I²C bus Interface" -> "I²C Interface ".</p> <p>5.17. Motor Control Circuit Plus (PMD+):</p> <p>Corrected to "Motor Control Circuit" -> "5.17. Motor Control Circuit Plus"</p> <p>5.21. Clock Selective Watchdog Timer (SIWDT): Corrected to "The WDT is" -> "The SIWDT is".</p> <p>Corrected to "internal oscillator (fIHOSC1), or internal oscillator for the OFD (fIHOSC2) " -> "internal oscillator 1 (fIHOSC1), or internal oscillator 2 for the OFD (fIHOSC2) "</p> <p>6.1. Port: PA6, PA7 ..., PA4, PA5 ..., PH 0 to PH 3 have been corrected</p> <p>6.3. Control Pin: Added "MODE pin must be connected to GND" to MODE BSC.</p> <p>Delete "MODE" "RESET" in the circuit diagram.</p> <p>6.4.Clock control: X1, X2 have been corrected</p> <p>7.1.Absolute Maximum Ratings: Table 7.1</p> <p>AVDD 5 in the Symbol column: "-0.3 to 6.0"->"-0.3 to DVDD5 (Note1) "</p> <p>VIN1 VIN2 in the Symbol column: " (Note1) " Added</p> <p>(Note1) description added</p> <p>7.2. DC Electrical Characteristics (1/2)</p> <p>Corrected parameter "Input leak current". (4.5V ≤DVDD5=AVDD5≤ 5.5 V)</p> <p>Corrected parameter "Output leak current".(4.5V ≤DVDD5=AVDD5≤ 5.5 V)</p> <p>Corrected parameter "Schmitt trigger Input width".(4.5V ≤DVDD5=AVDD5≤ 5.5 V)</p> <p>Corrected parameter " Low level output voltage ".(2.7V ≤DVDD5=AVDD5< 4.5V)</p> <p>Corrected parameter "Schmitt trigger Input width".(2.7V ≤DVDD5=AVDD5< 4.5V)</p> <p>7.3. DC Electrical Characteristics (2/2)</p> <p>Deleted "LOSC = Low Speed Oscillator" in Table 7.2.</p> <p>Corrected Item "Power consumption " -> "Current consumption".</p> <p>7.4. 12-bit AD Converter Characteristics: Corrected of table (Condition, Value, Note)</p> <p>7.5. 8-bit DA Converter Characteristics: Corrected of table (Condition)</p> <p>7.6. Characteristics of Internal processing at RESET:</p> <p>Minimum value of Power-on rising gradient "-" -> "0.01"</p> <p>7.8. Characteristics of Voltage Detection Circuit:</p> <p>The maximum value of "Detection response time" was corrected. ("250"->"200 ")</p>

		<p>7.9.1.2. AC Electrical Characteristics: Figures 7.1 to 7.4 have been corrected. ("<CKPOL>=0"->"<CKPOL>=1", "<CKPOL>=1"->"<CKPOL>=0")</p> <p>7.9.2. I²C Interface (I²C): Corrected to " I²C Bus " -> " I²C Interface " Deleted "- Pull-up resistor: 200 Ω"</p> <p>7.9.3. 32-bit Timer Event Counter (T32A) Corrected to "32-bit Timer/Event Counter" -> "32-bit Timer Event Counter"</p> <p>7.9.3.2. AC Characteristics: Corrected "tPWH" -> "tPWL", "tPWL" -> "tPWH" The signal name in Figure 7.6 has been corrected. "PHCxIN0" -> "T32AxINA0 T32AxINB0 T32AxINC0" "PHCxIN1" -> "T32AxINA1 T32AxINB1 T32AxINC1"</p> <p>7.9.4.1. AC Measurement Conditions: "▪ Ta = -40 °C to 85 °C " added.</p> <p>7.9.4.2. AC Electrical Characteristics: Corrected to "(5) STOP1···" -> "(2) STOP1···"</p> <p>7.9.5.1. AC Measurement Conditions: "▪ Ta = -40 °C to 85 °C " added.</p> <p>7.9.6.1. AC Measurement Conditions: "▪ Ta = -40 °C to 85 °C " added.</p> <p>7.9.7.1. AC Measurement Conditions: "▪ Ta = -40 °C to 85 °C " added.</p> <p>7.9.9.1. AC Measurement Conditions: "▪ Ta = -40 °C to 85 °C " added.</p> <p>7.10.3. Chip Erase: Minimum value of Chip Erase time " 22.7" -> " 23.4" Maximum value of Chip Erase time " 35.2" -> " 62.7"</p> <p>7.12.4. Ceramic Oscillator: Deleted of URL</p> <p>7.12.5. Crystal Oscillator: Corrected of explanation. Deleted of URL. Part Naming Conventions: Update</p> <p>10. Revision History: Added table number "10.1"</p>
Rev.4.0	2018-08-20	<p>Features: Added "Commercial Production Date: 2017-06"</p> <p>Conventions Modified explanation of trademark</p> <p>3. Memory Map: Corrected "Flash for code" -> "Code Flash" in Figure 3.1.</p> <p>4.1.1. Peripheral Function Pins: Deleted "(TRGSEL)" in Table 4.1.</p> <p>5.14. I²C Interface (I²C): Corrected Note2 in Table 5.13. (Note2: The address match wake up function is available.)</p> <p>7.3. DC Electrical Characteristics (2/2): Corrected operating condition in IDLE. Corrected "Transmission(2.4Mbps)" -> "Transmission(2.5Mbps)" of "UART" term in Table 7.3.</p> <p>7.4. 12-bit AD Converter Characteristics: Changed the position of (Note3) in "conversion time" term.</p> <p>7.9.1.2. AC Electrical Characteristics: Corrected "TSPIxTXD hold time" -> "TSPIxTXD delay time" of "tODLY1" term in Table. Deleted "(2) 1st clock edge sampling (Slave)" and Table 7.2.</p> <p>7.9.3.2. AC Characteristics: Deleted signal name in Figure 7.5 (T32AxINA0, T32AxINB0, T32AxINA1, T32AxINB1)</p> <p>RESTRICTIONS ON PRODUCT USE Modified contents</p>
Rev 4.1	2019-07-10	<p>Revised the information of Commercial Production.</p> <p>4.1.1 Table 4.1 modified the function description of UART CTS&RTS. modified the peripheral function column of I2C</p> <p>4.1.3 Table 4.3 modified the function description of BOOT</p> <p>4.1.5 Capacitors between power supply pins added new section</p> <p>6.3 modified the contents of RESET</p> <p>7.6 modified the Warm Reset Min Value of tCPUWT (from 70 to 55)</p> <p>7.9.1.2 modified the condition contents for operation clock.</p> <p>7.9.3.2 modified the condition contents for operation clock.</p> <p>7.9.6.2 modified the Parameter contents. Added the Fig 7.6 of SWD waveform</p> <p>7.9.6.3 modified the Parameter contents. Revised the Fig 7.7 of JTAG waveform</p> <p>7.12.1 revised the Note2 about trimming of IHOSC1/2.</p> <p>Appendix List of All Pins Modified contents, new notification added Part Naming Conventions Revised contents</p>

Appendix

List of All pins

Combination Function A to B: These are the functions which become effective without setting up port function registers.
Combination Function 1 to 6: These are the functions which become effective with setting up port function registers.
The noise filters in the table do not include noise cancelers, digital noise filters (DNF), etc.

List of All pins(1)

M3H0 (LQFP100)	M3H0 (QFP100)	M3H5 (LQFP80)	M3H4 (LQFP84)	M3H3 (LQFP82)	M3H2 (LQFP48 VQFN48)	M3H1 (LQFP44)	M3H0 (LQFP32)	Port Name	Combination FunctionA	Combination FunctionB	Combination Function1	Combination Function2	Combination Function3	Combination Function4	Combination Function5	Combination Function6	PU/PD	OD	5V_T	SMT/OMOS	Noise Filter	Status under RESET	Status after RESET
1	3	-	-	-	-	-	-	PD3	AINA03								PU/PD	YES	N/A	SMT	N/A	Hi-z	Hi-z
2	4	1	1	1	1	1	-	PD2	AINA02								PU/PD	YES	N/A	SMT	N/A	Hi-z	Hi-z
3	5	2	2	2	2	2	1	PD1	AINA01								PU/PD	YES	N/A	SMT	N/A	Hi-z	Hi-z
4	6	3	3	3	3	3	2	PDO	AINA00								PU/PD	YES	N/A	SMT	N/A	Hi-z	Hi-z
5	7	4	4	4	4	4	3	AVDD5									-	-	-	-	-	-	-
6	8	5	5	5	5	5	4	AVSS									-	-	-	-	-	-	-
7	9	6	6	6	6	6	-	PG0	DAC0								PU/PD	YES	N/A	SMT	N/A	Hi-z	Hi-z
8	10	7	-	-	-	-	-	PG1	DAC1								PU/PD	YES	N/A	SMT	N/A	Hi-z	Hi-z
9	11	8	-	-	-	-	-	DVSSG									-	-	-	-	-	-	-
10	12	9	-	-	-	-	-	DVDD5C									-	-	-	-	-	-	-
11	13	10	-	-	-	-	-	PA7		INT11							PU/PD	YES	N/A	SMT	YES	Hi-z	Hi-z
12	14	11	7	7	-	-	-	PA6		INT07							PU/PD	YES	N/A	SMT	YES	Hi-z	Hi-z
13	15	12	8	8	7	6	-	PA5		I2C1SDA				T32A00INB1			PU/PD	YES	YES	SMT	N/A	Hi-z	Hi-z
14	16	13	9	9	8	7	-	PA4		I2C1SCL			TSPI0CS1	T32A00INB0			PU/PD	YES	YES	SMT	N/A	Hi-z	Hi-z
15	17	14	10	10	9	8	-	PA3			TSPI0CSN	TSPI0CS0	T32A00OUTB		TRGNH	PU/PD	YES	N/A	SMT	N/A	Hi-z	Hi-z	
16	18	15	11	11	10	9	5	PA2		UT0RXD	UT0TXDA	TSPI0RXD	T32A00INA1	T32A00INC1	ENC0B	PU/PD	YES	N/A	SMT	N/A	Hi-z	Hi-z	
17	19	16	12	12	11	10	6	PA1		UT0TXDA	UT0RXD	TSPI0TXD	T32A00INA0	T32A00INC0	ENC0B	PU/PD	YES	N/A	SMT	N/A	Hi-z	Hi-z	
18	20	17	13	13	12	11	7	PA0			UT0TXDB		TSPI0SCK	T32A00OUTA	T32A00OUTC	ENC0A	PU/PD	YES	N/A	SMT	N/A	Hi-z	Hi-z
19	21	-	-	-	-	-	-	PM6		INT15							PU/PD	YES	N/A	SMT	YES	Hi-z	Hi-z
20	22	-	-	-	-	-	-	PM5						T32A00INB1			PU/PD	YES	N/A	SMT	N/A	Hi-z	Hi-z
21	23	-	-	-	-	-	-	PM4			UT0RTS_N	UT0CTS_N	TSPI0CS1	T32A00INB0		TRACEATA3	PU/PD	YES	N/A	SMT	N/A	Hi-z	Hi-z
22	24	-	-	-	-	-	-	PM3			UT0CTS_N	UT0RTS_N	TSPI0CS0	T32A00OUTB	TSPI0CSN	TRACEATA2	PU/PD	YES	N/A	SMT	N/A	Hi-z	Hi-z
23	25	18	14	-	-	-	-	PM2		INT09	UT0RXD	UT0TXDA	TSPI0RXD	T32A00INA1	T32A00INC1	TRACEATA1	PU/PD	YES	N/A	SMT	YES	Hi-z	Hi-z
24	26	19	15	-	-	-	-	PM1			UT0TXDA	UT0RXD	TSPI0TXD	T32A00INA0	T32A00INC0	TRACEATA0	PU/PD	YES	N/A	SMT	N/A	Hi-z	Hi-z
25	27	20	16	-	-	-	-	PM0			UT0TXDB		TSPI0SCK	T32A00OUTA	T32A00OUTC	TRACECLK	PU/PD	YES	N/A	SMT	N/A	Hi-z	Hi-z
26	28	21	17	14	13	12	8	PB0	BOOT_N					T32A01OUTA	T32A01OUTC	SCOUT	PU/PD	YES	N/A	SMT	N/A	Hi-z>Note1	Hi-z
27	29	22	18	15	14	13	9	PB1		INT03	RXIN0			T32A01INA0	T32A01INC0	TRGN0	PU/PD	YES	N/A	SMT	YES	Hi-z	Hi-z
28	30	23	19	16	15	14	-	PB2			UT2TXDA	UT2RXD	TSPI1SCK	T32A01INA1	T32A01INC1		PU/PD	YES	N/A	SMT	N/A	Hi-z	Hi-z
29	31	24	20	17	16	15	-	PB3			UT2RXD	UT2TXDA	TSPI1TXD	T32A01OUTB			PU/PD	YES	N/A	SMT	N/A	Hi-z	Hi-z
30	32	25	21	18	17	16	-	PB4			UT2CTS_N(注3)	UT2RTS_N(注3)	TSPI1RXD	T32A01INB0			PU/PD	YES	N/A	SMT	N/A	Hi-z	Hi-z
31	33	-	-	-	-	-	-	PB5			UT2RTS_N	UT2CTS_N	TSPI1CS0	T32A01INB1	TSPI1CSN		PU/PD	YES	N/A	SMT	N/A	Hi-z	Hi-z
32	34	-	-	-	-	-	-	PB6					TSPI1CS1				PU/PD	YES	N/A	SMT	N/A	Hi-z	Hi-z
33	35	-	-	-	-	-	-	PB7									PU/PD	YES	N/A	SMT	N/A	Hi-z	Hi-z
34	36	26	22	19	-	-	-	PL0			UT2TXDA	UT2RXD	I2C2SCL				PU/PD	YES	YES	SMT	N/A	Hi-z	Hi-z
35	37	27	23	20	-	-	-	PL1			UT2RXD	UT2TXDA	I2C2SDA				PU/PD	YES	YES	SMT	N/A	Hi-z	Hi-z
36	38	28	24	-	-	-	-	PL2			UT2CTS_N	UT2RTS_N					PU/PD	YES	N/A	SMT	N/A	Hi-z	Hi-z
37	39	29	25	-	-	-	-	PL3		INT08	UT2RTS_N	UT2CTS_N					PU/PD	YES	N/A	SMT	YES	Hi-z	Hi-z
38	40	30	-	-	-	-	-	PL4		INT12							PU/PD	YES	N/A	SMT	YES	Hi-z	Hi-z
39	41	-	-	-	-	-	-	PL5			TSPI1CS1						PU/PD	YES	N/A	SMT	N/A	Hi-z	Hi-z
40	42	-	-	-	-	-	-	PL6			TSPI1CS0	TSPI1CSN					PU/PD	YES	N/A	SMT	N/A	Hi-z	Hi-z
41	43	31	-	-	-	-	-	PP0			TSPI1SCK		T32A01OUTA	T32A01OUTC			PU/PD	YES	N/A	SMT	N/A	Hi-z	Hi-z
42	44	32	-	-	-	-	-	PP1			TSPI1TXD		T32A01INA0	T32A01INC0			PU/PD	YES	N/A	SMT	N/A	Hi-z	Hi-z
43	45	33	-	-	-	-	-	PP2			TSPI1RXD		T32A01INA1	T32A01INC1			PU/PD	YES	N/A	SMT	N/A	Hi-z	Hi-z
44	46	34	26	21	18	17	10	DVDD5A									-	-	-	-	-	-	-
45	47	35	27	22	19	18	11	REGOUT2									-	-	-	-	-	-	-
46	48	36	28	23	20	19	12	REGOUT1									-	-	-	-	-	-	-
47	49	37	29	24	21	20	13	DVSSA									-	-	-	-	-	-	-
48	50	38	30	25	22	21	14	PH0	X1	EHOLKIN							PD	N/A	N/A	SMT	N/A	Hi-z	Hi-z
49	51	39	31	26	23	22	15	PH1	X2								PD	N/A	N/A	SMT	N/A	Hi-z	Hi-z
50	52	40	32	27	24	23	16	RESET_N									PU	-	-	SMT	-	-	-
51	53	41	33	28	25	-	-	PH2	XT1								PD	N/A	N/A	SMT	N/A	Hi-z	Hi-z
52	54	42	34	29	26	-	-	PH3	XT2	INT06							PD	N/A	N/A	SMT	YES	Hi-z	Hi-z
53	55	43	35	30	27	24	17	MODE									PD	N/A	N/A	SMT	N/A	-	-
54	56	44	36	31	28	25	18	PC0		INT00	I2C0SCL		T32A02OUTA	T32A02OUTC			PU/PD	YES	YES	SMT	YES	Hi-z	Hi-z
55	57	45	37	32	29	26	19	PC1		INT01	I2C0SDA		T32A02INA0	T32A02INC0			PU/PD	YES	YES	SMT	YES	Hi-z	Hi-z
56	58	46	38	33	30	27	20	PC2		INT02			T32A02INA1	T32A02INC1	RTCOU(注2)		PU/PD	YES	N/A	SMT	YES	Hi-z	Hi-z
57	59	47	39	34	31	-	-	PC3					T32A02OUTB				PU/PD	YES	N/A	SMT	N/A	Hi-z	Hi-z
58	60	48	-	-	-	-	-	PC4					T32A02INB0				PU/PD	YES	N/A	SMT	N/A	Hi-z	Hi-z
59	61	49	-	-	-	-	-	PC5					T32A02INB1				PU/PD	YES	N/A	SMT	N/A	Hi-z	Hi-z
60	62	50	-	-	-	-	-	PC6									PU/PD	YES	N/A	SMT	N/A	Hi-z	Hi-z

Note1: When the RESET_N pin is "Low", a built-in pull-up resistor becomes effective.

Note2: The RTCOUT is invalid in the M3H1 and M3H0.

Note3: The UT2CTS_N/UT2RTS_N of PB4 is invalid in the M3H5, M3H4, M3H3, M3H2, M3H1 and M3H0.

List of All pins(2)

M3H0 (LQFP100)	M3H0 (QFP100)	M3H5 (LQFP80)	M3H4 (LQFP84)	M3H3 (LQFP52)	M3H2 (LQFP48 VQFN48)	M3H1 (LQFP44)	M3H0 (LQFP32)	Port Name	Combination FunctionA	Combination FunctionB	Combination Function1	Combination Function2	Combination Function3	Combination Function4	Combination Function5	Combination Function6	PU/PD	OD	5V_T	SMT/ OMOS	Noise Filter	Status under RESET	Status after RESET
61	63	-	-	-	-	-	-	PR0					T32A020UTA	T32A020UTC			PU/PD	YES	N/A	SMT	N/A	Hi-z	Hi-z
62	64	-	-	-	-	-	-	PR1					T32A020NA0	T32A020NC0			PU/PD	YES	N/A	SMT	N/A	Hi-z	Hi-z
63	65	-	-	-	-	-	-	PR2					T32A020NA1	T32A020NC1			PU/PD	YES	N/A	SMT	N/A	Hi-z	Hi-z
64	66	-	-	-	-	-	-	PR3									PU/PD	YES	N/A	SMT	N/A	Hi-z	Hi-z
65	67	-	-	-	-	-	-	PN5					T32A050NB1				PU/PD	YES	N/A	SMT	N/A	Hi-z	Hi-z
66	68	51	-	-	-	-	-	PN4					T32A050NB0				PU/PD	YES	N/A	SMT	N/A	Hi-z	Hi-z
67	69	52	40	-	-	-	-	PN3		INT10			T32A050UTB		TRGN2		PU/PD	YES	N/A	SMT	YES	Hi-z	Hi-z
68	70	53	41	-	-	-	-	PN2					T32A050NA1	T32A050NC1			PU/PD	YES	N/A	SMT	N/A	Hi-z	Hi-z
69	71	54	42	-	-	-	-	PN1					T32A050NA0	T32A050NC0			PU/PD	YES	N/A	SMT	N/A	Hi-z	Hi-z
70	72	55	43	-	-	-	-	PN0					T32A050UTA	T32A050UTC			PU/PD	YES	N/A	SMT	N/A	Hi-z	Hi-z
71	73	56	44	35	32	28	21	PJ0			UT1TXDB		T32A030UTA	T32A030UTC	U00		PU/PD	YES	N/A	SMT	N/A	Hi-z	Hi-z
72	74	57	45	36	33	29	22	PJ1			UT1TXDA	UT1RXD	T32A030NA0	T32A030NC0	X00		PU/PD	YES	N/A	SMT	N/A	Hi-z	Hi-z
73	75	58	46	37	34	30	23	PJ2			UT1RXD	UT1TXDA	T32A030NA1	T32A030NC1	V00		PU/PD	YES	N/A	SMT	N/A	Hi-z	Hi-z
74	76	59	47	38	35	31	24	PJ3			UT1CTS_N	UT1RTS_N	T32A030UTB		Y00		PU/PD	YES	N/A	SMT	N/A	Hi-z	Hi-z
75	77	60	48	39	36	32	25	PJ4		INT04	UT1RTS_N	UT1CTS_N	T32A030NB0		W00		PU/PD	YES	N/A	SMT	YES	Hi-z	Hi-z
76	78	61	49	40	37	33	26	PJ5					T32A030NB1		Z00		PU/PD	YES	N/A	SMT	N/A	Hi-z	Hi-z
77	79	62	50	41	38	34	27	PK0			UT1TXDB				EMQ0_N		PU/PD	YES	N/A	SMT	N/A	Hi-z	Hi-z
78	80	63	51	42	39	35	28	PK1		INT05	UT1TXDA	UT1RXD			OVV0_N		PU/PD	YES	N/A	SMT	YES	Hi-z	Hi-z
79	81	64	52	43	40	36	29	PK2			UT1RXD	UT1TXDA	T32A040UTA	T32A040UTC	TMS/SWDIO		PU/PD	YES	N/A	SMT	N/A	PU	PU
80	82	65	53	44	41	37	30	PK3			UT1CTS_N(注1)	UT1RTS_N(注1)	T32A040NA0	T32A040NC0	TCK/SWCLK		PU/PD	YES	N/A	SMT	N/A	PD	PD
81	83	66	54	45	42	38	-	PK4			UT1RTS_N	UT1CTS_N	T32A040NA1	T32A040NC1	TDO/SWV		PU/PD	YES	N/A	SMT	N/A	Hi-z	Hi-z
82	84	67	55	46	43	39	-	PK5					T32A040UTB		TDI		PU/PD	YES	N/A	SMT	N/A	PU	PU
83	85	68	56	-	-	-	-	PK6					T32A040NB0		TRST_N		PU/PD	YES	N/A	SMT	N/A	PU	PU
84	86	69	-	-	-	-	-	PK7		INT13			T32A040NB1				PU/PD	YES	N/A	SMT	YES	Hi-z	Hi-z
85	87	70	-	-	-	-	-	PP3		INT14							PU/PD	YES	N/A	SMT	YES	Hi-z	Hi-z
86	88	71	57	47	-	-	-	BSC									PD	N/A	N/A	SMT	N/A	-	-
87	89	72	58	-	-	-	-	DVDD5B									-	-	-	-	-	-	-
88	90	73	59	-	-	-	-	DVSSB									-	-	-	-	-	-	-
89	91	-	-	-	-	-	-	PF4	ANA15								PU/PD	YES	N/A	SMT	N/A	Hi-z	Hi-z
90	92	-	-	-	-	-	-	PF3	ANA14								PU/PD	YES	N/A	SMT	N/A	Hi-z	Hi-z
91	93	-	-	-	-	-	-	PF2	ANA13								PU/PD	YES	N/A	SMT	N/A	Hi-z	Hi-z
92	94	-	-	-	-	-	-	PF1	ANA12								PU/PD	YES	N/A	SMT	N/A	Hi-z	Hi-z
93	95	-	-	-	-	-	-	PF0	ANA11								PU/PD	YES	N/A	SMT	N/A	Hi-z	Hi-z
94	96	74	-	-	-	-	-	PE6	ANA10								PU/PD	YES	N/A	SMT	N/A	Hi-z	Hi-z
95	97	75	-	-	-	-	-	PE5	ANA09								PU/PD	YES	N/A	SMT	N/A	Hi-z	Hi-z
96	98	76	60	48	44	40	-	PE4	ANA08								PU/PD	YES	N/A	SMT	N/A	Hi-z	Hi-z
97	99	77	61	49	45	41	-	PE3	ANA07								PU/PD	YES	N/A	SMT	N/A	Hi-z	Hi-z
98	100	78	62	50	46	42	-	PE2	ANA06								PU/PD	YES	N/A	SMT	N/A	Hi-z	Hi-z
99	1	79	63	51	47	43	31	PE1	ANA05								PU/PD	YES	N/A	SMT	N/A	Hi-z	Hi-z
100	2	80	64	52	48	44	32	PE0	ANA04								PU/PD	YES	N/A	SMT	N/A	Hi-z	Hi-z

Note1: The UT1CTS_N/UT1RTS_N of PK3 is invalid in the M3H0.

Part Naming Conventions

TMP M3H 4 F W x UG

The identification of
Toshiba microcontrollers

Core

Symbol	Core
M4	Arm Cortex-M4 processor with FPU
M3	Arm Cortex-M3
M0	Arm Cortex-M0

Product Group

Family	Group	Application
TXZ	H	For General-purpose/Consumer electronic equipment
	K	For Motor/Inverter control industrial equipment(MCU+AMP/COMP)
	G	For OA/Digital equipment/industrial equipment
	E	For Precision instruments control
	P	For Healthcare/ Battery equipment
	J	For FA / Robotics

Revision

Package

Symbol	Package
QG	Plastic shrink quad outline non-leaded package; dry-packed
UG,DUG, FG,DFG	Plastic quad flat package; dry-packed
MG,DMG	Plastic small-outline package; dry-packed
XBG	Plastic ball grid array; dry-packed

ROM Size

Symbol	Size[KB]
M	32
P	48
S	64
U	96
W	128
Y	256
Z	384
D	512
E	768
10	1,023
15	1,536
20	2,048
40	4,096
80	8,192

Pin Count

Symbol	Pin Count	Symbol	Pin Count
0	G	8	Q
1	H	9	R
2	J	A	S
3	K	B	T
4	L	C	U
5	M	D	V
6	N		
7	P		

ROM Type

Symbol	Type
F	Flash
C	Mask

RESTRICTIONS ON PRODUCT USE

Toshiba Corporation and its subsidiaries and affiliates are collectively referred to as "TOSHIBA". Hardware, software and systems described in this document are collectively referred to as "Product".

- TOSHIBA reserves the right to make changes to the information in this document and related Product without notice.
- This document and any information herein may not be reproduced without prior written permission from TOSHIBA. Even with TOSHIBA's written permission, reproduction is permissible only if reproduction is without alteration/omission.
- Though TOSHIBA works continually to improve Product's quality and reliability, Product can malfunction or fail. Customers are responsible for complying with safety standards and for providing adequate designs and safeguards for their hardware, software and systems which minimize risk and avoid situations in which a malfunction or failure of Product could cause loss of human life, bodily injury or damage to property, including data loss or corruption. Before customers use the Product, create designs including the Product, or incorporate the Product into their own applications, customers must also refer to and comply with (a) the latest versions of all relevant TOSHIBA information, including without limitation, this document, the specifications, the data sheets and application notes for Product and the precautions and conditions set forth in the "TOSHIBA Semiconductor Reliability Handbook" and (b) the instructions for the application with which the Product will be used with or for. Customers are solely responsible for all aspects of their own product design or applications, including but not limited to (a) determining the appropriateness of the use of this Product in such design or applications; (b) evaluating and determining the applicability of any information contained in this document, or in charts, diagrams, programs, algorithms, sample application circuits, or any other referenced documents; and (c) validating all operating parameters for such designs and applications. **TOSHIBA ASSUMES NO LIABILITY FOR CUSTOMERS' PRODUCT DESIGN OR APPLICATIONS.**
- **PRODUCT IS NEITHER INTENDED NOR WARRANTED FOR USE IN EQUIPMENTS OR SYSTEMS THAT REQUIRE EXTRAORDINARILY HIGH LEVELS OF QUALITY AND/OR RELIABILITY, AND/OR A MALFUNCTION OR FAILURE OF WHICH MAY CAUSE LOSS OF HUMAN LIFE, BODILY INJURY, SERIOUS PROPERTY DAMAGE AND/OR SERIOUS PUBLIC IMPACT ("UNINTENDED USE").** Except for specific applications as expressly stated in this document, Unintended Use includes, without limitation, equipment used in nuclear facilities, equipment used in the aerospace industry, lifesaving and/or life supporting medical equipment, equipment used for automobiles, trains, ships and other transportation, traffic signaling equipment, equipment used to control combustions or explosions, safety devices, elevators and escalators, and devices related to power plant. **IF YOU USE PRODUCT FOR UNINTENDED USE, TOSHIBA ASSUMES NO LIABILITY FOR PRODUCT.** For details, please contact your TOSHIBA sales representative or contact us via our website.
- Do not disassemble, analyze, reverse-engineer, alter, modify, translate or copy Product, whether in whole or in part.
- Product shall not be used for or incorporated into any products or systems whose manufacture, use, or sale is prohibited under any applicable laws or regulations.
- The information contained herein is presented only as guidance for Product use. No responsibility is assumed by TOSHIBA for any infringement of patents or any other intellectual property rights of third parties that may result from the use of Product. No license to any intellectual property right is granted by this document, whether express or implied, by estoppel or otherwise.
- **ABSENT A WRITTEN SIGNED AGREEMENT, EXCEPT AS PROVIDED IN THE RELEVANT TERMS AND CONDITIONS OF SALE FOR PRODUCT, AND TO THE MAXIMUM EXTENT ALLOWABLE BY LAW, TOSHIBA (1) ASSUMES NO LIABILITY WHATSOEVER, INCLUDING WITHOUT LIMITATION, INDIRECT, CONSEQUENTIAL, SPECIAL, OR INCIDENTAL DAMAGES OR LOSS, INCLUDING WITHOUT LIMITATION, LOSS OF PROFITS, LOSS OF OPPORTUNITIES, BUSINESS INTERRUPTION AND LOSS OF DATA, AND (2) DISCLAIMS ANY AND ALL EXPRESS OR IMPLIED WARRANTIES AND CONDITIONS RELATED TO SALE, USE OF PRODUCT, OR INFORMATION, INCLUDING WARRANTIES OR CONDITIONS OF MERCHANTABILITY, FITNESS FOR A PARTICULAR PURPOSE, ACCURACY OF INFORMATION, OR NONINFRINGEMENT.**
- Do not use or otherwise make available Product or related software or technology for any military purposes, including without limitation, for the design, development, use, stockpiling or manufacturing of nuclear, chemical, or biological weapons or missile technology products (mass destruction weapons). Product and related software and technology may be controlled under the applicable export laws and regulations including, without limitation, the Japanese Foreign Exchange and Foreign Trade Law and the U.S. Export Administration Regulations. Export and re-export of Product or related software or technology are strictly prohibited except in compliance with all applicable export laws and regulations.
- Please contact your TOSHIBA sales representative for details as to environmental matters such as the RoHS compatibility of Product. Please use Product in compliance with all applicable laws and regulations that regulate the inclusion or use of controlled substances, including without limitation, the EU RoHS Directive. **TOSHIBA ASSUMES NO LIABILITY FOR DAMAGES OR LOSSES OCCURRING AS A RESULT OF NONCOMPLIANCE WITH APPLICABLE LAWS AND REGULATIONS.**

X-ON Electronics

Largest Supplier of Electrical and Electronic Components

Click to view similar products for [ARM Microcontrollers - MCU category](#):

Click to view products by [Toshiba manufacturer](#):

Other Similar products are found below :

[R7FS3A77C2A01CLK#AC1](#) [CP8363AT](#) [MB96F119RBPMC-GSE1](#) [MB9BF122LPMC1-G-JNE2](#) [MB9BF122LPMC-G-JNE2](#)

[MB9BF128SAPMC-GE2](#) [MB9BF218TBGL-GE1](#) [MB9BF529TBGL-GE1](#) [26-21/R6C-AT1V2B/CT](#) [5962-8506403MQA](#)

[MB9AF342MAPMC-G-JNE2](#) [MB96F001YBPMC1-GSE1](#) [MB9BF121KPMC-G-JNE2](#) [VA10800-D000003PCA](#) [CP8547AT](#)

[CY9AF156NPMC-G-JNE2](#) [MB9BF104NAPMC-G-JNE1](#) [CY8C4724FNI-S402T](#) [ADUCM410BCBZ-RL7](#) [ADUCM410BBCZ-RL7](#)

[GD32f303RGT6](#) [NHS3152UK/A1Z](#) [MK26FN2M0CAC18R](#) [EFM32TG230F32-D-QFN64](#) [EFM32TG232F32-D-QFP64](#) [EFM32TG825F32-D-](#)

[BGA48](#) [MB9AFB44NBBGL-GE1](#) [MB9BF304RBPMC-G-JNE2](#) [MB9BF416RPMC-G-JNE2](#) [MB9AF155MABGL-GE1](#) [MB9BF306RBPMC-](#)

[G-JNE2](#) [MB9BF618TBGL-GE1](#) [MK20DX64VFT5](#) [MK50DX128CMC7](#) [MK51DN256CMD10](#) [MK51DX128CMC7](#) [MK53DX256CMD10](#)

[MKL25Z32VFT4](#) [MKL25Z64VFT4](#) [LPC1754FBD80](#) [STM32F030K6T6TR](#) [STM32L073VBT6](#) [AT91M42800A-33AU](#) [AT91SAM7L64-CU](#)

[ATSAM3N0AA-MU](#) [ATSAM3N0CA-CU](#) [ATSAM3SD8BA-MU](#) [ATSAM4LC2BA-UUR](#) [ATSAM4LC4BA-MU](#) [ATSAM4LS2AA-MU](#)