

Features

- ◆ Smallest encapsulated 30 W converter
- ◆ 2" x 1" x 0.4" shielded metal package with isolated baseplate
- ◆ Single- and dual output models
- ◆ I/O isolation voltage 1500 VDC
- ◆ Excellent efficiency up to 91 %
- ◆ Operating temperature range -40°C to +85°C
- ◆ Remote On/Off
- ◆ Over-temperature protection
- ◆ 3-year product warranty



The TEN-30 series is the latest generation of high performance dc-dc converter modules setting a new standard concerning power density. This product with 30W comes in an encapsulated, shielded metal package with a footprint of only 1.0" x 2.0". All models have wide 2:1 input voltage range and precisely regulated, isolated output voltages. Advanced circuit topology provides high efficiency up to 91% which allows an industrial operating temperature range of -40°C to +85°C (with derating).

Further features include remote On/Off, trimmable output, under-voltage lockout and overtemperature protection. Typical applications for these converters are mobile equipment, instrumentation, distributed power architectures in communication and industrial electronics and everywhere where space on the PCB is critical.

Models

Ordercode	Input voltage	Output voltage	Output current max.	Efficiency typ.
TEN 30-1210	9 – 18 VDC (nominal 12 VDC)	3.3 VDC	8'000 mA	85 %
TEN 30-1211		5.1 VDC	6'000 mA	87 %
TEN 30-1212		12 VDC	2'500 mA	89 %
TEN 30-1213		15 VDC	2'000 mA	89 %
TEN 30-1221		±5 VDC	±3'000 mA	87 %
TEN 30-1222		±12 VDC	±1'250 mA	87 %
TEN 30-1223		±15 VDC	±1'000 mA	87 %
TEN 30-2410	18 – 36 VDC (nominal 24 VDC)	3.3 VDC	8'000 mA	87 %
TEN 30-2411		5.1 VDC	6'000 mA	90 %
TEN 30-2412		12 VDC	2'500 mA	91 %
TEN 30-2413		15 VDC	2'000 mA	91 %
TEN 30-2421		±5 VDC	±3'000 mA	90 %
TEN 30-2422		±12 VDC	±1'250 mA	89 %
TEN 30-2423		±15 VDC	±1'000 mA	90 %
TEN 30-4810	36 – 75 VDC (nominal 48 VDC)	3.3 VDC	7'500 mA	87 %
TEN 30-4811		5.1 VDC	6'000 mA	89 %
TEN 30-4812		12 VDC	2'500 mA	91 %
TEN 30-4813		15 VDC	2'000 mA	91 %
TEN 30-4821		±5 VDC	±3'000 mA	90 %
TEN 30-4822		±12 VDC	±1'250 mA	88 %
TEN 30-4823		±15 VDC	±1'000 mA	89 %

Input Specifications

Input current at no load	- 12 Vin models	±12 / ±15 Vout models:	50 mA typ.
	- 24 Vin models	other output models:	110 mA typ.
	- 48 Vin models	5.1 / ±5 Vout models:	70 mA typ.
		other output models:	40 mA typ.
		±15 Vout model:	20 mA typ.
		other output models:	50 mA typ.
Input current at full load	- 12 Vin models	3.3 Vout models:	2700 mA typ.
	- 24 Vin models	other output models:	3000 mA typ.
	- 48 Vin models	3.3 Vout models:	1300 mA typ.
		other output models:	1500 mA typ.
		3.3 Vout models:	650 mA typ.
		other output models:	750 mA typ.
Start-up voltage / under voltage shut down		12 V models:	9 VDC / 8 VDC typ.
		24 V models:	18 VDC / 16 VDC typ.
		48 V models:	36 VDC / 32 VDC typ.
Surge voltage (100 ms max.)		12 V models:	25 V max.
		24 V models:	50 V max..
		48 V models:	100 V max.
Conducted noise (input)			EN 55032 class A (with external components)
		Please refer to Application note:	www.tracopower.com/overview/ten30

Output Specifications

Voltage set accuracy		±1 %
Output voltage adj. range		±10 % (only for single output models)
Regulation	- Input variation Vin min. to Vin max.	0.2 % max.
	- Load variation 0 – 100 %	single output models: 0.5 % max.
		dual output models balanced load: 1.0 % max.
		dual output models unbalanced load (25% /100%): 5.0 % max.
Minimum load		not required
Temperature coefficient		±0.02 %/K
Ripple and noise (20 MHz Bandwidth)		100 mVpk-pk max. (150 mVpk-pk for 12/±12/15/±15V models)
Start up time (nominal Vin and constant resistive load)		30 ms typ.
Transient response time (25% load change)		250 µs typ.
Short circuit protection		indefinite, automatic recovery
Over load protection		150 % of lout max. typ.
Over voltage protection	3.3 VDC models:	3.9 V
	5.1 VDC models:	6.2 V
	12 VDC models:	15 V
	15 VDC models:	18 V
Capacitive load (max.)	3.3 Vout models:	20'000 µF
	5.1 Vout models:	14'400 µF
	12 Vout models:	3'000 µF
	15 Vout models:	2'000 µF
	±5 Vout models:	3'000 µF (each output)
	±12 Vout models:	2'000 µF (each output)
	±15 Vout models:	1'300 µF (each output)

All specifications valid at nominal input voltage, full load and +25°C after warm-up time unless otherwise stated.

General Specifications

Temperature ranges	<ul style="list-style-type: none"> - Operating - Case temperature - Storage 	<ul style="list-style-type: none"> - 40°C to +85°C +105°C max. - 55°C to +125°C
Load derating		3.3 %/K above +60°C
Over temperature protection		at +115°C typ.
Humidity (non condensing)		5 % to 95 % rel H max.
Thermal impedance	<ul style="list-style-type: none"> - Natural convection - Natural convection with heat sink 	<ul style="list-style-type: none"> 12 °C/W 10 °C/W
Reliability, calculated MTBF (MIL-HDBK-217F, at +25°C, ground benign)		1.4 Mio. h
Isolation voltage (60 s)	- Input/Output	1'500 VDC
Isolation capacitance	- Input/Output	1500 pF max.
Isolation resistance	- Input/Output (500 VDC)	>1'000 MOhm
Remote On/Off:	<ul style="list-style-type: none"> - On: - Off: - Standby current: 	<ul style="list-style-type: none"> 3 to 12 VDC or open circuit. 0 to 1.2 VDC or short circuit pin 3 and pin 2 3 mA max.
Altitude during operation		5'000 m max.
Switching frequency (fixed)		430 kHz typ. (puls width modulation)
Vibration and thermal shock		MIL-STD-810F
Safety approvals		cUL/UL 60950-1, IEC/EN 60950-1 UL 62368-1. IEC/EN 62368-1 www.tracopower.com/overview/ten30
	- Certification documents	

Output Voltage Adjustment

Trim up

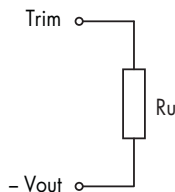

Nominal output voltage at open Trim input!

Trim down

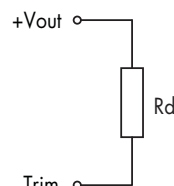

Ru [kohm]

output	1.5	2.5	3.3V	5.1V	12V	15V
+5%	0.56	4.3	6.8	5.1	43	47
+10%	0.051	0.33	0.75	0.75	4.3	1.8

Rd [kohm]

output	1.5	2.5	3.3V	5.1V	12V	15V
-5%	0.68	6.2	8.2	6.2	56	56
-10%	0.062	0.75	0.62	0.82	5.6	2.2

Physical Specifications

Casing material		copper, nickel plated
Baseplate		non conductive FR4
Potting material		epoxy (UL 94V-0 -rated)
Weight		31 g (1.1 oz)
Soldering temperature		max. 265°C / 10 s
Environmental compliance	<ul style="list-style-type: none"> - Reach - RoHS 	www.tracopower.com/info/reach-declaration.pdf RoHS directive 2011/65/EU

Supporting documents: www.tracopower.com/overview/ten30

All specifications valid at nominal input voltage, full load and +25°C after warm-up time unless otherwise stated.

Outline Dimensions

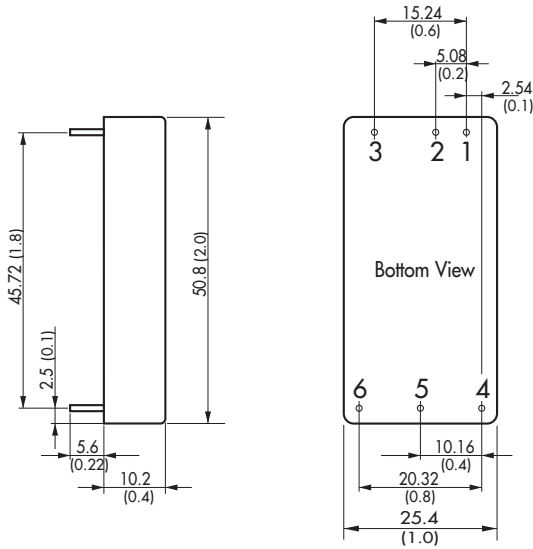

Pin-Out		
Pin	Single	Dual
1	+Vin (Vcc)	+Vin (Vcc)
2	-Vin (GND)	-Vin (GND)
3	Remote On/Off	
4	+ Vout	+ Vout
5	-Vout	Common
6	Trim	-Vout

Dimensions in [mm], () = Inch
 Pin diameter: 1.0 ±0.1 (0.04 ±0.004)
 Pin pitch tolerances: ±0.25 (±0.01)
 Case tolerances: ±0.5 (±0.02)

Heat-Sink (Option)

Order code: TEN-HS1
 (cont.: heat-sink, thermal pad, 2 clamps)
Material: Aluminum
Finish: Anodic treatment (black)
Weight: 17g (0.60oz) without converter
 Thermal impedance after assembling: 10 K/W



Note:
 The product label on converter has to be removed before mounting the heat-sink.
 For volume orders converters will be supplied with heat-sinks already mounted. Please contact factory for quotation.
 Separate heat-sinks are only available for prototypes and small quantity orders.

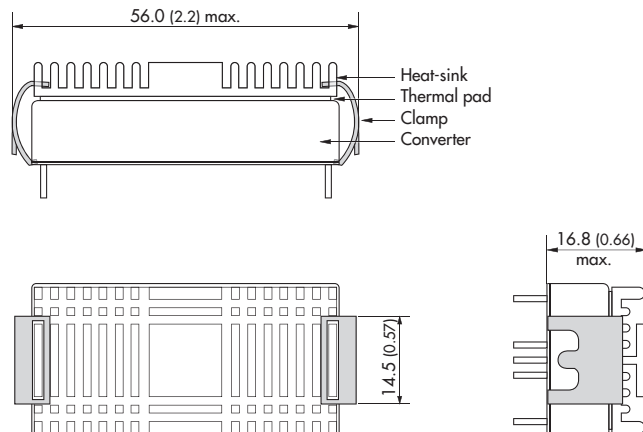

Specifications can be changed without notice! Make sure you are using the latest documentation, downloadable at www.tracopower.com

X-ON Electronics

Largest Supplier of Electrical and Electronic Components

Click to view similar products for [Isolated DC/DC Converters](#) category:

Click to view products by [TRACO Power](#) manufacturer:

Other Similar products are found below :

[ESM6D044440C05AAQ](#) [FMD15.24G](#) [PSL486-7LR](#) [Q48T30020-NBB0](#) [JAHW100Y1](#) [SPB05C-12](#) [SQ24S15033-PS0S](#) [18952](#) [19-130041](#)
[CE-1003](#) [CE-1004](#) [GQ2541-7R](#) [RDS180245](#) [MAU228](#) [J80-0041NL](#) [DFC15U48D15](#) [XGS-0512](#) [XGS-1205](#) [XGS-1212](#) [XGS-2412](#) [XGS-2415](#) [XKS-1215](#) [06322](#) [NCT1000N040R050B](#) [SPB05B-15](#) [SPB05C-15](#) [L-DA20](#) [DCG40-5G](#) [QME48T40033-PGB0](#) [XKS-2415](#) [XKS-2412](#)
[XKS-1212](#) [XKS-1205](#) [XKS-0515](#) [XKS-0505](#) [XGS-2405](#) [XGS-1215](#) [XGS-0515](#) [PS9Z-6RM4](#) [73-551-5038I](#) [AK1601-9RT](#) [VI-N61-CM](#) [VI-R5022-EXWW](#) [PSC128-7iR](#) [RPS8-350ATX-XE](#) [DAS1004812](#) [PQA30-D24-S24-DH](#) [VI-M5F-CQ](#) [VI-LN2-EW](#) [VI-PJW01-CZY](#)