

- High power density 3" x 5.8" encased medical power supply
- Protection class II prepared
- 450 Watt up to 65°C without derating, 320 Watt fanless operation without derating up to 50°C
- Medical certification to IEC/EN/ES 60601-1 3rd edition for 2 x MOPP
- EMC compliance to IEC/EN 60601-1-2 4th edition
- Risk management process according to ISO 14971 incl. risk management file
- Isolation (4000 VAC) and leakage current (<100 µA) rated for BF applications
- Standard features: 5 V standby output, 12 V fan output, Remote On/Off, Power Good Signal, variable fan speed
- Operating up to 5000 m altitude
- 5-year product warranty



The TPP 450B-M Series of 450 Watt AC/DC power supplies feature a reinforced double I/O isolation system according to latest medical safety standards (60601-1 3rd edition, 2 x MOPP) and is suitable for class II applications. The earth leakage current is below 100 µA what makes the units suitable for BF (body floating) applications. The excellent efficiency of up to 94% allows a high power density for the standard 3" x 5" packaging format. Fanless operation power is 320W up to +50°C and 450W at +65°C with fan. Thus you can power your medical device in a quiet and hygienic way as you don't need to run a fan to cool down the power supply. High reliability is provided by use of industrial quality grade components and an excellent thermal management. It makes the products an ideal solution for medical devices and for demanding safety and space critical applications.

### Models

Order Code	Output Power max.	Output Voltage nom. (adjustable)	Output Current max.	Efficiency typ.
TPP 450-112B-M	450 W	12 VDC (11.0 - 13.0 VDC)	37'500 mA	91 %
TPP 450-115B-M		15 VDC (13.8 - 16.2 VDC)	30'000 mA	92 %
TPP 450-124B-M		24 VDC (22.1 - 25.9 VDC)	18'750 mA	93 %
TPP 450-128B-M		28 VDC (25.8 - 30.2 VDC)	16'100 mA	93 %
TPP 450-136B-M		36 VDC (33.1 - 38.9 VDC)	12'500 mA	93 %
TPP 450-148B-M		48 VDC (44.2 - 51.8 VDC)	9'400 mA	94 %
TPP 450-153B-M		53 VDC (48.8 - 57.2 VDC)	8'550 mA	94 %

### Options

TPP 450-AUX1	- Optional Cable for auxiliary connection (2 x 4 pin): <a href="http://www.tracopower.com/products/tpp450-aux1.pdf">www.tracopower.com/products/tpp450-aux1.pdf</a>
on demand (backorder with MOQ non stocking item)	- Optional version with fan on top

### Input Specifications

Input Voltage	- AC Range	Operational Range: <b>85 - 264 VAC</b> (Full Range) Rated Range: <b>100 - 240 VAC</b> (Full Range)
	- DC Range	Operational Range: <b>120 - 370 VDC</b> (Designed for, no certification) Polarity: <b>+DC: L / -DC: N</b>
Input Frequency		<b>47 - 63 Hz</b>
Input Current	- Full Load & $V_{in} = 230$ VAC	<b>2'400 mA max.</b>
	- Full Load & $V_{in} = 115$ VAC	<b>5'800 mA max.</b>
Power Consumption	- At no load	<b>800 mW max.</b>
Input Inrush Current	- At 230 VAC	<b>100 A max.</b>
Power Factor	- At 230 VAC	<b>0.95 min.</b> (Active Power Factor Correction)
	- At 115 VAC	<b>0.95 min.</b> (Active Power Factor Correction)
Input Protection		<b>T 6.3 A / 250 VAC</b> (Internal Fuse in L & N)
Recommended Input Fuse		(The need of an external fuse has to be assessed in the final application.)

### Output Specifications

Output Voltage Adjustment		<b>±8%</b> (By trim potentiometer) Output power must not exceed rated power!
Voltage Set Accuracy		<b>±1% max.</b>
Regulation	- Input Variation ( $V_{min} - V_{max}$ )	<b>0.2% max.</b>
	- Load Variation (0 - 100%)	<b>0.5% max.</b>
Ripple and Noise (20 MHz Bandwidth)	12 VDC model:	<b>250 mVp-p typ.</b> (w/ 1 $\mu$ F X7R)
	15 VDC model:	<b>300 mVp-p typ.</b> (w/ 1 $\mu$ F X7R)
	24 VDC model:	<b>240 mVp-p typ.</b> (w/ 1 $\mu$ F X7R)
	28 VDC model:	<b>280 mVp-p typ.</b> (w/ 1 $\mu$ F X7R)
	36 VDC model:	<b>360 mVp-p typ.</b> (w/ 1 $\mu$ F X7R)
	48 VDC model:	<b>480 mVp-p typ.</b> (w/ 1 $\mu$ F X7R)
Capacitive Load	53 VDC model:	<b>530 mVp-p typ.</b> (w/ 0.1 $\mu$ F X7R)
	12 VDC model:	<b>31'250 <math>\mu</math>F max.</b>
	15 VDC model:	<b>20'000 <math>\mu</math>F max.</b>
	24 VDC model:	<b>7'820 <math>\mu</math>F max.</b>
	28 VDC model:	<b>5'750 <math>\mu</math>F max.</b>
Minimum Load	36 VDC model:	<b>3'500 <math>\mu</math>F max.</b>
	48 VDC model:	<b>1'960 <math>\mu</math>F max.</b>
	53 VDC model:	<b>1'600 <math>\mu</math>F max.</b>
Temperature Coefficient		<b>±0.02 %/K max.</b>
Hold-up Time	- At 230 VAC	<b>12 ms min.</b>
	- At 115 VAC	<b>12 ms min.</b>
Start-up Time	- At 230 VAC	<b>2'000 ms max.</b>
	- At 115 VAC	<b>2'000 ms max.</b>
Short Circuit Protection		<b>Continuous, Automatic recovery</b> (Level 1, nom.) <b>Latch</b> (Level 2, instantaneous high current)
Output Current Limitation		<b>115 - 155% of I<sub>out</sub> max.</b>
Overvoltage Protection		<b>110 - 135% of V<sub>out</sub> nom.</b> (Latch off, Standby Power Source always present)
Transient Response	- Response Deviation	<b>3% max.</b> (50% to 75% Load Step)
	- Response Time	<b>600 <math>\mu</math>s typ.</b> (50% to 75% Load Step)

All specifications valid at nominal voltage, resistive full load and +25°C after warm-up time, unless otherwise stated.

## Safety Specifications

Safety Standards	- IT / Multimedia Equipment	EN 62368-1 IEC 62368-1 UL 62368-1
	- Railway Fire Protection	EN 45545-2
	- Medical Equipment	EN 60601-1 IEC 60601-1 ANSI/AAMI ES 60601-1
	- Certification Documents	2 x MOPP (Means Of Patient Protection) <a href="http://www.tracopower.com/overview/tpp450b-m">www.tracopower.com/overview/tpp450b-m</a>
Protection Class		Class I & II (Prepared): Reinforced Insulation
Pollution Degree		PD 2
Over Voltage Category		OVC II

## EMC Specifications

EMI Emissions	- Conducted Emissions	EN 60601-1-2 edition 4 (Medical Devices) EN 55011 class B (internal filter) EN 55032 class B (internal filter)
	- Radiated Emissions	EN 55011 class A (internal filter) EN 55032 class A (internal filter)
	- Harmonic Current Emissions	EN 61000-3-2, class A EN 61000-3-2, class D
	- Voltage Fluctuations & Flicker	EN 61000-3-3 (For optimal EMI performance the power supply should be mounted to a grounded aluminium plate (480 x 248 x 12 mm) with electrical contact to the four PCB mounting holes. To comply with safety standards, this plate must be grounded.)
EMS Immunity	- Electrostatic Discharge	EN 55024 (IT Equipment) EN 60601-1-2 edition 4 (Medical Devices) Air: EN 61000-4-2, $\pm 15$ kV, perf. criteria A Contact: EN 61000-4-2, $\pm 8$ kV, perf. criteria A
	- RF Electromagnetic Field	EN 61000-4-3, 3 V/m, perf. criteria A
	- EFT (Burst) / Surge	EN 61000-4-4, $\pm 2$ kV, perf. criteria A L to L: EN 61000-4-5, $\pm 1$ kV, perf. criteria A L to PE: EN 61000-4-5, $\pm 2$ kV, perf. criteria A
	- Conducted RF Disturbances	EN 61000-4-6, 20 Vrms, perf. criteria A
	- PF Magnetic Field	Continuous: EN 61000-4-8, 30 A/m, perf. criteria A
	- Voltage Dips & Interruptions	230 VAC / 50 Hz: EN 61000-4-11 30%, 25 periods, perf. criteria A >95%, 0.5 periods, perf. criteria A >95%, 1 period, perf. criteria A >95%, 250 periods, perf. criteria B
		115 VAC / 60 Hz: EN 61000-4-11 30%, 25 periods, perf. criteria A >95%, 0.5 periods, perf. criteria A >95%, 1 period, perf. criteria A >95%, 250 periods, perf. criteria B

## General Specifications

Relative Humidity		95% max. (non condensing)
Temperature Ranges	- Operating Temperature	-40°C to +80°C
	- Storage Temperature	-40°C to +80°C
Power Derating	- High Temperature	See application note: <a href="http://www.tracopower.com/overview/tpp450b-m">www.tracopower.com/overview/tpp450b-m</a>
	- Low Input Voltage	1.33 %/V below 100 VAC

All specifications valid at nominal voltage, resistive full load and +25°C after warm-up time, unless otherwise stated.

Over Temperature Protection Switch Off	- Protection Mode - Measurement Point	See application note: <a href="http://www.tracopower.com/overview/tpp450b-m">www.tracopower.com/overview/tpp450b-m</a>	110°C to 125°C (Latch off) (Standby Power Source always present)
Cooling System			<b>Forced air cooling</b> (with internal fan)
Fan Power Source	- Characteristic - Output Voltage - Output Current		<b>Variable fan speed</b> (temperature regulated) 12 VDC 500 mA max.
Standby Power Source	- Output Voltage - Output Current		5 VDC 2000 mA max.
Remote Control	- Voltage Controlled Remote  - Remote Pin Input Current		On: 3.0 to 12 VDC or open circuit Off: 0 to 1.2 VDC or short circuit Refers to '+Remote' and '-Remote' Pin -0.5 to 1.0 mA (Standby power source is always present)
Altitude During Operation			5'000 m max.
Switching Frequency			55 - 85 kHz (PFM)
Insulation System			Reinforced Insulation
Working Voltage (rated)			312 VAC
Isolation Test Voltage	- Input to Output, 60 s - Input to Case or PE, 60 s - Output to Case or PE, 60 s		4'000 VAC 2'500 VAC 2'500 VAC
Isolation Resistance	- Input to Output, 500 VDC		100 MΩ min.
Leakage Current (at 264 VAC)	- Touch Current		100 μA max.
Reliability	- Calculated MTBF		410'000 h (MIL-HDBK-217F, ground benign)
Environment	- Vibration - Mechanical Shock		IEC 60068-2-6 IEC 60068-2-27
Housing Material			Stainless Steel (Cover)
Housing Type			Metal Case
Mounting Type			Chassis Mount
Connection Type			Pin Connector
Weight			552 g
Power OK Signal	- Trigger Threshold  - Power OK - Power Off  - Pin Specifications	12 VDC model: 15 VDC model: 24 VDC model: 28 VDC model: 36 VDC model: 48 VDC model: 53 VDC model:	Open collector output 9.8 - 11 VDC 12.3 - 13.8 VDC 19.7 - 22.1 VDC 23 - 25.8 VDC 29.5 - 33.1 VDC 39.4 - 44.2 VDC 43.5 - 48.8 VDC Low level High resistance (Refers to 'PG' and '-Vout' Pin) 50 VDC / 50 mA / 120 mW max.
Sense Function			8% max. of Vout nom.  (If sense function is not used, sense pins should be connected to output pins.)

All specifications valid at nominal voltage, resistive full load and +25°C after warm-up time, unless otherwise stated.

Environmental Compliance - REACH Declaration

[www.tracopower.com/info/reach-declaration.pdf](http://www.tracopower.com/info/reach-declaration.pdf)

REACH SVHC list compliant

REACH Annex XVII compliant

- RoHS Declaration

[www.tracopower.com/info/rohs-declaration.pdf](http://www.tracopower.com/info/rohs-declaration.pdf)

Exemptions: 7a, 7c-I

(RoHS exemptions refer to the component concentration only, not to the overall concentration in the product (O5A rule). The SCIP number is provided on request.)

- Flammability (EN 45545-2)

[www.tracopower.com/info/en45545-declaration.pdf](http://www.tracopower.com/info/en45545-declaration.pdf)

### Supporting Documents

Overview Link (for additional Documents)

[www.tracopower.com/overview/tpp450b-m](http://www.tracopower.com/overview/tpp450b-m)

### Outline Dimensions

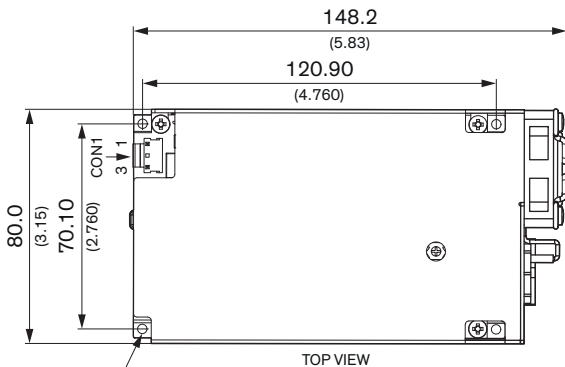

4-Ø3.2 (0.13) holes

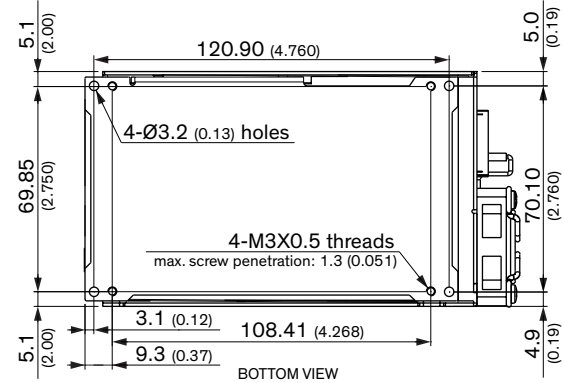
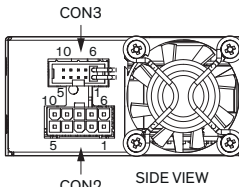
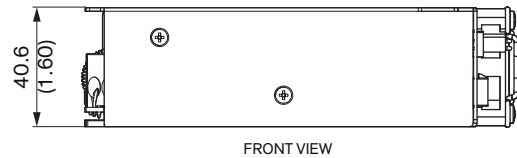

Max. screw penetration: 1.3 (0.05)

All dimensions in mm (inch)

FAN dimension: 40x40x10mm Air flow: 9.5 CFM  
The fan's durability is lower compared to the power supply and has only 2 years warranty.

Tolerance: X.X ±0.5 (X.XX ±0.02)  
X.XX ±0.25 (X.XXX ±0.01)  
Screw locked torque: max. 5.2 kgfcm / 0.51 Nm

Input	
CON1	
Pin	Function
1	AC (L)
3	AC (N)

Output	
CON2	
Pin*	Function
1-5	-Vout
6-10	+Vout

Auxiliary	
CON3	
Pin	Function
1	+Fan
2	+Sense
3	+Remote
4	PG
5	+Standby
6	-Fan**
7	-Sense
8	-Remote**
9	No Pin
10	-Standby**

\*Terminal rated for 13 A max. (at higher current connection has to be split)

**CON1:**  
Molex housing: 09-50-8031  
Molex crimp terminals: 2478,6838,45570

**CON2:**  
Molex housing: 39-01-2105  
Molex crimp terminals: 5556,45750

**CON3:**  
Molex housing: 90143-0010  
Molex crimp terminals: 90119

\*\*Internally connected with -Vout

All specifications valid at nominal voltage, resistive full load and +25°C after warm-up time, unless otherwise stated.

### Optional version with fan on top

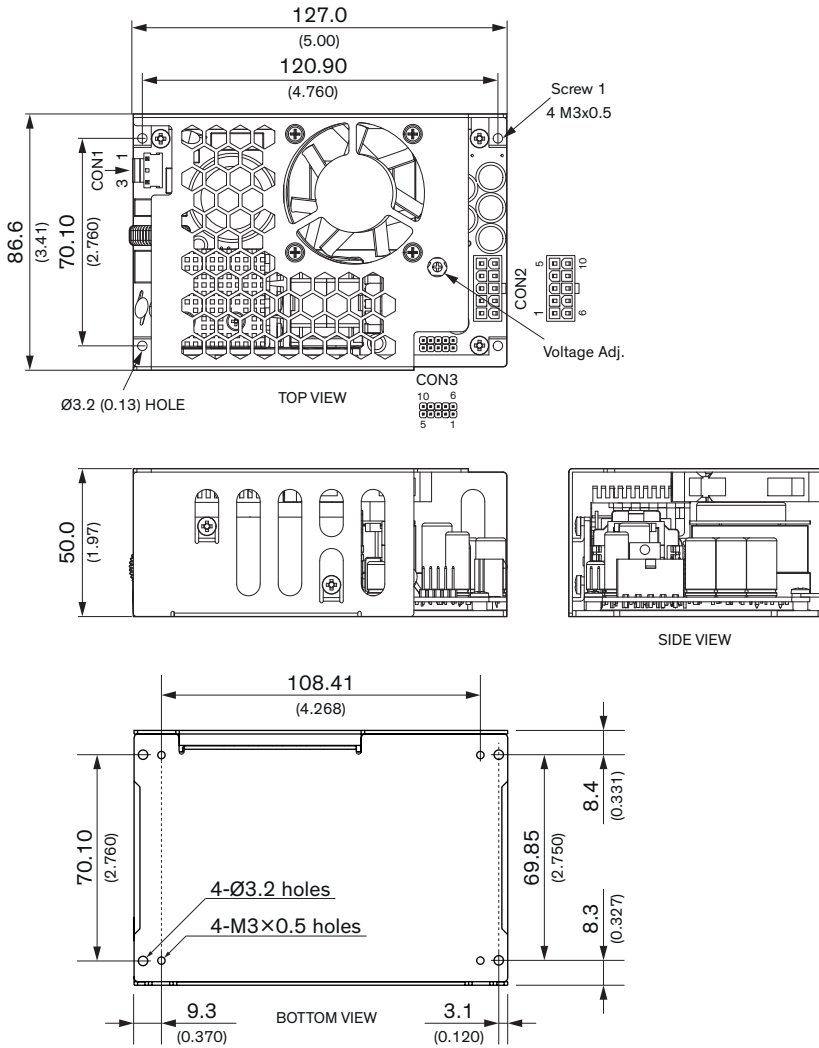

Max. screw penetration: 1.3 (0.05)

FAN dimension: 40×40×10mm Air flow: 9.5 CFM  
The fan's durability is lower compared to the power supply and has only 2 years warranty.

All dimensions in mm (inch)

Tolerance: X.X ±0.5 (X.XX ±0.02)

X.XX ±0.25 (X.XXX ±0.01)

Screw locked torque: max. 5.2 kgfcm / 0.51 Nm

Input	
CON1	
Pin	Function
1	AC (L)
3	AC (N)

Output	
CON2	
Pin*	Function
1-5	+Vout
6-10	-Vout

Auxiliary	
CON3	
Pin	Function
1	+Fan
2	+Sense
3	+Remote
4	PG
5	+Standby
6	-Fan**
7	-Sense
8	-Remote**
9	No Pin
10	-Standby**

\*Terminal rated for 13 A max. (at higher current connection has to be split)

**CON1:**  
Molex housing:  
09-50-8031  
Molex crimp terminals:  
2478,6838,45570

**CON2:**  
Molex housing:  
39-01-2105  
Molex crimp terminals:  
5556,45750

**CON3:**  
Molex housing:  
90143-0010  
Molex crimp terminals:  
90119

\*\*Internally connected with -Vout

## X-ON Electronics

Largest Supplier of Electrical and Electronic Components

*Click to view similar products for [Switching Power Supplies](#) category:*

*Click to view products by [TRACO Power](#) manufacturer:*

Other Similar products are found below :

[70841011](#) [73-551-0005](#) [73-551-0048](#) [PS3E-B12F](#) [PS3E-E12F](#) [AAD600S-4-OP](#) [R22095](#) [KD0204](#) [9021](#) [LDIN100150](#) [LPM000-BBAR-01](#)  
[LPX17S-C](#) [EVS57-10R6/R](#) [FP80](#) [FRV7000G](#) [22929](#) [PS3E-F12F](#) [CQM1IA121](#) [40370121900](#) [VI-PU22-EXX](#) [40370121910](#) [LDIN5075](#)  
[LPM615-CHAS](#) [LPX140-C](#) [09-160CFG](#) [70841025](#) [VPX3000-CBL-DC](#) [VI-LUL-IU](#) [LPM000-BBAR-05](#) [LPM000-BBAR-08](#) [LPM124-](#)  
[OUTA1-48](#) [LPM000-BBAR-07](#) [LPM109-OUTA1-10](#) [LPM616-CHAS](#) [08-30466-1055G](#) [08-30466-2175G](#) [08-30466-2125G](#) [DMB-EWG](#)  
[TVQF-1219-18S](#) [6504-226-2101](#) [CQM1IPS01](#) [SP-300-5](#) [CQM1-IPS02](#) [VI-MUL-ES](#) [22829](#) [08-30466-0065G](#) [VI-RU031-EWWX](#) [08-30466-](#)  
[0028G](#) [EP3000AC48INZ](#) [VP-C2104853](#)