

# DDR2 Unbuffered DIMM

DDR2 Unbuffered DIMM is high-speed, low power memory module that use DDR2 SDRAM in FBGA package and a 2048 bits serial EEPROM on a 240-pin printed circuit board. DDR2 Unbuffered DIMM is a Dual In-Line Memory Module and is intended for mounting into 240-pin edge connector sockets.



Synchronous design allows precise cycle control with the use of system clock. Data I/O transactions are possible on both edges of DQS. Range of operation frequencies, programmable latencies allow the same device to be useful for a variety of high bandwidth, high performance memory system applications.

## Features

- RoHS compliant products.
- JEDEC standard 1.8V ± 0.1V Power supply
- VDDQ=1.8V ± 0.1V
- Clock Freq: 200MHZ for 400Mb/s/Pin  
266MHZ for 533Mb/s/Pin.  
333MHZ for 667Mb/s/Pin.  
400MHZ for 800Mb/s/Pin.
- Programmable CAS Latency: 3,4,5,6
- Programmable Additive Latency : :0, 1, 2, 3, 4, 5
- Write Latency (WL) = Read Latency (RL)-1
- Burst Length: 4,8(Interleave/nibble sequential)
- Programmable sequential / Interleave Burst Mode
- Bi-directional Differential Data-Strobe (Single-ended data-strobe is an optional feature)
- Off-Chip Driver (OCD) Impedance Adjustment
- MRS cycle with address key programs.
- On Die Termination
- Serial presence detect with EEPROM

## Pin Identification

Symbol	Function
A0~A13, BA0~BA2	Address/Bank input
DQ0~DQ63	Bi-direction data bus.
DQS0~DQS7	Data strobes
/DQS0~/DQS7	Differential Data strobes
CK0, /CK0,CK1, /CK1 CK2, /CK2	Clock Input. (Differential pair)
CKE0, CKE1	Clock Enable Input.
ODT0, ODT1	On-die termination control line
/S0, /S1	DIMM rank select lines.
/RAS	Row address strobe
/CAS	Column address strobe
/WE	Write Enable
DM0~DM7	Data masks/high data strobes
VDD	+1.8 Voltage power supply
VDDQ	+1.8 Voltage Power Supply for DQS
V <sub>REF</sub>	Power Supply for Reference
V <sub>DD</sub> SPD	SPD EEPROM power supply
SA0~SA2	Address select for EEPROM
SCL	Clock for EEPROM
SDA	Data for EEPROM
VSS	Ground
NC	No Connection

**Dimensions (Normal Profile, Unit: millimeter)**

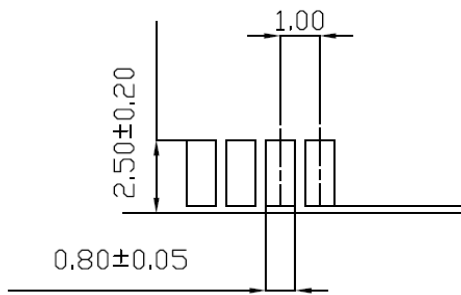
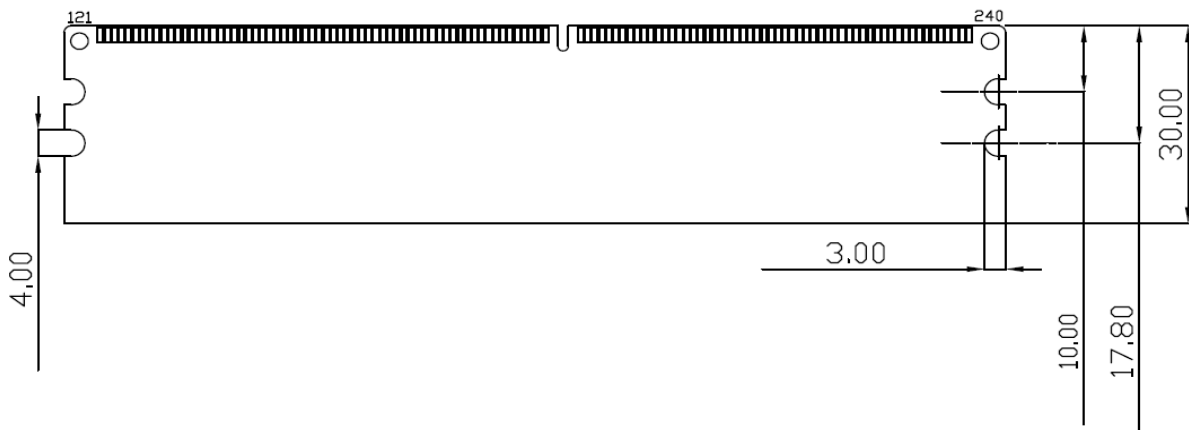
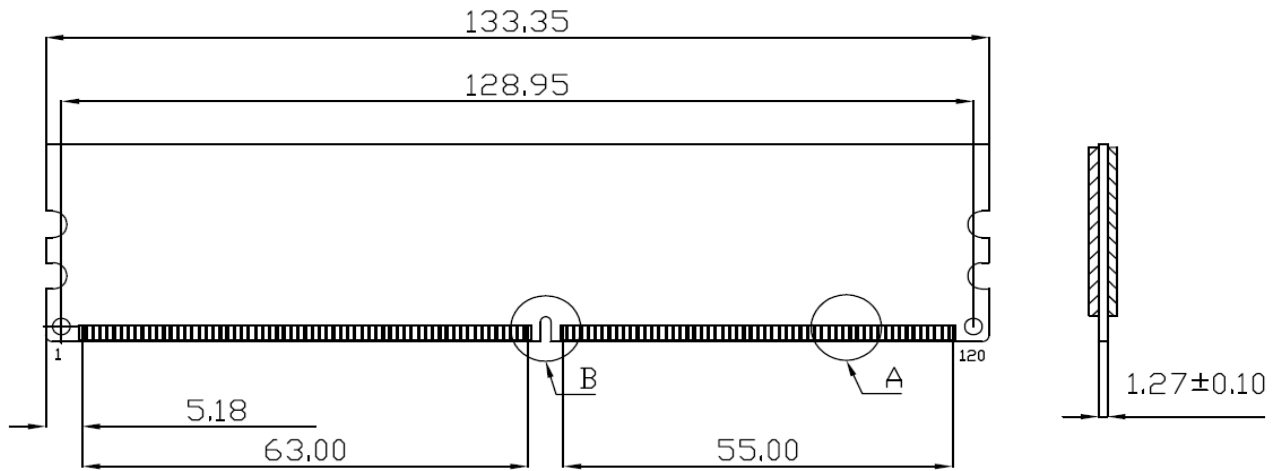

Detail A

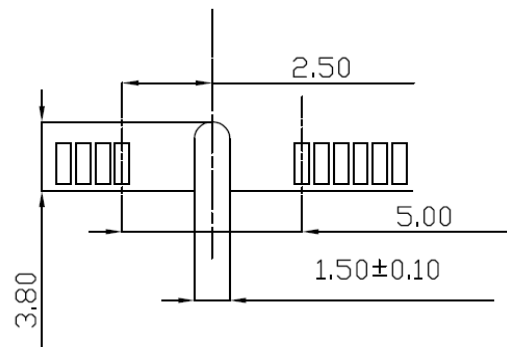

Detail B

**Note:**

1. Tolerances on all dimensions  $\pm 0.15$  mm unless otherwise specified.

**Dimensions (Very Low Profile, Unit: millimeter)**

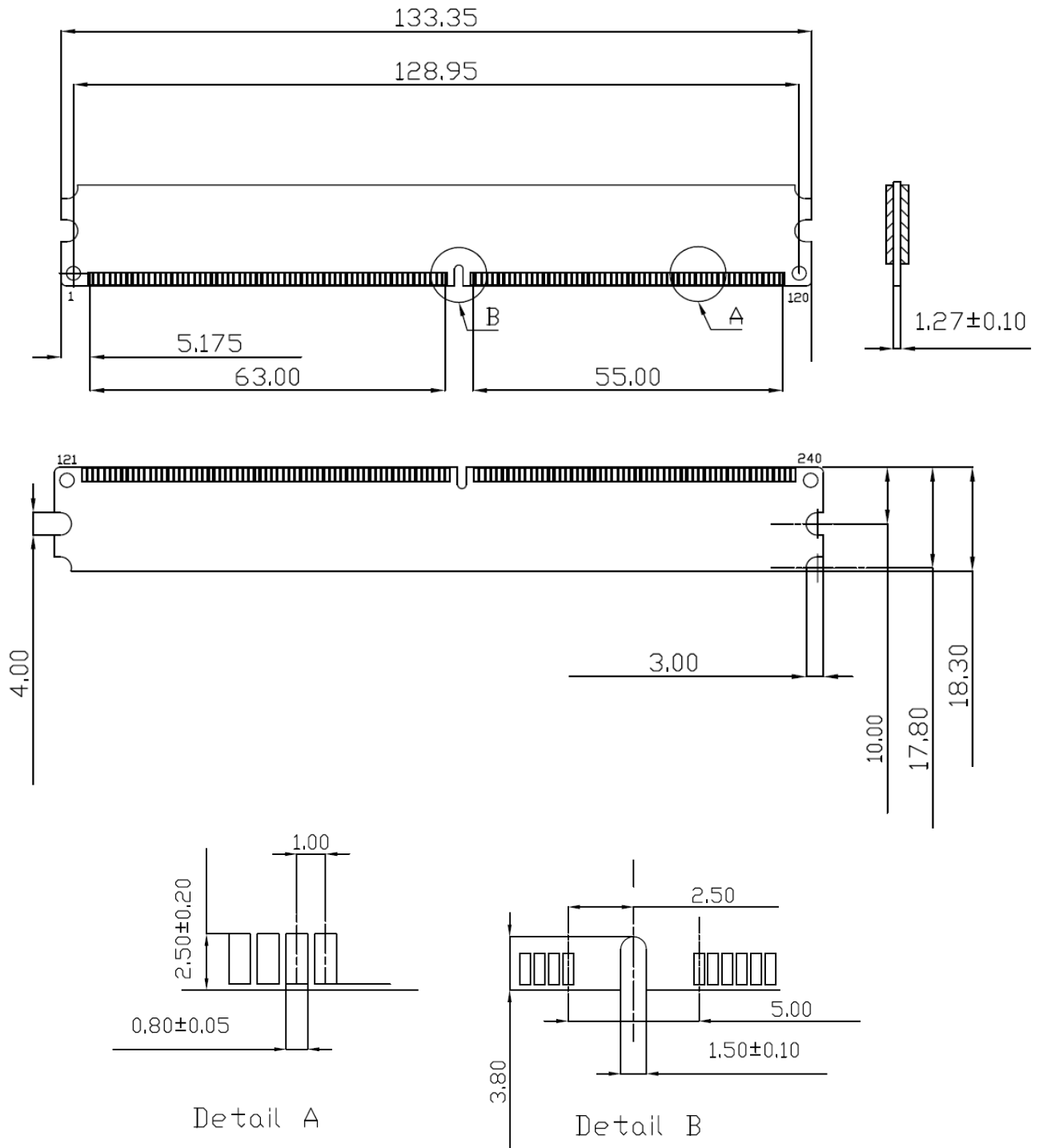

**Note:**

1. Tolerances on all dimensions +/-0.15mm unless otherwise specified.

## Pin Assignments

Pin No	Pin Name	Pin No	Pin Name	Pin No	Pin Name	Pin No	Pin Name	Pin No	Pin Name	Pin No	Pin Name
01	VREF	41	VSS	81	DQ33	121	VSS	161	NC	201	VSS
02	VSS	42	NC	82	VSS	122	DQ4	162	NC	202	DM4
03	DQ0	43	NC	83	/DQS4	123	DQ5	163	VSS	203	NC
04	DQ1	44	VSS	84	DQS4	124	VSS	164	NC	204	VSS
05	VSS	45	NC	85	VSS	125	DM0	165	NC	205	DQ38
06	/DQS0	46	NC	86	DQ34	126	NC	166	VSS	206	DQ39
07	DQS0	47	VSS	87	DQ35	127	VSS	167	NC	207	VSS
08	VSS	48	NC	88	VSS	128	DQ6	168	NC	208	DQ44
09	DQ2	49	NC	89	DQ40	129	DQ7	169	VSS	209	DQ45
10	DQ3	50	VSS	90	DQ41	130	VSS	170	VDDQ	210	VSS
11	VSS	51	VDDQ	91	VSS	131	DQ12	171	CKE1	211	DM5
12	DQ8	52	CKE0	92	/DQS5	132	DQ13	172	VDD	212	NC
13	DQ9	53	VDD	93	DQS5	133	VSS	173	NC	213	VSS
14	VSS	54	BA2	94	VSS	134	DM1	174	NC	214	DQ46
15	/DQS1	55	NC	95	DQ42	135	NC	175	VDDQ	215	DQ47
16	DQS1	56	VDDQ	96	DQ43	136	VSS	176	A12	216	VSS
17	VSS	57	A11	97	VSS	137	CK1	177	A9	217	DQ52
18	NC	58	A7	98	DQ48	138	/CK1	178	VDD	218	DQ53
19	NC	59	VDD	99	DQ49	139	VSS	179	A8	219	VSS
20	VSS	60	A5	100	VSS	140	DQ14	180	A6	220	CK2
21	DQ10	61	A4	101	SA2	141	DQ15	181	VDDQ	221	/CK2
22	DQ11	62	VDDQ	102	NC	142	VSS	182	A3	222	VSS
23	VSS	63	A2	103	VSS	143	DQ20	183	A1	223	DM6
24	DQ16	64	VDD	104	/DQS6	144	DQ21	184	VDD	224	NC
25	DQ17	65	VSS	105	DQS6	145	VSS	185	CK0	225	VSS
26	VSS	66	VSS	106	VSS	146	DM2	186	/CK0	226	DQ54
27	/DQS2	67	VDD	107	DQ50	147	NC	187	VDD	227	DQ55
28	DQS2	68	NC	108	DQ51	148	VSS	188	A0	228	VSS
29	VSS	69	VDD	109	VSS	149	DQ22	189	VDD	229	DQ60
30	DQ18	70	A10/AP	110	DQ56	150	DQ23	190	BA1	230	DQ61
31	DQ19	71	BA0	111	DQ57	151	VSS	191	VDDQ	231	VSS
32	VSS	72	VDDQ	112	VSS	152	DQ28	192	/RAS	232	DM7
33	DQ24	73	/WE	113	/DQS7	153	DQ29	193	/CS0	233	NC
34	DQ25	74	/CAS	114	DQS7	154	VSS	194	VDDQ	234	VSS
35	VSS	75	VDDQ	115	VSS	155	DM3	195	ODT0	235	DQ62
36	/DQS3	76	/CS1	116	DQ58	156	NC	196	A13	236	DQ63
37	DQS3	77	ODT1	117	DQ59	157	VSS	197	VDD	237	VSS
38	VSS	78	VDDQ	118	VSS	158	DQ30	198	VSS	238	VDDSPD
39	DQ26	79	VSS	119	SDA	159	DQ31	199	DQ36	239	SA0
40	DQ27	80	DQ32	120	SCL	160	VSS	200	DQ37	240	SA1

## **X-ON Electronics**

Largest Supplier of Electrical and Electronic Components

*Click to view similar products for [transcend](#) manufacturer:*

Other Similar products are found below :

[TS16GSDHC10](#) [TS25S42MAR00IMI](#) [TS128MSQ64V8W](#) [TS256MLQ64V8U](#) [TS51S42MAR00IMI](#) [TS12S57MAR00IM1](#)  
[TS64M7MAR00IS1](#) [TS51S42MAR02IM1](#) [TS25S42MAR02IM1](#) [TS64S51MAR02IM1](#) [TS32M7MAR00IS1](#) [TS32GSDHC10](#)