

A-11J

Description:

Triad's **A-11J** Input Transformer provides the durability and precision required in today's demanding designs. **Mu-Metal case** construction for magnetic field immunity and 60 to 80 dB Hum reduction. **Large step-up turns ratio** to couple low-level input signals to the grid of the first amplifier tube or, in a multistage system, to the input element of the first transistor amplifier. Low level **High Fidelity** with excellent Unwanted **Noise reduction**. Applications include signal pre-amplification, inter-stage isolation, signal level step up/down, and impedance matching.

Electrical Specifications (@25C)

Power level (mW)	Inductance (H) pri	Impedance		DCR (Ω)		Turns Ratio	DWV
		Pri	Sec	Pri	Sec		
10	7 Min	50	60k	50	5000	1:28	500V
		250				1:15	
		600				1:10	

PARAMETER	CONDITIONS	TYPICAL
Frequency Range		20 Hz – 20KHZ
Gain	1kHz, Rs = 600 Ω RL = 60kΩ	+13.1 dB
Distortion (THD+N%)	1kHz, +8dBu input, Rs = 600 Ω RL = 60kΩ	0.007%
	1kHz, +2dBu input, Rs = 600 Ω RL = 60kΩ	0.006%
	1kHz, -4dBu input, Rs = 600 Ω RL = 60kΩ	0.005%
Max input level (20Hz)	1% THD + N%, Rs=600Ω, RL = 60kΩ	-1.5 dBu
Frequency response (1 kHz Ref.)	20 Hz, RS=600Ω, RL=60kΩ	-0.56dB
	20kHz, RS=600Ω, RL=60kΩ	-1.26dB
Phase Shift @ 20Hz	Reference to source generator Rs= 600Ω, RL = 60kΩ	+39°
Phase shift @ 20kHz		-8°
CMRR	60 Hz	90 dB
	1 kHz	78 dB
Temperature Rating	Operation & Storage	0°C to 70°C

RoHS Compliance: As of manufacturing date February 2005, all standard products meet the requirements of 2011/65/EU, known as the RoHS initiative.

*Upon printing, this document is considered "uncontrolled". Please contact Triad Magnetics for the most current version.



For illustration purpose only

ALL LEADS = 6.0" Min

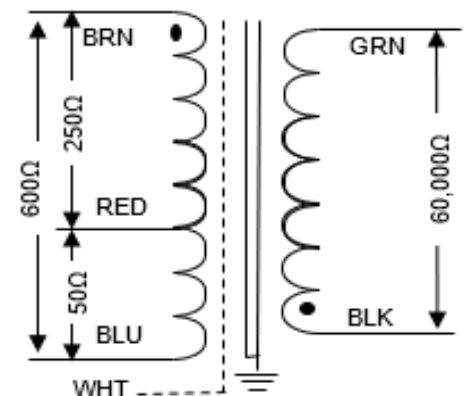
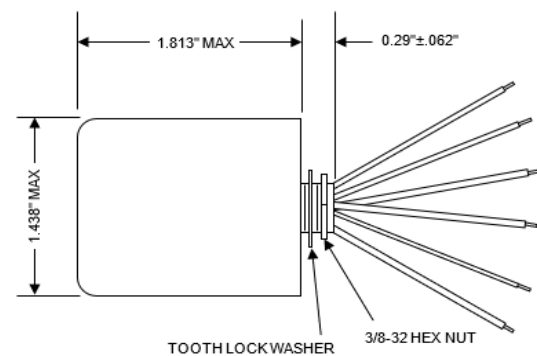

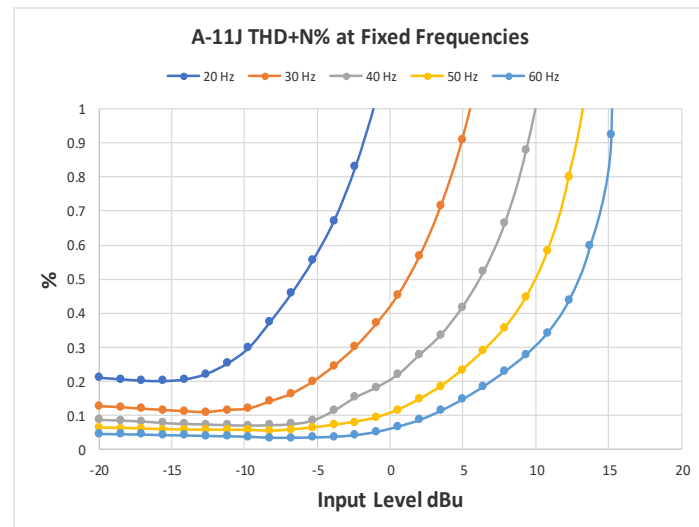
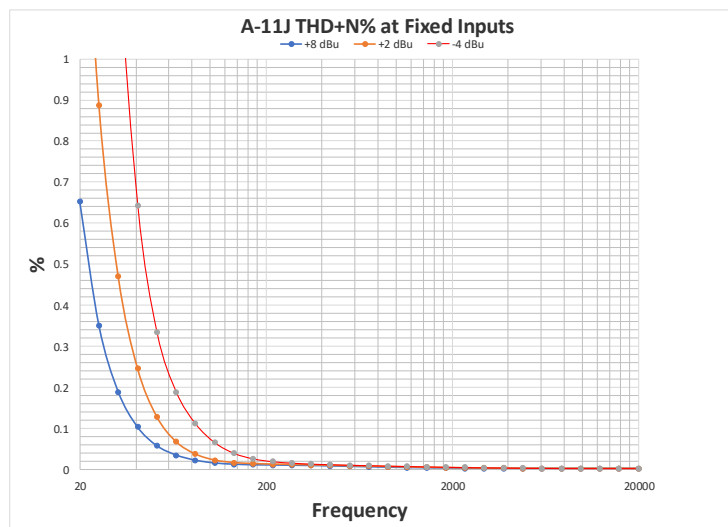
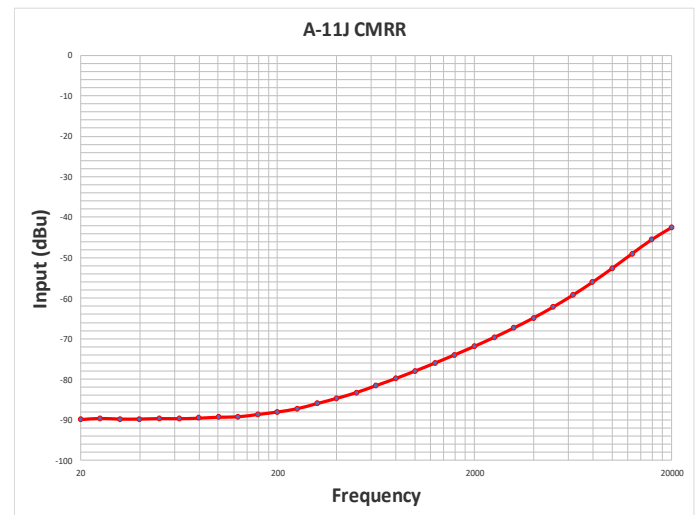
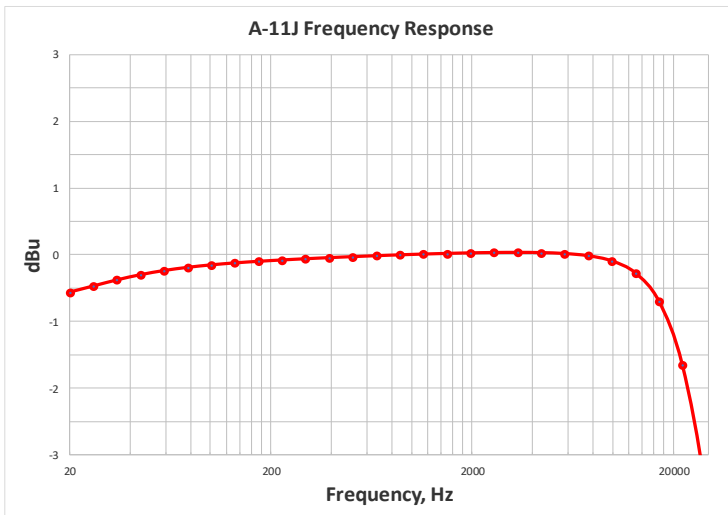
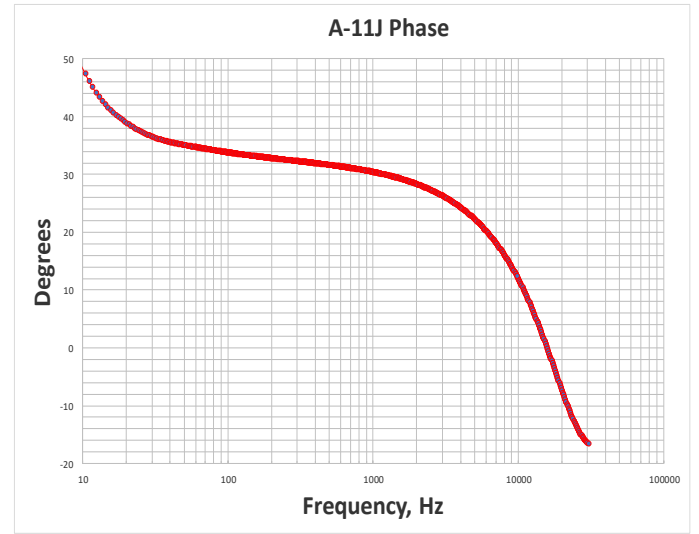
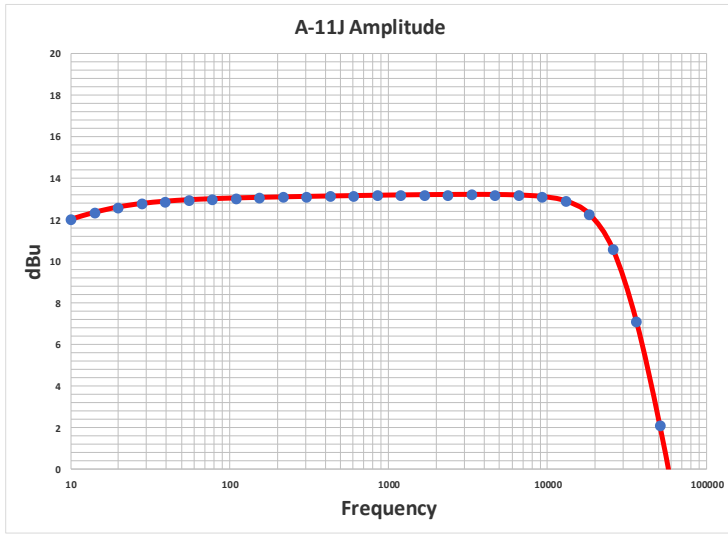

NOTE: Graph data was taken on a random sample using an Audio Precision Model APX555 Audio Analyzer.

X-ON Electronics

Largest Supplier of Electrical and Electronic Components

Click to view similar products for [Audio Transformers](#) / [Signal Transformers](#) category:

Click to view products by [Triad](#) manufacturer:

Other Similar products are found below :

[CU4S0506AT-2655-H1](#) [MGPWT-00449-P](#) [PE-64961](#) [1812WBT2-4](#) [BX1194WNL](#) [1879479-1](#) [PA1528ANL](#) [T1137NLT](#) [PE-65848FNLT](#)
[H5019EFNL](#) [CX2045ALNLT](#) [TG1G-E201NV6LF](#) [MGPWT-00059-P](#) [MGPWT-00266-P](#) [MGPWT-00278-P](#) [MGPWT-00431-P](#) [TTC-100](#)
[TTC-143-H](#) [TTC-5032-1](#) [4-1879391-0](#) [100213](#) [T1142NL](#) [TG1G-S001NZLF](#) [T1124NL](#) [1879732-1](#) [2-1879391-5](#) [MABA-010321-CT1A42](#)
[TX1341NL](#) [H0013FNL](#) [H5020FNL](#) [H2009FNLT](#) [H5004NLT](#) [S553-5999-52-F](#) [SCMS7D43AY100PT1](#) [T5008NLT](#) [PE-68517T](#) [MGPWT-](#)
[00339-P](#) [H5014FNLT](#) [TX1473NLT](#) [PE-69011NLT](#) [CX2043LNLT](#) [H7137FNLT](#) [H1259NLT](#) [TX1344NLT](#) [LM-LP-1005L](#) [H0013NLT](#)
[S558-5500-JV](#) [TX1193NLT](#) [T7015NL](#) [T1124NLT](#)