

Driver LCBU 10W 12V basic phase-cut SR
basic series

Product description

- Dimmable via leading-edge and trailing-edge phase dimmer
- Dimming range typ. 5 to 100 % (depending on dimmer)
- Type of protection IP20
- Screw terminals
- Connecting cable, wire cross-section 0.5 – 2.5 mm²
- SELV
- 12 V DC output voltage
- Output power 10 W
- Nominal life of 50,000 h (at ta max. 50 °C with a failure rate of max. 0.2 % per 1,000 h)
- 5 years guarantee (conditions at www.tridonic.com)



Properties

- Casing: polycarbonat, white
- Compact dimensions
- Overload protection
- Short-circuit protection
- No-load protection



Standards, page 3

Wiring diagrams and installation examples, page 3

IP20 SELV      

Driver LCBU 10W 12V basic phase-cut SR basic series

Technical data

Rated supply voltage	220 – 240 V
AC voltage range	198 – 264 V
Mains frequency	50 / 60 Hz
Typ. rated current (at 230 V, 50 Hz, full load)	0.06 A
λ at full load ^①	0.9
λ at min. load ^①	0.7
Typ. current ripple (at 230 V, 50 Hz, full load)	± 30 %
Output P_{STLM} (at full load)	≤ 1
Output SVM (at full load)	≤ 0.4
Starting time (at 230 V, 50 Hz, full load)	≤ 0.1 s
Turn off time (at 230 V, 50 Hz, full load)	≤ 0.1 s
Hold on time at power failure (output)	0 s
Ambient temperature t_a	-25 ... +50 °C
Ambient temperature t_a (at lifetime 50,000 h)	50 °C
Max. casing temperature t_c	75 °C
Storage temperature t_s	-40 ... +85 °C
Lifetime	up to 50,000 h
Guarantee (conditions at www.tridonic.com)	5 years
Dimensions L x W x H	102 x 51 x 30 mm

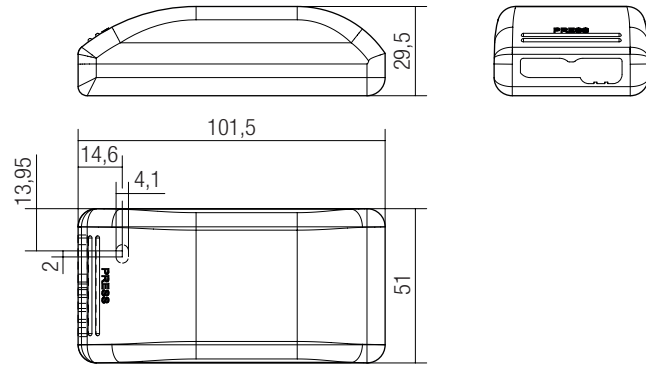

Ordering data

Type	Article number	Packaging, carton	Packaging, pallet	Weight per pc.
LCBU 10W 12V basic phase-cut SR	89800289	20 pc(s).	1,000 pc(s).	0.065 kg

Specific technical data

Type	Efficiency at full load ^①	Efficiency at min. load ^①	Max. output current	Output voltage DC	Max. output voltage DC	Max. input power	Output power
LCBU 10W 12V basic phase-cut SR	77 %	65 %	0.83 A	11 – 15 V	15 V	13 W	3 – 10 W

^① Test result at 230 V, 50 Hz.

1. Standards

EN 55015
EN 61000-3-2
EN 61000-3-3
EN 61347-1
EN 61347-2-13
EN 61547
EN 62384

1.1 Glow wire test

according to EN 60598-1 with increased temperature of 850 °C passed.

2. Installation / wiring

2.1 Circuit diagram

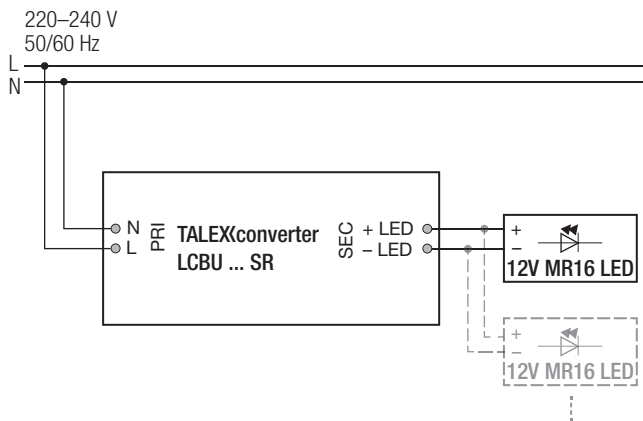

2.2 Wiring type and cross section

The wiring can be in stranded wires with ferrules or solid. For perfect function of the cage clamp terminals the strip length should be 4 – 5 mm for the input terminal.

The max. torque at the clamping screw (M3) is 0.2 Nm.

Input terminal (D2)

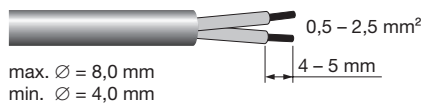

Output terminal (D1)

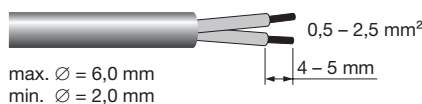

To get a proper working strain relief it is recommended that the cable jacket diameter of the side D2 is compared to the side D1 terminal according to the value table. (This can vary if the used cable jacket material varies from side D2 to D1 in pinching property).

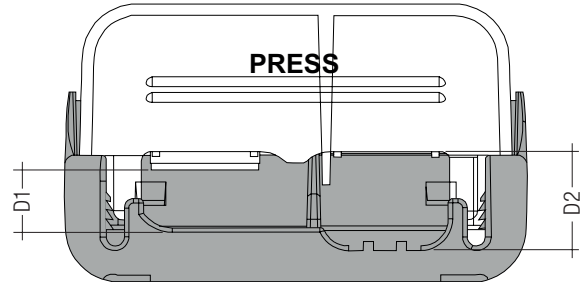

Depending on the used flaps of the terminal following cable jacket diameter difference between the side D2 and D1 terminals is recommended:

Side D1		Side D2		Difference D2 - D1
With flap	Without flap	With flap	Without flap	
x	-	-	x	4 mm
-	x	-	x	2 mm
x	-	x	-	2 mm
-	x	x	-	0 mm

2.3 Wiring instructions

The secondary leads should be separated from the mains connections and wiring for good EMC performance.

Maximum lead length on secondary side is 3 x 2 m (parallel wiring of 12 V modules). For a good EMC performance keep the the LED wiring as short as possible.

To comply with the EMC regulations run the secondary wires (LED module) in parallel.

Through wiring is not possible.

To avoid the damage of the Driver, the wiring must be protected against short circuits to earth (sharp edged metal parts, metal cable clips, louver, etc.).

2.4 Compatibility between LED driver and light source

The compatibility between LED driver and light source should be strictly checked in advance in a test.

2.5 Fixing conditions when using as independent Driver

Dry, acidfree, oilfree, fatfree. It is not allowed to exceed the maximum ambient temperature (t_a) stated on the device. Minimum distances stated below are recommendations and depend on the actual luminaire. Device is not suitable for fixing in corner.

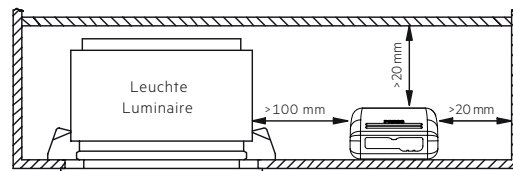

3. Electrical values

3.1 Maximum loading of automatic circuit breakers in relation to inrush current

Automatic circuit breaker type	C10	C13	C16	C20	B10	B13	B16	B20	Inrush current	
									I_{max}	Time
Installation Ø	1.5 mm ²	1.5 mm ²	1.5 mm ²	2.5 mm ²	1.5 mm ²	1.5 mm ²	1.5 mm ²	2.5 mm ²	1.7 A	40 µs
LCBU 10W 12V basic phase-cut SR	50	65	80	100	50	65	80	100		

These are max. values calculated out of inrush current! Please consider not to exceed the maximum rated continuous current of the circuit breaker. Calculation uses typical values from ABB series S200 as a reference. Actual values may differ due to used circuit breaker types and installation environment.

4. Functions

4.1 Overload protection

If the maximum load is exceeded by a defined internal limit, the LED driver reduces the LED output current. After elimination of the overload the nominal operation is restored automatically.

4.2 Short-circuit behaviour

In case of a short circuit on the secondary side (LED) the LED driver switches into hic-cup mode. After the removal of the short-circuit fault the LED driver will recover automatically.

4.3 No-load operation

The LED driver works in constant current mode. In no-load operation there is the max. output voltage at the output (see page 1).

5.3 Maximum number of switching cycles

All LED driver are tested with 50,000 switching cycles.

5.4 Additional information

Additional technical information at www.tridonic.com → Technical Data

Lifetime declarations are informative and represent no warranty claim. No warranty if device was opened.

5. Miscellaneous

5.1 Insulation and electric strength testing of luminaires

Electronic devices can be damaged by high voltage. This has to be considered during the routine testing of the luminaires in production.

According to IEC 60598-1 Annex Q (informative only!) or ENEC 303-Annex A, each luminaire should be submitted to an insulation test with 500 V_{DC} for 1 second. This test voltage should be connected between the interconnected phase and neutral terminals and the earth terminal. The insulation resistance must be at least 2 MΩ.

As an alternative, IEC 60598-1 Annex Q describes a test of the electrical strength with 1500 V_{AC} (or 1.414 x 1500 V_{DC}). To avoid damage to the electronic devices this test must not be conducted.

5.2 Installation instructions

Note the requirements set out in the document [LED_driver_installation_advise.pdf](http://www.tridonic.com/com/en/technical-docs.asp) (<http://www.tridonic.com/com/en/technical-docs.asp>).

Hot plug-in or secondary switching of LEDs is not permitted and may cause a very high current to the LEDs.

The LED driver is declared as inbuilt LED controlgear, meaning it is intended to be used within a luminaire enclosure. If the product is used outside a luminaire, the installation must provide suitable protection for people and environment (e.g. in illuminated ceilings).

X-ON Electronics

Largest Supplier of Electrical and Electronic Components

Click to view similar products for [LED Power Supplies](#) category:

Click to view products by [Tridonic](#) manufacturer:

Other Similar products are found below :

[ESS015W-1000-12](#) [PDA-WIFI](#) [PIFC-K250F](#) [PITB-K222A](#) [ALD-514012PJ134](#) [LB240S24KH](#) [LMH020-SPLC-0000-0000001](#) [79534](#) [79535](#)
[EUG-200S210DT](#) [ESS030W-1050-21](#) [ESS030W-0900-32](#) [BPOXL 4-12-035](#) [ESS010W-0350-24](#) [ESM060W-1400-42](#) [PDA080B-1A0G](#)
[PDA150B-S1A5G](#) [SLM140W-1.05-130-ZA](#) [ESS015W-0700-18](#) [EUD-150S350DVA](#) [LWA320-C420-ARK-B](#) [HVG-240-48AB](#) [HVG-320-36AB](#) [HVG-320-54AB](#) [ELG-240-C1400AB](#) [EUK-150S105DV](#) [BXCS-12Z-N2P-B1-A](#) [BXPR-WN-01-A](#) [BXCS-12D-N2P-01-A](#) [BXCS-12W-N2P-01-A](#) [LC 50W 200-350ML 170V FLEXC LP SNC4](#) [LC 25W 200-350ML 70V FLEXC LP SNC4](#) [LC 35W 200-350ML 121V FLEXC LP SNC4](#) [LC 10W 250MA FIXC SC SNC2](#) [LC 35W 800MA FIXC SR ADV2](#) [LC 38W 900MA FIXC SR ADV2](#) [LC 34W 800MA FIXC SC ADV2](#) [LC 44W 1050MA FIXC SC ADV2](#) [LC 38W 900MA 42V FIXC SRL ADV2](#) [HVG-320-48AB](#) [CNB50W-1200-42-CAS](#) [CNB30W-0600-42-CAS](#) [LCI 100W 1400MA TEC C](#) [LCI 100W 2100MA TEC C](#) [LCI 150W 1750MA TEC C](#) [LCI 150W 2100MA TEC C](#) [87500284](#) [87500447](#) [LC 50W 1200MA FIXC SR SNC](#) [87500554](#)