



VG111

1.7 – 2.7 GHz Variable Gain Amplifier



Product Features

- 1.7 – 2.7 GHz bandwidth
- 26.6 dB Attenuation Range
- +39.5 dBm Output IP3
- +22 dBm P1dB
- Constant IP3 & P1dB over attenuation range
- Single voltage supply
- Pb-free 6mm 28-pin QFN package
- MTTF > 1000 years

Applications

- Xmit & Rcv AGC circuitry for mobile infrastructure

Product Description

The VG111 is a 1.7-2.7GHz high dynamic range variable gain amplifier (VGA) packaged in a low profile Pb-free / RoHS-compliant surface-mount leadless package that measures 6 x 6 mm square.

The +22 dBm output compression point and +39.5 dBm output intercept point of the amplifier are maintained over the entire attenuation range, making the VG111 ideal for use in transmitter and receiver AGC circuits and as a variable gain stage following an LNA in high dynamic range receiver front ends.

Superior thermal design allows the product to have a minimum MTTF rating of 1000 years at a mounting temperature of +85° C. All devices are 100% RF & DC tested and packaged on tape and reel for automated surface-mount assembly.

Functional Diagram

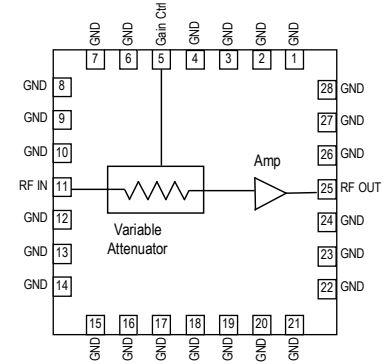

Specifications ⁽¹⁾

Parameter	Unit	Min	Typ	Max
Operational Bandwidth	MHz	1700		2700
Test Frequency ⁽¹⁾	MHz		1900	
Gain at min. attenuation	dB	12	14	
Input Return Loss	dB		12	
Output Return Loss	dB		11	
Output P1dB	dBm		+22	
Output IP3 ⁽²⁾	dBm	+37	+39.5	
Noise Figure at min. attenuation	dB		4.3	
Gain Variation Range ⁽³⁾	dB	23.5	26.6	32.5
Group Delay	ns		0.6	
Supply Voltage	V		+5	
Amplifier Current, Pin 25	mA	120	150	180
Gain Control Voltage, V _{CTRL}	V	0		4.5
Gain Control Current, V _{CTRL} =4.5V	mA			20

1. Test conditions unless otherwise noted: 25°C, V_{dd} = +5 V in a tuned application circuit. V_{ctrl} is the control voltage through a BJT transistor and a 100 Ω dropping resistor as shown in the same application circuit.
2. 3OIP measured with two tones at an output power of +5 dBm/tone separated by 10 MHz. The suppression on the largest IM3 product is used to calculate the 3OIP using a 2:1 rule.
3. The gain variation range is measured as the difference in gain with V_{ctrl} = 0V and V_{ctrl} = 4.5V at 1.9 GHz.

Typical Performance

Parameter	Units	Typical		
Frequency ⁽¹⁾	MHz	1900	2140	2600
Gain at min. attenuation	dB	14	13.3	8.1
Input Return Loss	dB	12	14	6.8
Output Return Loss	dB	11	14	10.5
Output P1dB	dBm	+22	+22	+21
Output IP3 ⁽²⁾	dBm	+39.5	+39.5	+39.5
Noise Figure at min. attenuation	dB	4.3	4.5	
Gain Variation Range	dB	26.6	26.6	33.6
Supply Voltage	V	+5		
Amplifier Current, Pin25	mA	150		

Absolute Maximum Rating

Parameter	Rating
Storage Temperature	-55 to +125 °C
Amplifier Supply Voltage (pin 25)	+6 V
Pin 5 (Gain Control) Current	30 mA
RF Input Power (continuous)	+12 dBm
Junction Temperature, T _j	+160° C
Thermal Resistance, R _{th}	59 °C / W

Operation of this device above any of these parameters may cause permanent damage.

Ordering Information

Part No.	Description
VG111-F	1.7-2.7GHz Variable Gain Amplifier (lead-free/RoHS-compliant QFN package)
VG111-PCB1900	1.8 – 2.0 GHz Fully Assembled Application Board
VG111-PCB2100	2.0 – 2.2 GHz Fully Assembled Application Board

Standard T/R size = 500 pieces on a 7" reel.

Specifications and information are subject to change without notice



VG111

1.7 – 2.7 GHz Variable Gain Amplifier



Application Circuit: 1.8 – 2.0 GHz (VG111-PCB1900)

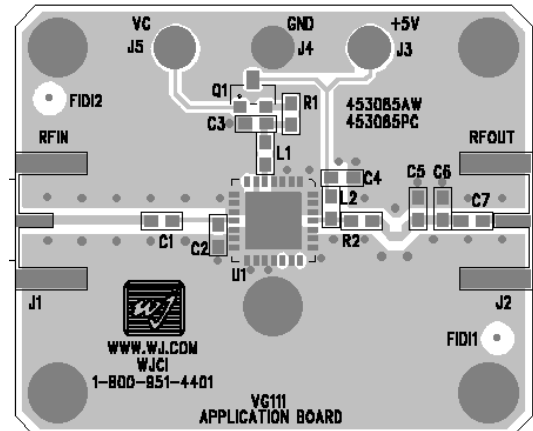
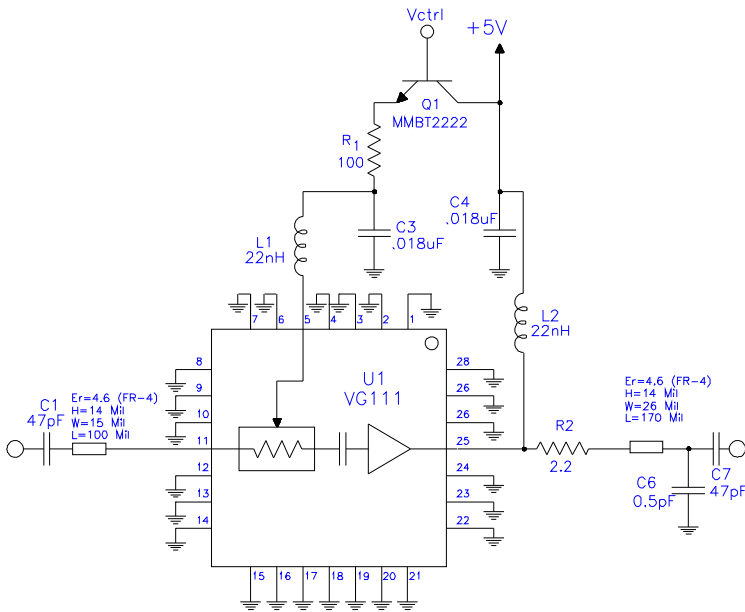

Circuit Board Material: .014" FR-4, 4 layers, .062" total thickness

Bill of Materials

Ref. Des.	Description	Size
C1, C7	47 pF Chip Capacitor	0603
C2, C5	Do Not Place	
C3, C4	0.01 μ F Chip Capacitor	0603
C6	0.5 pF Chip Capacitor	0603
L1, L2	22 nH Chip Inductor	0603
R1	100 Ω Chip Resistor	0603
R2	2.2 Ω Chip Resistor	0603
Q1	MMBT2222 Motorola Transistor	SOT-23
U1	VG111 Variable Gain Amplifier	QFN 6x6

- The amplifier is biased through Pin 25 and should be connected directly into a voltage regulator.
- Components shown in the silkscreen but not on the schematic are not used for this circuit.
- Distances are shown from the edge-to-edge for the land pattern.

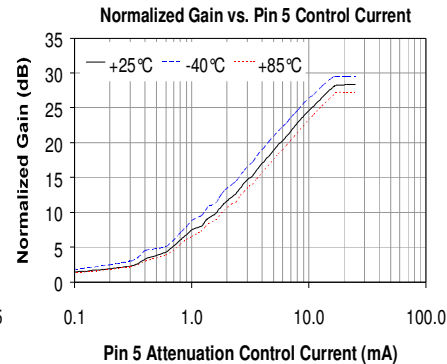
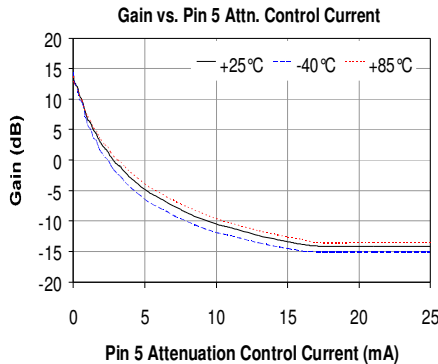
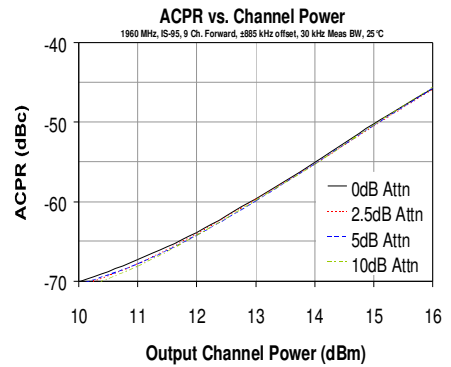
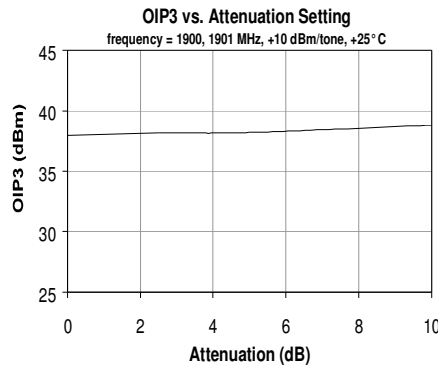
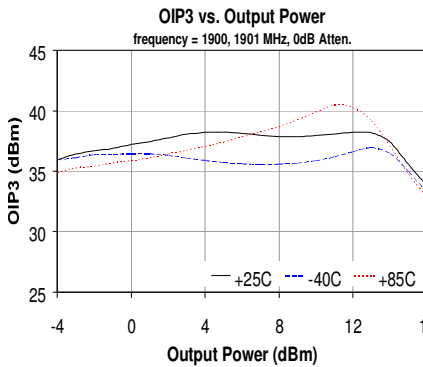

Specifications and information are subject to change without notice



VG111

1.7 – 2.7 GHz Variable Gain Amplifier



VG111-PCB1900 Application Circuit Performance (cont'd)

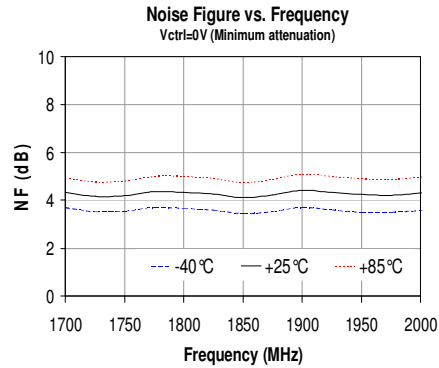
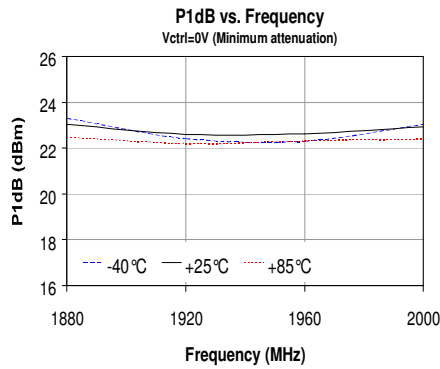
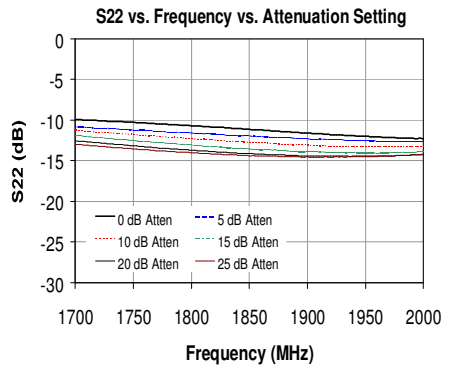
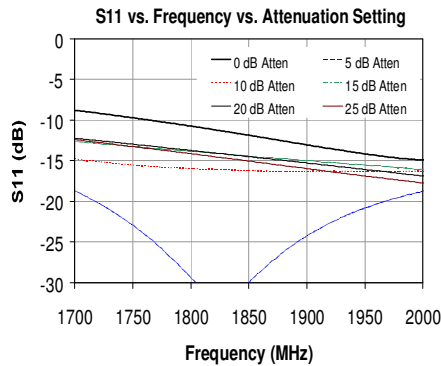
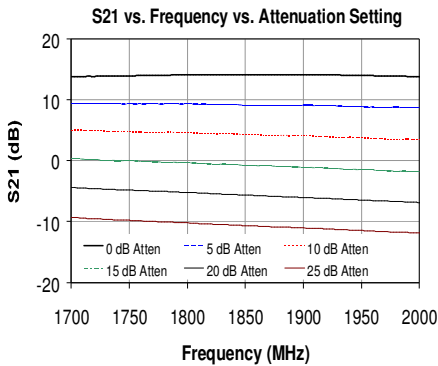
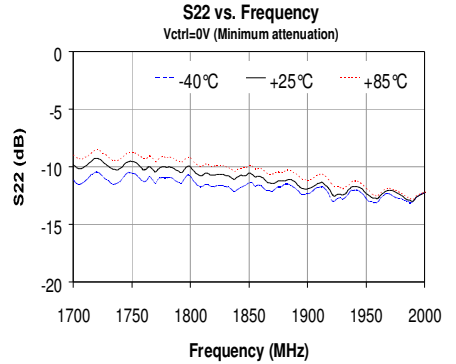
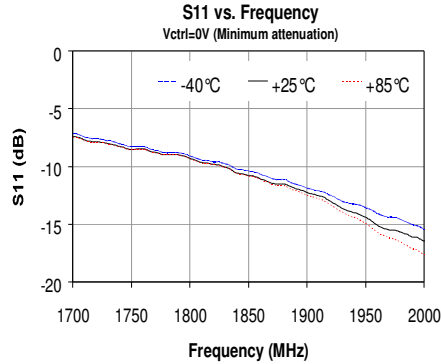
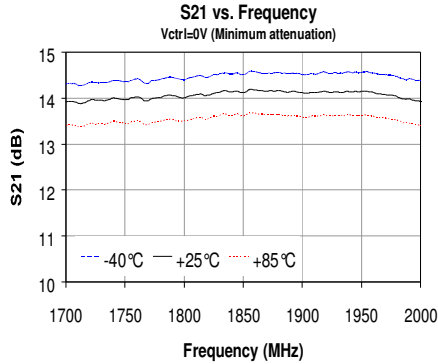



VG111

1.7 – 2.7 GHz Variable Gain Amplifier



Application Circuit: 2.0 – 2.2 GHz (VG111-PCB2100)

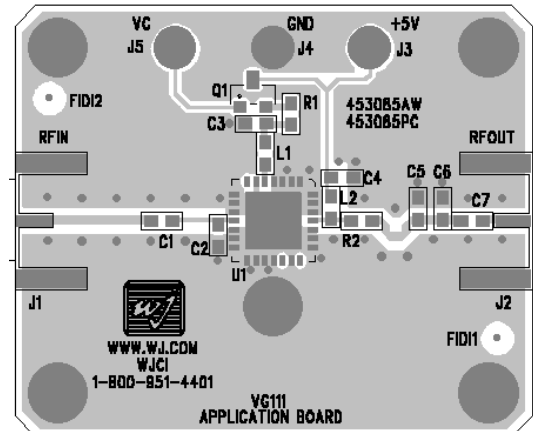
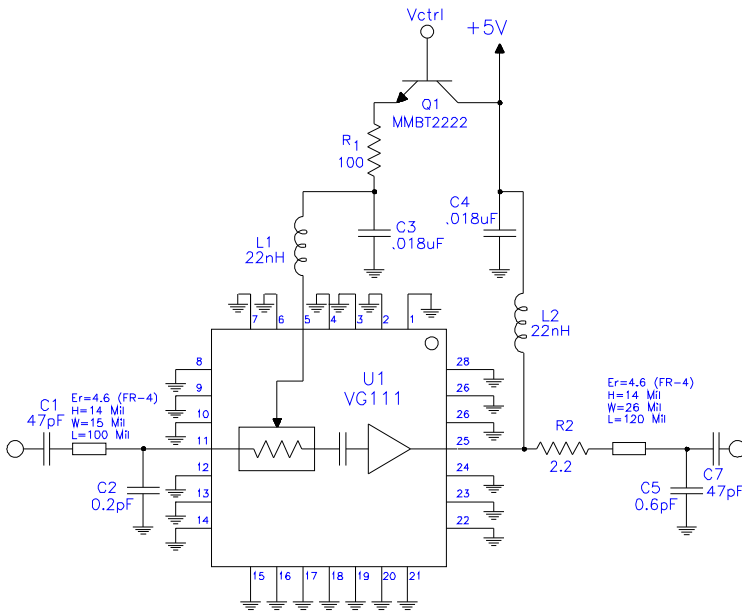

Circuit Board Material: .014" FR-4, 4 layers, .062" total thickness

Bill of Materials

Ref. Des.	Description	Size
C1, C7	47 pF Chip Capacitor	0603
C2	0.2 pF Chip Capacitor	0603
C3, C4	0.01 μF Chip Capacitor	0603
C5	0.6 pF Chip Capacitor	0603
C6	Do Not Place	
L1, L2	22 nH Chip Inductor	0603
R1	100 Ω Chip Resistor	0603
R2	2.2 Ω Chip Resistor	0603
Q1	MMBT2222 Motorola Transistor	SOT-23
U1	VG111 Variable Gain Amplifier	QFN 6x6

- The amplifier is biased through Pin 25 and should be connected directly into a voltage regulator.
- Components shown in the silkscreen but not on the schematic are not used for this circuit.
- Distances are shown from the edge-to-edge for the land pattern.

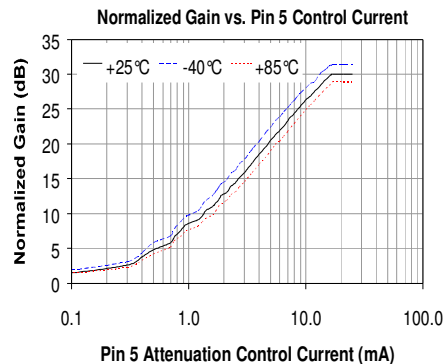
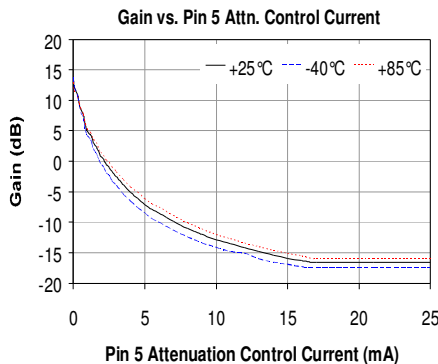
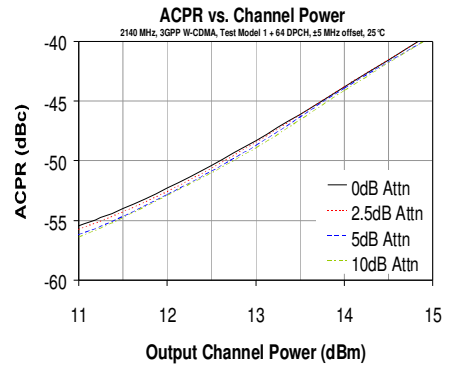
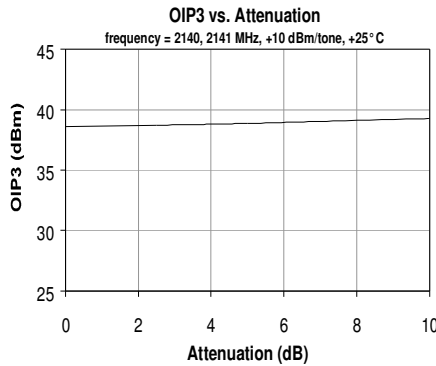
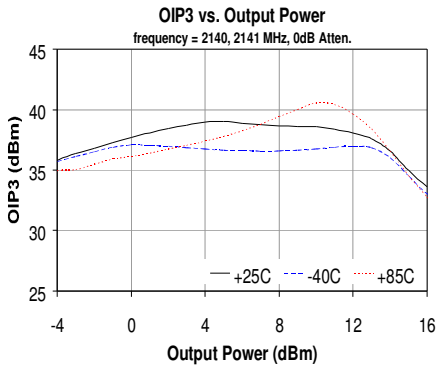

Specifications and information are subject to change without notice



VG111

1.7 – 2.7 GHz Variable Gain Amplifier



VG111-PCB2100 Application Circuit Performance (cont'd)

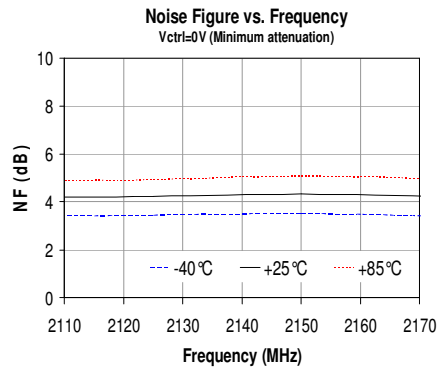
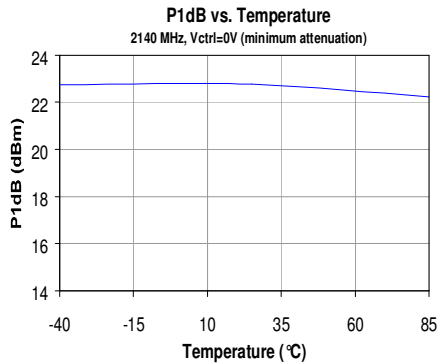
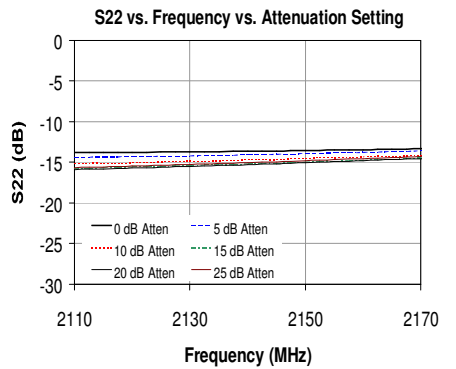
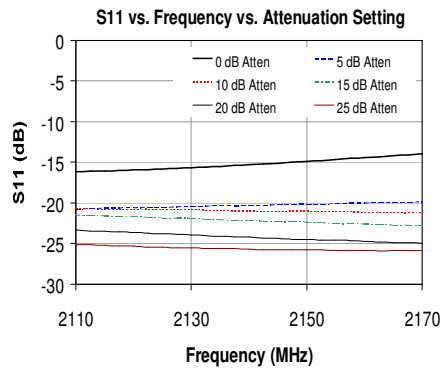
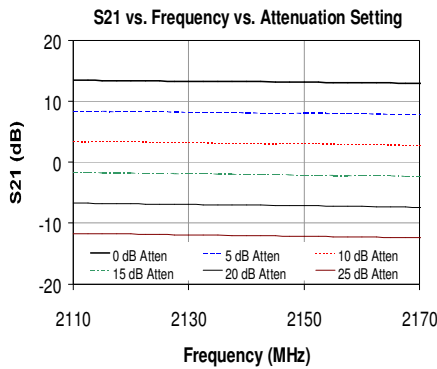
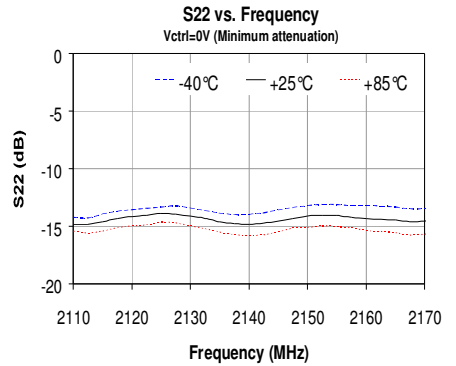
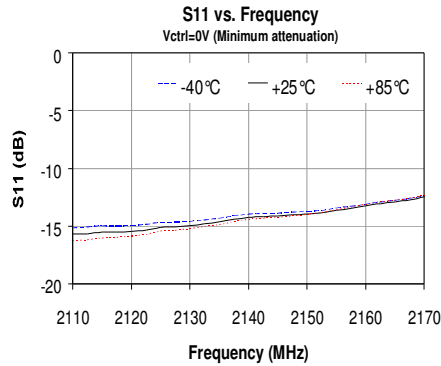
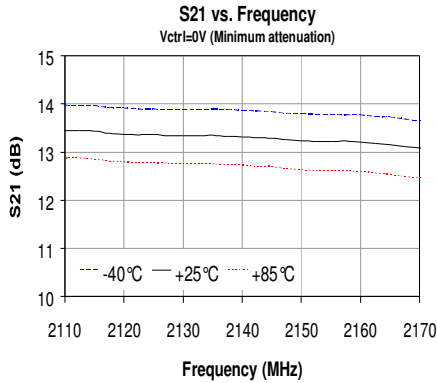



VG111

1.7 – 2.7 GHz Variable Gain Amplifier



Application Circuit: 2.4 – 2.7 GHz Reference Design

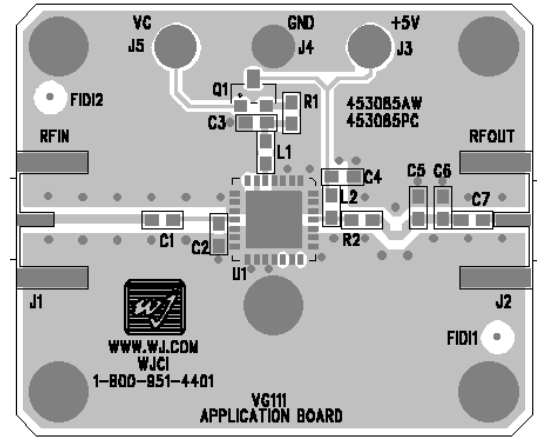
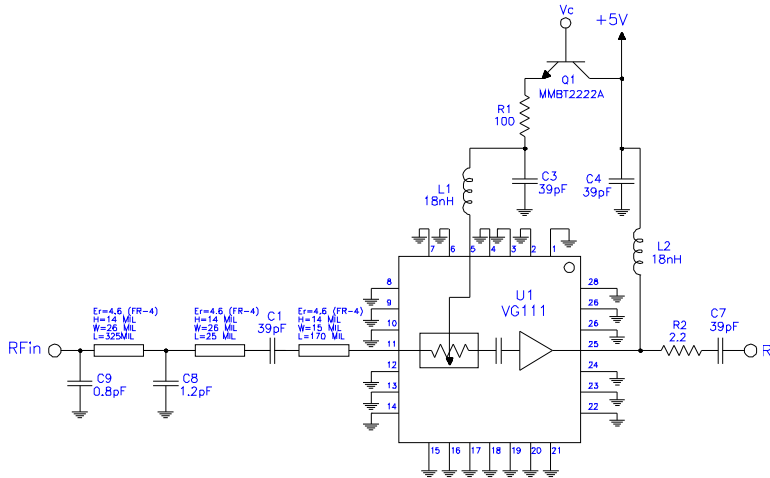

Circuit Board Material: .014" FR-4, 4 layers, .062" total thickness

- The amplifier is biased through Pin 25 and should be connected directly into a voltage regulator.
- Components shown in the silkscreen but not on the schematic are not used for this circuit.
- Distances are shown from the edge-to-edge for the land pattern.

Bill of Materials

Ref. Des.	Description	Size
C1, C7	39 pF Chip Capacitor	0603
C8	1.2 pF Chip Capacitor	0603
C3, C4	39 pF Chip Capacitor	0603
C9	0.8 pF Chip Capacitor	0603
C5, C6	Do Not Place	
L1, L2	18 nH Chip Inductor	0603
R1	100 Ω Chip Resistor	0603
R2	2.2 Ω Chip Resistor	0603
Q1	Transistor	SOT-23
U1	VG111 Variable Gain Amplifier	QFN 6x6

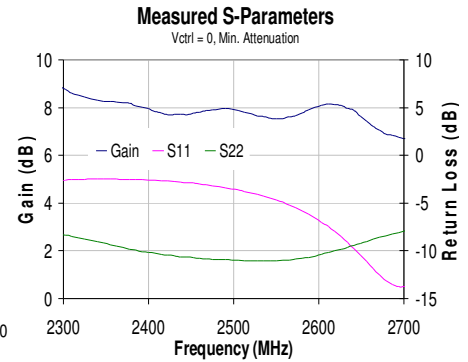
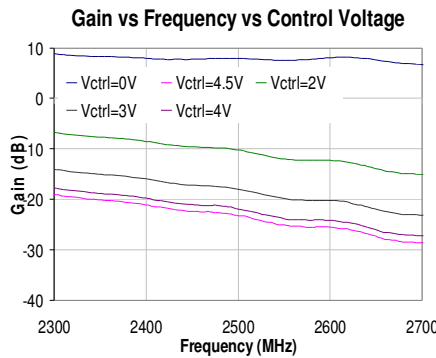
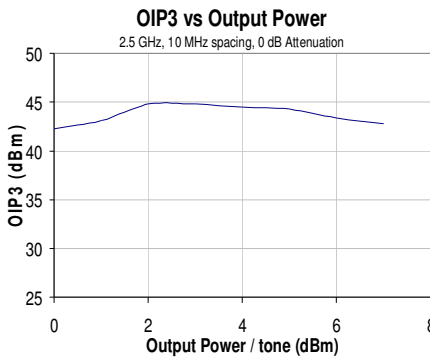

Specifications and information are subject to change without notice

Mechanical Information

This package is lead-free/RoHS-compliant. The plating material on the pins is annealed matte tin over copper. It is compatible with both lead-free (maximum 260 °C reflow temperature) and leaded (maximum 245 °C reflow temperature) soldering processes.

Outline Drawing

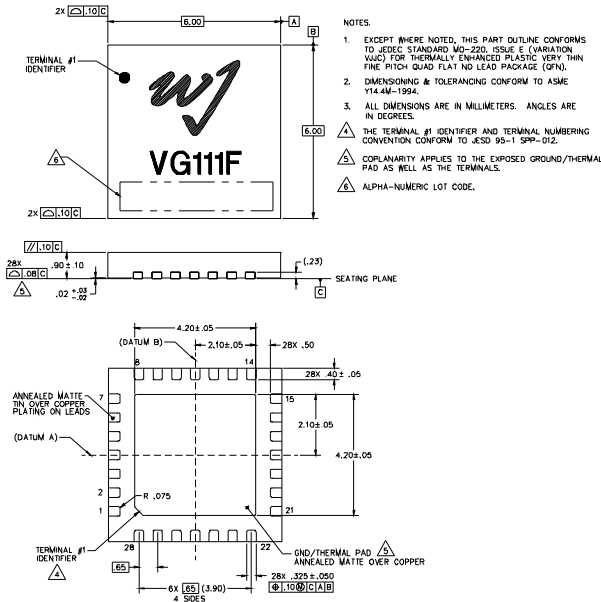

Product Marking

The component will be lasermarked with a “VG111F” designator with an alphanumeric lot code on the top surface of the package.

Tape and reel specifications for this part will be located on the website in the “Application Notes” section.

ESD / MSL Information



Caution! ESD sensitive device.

ESD Rating: Class 1B
 Value: Passes $\geq 500V$ to $<1000V$
 Test: Human Body Model (HBM)
 Standard: JEDEC Standard JESD22-A114

ESD Rating: Class IV
 Value: Passes $\geq 1000V$ to $<2000V$
 Test: Charged Device Model (CDM)
 Standard: JEDEC Standard JESD22-C101

MSL Rating: Level 2 at $+260^{\circ}C$ convection reflow
 Standard: JEDEC Standard J-STD-020

Mounting Configuration / Land Pattern

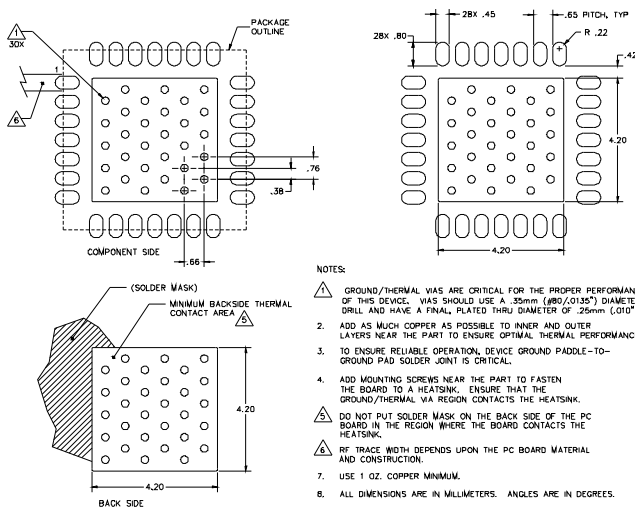

Functional Pin Layout

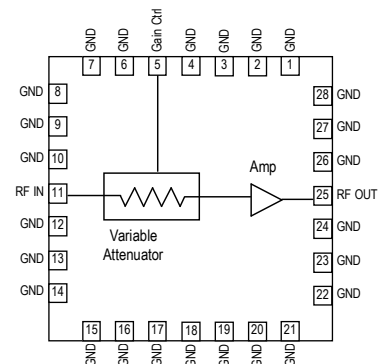

Function	Pin No
Gain Control	5
RF Input	11
RF Output / DC bias	25
No Connect or GND	All other pins
Ground	Backside copper

The even numbered pins are hard grounded to the backside paddle internally.

X-ON Electronics

Largest Supplier of Electrical and Electronic Components

Click to view similar products for [RF Amplifier](#) category:

Click to view products by [TriQuint Semiconductor](#) manufacturer:

Other Similar products are found below :

[ADPA7006AEHZ](#) [CXE2089ZSR](#) [MGA-43828-BLKG](#) [A82-1](#) [RF2878TR7](#) [BGA 728L7 E6327](#) [BGB719N7ESDE6327XTMA1](#) [HMC1126-SX](#) [HMC342](#) [HMC561-SX](#) [HMC598-SX](#) [HMC-ALH382-SX](#) [HMC-ALH476-SX](#) [SE2433T-R](#) [SE2622L-R](#) [SMA3101-TL-E](#) [SMA39](#) [SMA70-1](#) [A66-1](#) [A66-3](#) [A67-1](#) [LX5535LQ](#) [LX5540LL](#) [RF2373TR7](#) [HMC3653LP3BETR](#) [HMC395](#) [HMC549MS8GETR](#) [HMC576-SX](#) [HMC754S8GETR](#) [HMC-ALH435-SX](#) [SMA101](#) [SMA1031](#) [SMA181](#) [SMA32](#) [SMA411](#) [SMA531](#) [SST12LP17E-XX8E](#) [SST12LP19E-QX6E](#) [TGA2598](#) [WPM0510A](#) [HMC5929LS6TR](#) [HMC5879LS7TR](#) [HMC906A-SX](#) [HMC1127](#) [HMC544A](#) [HMC1126](#) [HMC1110-SX](#) [HMC1087F10](#) [HMC1086](#) [HMC1016](#)