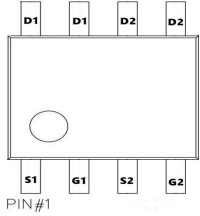
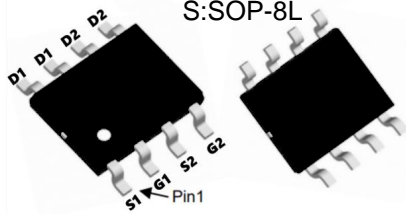
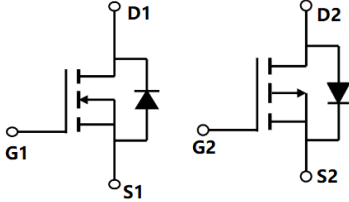

**TM021G02S**

**N+P-Channel Enhancement Mode Mosfet**

<p><b>General Description</b></p> <ul style="list-style-type: none"> <li>• Low <math>R_{DS(ON)}</math></li> <li>• RoHS and Halogen-Free Compliant</li> </ul> <p><b>Applications</b></p> <ul style="list-style-type: none"> <li>• Load switch</li> <li>• PWM</li> </ul>	<p><b>Product Summary</b></p> <p><b>N Channel</b>  <math>V_{DS} = 20V, I_D = 6.0A</math>  <math>R_{DS(ON)} = 21m\Omega (typ.) @ V_{GS} = 4.5V</math></p> <p><b>P Channel</b>  <math>V_{DS} = -20V, I_D = -5.0A</math>  <math>R_{DS(ON)} = 52m\Omega (typ.) @ V_{GS} = 4.5V</math></p> <p>100% UIS Tested                  100% <math>R_g</math> Tested</p> 
--	--

Marking: 06G02 OR 4606B

**Absolute Maximum Ratings ( $T_C = 25^\circ C$  unless otherwise noted)**

Symbol	Parameter	Rating		Units
		N-Channel	P-Channel	
$V_{DS}$	Drain-Source Voltage	20	-20	V
$V_{GS}$	Gate-Source Voltage	$\pm 12$	$\pm 12$	V
$I_D @ T_C = 25^\circ C$	Continuous Drain Current, $V_{GS} @ 10V^1$	6	-5	A
$I_D @ T_C = 100^\circ C$	Continuous Drain Current, $V_{GS} @ 10V^1$	5	-4	A
$I_{DM}$	Pulsed Drain Current <sup>2</sup>	20	-12	A
EAS	Single Pulse Avalanche Energy <sup>3</sup>	72	59	mJ
$I_{AS}$	Avalanche Current	21	-19	A
$P_D @ T_C = 25^\circ C$	Total Power Dissipation <sup>4</sup>	2.5	2.08	W
$T_{STG}$	Storage Temperature Range	-55 to 150	-55 to 150	$^\circ C$
$T_J$	Operating Junction Temperature Range	-55 to 150	-55 to 150	$^\circ C$

**Thermal Data**

Symbol	Parameter	Typ.	Max.	Unit
$R_{\theta JA}$	Thermal Resistance Junction-Ambient <sup>1</sup>	---	85	$^\circ C/W$
$R_{\theta JC}$	Thermal Resistance Junction-Case <sup>1</sup>	---	50	$^\circ C/W$

**TM021G02S**

**N+P-Channel Enhancement Mode Mosfet**

**N-Channel Electrical Characteristics (T<sub>J</sub>=25 °C, unless otherwise noted)**

Symbol	Parameter	Test Condition	Min.	Typ.	Max.	Units
<b>Off Characteristic</b>						
V <sub>(BR)DSS</sub>	Drain-Source Breakdown Voltage	V <sub>GS</sub> =0V, I <sub>D</sub> =250μA	20	-	-	V
I <sub>DSS</sub>	Zero Gate Voltage Drain Current	V <sub>DS</sub> =20V, V <sub>GS</sub> =0V,	-	-	1.0	μA
I <sub>GSS</sub>	Gate to Body Leakage Current	V <sub>DS</sub> =0V, V <sub>GS</sub> =±12V	-	-	±100	nA
<b>On Characteristics</b>						
V <sub>GS(th)</sub>	Gate Threshold Voltage	V <sub>DS</sub> =V <sub>GS</sub> , I <sub>D</sub> =250μA	0.4	0.7	1	V
R <sub>DS(on)</sub>	Static Drain-Source on-Resistance note2	V <sub>GS</sub> =4.5V, I <sub>D</sub> =4A	-	21	27	mΩ
		V <sub>GS</sub> =2.5V, I <sub>D</sub> =3A	-	29	44	
<b>Dynamic Characteristics</b>						
C <sub>iss</sub>	Input Capacitance	V <sub>DS</sub> =10V, V <sub>GS</sub> =0V, f=1.0MHz	-	358	-	pF
C <sub>oss</sub>	Output Capacitance		-	69.3	-	pF
C <sub>rss</sub>	Reverse Transfer Capacitance		-	58.5	-	pF
Q <sub>g</sub>	Total Gate Charge	V <sub>DS</sub> =10V, I <sub>D</sub> =2A, V <sub>GS</sub> =4.5V	-	5.6	-	nC
Q <sub>gs</sub>	Gate-Source Charge		-	0.8	-	nC
Q <sub>gd</sub>	Gate-Drain("Miller") Charge		-	1	-	nC
<b>Switching Characteristics</b>						
t <sub>d(on)</sub>	Turn-on Delay Time	V <sub>DS</sub> =10V, I <sub>D</sub> =4A, R <sub>GEN</sub> =3Ω, V <sub>GS</sub> =4.5V	-	5	-	ns
t <sub>r</sub>	Turn-on Rise Time		-	30	-	ns
t <sub>d(off)</sub>	Turn-off Delay Time		-	48	-	ns
t <sub>f</sub>	Turn-off Fall Time		-	36	-	ns
<b>Drain-Source Diode Characteristics and Maximum Ratings</b>						
I <sub>S</sub>	Maximum Continuous Drain to Source Diode Forward Current		-	-	6	A
I <sub>SM</sub>	Maximum Pulsed Drain to Source Diode Forward Current		-	-	16	A
V <sub>SD</sub>	Drain to Source Diode Forward Voltage	V <sub>GS</sub> =0V, I <sub>S</sub> =4A	-	-	1.2	V

Notes:1. Repetitive Rating: Pulse Width Limited by Maximum Junction Temperature

2. Pulse Test: Pulse Width≤300μs, Duty Cycle≤0.5%

**TM021G02S**

**N+P-Channel Enhancement Mode Mosfet**

**P-Channel Electrical Characteristics (T<sub>J</sub>=25 °C, unless otherwise noted)**

Symbol	Parameter	Test Condition	Min.	Typ.	Max.	Units
<b>Off Characteristic</b>						
V <sub>(BR)DSS</sub>	Drain-Source Breakdown Voltage	V <sub>GS</sub> =0V, I <sub>D</sub> = -250μA	-20	-	-	V
I <sub>DSS</sub>	Zero Gate Voltage Drain Current	V <sub>DS</sub> = -20V, V <sub>GS</sub> =0V,	-	-	-1	μA
I <sub>GSS</sub>	Gate to Body Leakage Current	V <sub>DS</sub> =0V, V <sub>GS</sub> = ±12V	-	-	±100	nA
<b>On Characteristics</b>						
V <sub>GS(th)</sub>	Gate Threshold Voltage	V <sub>DS</sub> =V <sub>GS</sub> , I <sub>D</sub> = -250μA	-0.5	-0.7	-1.0	V
R <sub>DS(on)</sub>	Static Drain-Source on-Resistance <small>note2</small>	V <sub>GS</sub> = -4.5V, I <sub>D</sub> = -3A	-	52	70	mΩ
		V <sub>GS</sub> = -2.5V, I <sub>D</sub> = -2A	-	70	100	
<b>Dynamic Characteristics</b>						
C <sub>iss</sub>	Input Capacitance	V <sub>DS</sub> = -10V, V <sub>GS</sub> =0V, f=1.0MHz	-	503	-	pF
C <sub>oss</sub>	Output Capacitance		-	67	-	pF
C <sub>rss</sub>	Reverse Transfer Capacitance		-	58	-	pF
Q <sub>g</sub>	Total Gate Charge	V <sub>DS</sub> = -10V, I <sub>D</sub> = -2A, V <sub>GS</sub> = -4.5V	-	4.1	-	nC
Q <sub>gs</sub>	Gate-Source Charge		-	0.8	-	nC
Q <sub>gd</sub>	Gate-Drain("Miller") Charge		-	1.1	-	nC
<b>Switching Characteristics</b>						
t <sub>d(on)</sub>	Turn-on Delay Time	V <sub>DD</sub> = -10V, I <sub>D</sub> = -3A, R <sub>G</sub> =1Ω, V <sub>GEN</sub> = -4.5V, R <sub>L</sub> =1.2Ω	-	11	-	ns
t <sub>r</sub>	Turn-on Rise Time		-	52	-	ns
t <sub>d(off)</sub>	Turn-off Delay Time		-	16	-	ns
t <sub>f</sub>	Turn-off Fall Time		-	10	-	ns
<b>Drain-Source Diode Characteristics and Maximum Ratings</b>						
I <sub>S</sub>	Maximum Continuous Drain to Source Diode Forward Current		-	-	-5	A
I <sub>SM</sub>	Maximum Pulsed Drain to Source Diode Forward Current		-	-	-12	A
V <sub>SD</sub>	Drain to Source Diode Forward Voltage	V <sub>GS</sub> =0V, I <sub>S</sub> = -3A	-	-	-1.2	V

Notes:1. Repetitive Rating: Pulse Width Limited by Maximum Junction Temperature  
 2. Pulse Test: Pulse Width≤300μs, Duty Cycle≤2%

## Typical Performance Characteristics

### N-Channel Typical Characteristics

Figure 1: Output Characteristics

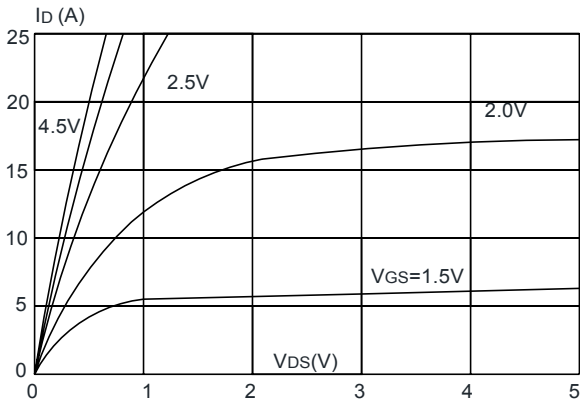

Figure 2: Typical Transfer Characteristics

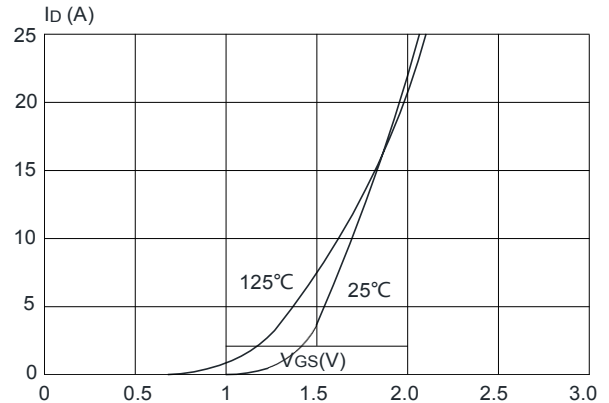

Figure 3: On-resistance vs. Drain Current

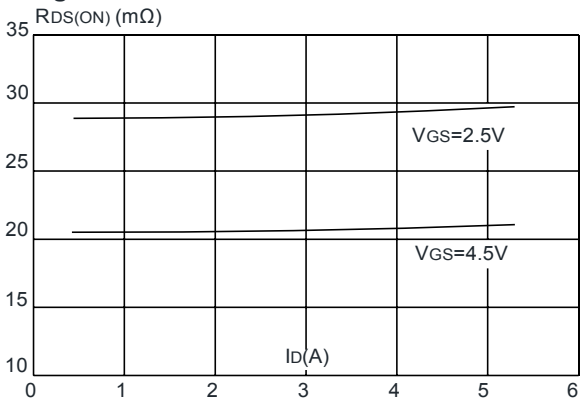

Figure 4: Body Diode Characteristics

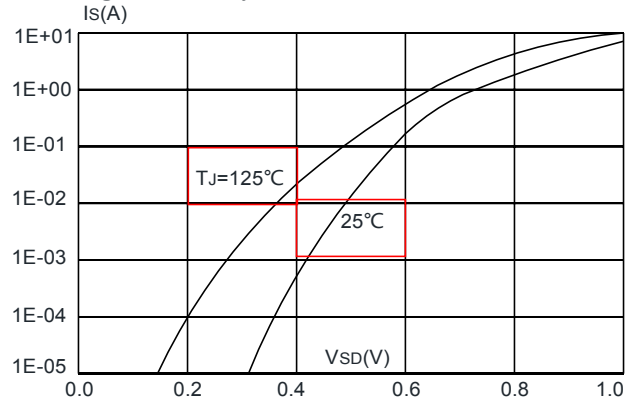

Figure 5: Gate Charge Characteristics

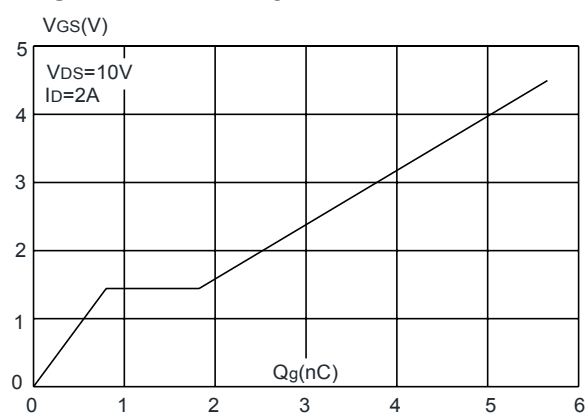
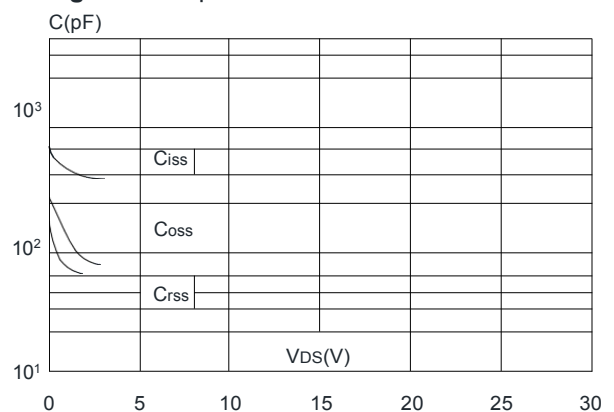

Figure 6: Capacitance Characteristics



TM021G02S

N+P-Channel Enhancement Mode Mosfet

Typical Performance Characteristics

P-Channel Typical Characteristics

Figure 1: Output Characteristics

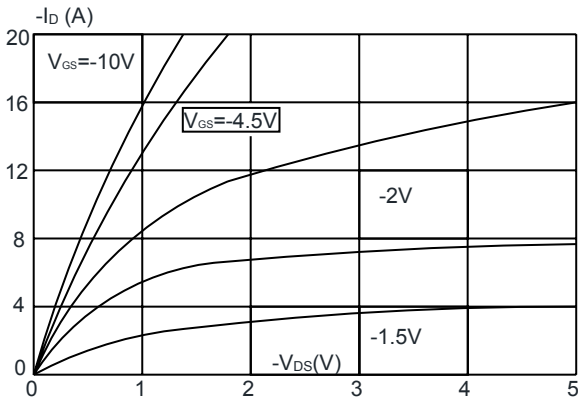

Figure 2: Typical Transfer Characteristics

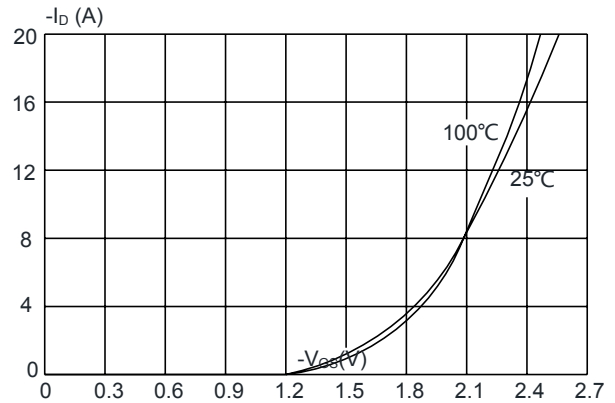

Figure 3: On-resistance vs. Drain Current

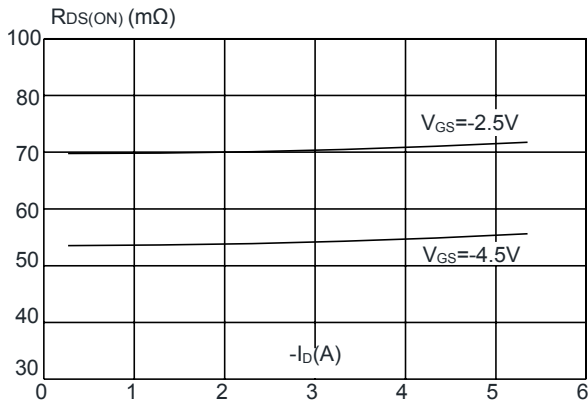

Figure 4: Body Diode Characteristics

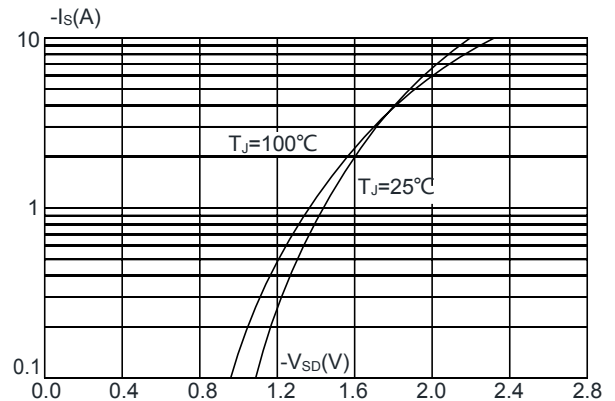

Figure 5: Gate Charge Characteristics

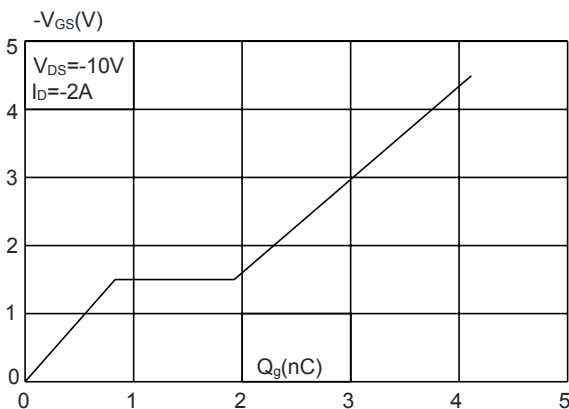
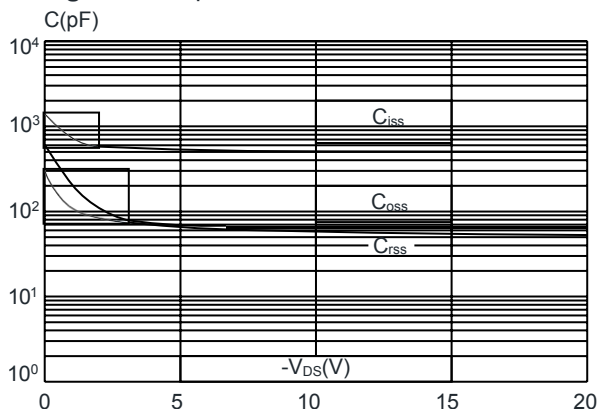
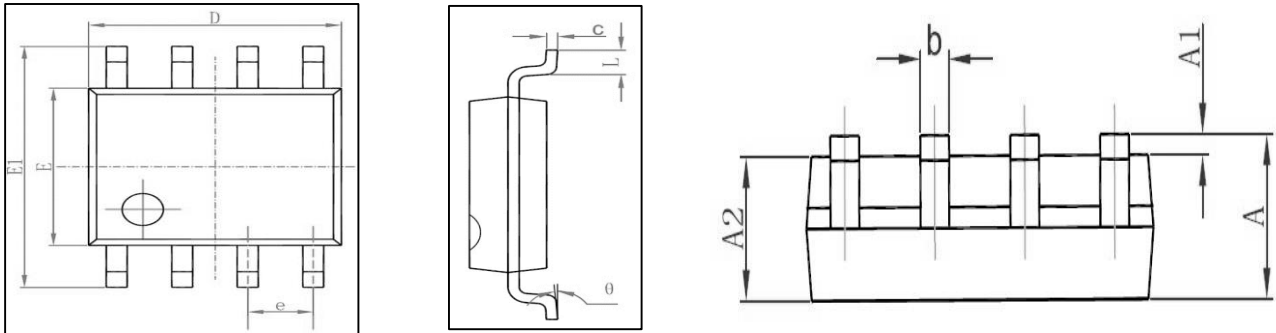

Figure 6: Capacitance Characteristics



## Package Mechanical Data:SOP-8L



Symbol	Dimensions In Millimeters		Dimensions In Inches	
	Min	Max	Min	Max
A	1.350	1.750	0.053	0.069
A1	0.100	0.250	0.004	0.010
A2	1.350	1.550	0.053	0.061
b	0.330	0.510	0.013	0.020
c	0.170	0.250	0.006	0.010
D	4.700	5.100	0.185	0.200
E	3.800	4.000	0.150	0.157
E1	5.800	6.200	0.228	0.244
e	1.270 (BSC)		0.050 (BSC)	
L	0.400	1.270	0.016	0.050
$\theta$	0°	8°	0°	8°

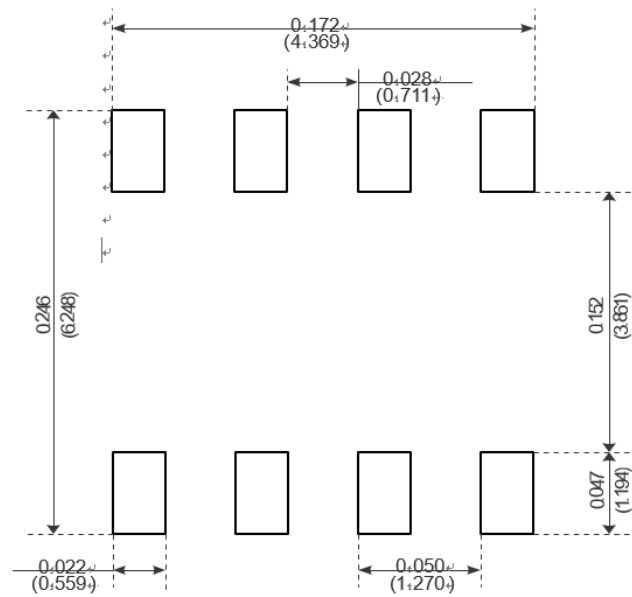

Recommended Minimum Pads

## X-ON Electronics

Largest Supplier of Electrical and Electronic Components

*Click to view similar products for [MOSFET](#) category:*

*Click to view products by [Tritech-MOS](#) manufacturer:*

Other Similar products are found below :

[IRFD120](#) [JANTX2N5237](#) [BUK455-60A/B](#) [MIC4420CM-TR](#) [VN1206L](#) [NDP4060](#) [SI4482DY](#) [IPS70R2K0CEAKMA1](#) [SQD23N06-31L-GE3](#)  
[TK16J60W,S1VQ\(O](#) [2SK2614\(TE16L1,Q\)](#) [DMN1017UCP3-7](#) [DMN1053UCP4-7](#) [SQJ469EP-T1-GE3](#) [NTE2384](#) [DMC2700UDMQ-7](#)  
[DMN2080UCB4-7](#) [DMN61D9UWQ-13](#) [US6M2GTR](#) [DMN31D5UDJ-7](#) [DMP22D4UFO-7B](#) [DMN1006UCA6-7](#) [DMN16M9UCA6-7](#)  
[STF5N65M6](#) [IRF40H233XTMA1](#) [STU5N65M6](#) [DMN6022SSD-13](#) [DMN13M9UCA6-7](#) [DMTH10H4M6SPS-13](#) [DMN2990UFB-7B](#)  
[IPB80P04P405ATMA2](#) [2N7002W-G](#) [MCAC30N06Y-TP](#) [MCQ7328-TP](#) [BXP7N65D](#) [BXP4N65F](#) [AOL1454G](#) [WMJ80N60C4](#) [BXP2N20L](#)  
[BXP2N65D](#) [BXT1150N10J](#) [BXT1700P06M](#) [TSM60NB380CP](#) [ROG](#) [RQ7L055BGTCR](#) [DMNH15H110SK3-13](#) [SLF10N65ABV2](#)  
[BSO203SP](#) [BSO211P](#) [IPA60R230P6](#) [IPA60R460CE](#)