

SWITCHING REGULATOR APPLICATIONS

Features

- High Voltage : $BV_{DSS}=300V(\text{Min.})$
- Low C_{rss} : $C_{rss}=19pF(\text{Typ.})$
- Low gate charge : $Qg=24nC(\text{Typ.})$
- Low $R_{DS(on)}$: $R_{DS(on)}=0.29\Omega(\text{Max.})$

Ordering Information

Type No.	Marking	Package Code
TSF14N30M	TSF14N30M	TO-220F-3L

PIN Connection

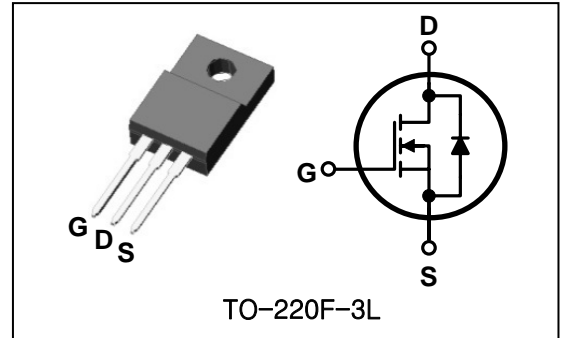

Absolute maximum ratings ($T_C=25^\circ\text{C}$ unless otherwise noted)

Characteristic	Symbol	Rating	Unit	
Drain-source voltage	V_{DSS}	300	V	
Gate-source voltage	V_{GSS}	± 30	V	
Drain current (DC) *	I_D	$T_C=25^\circ\text{C}$	14	A
		$T_C=100^\circ\text{C}$	8.8	A
Drain current (Pulsed) *	I_{DM}	56	A	
Power dissipation	P_D	35	W	
Avalanche current (Single) ②	I_{AS}	14	A	
Single pulsed avalanche energy ②	E_{AS}	800	mJ	
Avalanche current (Repetitive) ①	I_{AR}	14	A	
Repetitive avalanche energy ①	E_{AR}	25	mJ	
Junction temperature	T_J	150	°C	
Storage temperature range	T_{stg}	-55~150		

* Limited by maximum junction temperature

Characteristic	Symbol	Typ.	Max.	Unit
Thermal resistance	Junction-case	-	0.89	°C/W
	Junction-ambient	-	62.5	

Electrical Characteristics (T_C=25°C unless otherwise noted)

Characteristic	Symbol	Test Condition	Min.	Typ.	Max.	Unit	
Drain-source breakdown voltage	BV _{DSS}	I _D =250μA, V _{GS} =0V	300	-	-	V	
Gate threshold voltage	V _{GS(th)}	I _D =250μA, V _{DS} =V _{GS}	3.0	-	5.0	V	
Drain-source cut-off current	I _{DSS}	V _{DS} =300V, V _{GS} =0V	-	-	1	μA	
		V _{DS} =300V, V _{GS} =0V, TC=125°C	-	-	200		
Gate leakage current	I _{GSS}	V _{DS} =0V, V _{GS} =±30V	-	-	±100	nA	
Drain-source on-resistance ④	R _{DS(on)}	V _{GS} =10V, I _D =7.0A	-	0.24	0.29	Ω	
Forward transfer conductance ④	g _{fs}	V _{DS} =10V, I _D =7.0A	-	7.8	-	S	
Input capacitance	C _{iss}	V _{GS} =0V, V _{DS} =25V f=1 MHz	-	1075	1344	pF	
Output capacitance	C _{oss}		-	182	228		
Reverse transfer capacitance	C _{rss}		-	19	23.8		
Turn-on delay time	t _{d(on)}	V _{DD} =150V, I _D =14A R _G =25Ω	-	22	-	ns	
Rise time	t _r		-	145	-		
Turn-off delay time	t _{d(off)}		③④	-	45		-
Fall time	t _f		-	70	-		
Total gate charge	Q _g	V _{DS} =240V, V _{GS} =10V I _D =14A	-	24	30	nC	
Gate-source charge	Q _{gs}		③④	-	8.5		-
Gate-drain charge	Q _{gd}		-	-	9.5		-

Source-Drain Diode Ratings and Characteristics (T_C=25°C unless otherwise noted)

Characteristic	Symbol	Test Condition	Min.	Typ.	Max.	Unit
Source current (DC)	I _S	Integral reverse diode in the MOSFET	-	-	14	A
Source current (Pulsed) ①	I _{SM}		-	-	56	
Forward voltage ④	V _{SD}	V _{GS} =0V, I _S =14A	-	-	1.4	V
Reverse recovery time	t _{rr}	I _S =14A, V _{GS} =0V dI _F /dt=100A/us	-	235	-	ns
Reverse recovery charge	Q _{rr}		-	1.6	-	μC

Note ;

- ① Repetitive rating : Pulse width limited by maximum junction temperature
- ② L=6.8mH, I_{AS}=14A, V_{DD}=50V, R_G=25Ω, Starting T_J=25°C
- ③ Pulse Test : Pulse width≤300us, Duty cycle≤2%
- ④ Essentially independent of operating temperature

Electrical Characteristic Curves

Fig. 1 $I_D - V_{DS}$

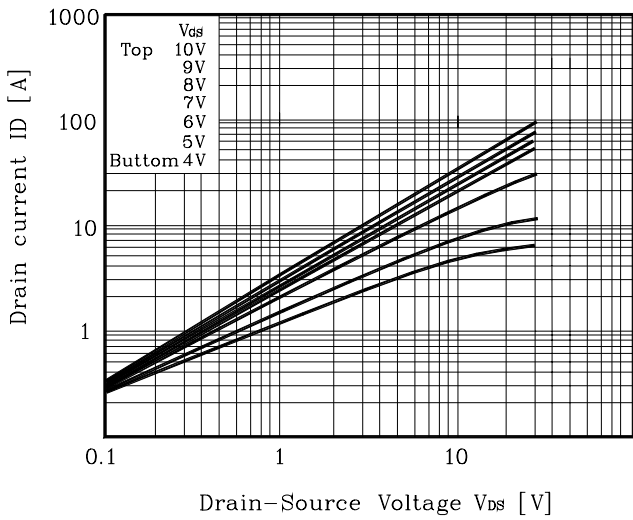

Fig. 2 $I_D - V_{GS}$

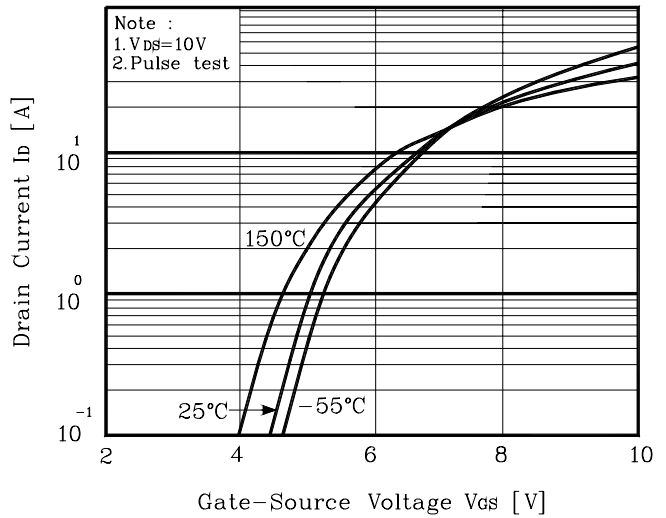

Fig. 3 $R_{DS(on)} - I_D$

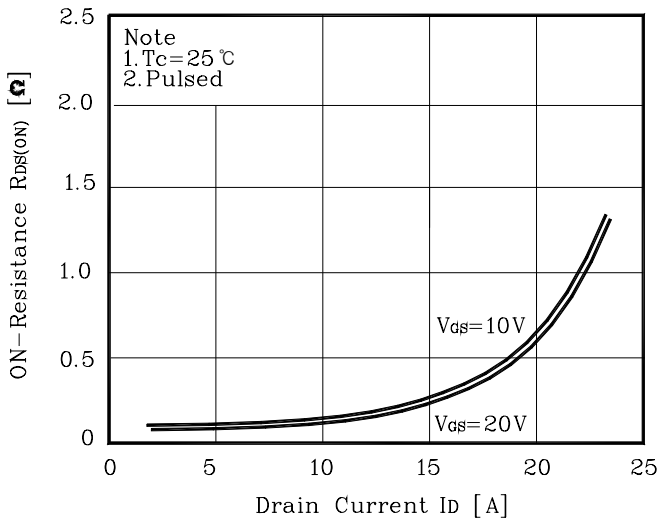

Fig. 4 $I_S - V_{SD}$

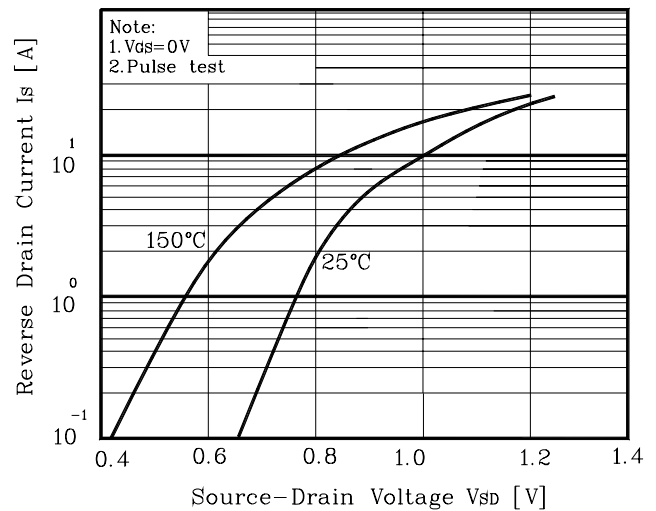

Fig. 5 Capacitance - V_{DS}

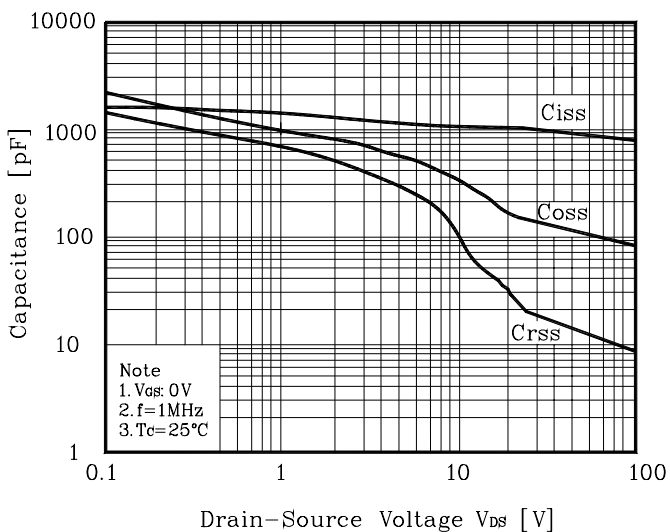

Fig. 6 $V_{GS} - Q_G$

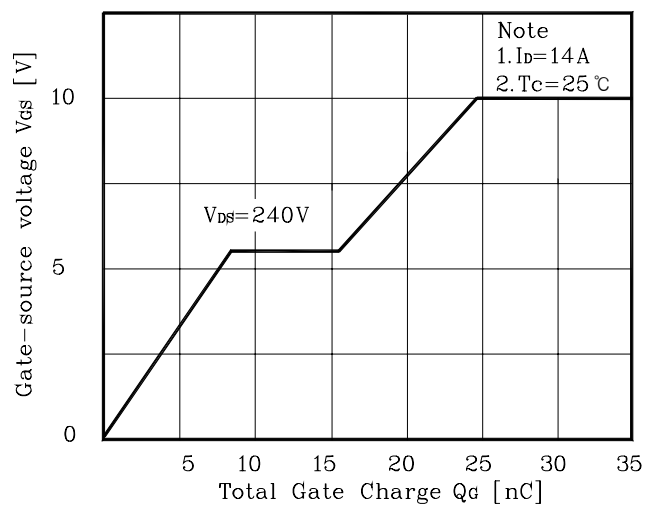

Fig. 7 $V_{DSS} - T_J$

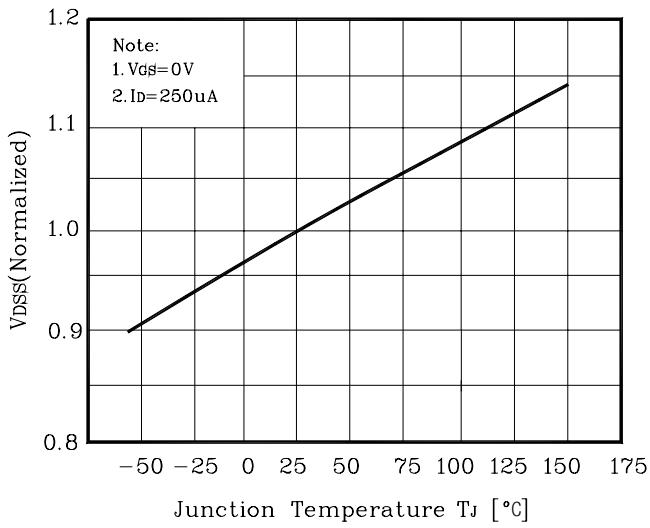

Fig. 8 $R_{DS(on)} - T_J$

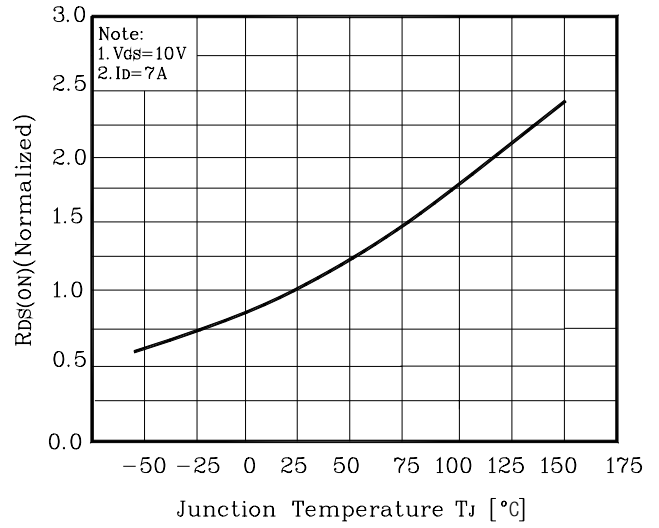

Fig. 9 $I_D - T_C$

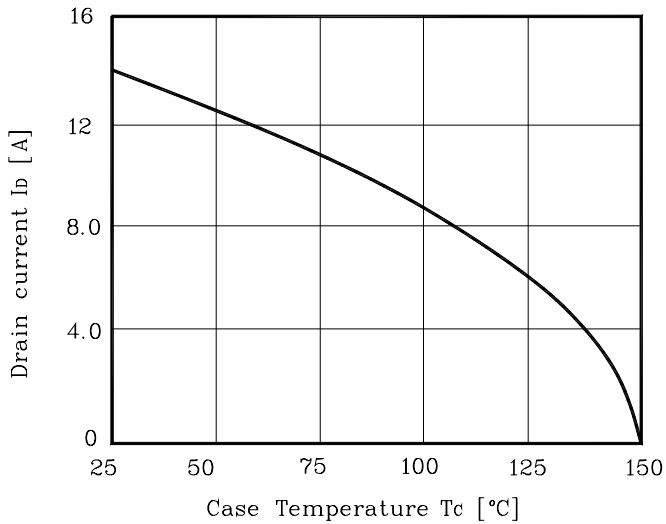

Fig. 10 Safe Operating Area

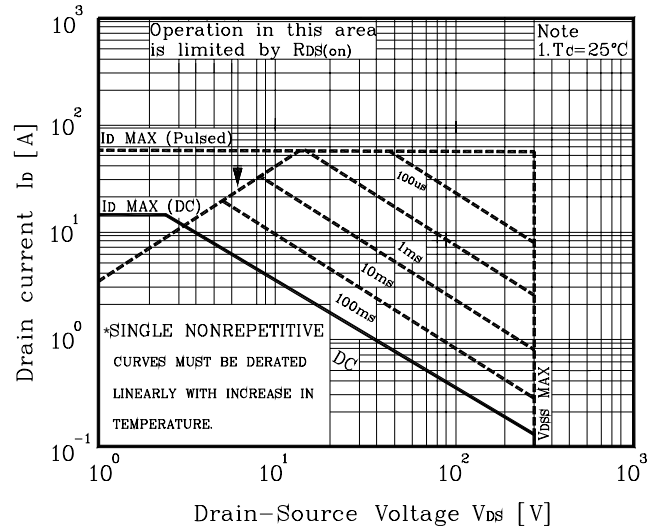

Fig. 11 Gate Charge Test Circuit & Waveform

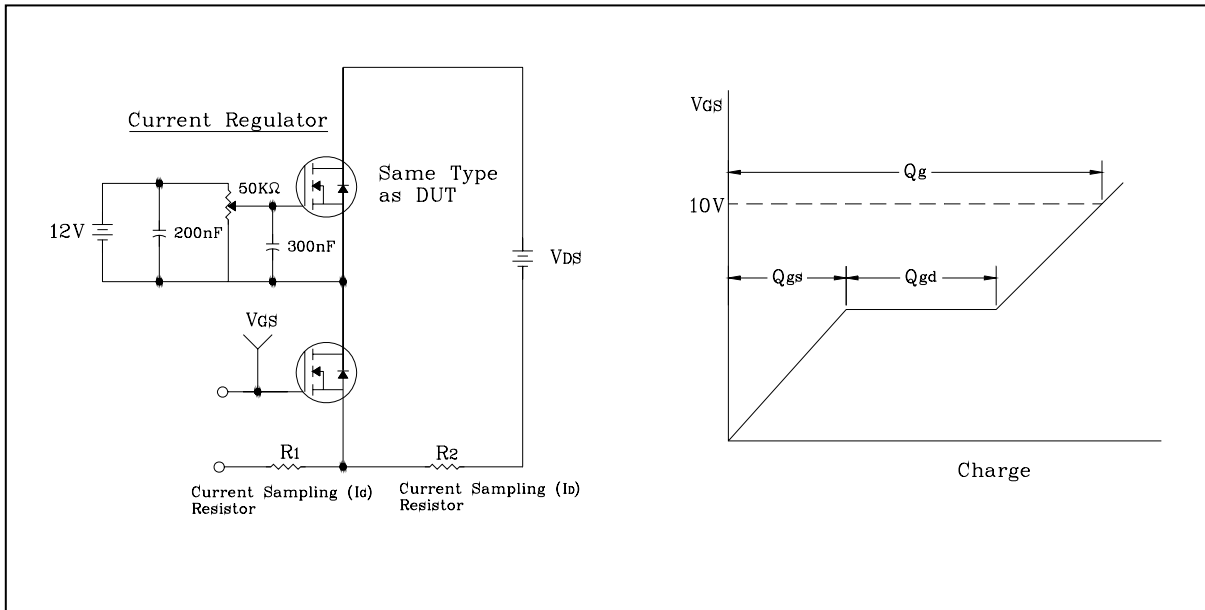

Fig. 12 Resistive Switching Test Circuit & Waveform

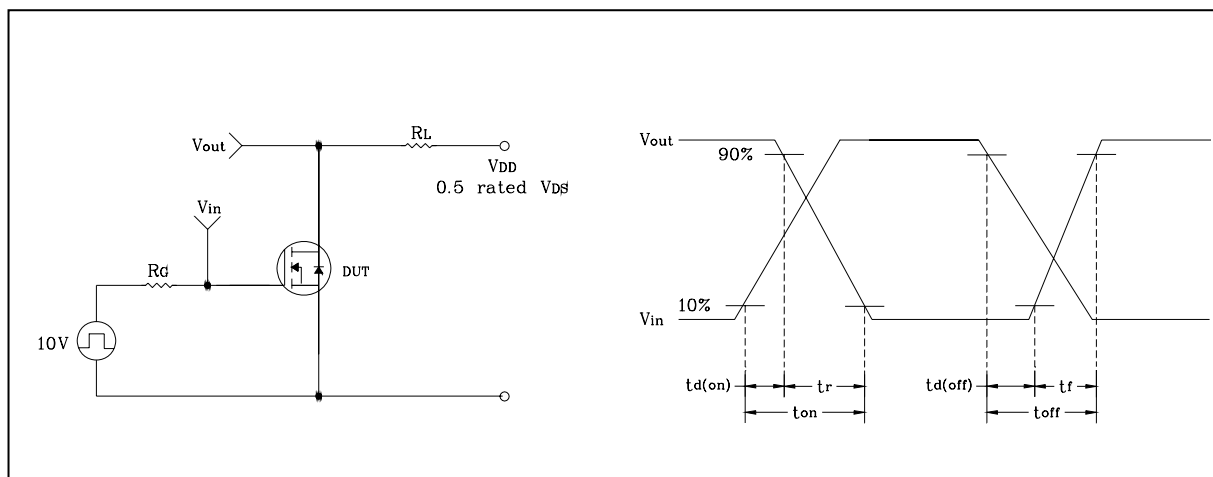

Fig. 13 E_{AS} Test Circuit & Waveform

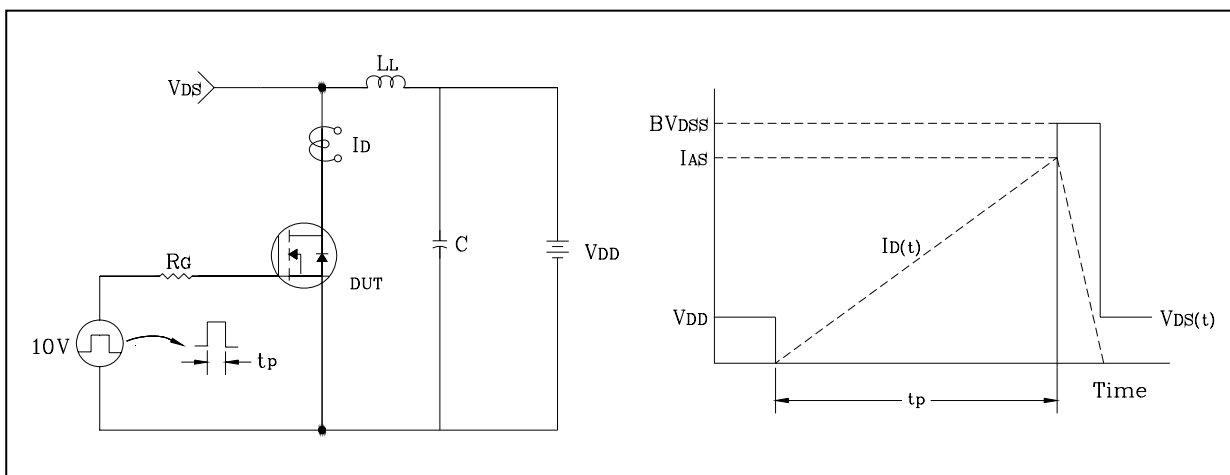
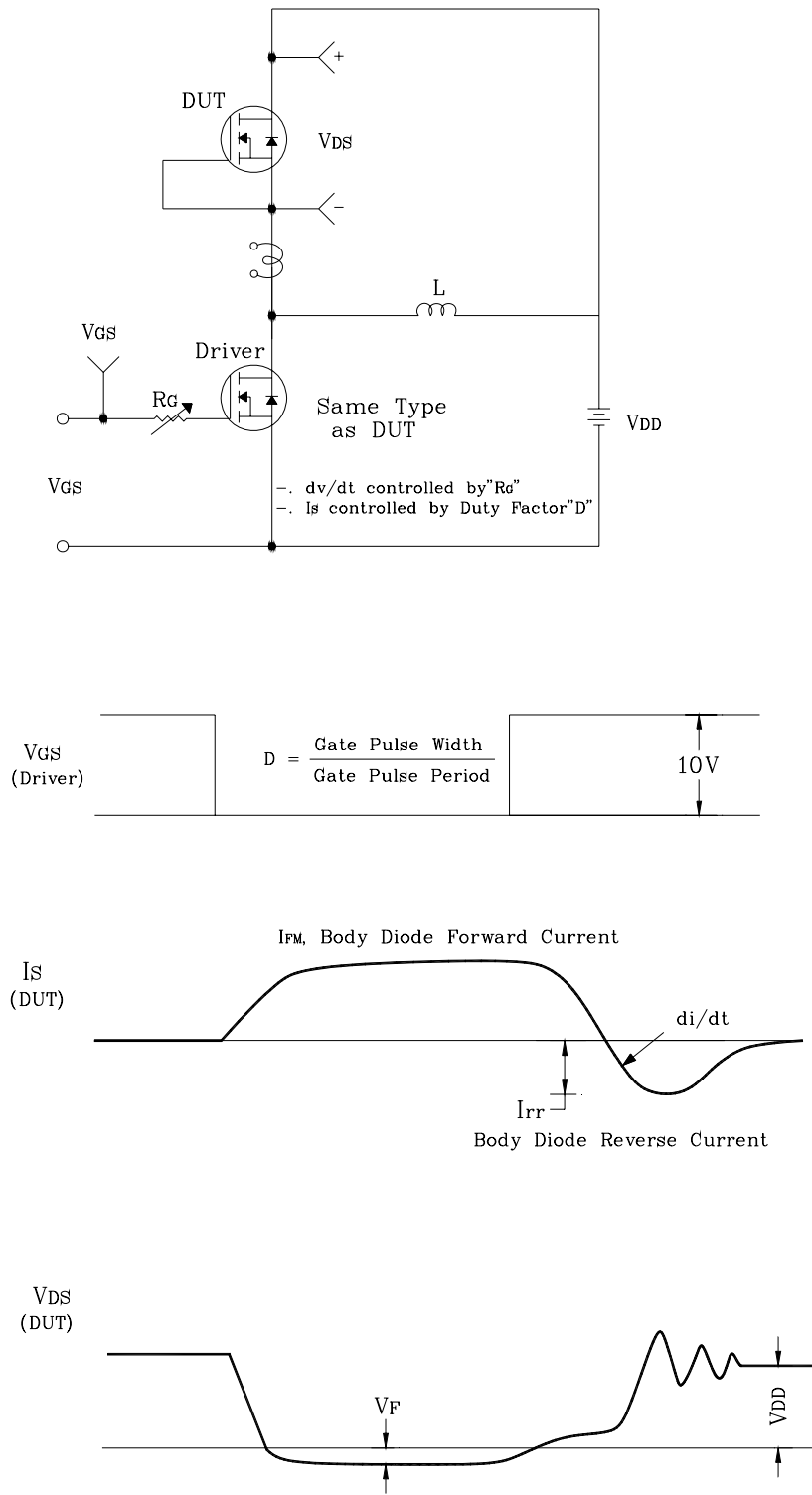

Fig. 14 Diode Reverse Recovery Time Test Circuit & Waveform



X-ON Electronics

Largest Supplier of Electrical and Electronic Components

Click to view similar products for [MOSFET](#) category:

Click to view products by [Truesemi](#) manufacturer:

Other Similar products are found below :

[IRFD120](#) [JANTX2N5237](#) [BUK455-60A/B](#) [MIC4420CM-TR](#) [VN1206L](#) [NDP4060](#) [SI4482DY](#) [IPS70R2K0CEAKMA1](#) [SQD23N06-31L-GE3](#)
[TK16J60W,S1VQ\(O](#) [2SK2614\(TE16L1,Q\)](#) [DMN1017UCP3-7](#) [DMN1053UCP4-7](#) [SQJ469EP-T1-GE3](#) [NTE2384](#) [DMC2700UDMQ-7](#)
[DMN2080UCB4-7](#) [DMN61D9UWQ-13](#) [US6M2GTR](#) [DMN31D5UDJ-7](#) [DMP22D4UFO-7B](#) [DMN1006UCA6-7](#) [DMN16M9UCA6-7](#)
[STF5N65M6](#) [IRF40H233XTMA1](#) [STU5N65M6](#) [DMN6022SSD-13](#) [DMN13M9UCA6-7](#) [DMTH10H4M6SPS-13](#) [DMN2990UFB-7B](#)
[IPB80P04P405ATMA2](#) [2N7002W-G](#) [MCAC30N06Y-TP](#) [MCQ7328-TP](#) [BXP7N65D](#) [BXP4N65F](#) [AOL1454G](#) [WMJ80N60C4](#) [BXP2N20L](#)
[BXP2N65D](#) [BXT1150N10J](#) [BXT1700P06M](#) [TSM60NB380CP](#) [ROG](#) [RQ7L055BGTCR](#) [DMNH15H110SK3-13](#) [SLF10N65ABV2](#)
[BSO203SP](#) [BSO211P](#) [IPA60R230P6](#) [IPA60R460CE](#)