

# Single Turn Trimmer

## Model 23



### Features:

- 4 mm square
- Sealed single turn
- Cermet
- Surface mount

## Electrical

|                               |  |
|-------------------------------|--|
| Standard Resistance Range     | 100 Ohms to 2 Megohms                          |
| Standard Resistance Tolerance | ±20%   |
| Input Voltage                 | 200 Vdc Max. or rms not to exceed power rating |
| Power Rating                  | 0.25 Watts at 70°C derating to 0 at 125°C      |
| End Resistance                | 1% or 3 Ohms Max., whichever is greater        |
| Actual Electrical Travel      | 200° nominal                                   |
| Dielectric Strength           | 500 Vrms                                       |
| Insulation Resistance         | 100 Megohms Min.                               |
| Resolution                    | Essentially infinite                           |
| Contact Resistance Variation  | 2% or 3 Ohms Max., whichever is greater        |

## Environmental

|                             |   |
|-----------------------------|---|
| Seal                        | 85°C Fluorinert® (No Leaks)                       |
| Temperature Coefficient     | ±100 ppm/°C (<200 Ohms or >1Meg = ±250 ppm/°C)    |
| Operating Temperature Range | -55°C to +125°C                                   |
| Thermal Shock               | Five cycles -55°C to +125°C (2% ΔRT, 2% ΔVR)      |
| Moisture Resistance         | Ten 24 hour cycles (3% ΔRT)                       |
| Shock                       | 6 ms sawtooth, 100 G's (1% ΔRT, 1% ΔVR)           |
| Vibration                   | 20 G's, 10 to 2,000 Hz (1% ΔRT, 1% ΔVR)           |
| High Temperature Exposure   | 250 hours at 125°C (2% ΔRT, 2% ΔVR)               |
| Rotational Life             | 100 cycles (5% ΔRT)                               |
| Load Life                   | 1,000 hours at 70°C & 0.25 Watts (3% ΔRT, 1% ΔVR) |
| Resistance to Solder Heat   | 260°C for 10 sec. (1% ΔRT)                        |

## Mechanical

|                  |                                |
|------------------|--------------------------------|
| Mechanical Stops | Solid                          |
| Stop Strength    | 4 oz.-in. Min. (300 g-cm)      |
| Torque           | 2 oz.-in. Max. (150 g-cm)      |
| Weight           | 0.005 oz. nominal (0.14 grams) |

General Note  
TT Electronics reserves the right to make changes in product specification without notice or liability. All information is subject to TT Electronics' own data and is considered accurate at time of going to print.

© TT electronics plc

TT Electronics | BI Technologies  
413 Rood RD, Suite 7  
Calexico, CA 92231  
Ph: + 1 (714) 447-2345  
www.ttelectronics.com/bi-technologies  
Issue B 04/2019 Page 1

### Ordering Information

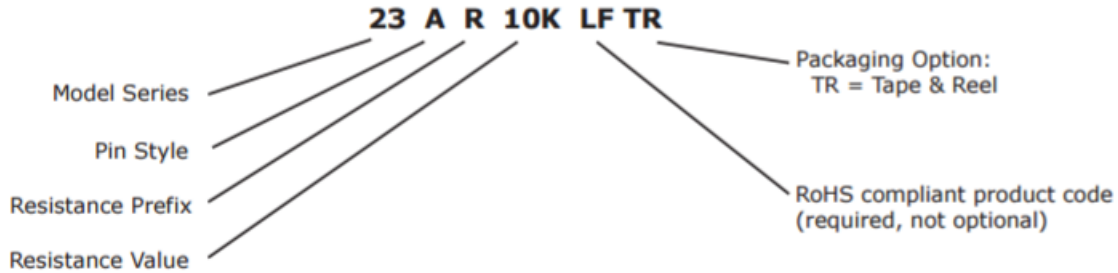

### Packaging Information

Standard (no code): Boxes. Capacity = 100 units.

Option (TR code): Tape & Reel. All units oriented with #2 (slider) pin adjacent to sprocket holes.

|      | Pin Style  | A,B         | S            |
|------|------------|-------------|--------------|
| Tape | Width =    | 12 mm       | 12 mm        |
|      | Sprocket = | 4 mm pitch  | 4 mm pitch   |
|      | Capacity = | 500 units   | 750 units    |
| Reel | Diameter = | 7" (178 mm) | 10" (254 mm) |

### Circuit Diagram

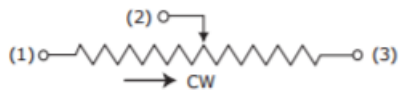

### Standard Resistance Values, Ohms

|     |    |     |      |      |
|-----|----|-----|------|------|
| 100 | 1K | 10K | 100K | 1Meg |
| 200 | 2K | 20K | 200K | 2Meg |
| 500 | 5K | 50K | 500K |      |

### RECOMMENDED PCB LAYOUT

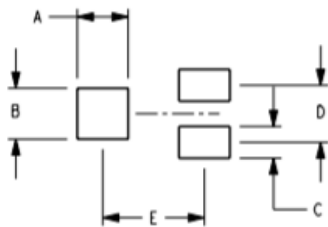

#### Inch/mm

|   | 23A                 | 23B                | 23S                 |
|---|---------------------|--------------------|---------------------|
| A | $\frac{.079}{2.00}$ | $\frac{.051}{1.3}$ | $\frac{.079}{2.0}$  |
| B | $\frac{.079}{2.00}$ | $\frac{.079}{2.0}$ | $\frac{.079}{2.0}$  |
| C | $\frac{.051}{1.3}$  | $\frac{.051}{1.3}$ | $\frac{.051}{1.3}$  |
| D | $\frac{.091}{2.3}$  | $\frac{.091}{2.3}$ | $\frac{.10}{2.54}$  |
| E | $\frac{.157}{4.00}$ | $\frac{.217}{5.5}$ | $\frac{.137}{3.48}$ |

### THROUGH HOLE

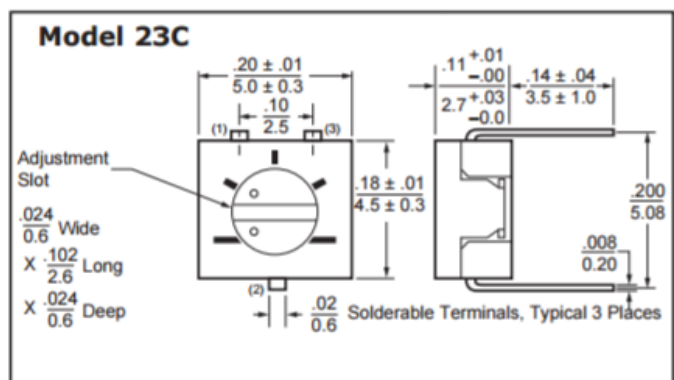

#### General Note

TT Electronics reserves the right to make changes in product specification without notice or liability. All information is subject to TT Electronics' own data and is considered accurate at time of going to print.

### Outline Drawings

#### TOP ADJUSTMENT

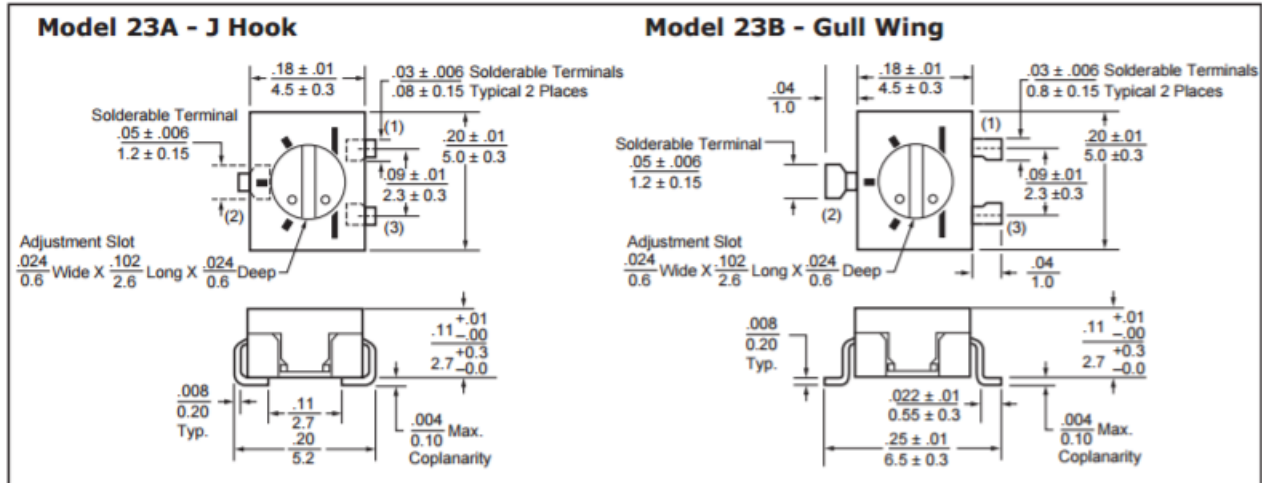

#### SIDE ADJUSTMENT

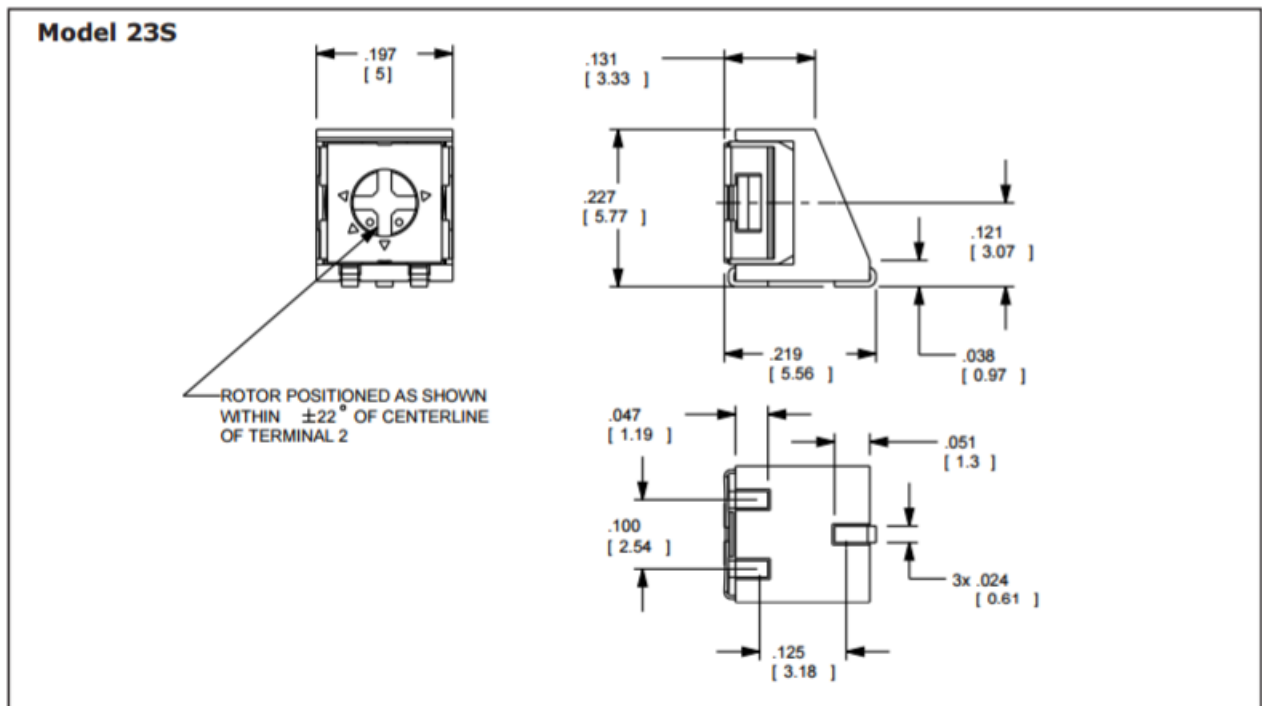

## X-ON Electronics

Largest Supplier of Electrical and Electronic Components

*Click to view similar products for [TT Electronics](#) manufacturer:*

Other Similar products are found below :

[L061S391LF](#) [L091S224LF](#) [L061S220LF](#) [BCN164A562J7](#) [62PR25KLF](#) [56BW-FIFTY-PKG](#) [CHP1501R00FLF](#) [BCN164AB470J7](#) [898-3-R150K](#) [66XR10](#) [66XR200K](#) [66XR2K](#) [66XR50](#) [67WR1MEG](#) [67WR200KLFTB](#) [67ZR200](#) [68WR5K](#) [68XR2MEG](#) [72PXR10K](#) [72XR2.5K](#) [8109](#) [82PR25K](#) [84WR10KTR](#) [OPB660N](#) [OPB748WZ](#) [OPB870T55](#) [OPI1266](#) [P110KV1-0Y20BR50K](#) [JANTX4N24A](#) [89XHR10K](#) [L083C101](#) [91XR5K](#) [SML100M12MSF](#) [PFC-W0805LF-03-2870-B](#) [2627](#) [CR200L.5](#) [RC07GF220J](#) [RC20GF272J](#) [RC55LF-D-196R-B-B](#) [HM00-01800](#) [HM71-10220LFTR](#) [3371R5KL.25](#) [L083C122](#) [W23-330RJI](#) [WH25-47RJI](#) [040585XM](#) [6679-420-0](#) [OP231](#) [OPB471T11](#) [OPB817Z](#)