

Single-In-Line Conformal Coated Diode Array

D Series

- 4 to 14 Leads
- Standard and custom circuits
- Space saving design



 All parts are Pb-free and comply with EU Directive 2011/65/EU amended by (EU) 2015/863 (RoHS3)

Specification

Reverse Voltage, V_R	80V
Reverse Current, I_R	1.0 μ A ($V_R = 70V$)
Forward Current, I_F	100mA Average, 300mA Surge (1 μ s Max.)
Forward Voltage, V_F	1.2V @ $I_F = 100mA$
Package Power, P_{PKG}	200mW @ 25°C
Reverse Recovery Time, t_{rr}	4ns ($V_R = 6V$, $I_F = 5mA$, $R_L = 50\Omega$)
Capacitance, C	5.5pF ($V_R = 6V$, $f = 1MHz$)
Storage Temperature Range	- 55°C to 125°C
Operating Temperature Range	- 25°C to 80°C

General Note

TT Electronics reserves the right to make changes in product specification without notice or liability. All information is subject to TT Electronics' own data and is considered accurate at time of going to print.

D Series

Specification

Circuit Type	Polarity "A"	Polarity "C"
<p>1 N = 4 to 14</p>		
<p>2 N = 3 to 13 (Odd #)</p>		
<p>3 N = 4 to 14 (Even #)</p>		
<p>5 N = 4 to 14</p>		

General Note

TT Electronics reserves the right to make changes in product specification without notice or liability. All information is subject to TT Electronics' own data and is considered accurate at time of going to print.

D Series

Outline Dimensions (Inch/mm)

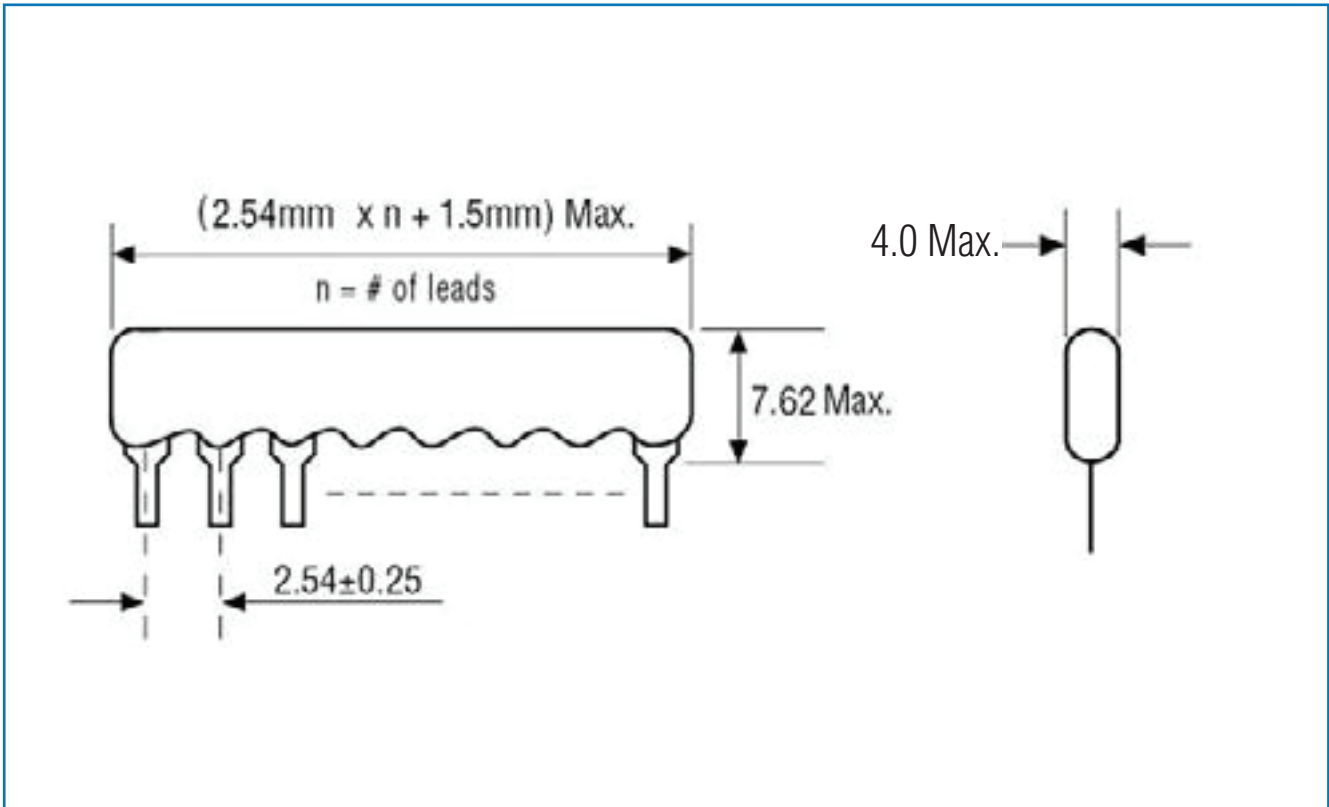

Typical Part Marking

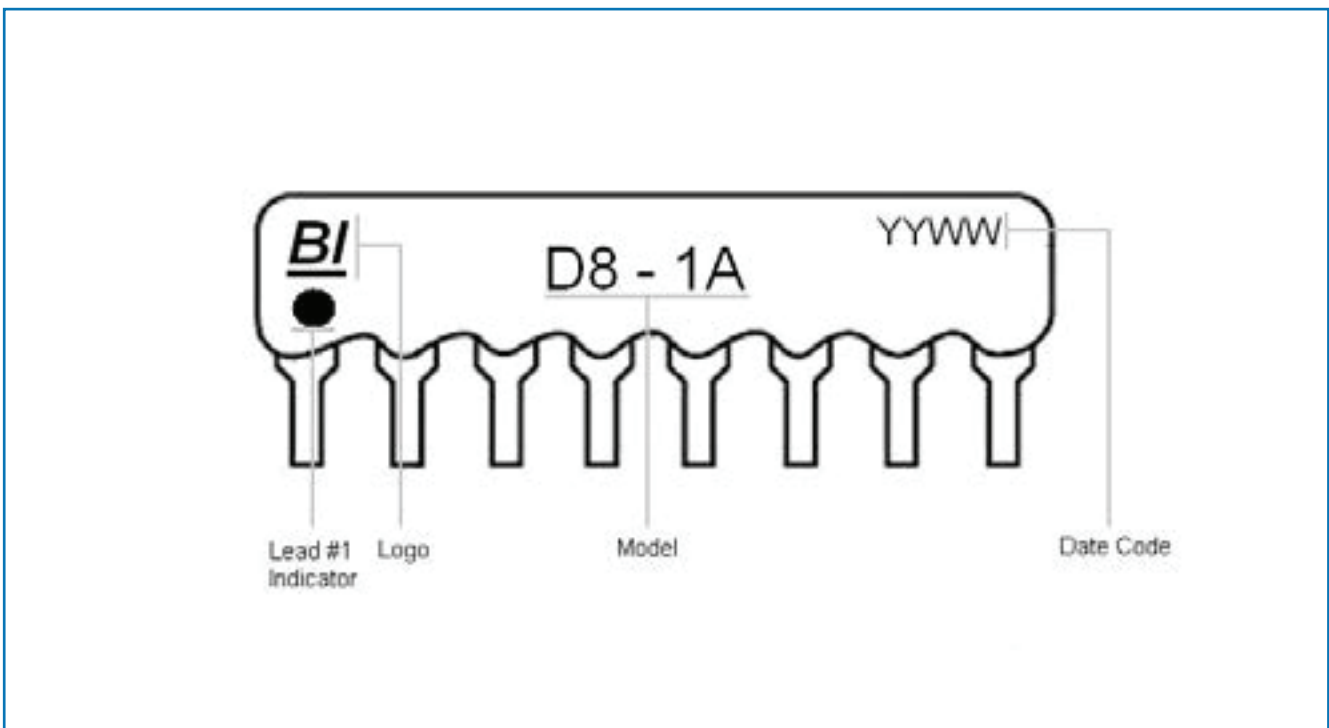

General Note

TT Electronics reserves the right to make changes in product specification without notice or liability. All information is subject to TT Electronics' own data and is considered accurate at time of going to print.

D Series

Ordering Information

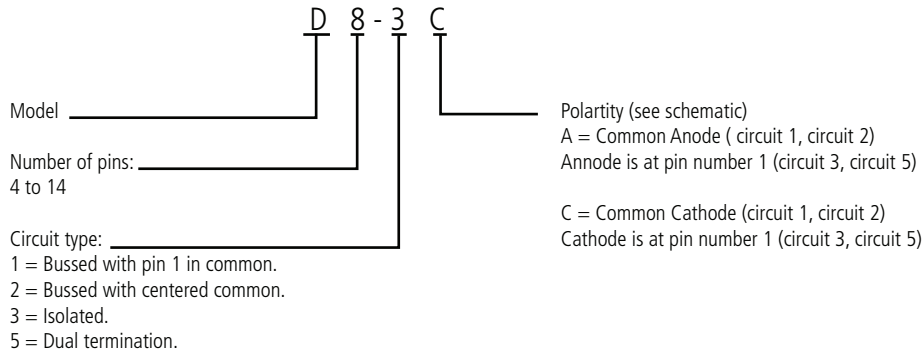

Material

Part	Material
Substrate	Alumina ceramic
Diode	Small mold package silicon epitaxial planar diode array
Termination	100% Ag
Lead Pins	100% Sn Plated steel
Junction and Lead Pin finish	96%Sn, 3.5%Ag, 0.5%Cu
Conformal Coat	Epoxy resin, UL-94 V-0 rated

Packaging

All sizes of D series product are packed in boxes of 200 pieces.

General Note

TT Electronics reserves the right to make changes in product specification without notice or liability.
All information is subject to TT Electronics' own data and is considered accurate at time of going to print.

X-ON Electronics

Largest Supplier of Electrical and Electronic Components

Click to view similar products for [Schottky Diodes & Rectifiers](#) category:

Click to view products by [TT Electronics](#) manufacturer:

Other Similar products are found below :

[CUS06\(TE85L,Q,M\)](#) [MA4E2039](#) [D1FH3-5063](#) [MBR0530L-TP](#) [MBR10100CT-BP](#) [MBR30H100MFST1G](#) [MMBD301M3T5G](#) [PMAD1103-LF](#) [PMAD1108-LF](#) [RB160M-50TR](#) [RB520S-30](#) [RB551V-30](#) [DD350N18K](#) [DZ435N40K](#) [DZ600N16K](#) [BAS16E6433HTMA1](#) [BAS 3010S-02LRH E6327](#) [BAT 54-02LRH E6327](#) [IDL02G65C5XUMA1](#) [NSR05F40QNXT5G](#) [NSVR05F40NXT5G](#) [JANS1N6640](#) [SB07-03C-TB-H](#) [SB1003M3-TL-W](#) [SBAT54CWT1G](#) [SBM30-03-TR-E](#) [SBS818-TL-E](#) [SK32A-LTP](#) [SK33A-TP](#) [SK34A-TP](#) [SK34B-TP](#) [SMD1200PL-TP](#) [ACDBN160-HF](#) [SS3003CH-TL-E](#) [STPS30S45CW](#) [PDS3100Q-7](#) [GA01SHT18](#) [CRS10I30A\(TE85L,QM\)](#) [MBR1240MFST1G](#) [MBRB30H30CT-1G](#) [BAS28E6433HTMA1](#) [BAS 70-02L E6327](#) [HSB123JTR-E](#) [JANTX1N5712-1](#) [VS-STPS40L45CW-N3](#) [DD350N12K](#) [SB007-03C-TB-E](#) [SB10015M-TL-E](#) [SB1003M3-TL-E](#) [SK110-LTP](#)