

# Hallogic Hall-effect Sensor Assembly OHB900

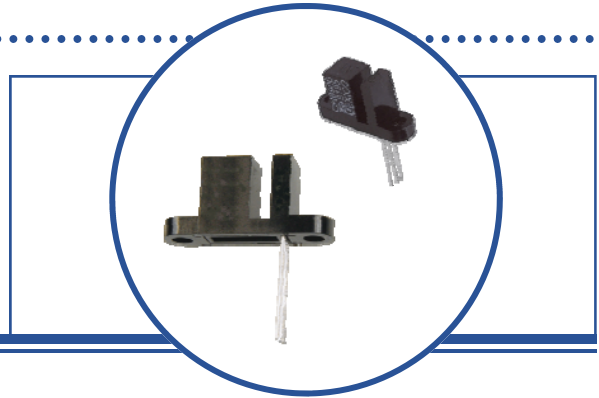

## Features:

- Non-contact motion sensing
- Operates over a broad range of supply voltages (4.5 V to 25 V)
- Excellent temperature stability
- Hall element, linear amplifier and Schmitt trigger on a single Hallogic silicon chip
- Performs in dirty environments over wide temperature range
- 0.125" (3.18 mm) wide gap



## Description:

The OHB900 consists of a Hall-effect sensor similar to the OH180U and a rare earth magnet mounted in a low-cost plastic housing. The magnet produces optimum magnetic flux at the Hall-effect sensor location. The sensor has an open collector transistor output, which is activated when the slot is open. When the slot is blocked by a ferrous material that reduces the magnetic flux density at the Hall-effect sensor location, the open collector output transistor switches off. The device provides up to 25 mA of sink current. Output characteristics are constant at switching frequencies from DC to over 200 kHz.

The Uni-Polar turns on with a (logic level "0") after a sufficient magnetic field from the south pole of a magnet approaches the symbolized face of the device (Operating Point) and turns off (logic level "1") after the magnetic field reached a minimum value. This feature makes these sensors ideal for applications in non-contact switching operations.

## Applications:

- Non-contact slotted magnetic switch
- Harsh environment encoder
- Assembly line automation
- Machine automation
- Machine safety
- End of travel sensor
- Door sensor

Ordering Information	
Part Number	Description
OHB900	Slotted Switch

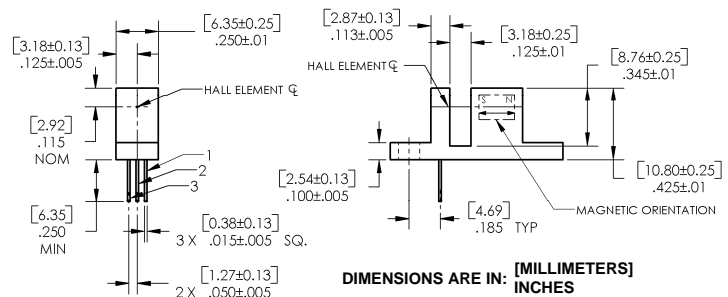
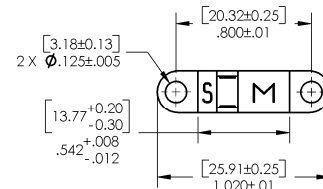

DIMENSIONS ARE IN: [MILLIMETERS]  
INCHES

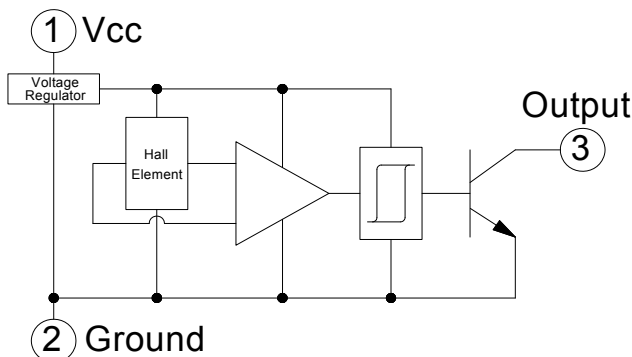

Pin #	Description
1	Vcc
2	Ground
3	Output



RoHS

OPTEK reserves the right to make changes at any time in order to improve design and to supply the best product possible.

**Absolute Maximum Ratings** (TA = 25° C unless otherwise noted)

Supply Voltage, V <sub>CC</sub>	25 V
Storage Temperature Range, T <sub>S</sub>	-50°C to +160° C
Operating Temperature Range, T <sub>A</sub>	-40°C to +150° C
Lead Soldering Temperature (1/8 in. (3.2 mm) from case for 5 sec. with soldering iron)	260° C
Output ON Current, I <sub>SINK</sub>	25 mA
Output OFF Voltage, V <sub>OUT</sub>	25 V
Magnetic Flux Density, B	Unlimited

**Electrical Characteristics** (V<sub>CC</sub> = 4.5 V to 24 V, T<sub>A</sub> = 25° C unless otherwise noted)<sup>(2)</sup>

SYMBOL	PARAMETER	MIN	TYP	MAX	UNITS	TEST CONDITIONS
I <sub>CC</sub>	Supply Current	-	4	7	mA	V <sub>CC</sub> = 24 V, Output Off
V <sub>OL</sub>	Output Saturation Voltage	-	100	400	mV	V <sub>CC</sub> = 4.5 V, I <sub>OL</sub> = 20 mA, Slot Open
I <sub>OH</sub>	Output Leakage Current	-	0.1	10	µA	V = 4.5 V, V <sub>OUT</sub> = 24 V, Slot Blocked <sup>(1)</sup>
t <sub>r</sub>	Output Rise Time	-	0.21	1	µs	R <sub>L</sub> = 820 Ω, C <sub>L</sub> = 20 pF
t <sub>f</sub>	Output Fall Time	-	0.1	1	µs	R <sub>L</sub> = 820 Ω, C <sub>L</sub> = 20 pF

Notes:

- (1) Slot blocked with a ferrous material to interrupt magnetic flux.
- (2) See Hall-effect data sheet OH090 through OHS3100 Series for additional information — for reference only.

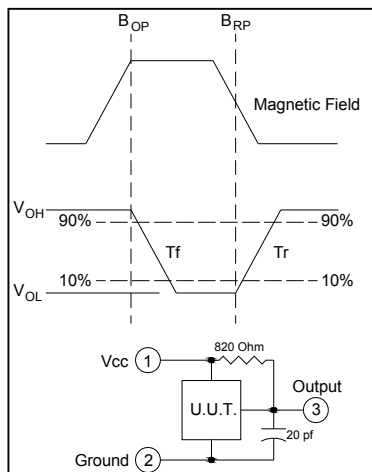

	Right Operate Point	Right Release Point	Left Release Point	Left Operate Point
Minimum	0.073" [1,85mm]	0.045" [1,14mm]	-0.045" [-1,14mm]	-0.073" [-1,85mm]
Maximum	0.003" [0,08mm]	-0.005" [-0,127mm]	0.005" [0,127mm]	-0.003" [-0,08mm]

Measurements are referenced to Center Line.

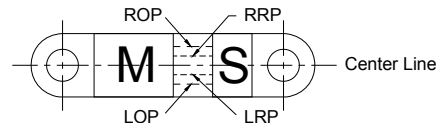

Vane - Material = 1018 Cold Rolled Steel - 0.03" [0.76mm] Thick  
 Location = 0.50" [12.7mm] from Bottom of Slot

OPTeK reserves the right to make changes at any time in order to improve design and to supply the best product possible.

**Rise & Fall vs Temperature**

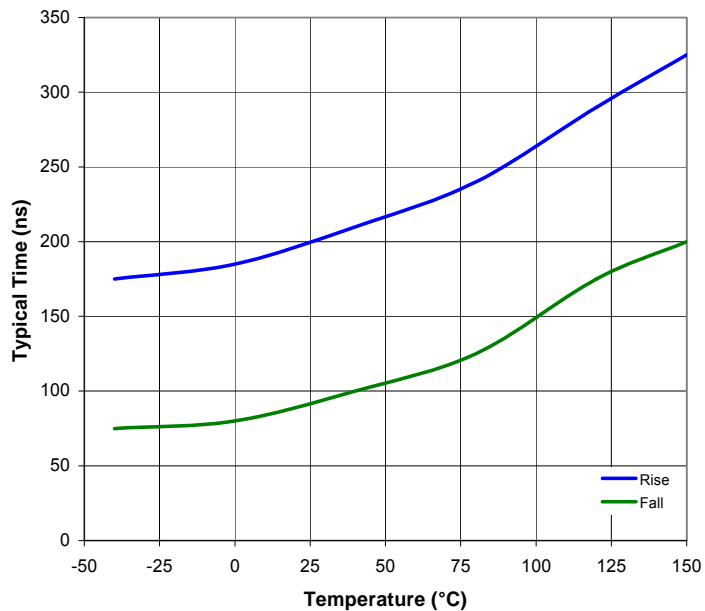

**Icc vs Temperature**

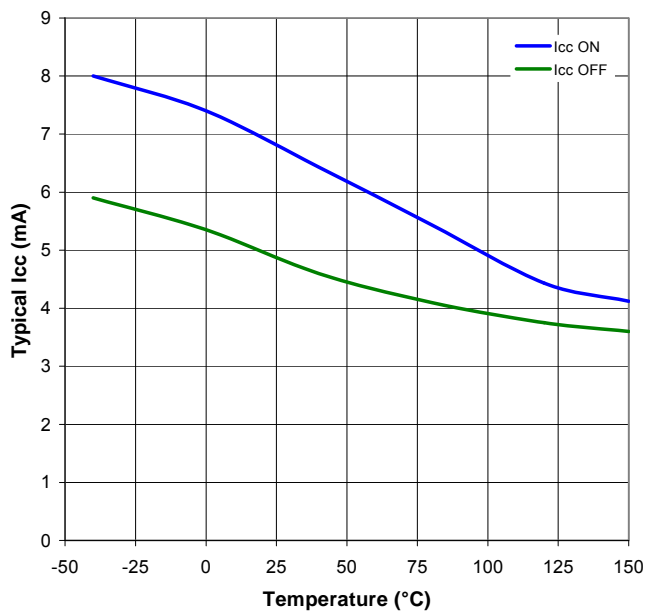

**Saturation Voltage vs Temperature**

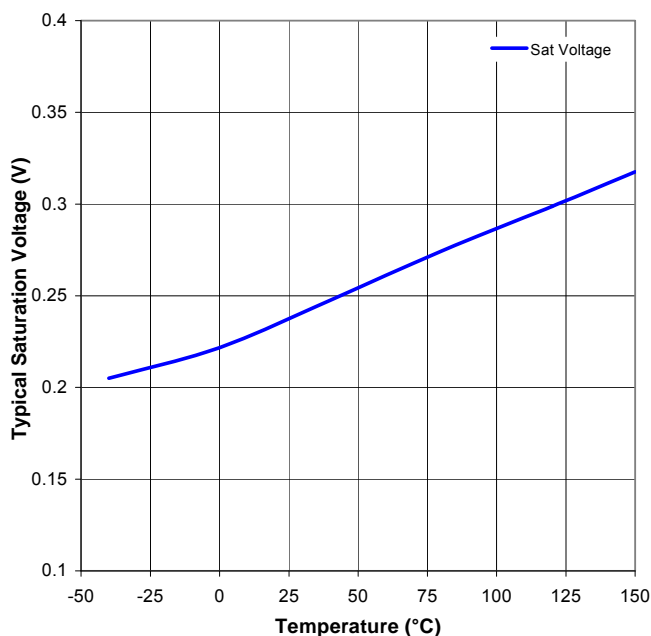

OPTEK reserves the right to make changes at any time in order to improve design and to supply the best product possible.

## X-ON Electronics

Largest Supplier of Electrical and Electronic Components

*Click to view similar products for [Board Mount Hall Effect/Magnetic Sensors](#) category:*

*Click to view products by [TT Electronics](#) manufacturer:*

Other Similar products are found below :

[HGPRDT005A](#) [AH1808-P-A](#) [AH277AZ4-AG1](#) [AV-10379](#) [AV-10448](#) [SS41C](#) [AH1894-Z-7](#) [ATS601LSGTN-LT-WU4-T](#) [TLE4917](#)  
[50017859-003](#) [TY-13101](#) [TLE4976L](#) [SS85CA](#) [AH277AZ4-BG1](#) [TLE49614MXTSA1](#) [AH3377-P-B](#) [AH211Z4-AG1](#) [AH3360-FT4-7](#)  
[SS460S-100SAMPLE](#) [50065820-03](#) [TLE4941PLUSCB](#) [AH374-P-A](#) [AH1806-P-A](#) [AH374-W-7](#) [SS460P-T2](#) [SS413F](#)  
[TLE5046ICAKLRHALA1](#) [TLE49421CHAMA2](#) [TLE4941PLUSCXAMA1](#) [AH1912-W-EVM](#) [AH1903-FA-EVM](#) [AH3774-W-EVM](#)  
[AH49FNTR-EVM](#) [MMC5633NJL](#) [AH3360-FA-EVM](#) [AH8502-FDC-EVM](#) [AH3366Q-SA-EVM](#) [AH3774-P-EVM](#) [KTH1601SU-ST3](#)  
[MG910](#) [MG910M](#) [MG911](#) [MG610](#) [MW921](#) [MW922](#) [TLE4998S3XALA1](#) [TLE5011FUMA1](#) [TLE5027CE6747HAMA1](#)  
[TLE5109A16E1210XUMA1](#) [TLE5109A16E2210XUMA1](#)