

**Features:**

- Ratiometric linear output capable of sinking and sourcing current
- 4.5 V to 6.0 V operation
- Responds equally to positive and negative magnetic fields
- Excellent temperature stability to operate in harsh environments
- Robust package capable of withstanding harsh environments

Description:

Each ratiometric linear Hall-effect sensor contains a monolithic integrated circuit on a single chip. This circuit incorporates a quadratic Hall sensing element, which minimizes the effects of mechanical and thermal stress on the Hall element and temperature compensating circuitry to compensate for the inherent Hall element sensitivity change over temperature current.

These ratiometric linear Hall-effect sensors provide an output voltage that varies in proportion to the applied magnetic field. The voltage output will increase in response to a south pole (positive) magnetic field applied perpendicular to the package symbolization face, and will decrease in response to a north pole (negative) magnetic field.

These ratiometric linear Hall-effect sensors can be used as a non-contact sensor for rotary and linear position sensing and for current sensing.

Applications:

- Non-contact magnetic sensing
- Assembly line automation
- Machine automation
- Machine safety
- Door sensor
- Where sensing is required in dirty environments

Ordering Information		
Through Hole	Temp. Range	V _{OQ} Threshold
OHS3150U	-40°C to +125°C	V _{OQ} Change over T _A = ±35 Gauss
OHS3151U	-40°C to +125°C	V _{OQ} Change over T _A = ±50 Gauss

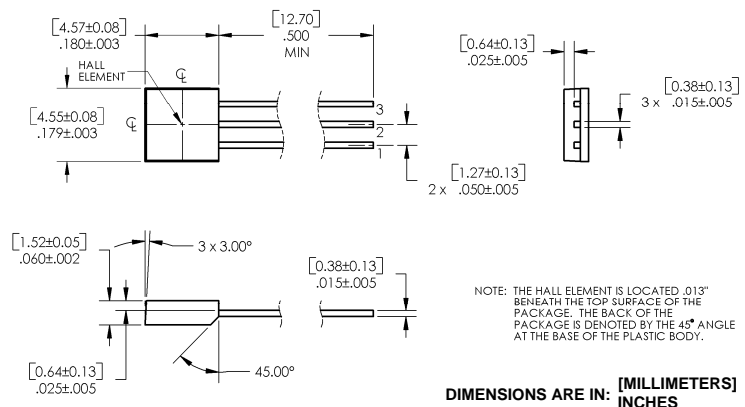
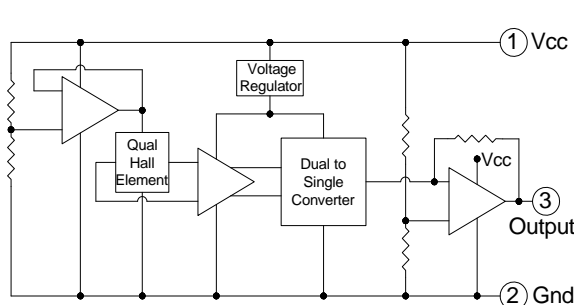

RoHS

General Note

TT Electronics reserves the right to make changes in product specification without notice or liability. All information is subject to TT Electronics' own data and is considered accurate at time of going to print.



1645 Wallace Drive, Carrollton, TX 75006 | Ph: +1 972 323 2200
 www.optekinc.com | www.ttelectronics.com

Absolute Maximum Ratings

Supply Voltage, V_{CC}	6 V
Storage Temperature Range, T_S	-65°C to +150°C
Operating Temperature Range, T_A	-40°C to +125°C
Lead Soldering Temperature (1/8 inch [3.2 mm] from case for 5 seconds with soldering iron)	260°C ⁽¹⁾
Power Dissipation, P_D	100 mW
Output Current, I_O	5 mA
Magnetic Flux Density, B	Unlimited

Electrical Characteristics (Over Operating Temperature Range at $V_{CC} = 5 V$, unless otherwise noted)

SYMBOL	PARAMETER	MIN	TYP	MAX	UNITS	TEST CONDITIONS
V_{CC}	Supply Voltage	4.5	5.0	6.00	V	
I_{CC}	Supply Current		5.5	10.00	mA	$V_{CC} = 6 V, I_O = 0 mA, B = OG$
V_{OQ}	Quiescent Voltage Output	2.25	2.5	2.75	V	$B = OG, T_A = 25^\circ C$
		2.10	2.5	2.90	V	$B = OG, T_A = -40^\circ C \text{ to } +125^\circ C$
I_O	Sink Current	0.5			mA	
I_O	Source Current	-1.0			mA	

SYMBOL	PARAMETER	OHS3150U			UNITS	OHS3151U			UNITS
		MIN	TYP	MAX		MIN	TYP	MAX	
T_A	Operating Temperature Range	-40	-	125	°C	-40	-	125	°C
Sens	Sensitivity @ $T_A = 25^\circ C$ over T_A	2.25 2.0	2.5 -	2.75 3.0	mV/G mV/G	2.25 2.0	2.5 -	2.75 3.0	mV/G mV/G
$\Delta Sens(\Delta T)$	Sens Change @ $T_A > 25^\circ C$ @ $T_A < 25^\circ C$	-2 -10	- -	8 0	% %	-2 -10	- -	8 0	% %
$\Delta V_{OQ}(\Delta T)$	V_{OQ} Change over T_A	-	-	±35	G	-	-	±50	G
$\Delta Sens(\Delta V)$	Ratiometric Sense Change	-	100	-	%	-	100	-	%
$\Delta V_{OQ}(\Delta V)$	Ratiometric V_{OQ} Change	-	100	-	%	-	100	-	%
+Lin	Positive Lin ≥ 25 < 25	99 99	- -	105 110	%	99 99	- -	105 110	%
-Lin	Negative Lin ≥ 25 < 25	95 90	- -	101 101	%	95 90	- -	101 101	%
Sym	Output Symmetry	95	100	105	%	95	100	105	%

Note:

- (1) Negative current is defined as a coming out of (sourcing) the output.
- (2) See characteristics definitions for test conditions and calculation formulas.

General Note

TT Electronics reserves the right to make changes in product specification without notice or liability. All information is subject to TT Electronics' own data and is considered accurate at time of going to print.



1645 Wallace Drive, Carrollton, TX 75006 | Ph: +1 972 323 2200
 www.optekinc.com | www.ttelectronics.com

Characteristics Definitions

Quiescent voltage Output: With no magnetic field present the device in the quiescent state and the voltage output is approximately equal to one-half the supply voltage ($V_{OQ} = V_{CC} / 2$) over the operating voltage and temperature range. The change in quiescent voltage output over temperature gives the device's equivalent accuracy and is specified in gauss by the calculation.

$$\Delta V_{OQ} (\text{T}) = \frac{V_{OQ} (\text{TA}) - V_{OQ} (25^{\circ}\text{C})}{\text{Sens} (25^{\circ}\text{C})}$$

Sensitivity: A magnetic south pole at, and perpendicular to, the device's symbolized package face will increase the voltage output above the quiescent value. Conversely a magnetic north pole will decrease the voltage output below the quiescent value. This change in voltage output with applied magnetic field is sensitivity and is specified in mV/G by the calculation.

$$\text{Sens} = \frac{V_{O} (+500\text{G}) - V_{O} (-500\text{G})}{1000}$$

The change in sensitivity over temperature is specified in percent by the calculation

$$\Delta \text{Sens} (\Delta \text{T}) = \frac{\text{Sens} (\text{TA}) - \text{Sens} (25^{\circ}\text{C})}{\text{Sens} (25^{\circ}\text{C})} \times 100\%$$

Ratiometry: The quiescent voltage output and sensitivity of these ratiometric linear Hall-effect devices are proportional to the supply voltage. The change in quiescent voltage output with supply voltage is specified in percent by the calculation

$$\Delta V_{OQ} (\Delta V) = \frac{V_{O} (V_{CC}) - V_{O} (5\text{V})}{V_{CC} / 5\text{V}} \times 100\%$$

This change in sensitivity with supply voltage is also specified in percent by the calculation

$$\Delta \text{Sens} (\Delta V) = \frac{V_{OQ} (V_{CC}) / V_{OQ} (5\text{V})}{V_{CC} / 5\text{V}} \times 100\%$$

Linearity & Symmetry: The ability of the voltage output to vary in constant proportion to the applied magnetic field is linearity and is specified in percent by the calculation

$$+ \text{ Linearity} = \frac{V_{O} (+500\text{G}) - V_{OQ}}{2(V_{O} (250\text{G}) - V_{OQ})} \times 100\%$$

$$- \text{ Linearity} = \frac{V_{O} (-500\text{G}) - V_{OQ}}{2(V_{O} (-250\text{G}) - V_{OQ})} \times 100\%$$

The output is also specified in percent by the calculation

$$- \text{ Linearity} = \frac{V_{O} (500\text{G}) - V_{OQ}}{V_{OQ} - V_{OQ} (-500\text{G})} \times 100\%$$

General Note

TT Electronics reserves the right to make changes in product specification without notice or liability. All information is subject to TT Electronics' own data and is considered accurate at time of going to print.



Output vs Gauss

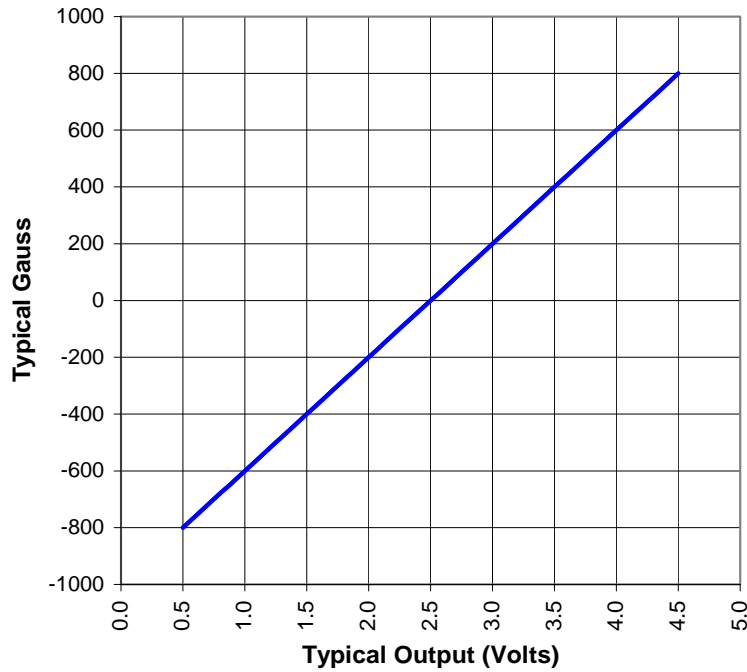

Icc vs Temperature

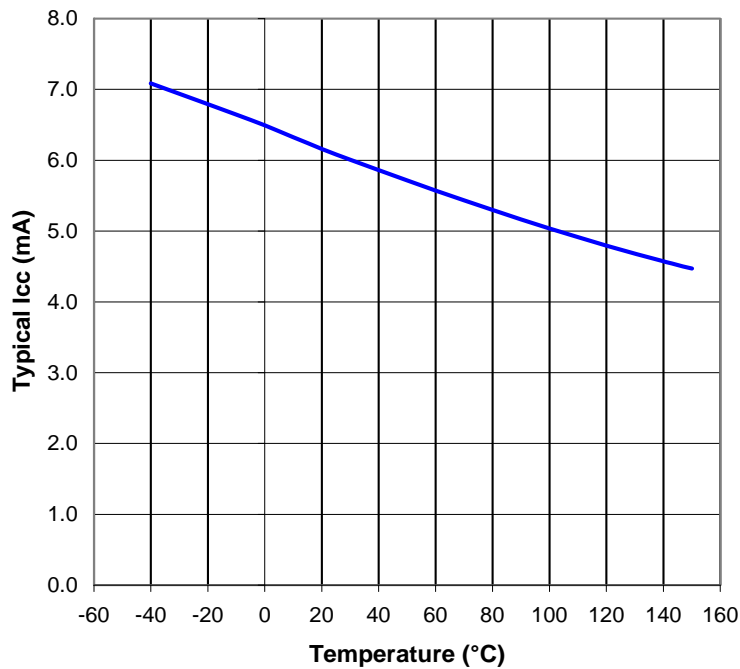

General Note

TT Electronics reserves the right to make changes in product specification without notice or liability. All information is subject to TT Electronics' own data and is considered accurate at time of going to print.



1645 Wallace Drive, Carrollton, TX 75006 | Ph: +1 972 323 2200
www.optekinc.com | www.ttelectronics.com

X-ON Electronics

Largest Supplier of Electrical and Electronic Components

Click to view similar products for [Board Mount Hall Effect/Magnetic Sensors](#) category:

Click to view products by [TT Electronics](#) manufacturer:

Other Similar products are found below :

[HGPRDT005A](#) [AH1808-P-A](#) [AH277AZ4-AG1](#) [AV-10379](#) [AV-10448](#) [SS41C](#) [AH1894-Z-7](#) [ATS601LSGTN-LT-WU4-T](#) [TLE4917](#)
[50017859-003](#) [TY-13101](#) [TLE4976L](#) [SS85CA](#) [AH277AZ4-BG1](#) [TLE49614MXTSA1](#) [AH3377-P-B](#) [AH211Z4-AG1](#) [AH3360-FT4-7](#)
[SS460S-100SAMPLE](#) [50065820-03](#) [TLE4941PLUSCB](#) [AH374-P-A](#) [AH1806-P-A](#) [AH374-W-7](#) [SS460P-T2](#) [SS413F](#)
[TLE5046ICAKLRHALA1](#) [TLE49421CHAMA2](#) [TLE4941PLUSCXAMA1](#) [AH1912-W-EVM](#) [AH1903-FA-EVM](#) [AH3774-W-EVM](#)
[AH49FNTR-EVM](#) [MMC5633NJL](#) [AH3360-FA-EVM](#) [AH8502-FDC-EVM](#) [AH3366Q-SA-EVM](#) [AH3774-P-EVM](#) [KTH1601SU-ST3](#)
[MG910](#) [MG910M](#) [MG911](#) [MG610](#) [MW921](#) [MW922](#) [TLE4998S3XALA1](#) [TLE5011FUMA1](#) [TLE5027CE6747HAMA1](#)
[TLE5109A16E1210XUMA1](#) [TLE5109A16E2210XUMA1](#)