

PIN Silicon Photodiode

OP993, OP999



Features:

- Choice of TO-18 (OP993) or T-1¾ package (OP999)
- Small package style ideal for space-limited applications
- Linear response vs. irradiance
- Fast switching time
- Choice of narrow or wide receiving angle

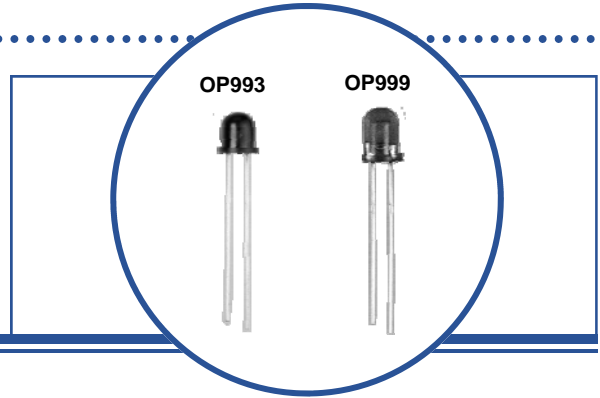

Description:

Each **OP993** and **OP999** device consists of a PIN silicon photodiode molded in a dark blue injection molded shell package that provides excellent optical and mechanical axis alignment, optical lens surface, control of chip placement and consistency of the outside package dimensions.

OP993 has a TO-18 package style and a *wide* receiving angle that provides excellent on-axis coupling. **OP999** has a T-1¾ package style and a *narrow* receiving angle that provides excellent on-axis coupling.

Both devices are 100% production tested for close correlation with OPTEK GaAIAs emitters.

Please refer to Application Bulletins 208 and 210 for additional design information and reliability (degradation) data.

Applications:

- Non-contact reflective object sensor
- Machine automation
- End of travel sensor
- Assembly line automation
- Machine safety
- Door sensor

Ordering Information			
Part Number	Sensor	Viewing Angle	Lead Length
OP993	Photodiode	118°	0.75 min
OP999	Photodiode	18°	

OP993



Pin #	Sensor
1	Cathode
2	Anode

OP993

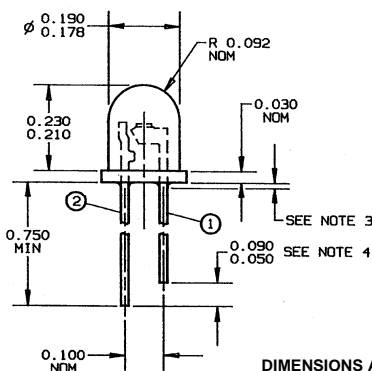

OP999

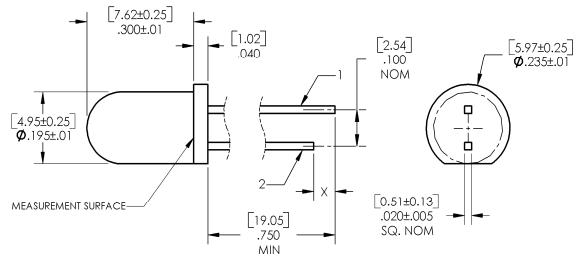

OP999



Pin #	Sensor
1	Anode
2	Cathode



RoHS

OPTEK reserves the right to make changes at any time in order to improve design and to supply the best product possible.

CONTAINS POLYSULFONE
 To avoid stress cracking, we suggest using ND Industries' **Vibra-Tite** for thread-locking. **Vibra-Tite** evaporates fast without causing structural failure in OPTEK'S molded plastics.

Absolute Maximum Ratings ($T_A=25^\circ\text{C}$ unless otherwise noted)

Reverse Breakdown Voltage	60 V
Storage & Operating Temperature Range	-40° C to +100° C
Lead Soldering Temperature [1/16 inch (1.6 mm) from the case for 5 sec. with soldering iron]	260° C ⁽¹⁾
Reverse Breakdown Voltage	60 V
Power Dissipation	100 mW ⁽²⁾

Electrical Characteristics ($T_A=25^\circ\text{C}$ unless otherwise noted)

SYMBOL	PARAMETER	MIN	TYP	MAX	UNITS	TEST CONDITIONS
I_L	Reverse Light Current OP993 OP999	12.5	-	28.5	μA	$V_R = 5\text{ V}, E_E = 1.7\text{ mW/cm}^2$ ⁽³⁾ $V_R = 5\text{ V}, E_E = 0.25\text{ mW/cm}^2$ ⁽³⁾
		6.5	-	15		
I_D	Reverse Dark Current		1	60	nA	$V_R = 30\text{ V}, E_E = 0$ ⁽⁴⁾
$V_{(BR)}$	Reverse Breakdown Voltage	60			V	$I_R = 100\ \mu\text{A}$
V_F	Forward Voltage			1.2	V	$I_F = 1\text{ mA}$
C_T	Total Capacitance		4		pF	$V_R = 20\text{ V}, E_E = 0, f = 1.0\text{ MHz}$
t_r	Rise Time		5		ns	$V_R = 20\text{ V}, \lambda = 850\text{ nm}, R_L = 50\ \Omega$
t_f	Fall Time		5			

Notes:

- (1) RMA flux is recommended. Duration can be extended to 10 seconds maximum when flow soldering. A maximum of 20 grams force may be applied to leads when soldering.
- (2) Derate linearly 1.67 mW/° C above 25° C.
- (3) Light source is an unfiltered GaAIAs emitting diode operating at peak emission wavelength of 890 nm and $E_{E(APT)}$ of 1.7 mW/cm² for OP993 and 0.25mW/cm² for OP999 average within a 0.25" diameter aperture.
- (4) This dimension is held to within ± 0.005 " on the flange edge and may vary up to ± 0.020 " in the area of the leads.

OPTEK reserves the right to make changes at any time in order to improve design and to supply the best product possible.

OP993

Coupling Characteristics
OP993 and OP293

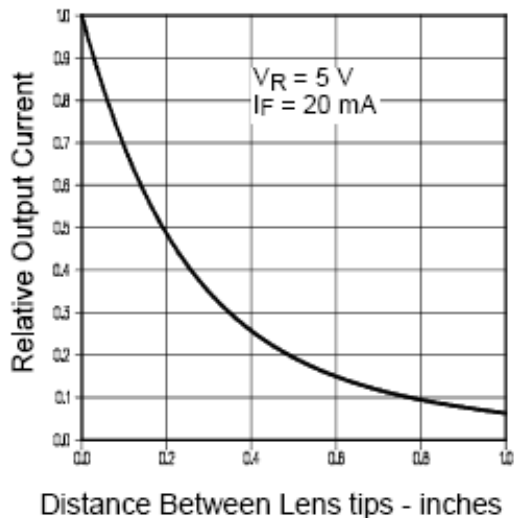

Light Current vs. Irradiance

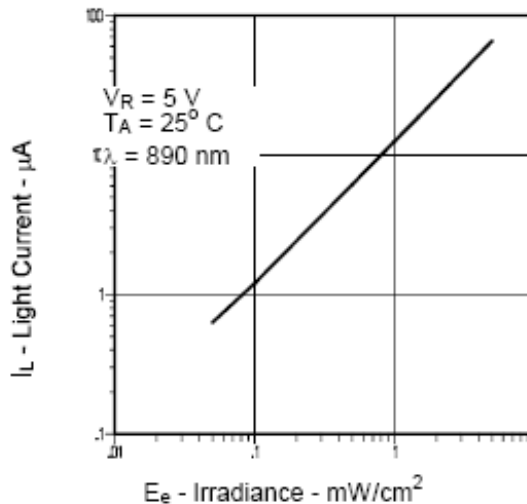

Light Current vs. Angular Displacement

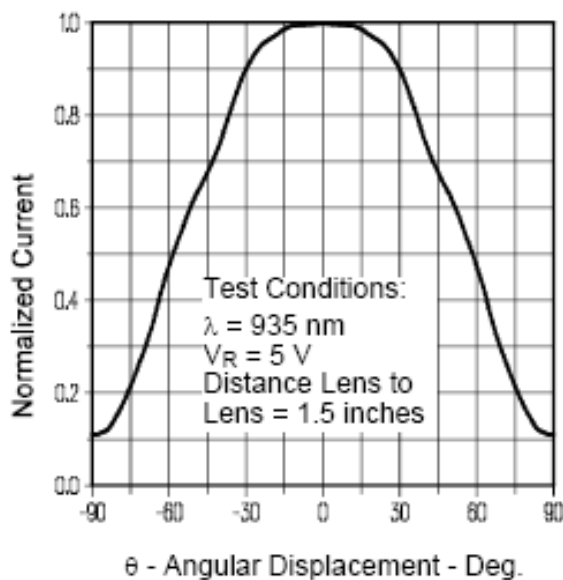

OPTEK reserves the right to make changes at any time in order to improve design and to supply the best product possible.

OP999

**Coupling Characteristics
 OP999 and OP299**

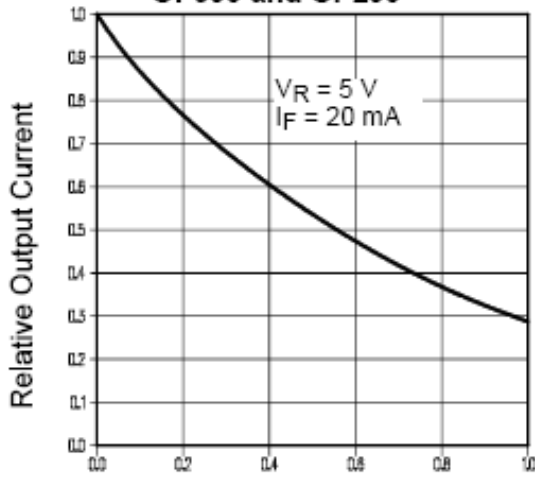

Distance Between Lens Tips - inches

Light Current vs. Irradiance

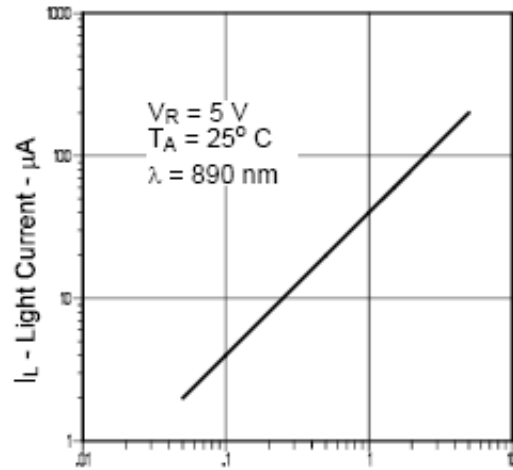

E_e - Irradiance - mW/cm²

Light Current vs. Angular Displacement

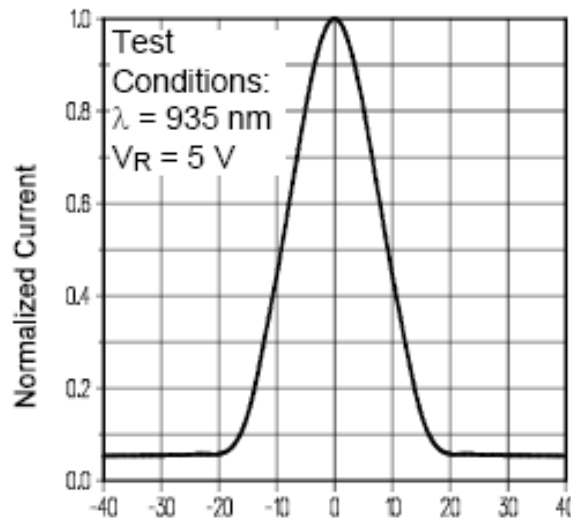

θ - Angular Displacement - Deg.

OPTEK reserves the right to make changes at any time in order to improve design and to supply the best product possible.

Relative Response vs. Wavelength

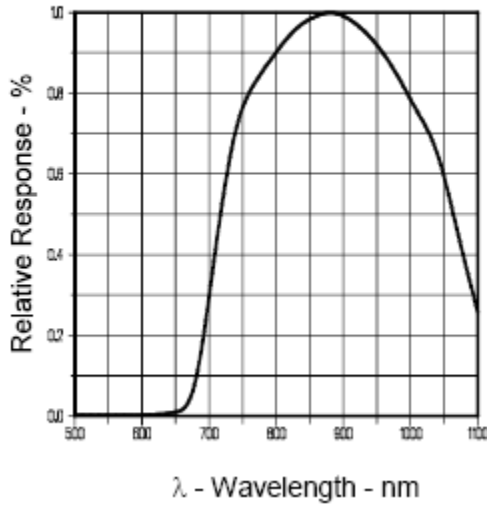

Normalized Light Current vs Reverse Voltage

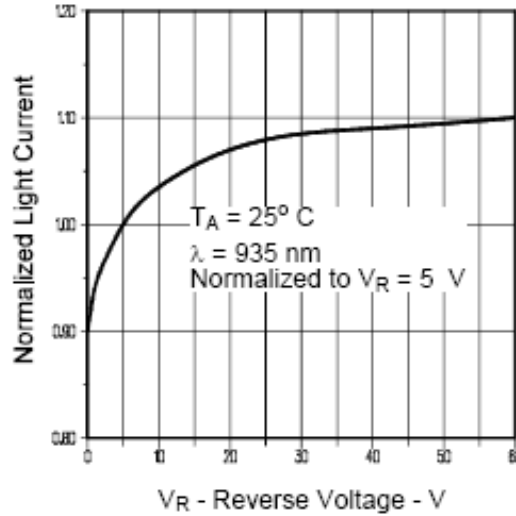

Total Capacitance vs Reverse Voltage

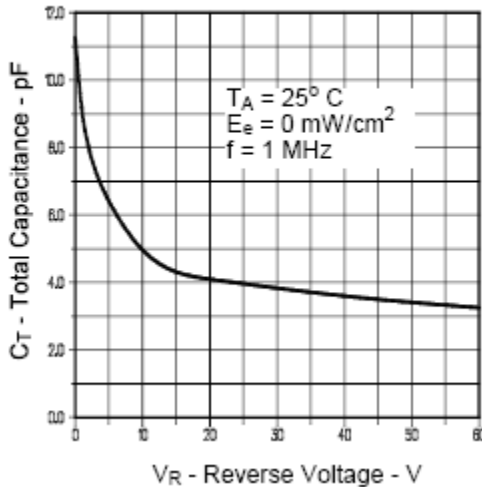

Normalized Light and Dark Current vs Ambient Temperature

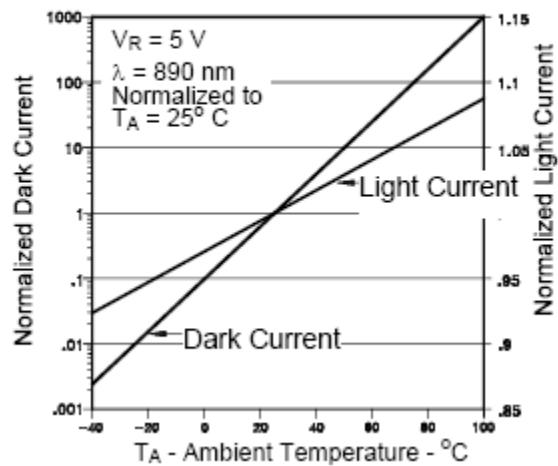

OPTEK reserves the right to make changes at any time in order to improve design and to supply the best product possible.

X-ON Electronics

Largest Supplier of Electrical and Electronic Components

Click to view similar products for [Photodiodes](#) category:

Click to view products by [TT Electronics](#) manufacturer:

Other Similar products are found below :

[LTR-526AD](#) [OED-SP-7L](#) [LTR-536AB](#) [LTR-743DBM1-TA](#) [67-21SYGC-S349-TR8](#) [SFH 2200 A01](#) [HFD3081-108-XBA](#) [BPW 34 S E9601](#)
[SFH 2713](#) [SFH 2703](#) [LTR-546AD](#) [BPV23FL](#) [BPW 34 FAS](#) [BPW 34 FS](#) [IG17X1000S4I](#) [IG22X250S4I](#) [VTD205H](#) [VTD205KH](#)
[VTP1220FBH](#) [VTP1232FH](#) [VTP4085H](#) [SFH 2400](#) [OP913WSL](#) [OPF794](#) [PD70-01C/TR7](#) [LTR-536AD](#) [VTP8651H](#) [VTD206KH](#) [VTB1013H](#)
[BPV23NF](#) [OP905](#) [LTR-516AD](#) [BPW 34 FS-Z](#) [VTD34FH](#) [QSB34CGR](#) [SFH 2500 FA](#) [SFH 213 FA](#) [PD15-22C/TR8](#) [VEMD5510C](#) [SFH](#)
[2200](#) [VEMD5510CF](#) [APS5130PD7C-P22](#) [SAH230M](#) [SAH230M2](#) [SAH500M2](#) [BP 104 FS](#) [BPV22F-AS12](#) [BPW 21](#) [BPW 34 SR-Z](#) [BPX 65](#)