

Photologic® Optically Coupled Isolator



OPI125, OPI126, OPI128

Features:

- Multiple output options
- 15 kV dc input-to-output isolation voltage
- Direct TTL/STTL interface
- High noise immunity
- Data rates to 250 KBit/s
- Hermetically sealed
- TX-TXV process available
- UL File No. E 58730*

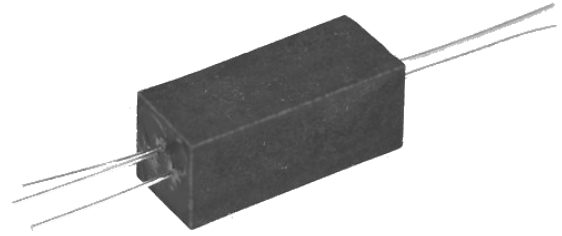

Description:

Each **OPI125**, **OPI126**, and **OPI128** consists of an optically coupled isolator with a gallium arsenide infrared emitting diode coupled to a monolithic integrated circuit. This circuit incorporates a photodiode, a linear amplifier and a Schmitt trigger on a single silicon chip. For maximum long-term stability, both the diode and the Photologic® sensor are hermetically sealed in separate packages and then mounted in a high dielectric plastic housing.

These devices feature TTL/LSTTL compatible logic level output that can drive up to 8 TTL loads directly without additional circuitry. Also featured are medium-speed data rates to 250 KBit/s, with typical rise and fall times of 70 nanoseconds. *UL recognition is for 15kV dc to 100° C.

TX and TXV processing is available. For more information, contact your local representative or OPTEK.

Applications:

- High voltage isolation between input and output
- Electrical isolation in dirty environments
- Industrial equipment
- Medical equipment
- Office equipment

Ordering Information								
Part Number	LED Peak Wavelength	Sensor Photologic®	Isolation Voltage (,000)	t _{PLH} / t _{PHL} Typ (µs)	I _F (mA) Typ / Max	V _{CE} (Volts) Max	Lead Length / Spacing	*Length
OPI125	890nm	Totem Pole	15	5 / 5	7.5 / 25	35.0	0.40" / 0.75"	0.75" [19mm]
OPI126	935nm	Open Collector						
OPI128	890nm	Inverted Open Collector						

Pin #	LED	Pin #	Photologic®
1	Anode	3	Output
2	Cathode	4	Vcc
		5	Ground

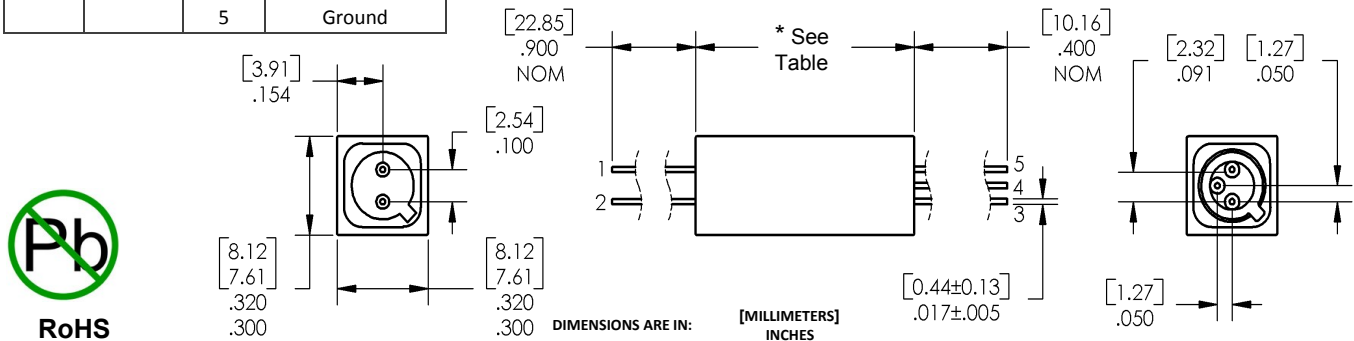

General Note

TT Electronics reserves the right to make changes in product specification without notice or liability. All information is subject to TT Electronics' own data and is considered accurate at time of going to print.

TT Electronics | OPTEK Technology, Inc.
1645 Wallace Drive, Carrollton, TX 75006 | Ph: +1 972 323 2200
sensors@ttelelectronics.com | www.ttelelectronics.com

Photologic® Optically Coupled Isolator



OPI125, OPI126, OPI128

OPI125 - Totem Pole Output

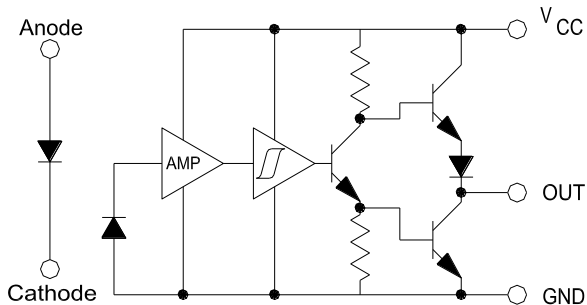

OPI126 - Open Collector Output

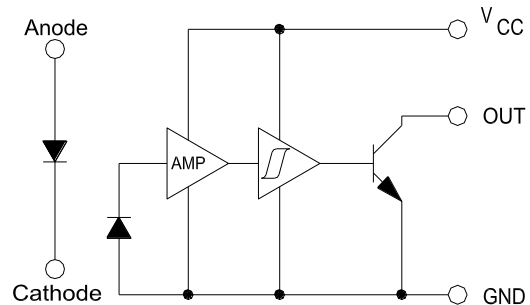

OPI128 - Inverted Open Collector Output

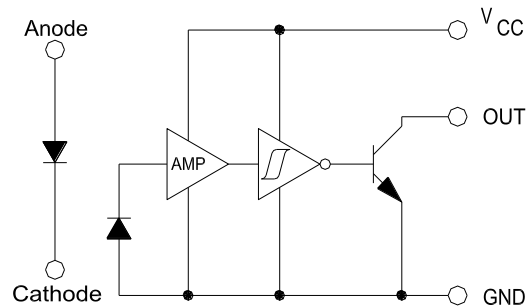

Absolute Maximum Ratings ($T_A = 25^\circ\text{C}$ unless otherwise noted)

Storage Temperature	-55° C to +100° C
Operating Temperature	-55° C to +100° C
Supply Voltage, V_{CC} (not to exceed 3 seconds)	+10 V
Input-to-Output Isolation Voltage ⁽¹⁾⁽²⁾	± 15 kVDC
Lead Soldering Temperature (1/16" (1.6 mm) from case for 5 seconds with soldering iron) ⁽³⁾	260° C
Input Diode	
Forward DC Current	25 mA
Reverse DC Voltage	2 V
Power Dissipation ⁽⁴⁾	200 mW
Output Photosensor	
Output Photologic® Power Dissipation ⁽⁵⁾	120 mW
Duration of Output Short to VCC or Ground (OPI125, OPI127)	1.00 second
Duration of Output Short to VCC (OPI126, OPI128)	1.00 second
Voltage at Output Lead (OPI126, OPI128)	35 V

Notes:

- (1) Measured with input and output leads shorted.
- (2) UL recognition is for 15kV dc for one minute
- (3) RMA flux is recommended. Duration can be extended to 10 seconds maximum when flow soldering.
- (4) Derate linearly 1.33 mW/° C above 25° C.
- (5) Derate linearly 3.40 mW/° C above 90° C.

General Note

TT Electronics reserves the right to make changes in product specification without notice or liability. All information is subject to TT Electronics' own data and is considered accurate at time of going to print.

TT Electronics | OPTEK Technology, Inc.
1645 Wallace Drive, Carrollton, TX 75006 | Ph: +1 972 323 2200
sensors@ttelelectronics.com | www.ttelelectronics.com

Photologic® Optically Coupled Isolator



OPI125, OPI126, OPI128

Electrical Characteristics (T_A = -40° C to +85° C unless otherwise noted)

SYMBOL	PARAMETER	MIN	TYP	MAX	UNITS	TEST CONDITIONS
Diode Input (See OP130 and OP230 for additional information - for reference only)						
V _F	Forward Voltage	-	-	1.5	V	I _F = 10 mA, T _A = 25° C
I _R	Reverse Current	-	-	100	μA	V _R = 2 V, T _A = 25° C
I _F (+)	LED Positive-Going threshold Current	-	-	7.5	mA	V _{CC} = 5 V, T _A = 25° C
I _F (+)/I _F (-)	Hysteresis Ratio	-	2.0	-	-	-
Photologic® Output (See OP800 and OP801 for additional information - for reference only)						
V _{CC}	Operating Supply Voltage	4.5	-	5.5	V	-
I _{CC}	Supply Current	-	-	20	mA	V _{CC} = 5.5 V, I _F = 0 or 7.5 mA
V _{OL}	Low Level Output Voltage OPI125 OPI126 OPI128	- - -	- - -	0.40 0.40 0.40	V	V _{CC} = 4.5 V, I _{OL} = 13 mA, I _F = 0 mA V _{CC} = 4.5 V, I _{OL} = 13 mA, I _F = 0 mA V _{CC} = 4.5 V, I _{OL} = 13 mA, I _F = 7.5 mA
V _{OH}	High Level Output Voltage OPI125	2.4 2.4	- -	- -	V	V _{CC} = 4.5 V, I _{OH} = -800 μA, I _F = 7.5 mA V _{CC} = 4.5 V, I _{OH} = -800 μA, I _F = 0 mA
I _{OS}	Short Circuit Output Current OPI125	-20	-	-120	mA	V _{CC} = 5.5 V, I _F = 7.5 mA, Output = GND
I _{OH}	High Level Output Current OPI126 OPI128	- -	- -	100 100	μA	V _{CC} = 4.5 V, V _{OH} = 30 V, I _F = 7.5 mA V _{CC} = 4.5 V, V _{OH} = 30 V, I _F = 0 mA
t _r , t _f	Output Rise Time, Output Fall Time OPI125	-	100	-	ns	V _{CC} = 5 V, T _A = 25° C, I _F = 0 or 10 mA, f = 10 kHz, D.C. = 50%, R _L = 8 TTL loads
	Output Rise Time, Output Fall Time OPI126, OPI128	-	100	-		V _{CC} = 5 V, T _A = 25° C, I _F = 0 or 10 mA, f = 10 kHz, D.C. = 50%, R _L = 360 Ω
t _{PLH} , t _{PHL}	Propagation Delay, Low-High, High-Low OPI125	-	5	-	μs	V _{CC} = 5 V, T _A = 25° C, I _F = 0 or 10 mA, f = 10 kHz, D.C. = 50%, R _L = 8 TTL loads
	Propagation Delay, Low-High, High-Low OPI126, OPI128	-	5	-		V _{CC} = 5 V, T _A = 25° C, I _F = 0 or 10 mA, f = 10 kHz, D.C. = 50%, R _L = 360 Ω

General Note

TT Electronics reserves the right to make changes in product specification without notice or liability. All information is subject to TT Electronics' own data and is considered accurate at time of going to print.

TT Electronics | OPTEK Technology, Inc.
1645 Wallace Drive, Carrollton, TX 75006 | Ph: +1 972 323 2200
sensors@ttelelectronics.com | www.ttelelectronics.com

X-ON Electronics

Largest Supplier of Electrical and Electronic Components

Click to view similar products for [High Speed Optocouplers](#) category:

Click to view products by [TT Electronics](#) manufacturer:

Other Similar products are found below :

[HCPL-2201-300](#) [TLP558\(F\)](#) [JAN4N24](#) [610737H](#) [HCPL2630M](#) [HCPL2731SM](#) [HCPL2630SM](#) [PS9817A-1-F3-AX](#) [TLP2766A\(E\)](#)
[EL816S2\(C\)\(TU\)-F](#) [TLP281-4](#) [PS9121-F3-AX](#) [PS9123-F3-AX](#) [HCPL2531S](#) [HCPL2631SD](#) [HCPL-4661-500E](#) [TLP118\(TPL,E\)](#) [TLP521-](#)
[2XGB](#) [TLP621-2XGB](#) [4N46-300E](#) [JANTXV4N24U](#) [SFH6318T](#) [6N135-300E](#) [TIL198](#) [TLP2309\(TPL,E\)](#) [TLP2355\(TPL,E\)](#) [TLP521-4GR](#)
[TLP521-4XGB](#) [TLP621-4X](#) [TLP621XSM](#) [IS281-4GB](#) [IS181GR](#) [ICPL2631](#) [ICPL2630](#) [ICPL2601](#) [TLP714\(F\)](#) [TLP754\(F\)](#) [FOD260LSDV](#)
[ACPL-M21L-500E](#) [ACPL-064L-500E](#) [PS2501-1XSM](#) [PS2505-1](#) [PS2561L2-1-F3-A](#) [PS2913-1-F3-AX](#) [PS9821-2-F3-AX](#) [FOD0721R2](#)
[FODM8061R2V](#) [6N135SDM](#) [6N137SDM](#) [6N138-000E](#)