

Photologic® Sensor

OPL530, OPL531, OPL535, OPL536, OPL550,
OPL551, OPL560, OPL561, OPL562, OPL563



Features:

- Choice of four output options in low-cost side-looking package
- Choice of two sensitivity options (OPL560/561/562/563)
- High noise immunity
- Direct TTL/LSTTL CMOS interface
- Data rates to 250 kBaud for all except OPL560 series (200 kBaud)
- Low power consumption

Description:

All components in this series include a photodiode, amplifier, voltage regulator, Schmitt trigger and NPN output transistor on a single silicon chip. **OPL560** chips also include a voltage regulator on the chip. All devices in the series have a Photologic® chip that is encapsulated in a molded plastic side-looking package with an integral lens (recessed integral lens for OPL535 and OPL536). This packaging provides enhanced optical coupling, combined with mechanical protection. The hysteresis characteristics of the Schmitt trigger on each device offers high immunity to noise on input and V_{CC} .

OPL530, OPL531, OPL535 and **OPL536** include a 10 K Ω pull-up resistor (R_L) from output to V_{CC} . These components exhibit very stable performance over supply voltages ranging from 4.5 V to 16 V and a wide range of irradiance levels. **OPL550** and **OPL551** devices feature TTL/LSTTL compatible logic level output which can drive up to 8 TTL loads without additional circuitry and medium-speed data rates to 250 kBaud, with typical rise and fall times of 25 nanoseconds. **OPL560, OPL561, OPL562** and **OPL563** devices feature TTL/LSTTL compatible logic level output which can drive up to 10 TTL loads over supply voltages ranging from 4.5 V to 16 V.

OPL530, OPL531, OPL550, OPL551, OPL560, OPL561, OPL562 and **OPL563** are mechanically and spectrally matched to OP140 and OP240 LEDs. **OPL535** and **OPL536** are mechanically and spectrally matched to OP145 and OP245 series LEDs.

Applications:

- Non-contact reflective object sensor
- Assembly line automation
- Machine automation
- Machine safety
- End of travel sensor
- Door sensor

Base Part Number	Package	Output Type - with Light	Input Power Range (mW/cm ²) [Min/Max]		
			-	A	B
OPL530, OPL530-OC	External Lens	Internal 10K - High	0.08/0.40	0.08/0.25	0.20/0.40
OPL531A, OPL531-OCA		Internal 10K - Low			
OPL535A, OPL535B	Recessed Lens	Internal 10K - High			
OPL536A, OPL536-OC, OPL536-OCA		Internal 10K - Low			
OPL550, OPL550A, OPL550-OC, OPL550-OCA	External Lens	Totem Pole - High	0.25/2.4	0.25/1.4	N/A
OPL551A, OPL551-OC, OPL551-OCA		Totem Pole - Low	0.25/2.5	0.25/1.5	
OPL560, OPL560A, OPL560-OCA		Totem Pole - High	0.09/0.55	0.09/0.36	N/A
OPL561, OPL561-OC, OPL561-OCA		Totem Pole - Low			
OPL562, OPL562A, OPL562-OC, OPL562-OCA		Totem Pole - High	0.025/0.23	0.025/0.14	N/A
OPL563, OPL563-OC, OPL563-OCA		Totem Pole - Low			

OC = Open Collector Output

General Note

TT Electronics reserves the right to make changes in product specification without notice or liability. All information is subject to TT Electronics' own data and is considered accurate at time of going to print.

TT Electronics | OPTEK Technology
1645 Wallace Drive, Carrollton, TX 75006 | Ph: +1 972 323 2200
www.ttelectronics.com | sensors@ttelectronics.com

OPL530, OPL550, OPL560 Series

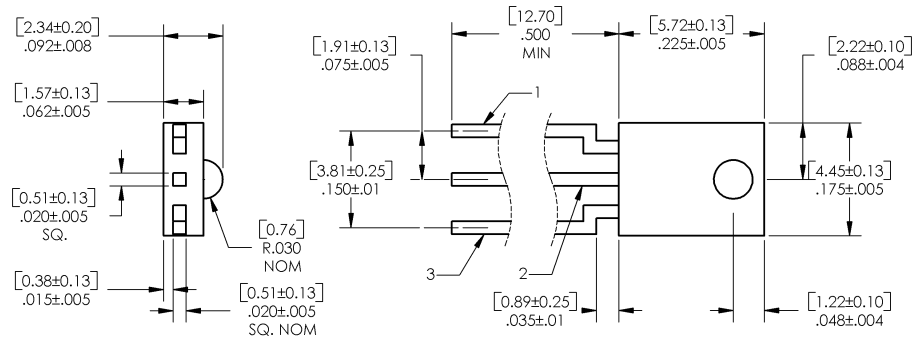

DIMENSIONS ARE IN: [MILLIMETERS]
INCHES

Pin #	Sensor
1	Ground
2	Output
3	V _{CC}

OPL535, OPL536 Series

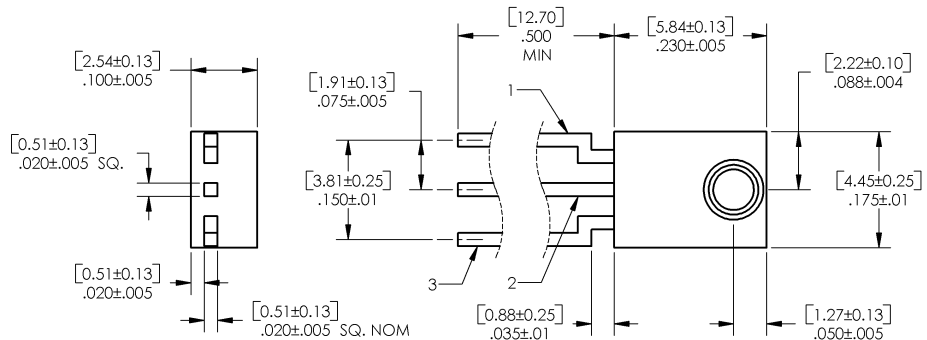

DIMENSIONS ARE IN: [MILLIMETERS]
INCHES

Pin #	Sensor
1	Ground
2	Output
3	V _{CC}

General Note

TT Electronics reserves the right to make changes in product specification without notice or liability. All information is subject to TT Electronics' own data and is considered accurate at time of going to print.

TT Electronics | OPTEK Technology
1645 Wallace Drive, Carrollton, TX 75006 | Ph: +1 972 323 2200
www.ttelectronics.com | sensors@ttelectronics.com

OPL530, OPL531, OPL535, OPL536, OPL550, OPL551, OPL560, OPL561, OPL562, OPL563 (-OC, -OCA, -OCB)
OPL550, OPL550A, OPL551A,
OPL560, OPL560A, OPL561, OPL562, OPL562A, OPL563, OPL563A

OPL550/550A/560/560A/562/562A Totem-Pole

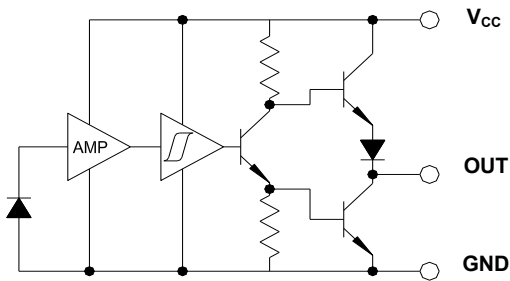

OPL530/535/550/560/562 (-OC, -OCA, -OCB) Open-Collector

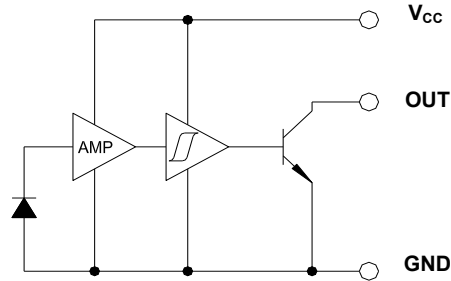

OPL 551A/561/563/563A Inverted Totem-Pole

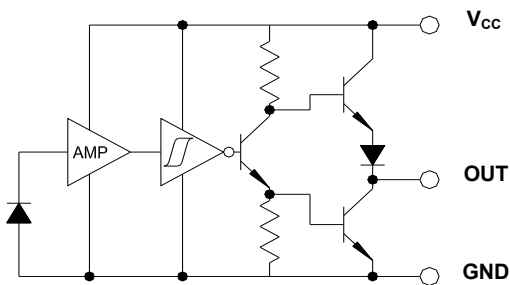

OPL 531/536/551/561/563 (-OC, -OCA, -OCB) Inverted Open-Collector

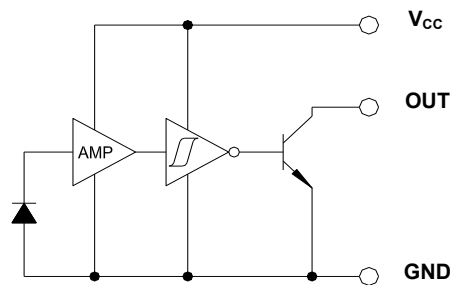

General Note

TT Electronics reserves the right to make changes in product specification without notice or liability. All information is subject to TT Electronics' own data and is considered accurate at time of going to print.

**OPL530, OPL531A,
OPL535A, OPL535B, OPL536, OPL536A**

OPL530, OPL535A/535B 10K Pull-Up

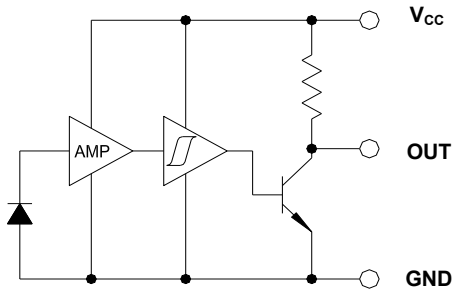

OPL531A OPL536A Inverted 10K Pull-Up

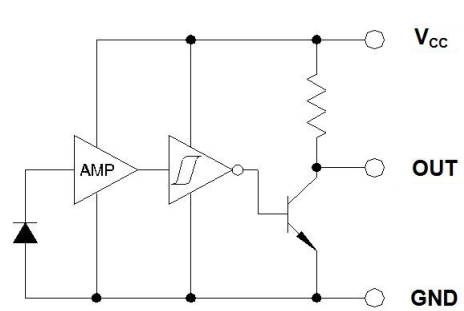

General Note

TT Electronics reserves the right to make changes in product specification without notice or liability. All information is subject to TT Electronics' own data and is considered accurate at time of going to print.

Absolute Maximum Ratings (T _A = 25° C unless otherwise noted)	
Input Diode	
Supply Voltage (V _{CC}) OPL530, OPL530-OC, OPL536-OC, OPL550 OPL560, OPL561, OPL562, OPL563	18 V 10 V 18 V
Operating Temperature Range	-40° C to + 85° C
Storage Temperature Range	-40° C to + 100° C
Lead Soldering Temperature [1/16 inch (1.6mm) from the case for 5 sec. with soldering iron]	260°C
Sourcing Current OPL560, OPL561, OPL562, OPL563	10 mA
Power Dissipation OPL530, OPL530-OC, OPL536-OC OPL550, OPL560, OPL561, OPL562, OPL563	90 mW 200 mW ⁽²⁾
Sinking Current OPL530, OPL530-OC, OPL536-OC OPL550 OPL560, OPL561, OPL562, OPL563	50 mA - 50 mA
Voltage at Output Lead ⁽⁴⁾ OPL530, OPL530-OC, OPL536-OC OPL550-OC, OPL551-OC OPL561-OC, OPL562-OC, OPL563-OC	35 V 35 V 35 V
Duration of Output Short to V _{CC} or Ground OP550	1 second
Duration of Output Short to V _{CC} OPL550-OC, OPL551-OC OPL560, OPL561, OPL562, OPL563, OPL561-OC, OPL562-OC, OPL563-OC	1 second 1 second
Low Level Output Current OPL550, OPL551 Series	16 mA
High Level Output Current OPL550, OPL551 Series	1 mA
Irradiance OPL550, OPL551 Series OPL560, OPL561, OPL561-OC OPL562, OPL562-OC, OPL563, OPL563-OC	10 mW/cm ² 9 mW/cm ² 3 mW/cm ²

Notes:

- (1) RMA flux is recommended. Duration can be extended to 10 sec. max. when flow soldering. For OPL530, OPL530-OC, OPL531, OPL531-OC, OPL535, OPL535-OC, OPL536 and OPL536-OC, a maximum of 20 grams force may be applied to leads while at soldering temperatures.
- (2) Derate linearly 2.67 mW/°C above 70° C for OPL530, OPL530-OC, OPL531, OPL531-OC, OPL535, OPL535-OC, OPL536 and OPL536-OC. Derate linearly 2.5 mW/° C above 25° C for all devices in the OPL550, OPL551, OPL560, OPL561, OPL562 and OPL563 series.
- (3) Irradiance measurements are made with λ_i = 935 nm.
- (4) This applies to OC versions only. For I_{CC} on pull-up versions, add V_{CC}/10 KΩ.

General Note

TT Electronics reserves the right to make changes in product specification without notice or liability. All information is subject to TT Electronics' own data and is considered accurate at time of going to print.

TT Electronics | OPTEK Technology
1645 Wallace Drive, Carrollton, TX 75006 | Ph: +1 972 323 2200
www.ttelectronics.com | sensors@ttelectronics.com

Electrical Characteristics (T _A = 25° C unless otherwise noted)						
SYMBOL	PARAMETER	MIN	TYP	MAX	UNITS	TEST CONDITIONS
V _{CC}	Operating Supply Voltage OPL530, OPL530-OC, OPL531, OPL531-OC OPL535, OPL535-OC, OPL536, OPL536-OC, OPL560, OPL561 Series	4.5	-	16	V	-
	OPL550, OPL551 Series	4.5	-	5.5	V	-
	Peak-to-Peak V _{CC} Ripple Necessary to Cause False Triggering of Output OPL530, OPL530-OC, OPL531, OPL531-OC OPL535, OPL535-OC, OPL536, OPL536-OC OPL560, OPL561 Series	-	-	2	V	f = DC to 50 MHz
	OPL550, OPL551 Series	-	2	-	V	V _{CC} = 5 V DC, f = DC to 50 MHz
I _{CC}	Supply Current ⁽⁴⁾ OPL530, OPL530-OC OPL536-OC	-	5	8	mA	E _E = 0 or 1 mW/cm ²
	OPL550, OPL551 Series	-	8	15	mA	E _E = 0 or 3 mW/cm ² , V _{CC} = 5.5 V
	OPL560, OPL561 Series	-	8	12	mA	E _E = 0 or 1 mW/cm ²
E _{E(+)}	Positive-Going Threshold Irradiance ⁽³⁾ OPL530, OPL530-OC OPL536-OC	0.08	-	0.40	mW/cm ²	T _A = 25° C
	OPL531A, OPL531-OCA OPL535A, OPL536A, OPL536-OCA	0.08	-	0.25	mW/cm ²	T _A = 25° C
	OPL535B	0.12	-	0.40	mW/cm ²	T _A = 25° C
	OPL550, OPL550-OC, OPL551-OC OPL550A, OPL550-OCA, OPL551-OCA	.25 .25	- -	2.4 1.4	mW/cm ² mW/cm ²	V _{CC} = 5 V, T _A = 25° C V _{CC} = 5 V, T _A = 25° C

General Note

TT Electronics reserves the right to make changes in product specification without notice or liability. All information is subject to TT Electronics' own data and is considered accurate at time of going to print.

TT Electronics | OPTEK Technology
1645 Wallace Drive, Carrollton, TX 75006 | Ph: +1 972 323 2200
www.ttelectronics.com | sensors@ttelectronics.com

Electrical Characteristics (T _A = 25° C unless otherwise noted)						
SYMBOL	PARAMETER	MIN	TYP	MAX	UNITS	TEST CONDITIONS
E _{et(+)} /E _{et(-)}	Hysteresis Ratio OP530, OP531 Series	1.05	1.3	1.6	-	-
	OP535, OP536 Series	1.05	1.2	1.5	-	-
	OPL550, OPL551 Series	1.05	2	2.5	-	-
	OPL560, OPL561 Series	1.20	1.55	2	-	-
ΔE _{et(+)} (ΔT)	Temperature Co-efficient OPL530, OPL530-OC	-	-0.6	-	%/°C	>0°C
	OPL536-OC	-	-1.6	-	%/°C	<0°C

Notes:

- (1) RMA flux is recommended. Duration can be extended to 10 sec. max. when flow soldering. For OPL530, OPL530-OC, and OPL536-OC, a maximum of 20 grams force may be applied to leads while at soldering temperatures.
- (2) Derate linearly 2.67 mW/°C above 70° C for OPL530, OPL530-OC, and OPL536-OC. Derate linearly 2.5 mW/° C above 25° C for all devices in the OPL550, OPL560, OPL561, OPL562 and OPL563 series.
- (3) Irradiance measurements are made with λ_i = 935 nm.
- (4) This applies to OC versions only. For I_{cc} on pull-up versions, add V_{cc}/10 KΩ.

General Note

TT Electronics reserves the right to make changes in product specification without notice or liability. All information is subject to TT Electronics' own data and is considered accurate at time of going to print.

Electrical Characteristics (T _A = 25° C unless otherwise noted)						
SYMBOL	PARAMETER	MIN	TYP	MAX	UNITS	TEST CONDITIONS
V _{OH}	Operating Supply Voltage OPL550	2.4	3.3	-	V	V _{CC} = 4.5 V, I _{OH} = -800 µA, E _E = 3 mW/cm ²
	OPL560	V _{CC} - 2.1	-	-	V	I _{OH} = -1 µA, E _E = 1 mW/cm ²
	OPL561	V _{CC} - 2.1	-	-	V	I _{OH} = -1 µA, E _E = 0
V _{OL}	Low Level Output Voltage OPL530, OPL530-OC	-	0.2	0.4	V	I _{OL} = 16 mA, E _E = 0
	OPL536-OC	-	0.2	0.4	V	I _{OL} = 16 mA, E _E = 1 mW/cm ²
	OPL550	-	0.25	0.4	V	V _{CC} = 4.5 V, I _{OL} = 12.8 mA, E _E = 0
	OPL560	-	-	0.4	V	I _{OL} = 16 mA, E _E = 0
	OPL561, OPL561-OC	-	-	0.4	V	I _{OL} = 16 mA, E _E = 1 mW/cm ²
I _{OS}	Short Circuit Output Current OPL550	-20	-55	-100	mA	V _{CC} = 5.5 V, Output = GND, E _E = 3 mW/cm ²
I _{OH}	High Level Output Current ⁽⁴⁾ OPL536-OC	-	0.1	10	µA	V _{OH} = 30 V, E _E = 0
	OPL530, OPL530-OC	-	0.1	10	µA	V _{OH} = 30 V, E _E = 1 mW/cm ²
	OPL550-OC	-	1	100	µA	V _{CC} = 4.5 V, V _{OH} = 30 V, E _E = 3 mW/cm ²
	OPL551-OC	-	1	100	µA	V _{CC} = 4.5 V, V _{OH} = 30 V, E _E = 0
	OPL561-OC	-	-	100	µA	V _{OH} = 30 V, E _E = 0

Notes:

- (1) RMA flux is recommended. Duration can be extended to 10 sec. max. when flow soldering. For OPL530, OPL530-OC, and OPL536-OC, a maximum of 20 grams force may be applied to leads while at soldering temperatures.
- (2) Derate linearly 2.67 mW/°C above 70° C for OPL530, OPL530-OC, and OPL536-OC. Derate linearly 2.5 mW/° C above 25° C for all devices in the OPL550, OPL560, OPL561, OPL562 and OPL563 series.
- (3) Irradiance measurements are made with λ_i = 935 nm.
- (4) This applies to OC versions only. For I_{CC} on pull-up versions, add V_{CC}/10 KΩ.

General Note

TT Electronics reserves the right to make changes in product specification without notice or liability. All information is subject to TT Electronics' own data and is considered accurate at time of going to print.

Electrical Characteristics (T _A = 25° C unless otherwise noted)						
SYMBOL	PARAMETER	MIN	TYP	MAX	UNITS	TEST CONDITIONS
t _r	Output Rise Time OPL530	-	1500	-	ns	E _E = 0 or 1 mW/cm ² , C _L = 50 pF, 10K P.U.
	OPL530-OC, OPL536-OC	-	50	-	ns	E _E = 0 or 1 mW/cm ² , R _L = 300 Ω to 5 V, C _L = 50 pF
	OPL550	-	25	70	ns	V _{CC} = 5 V, T _A = 25° C, E _E = 0 or 3 mW/cm ² , f = 10 kHz, DC = 50% R _L = 8 TTL loads
	OPL550-OC, OPL551-OC	-	25	70	ns	V _{CC} = 5 V, T _A = 25° C, E _E = 0 or 3 mW/cm ² , f = 10 kHz, DC = 50%, R _L = 360 Ω
	OPL560, OPL561 OPL561-OC	- -	- -	70 100	ns ns	T _A = 25° C, E _E = 0 or 1 mW/cm ² , f = 10 kHz, DC = 50%, R _L = 360 Ω
t _r	Output Rise Time OPL530	-	-	-	ns	E _E = 0 or 1 mW/cm ² , C _L = 50 pF
	OPL530-OC, OPL536-OC	-	-	-	ns	E _E = 0 or 1 mW/cm ² , R _L = 300 Ω to 5 V, C _L = 50 pF
	OPL550-OC, OPL551-OC	-	25	70	ns	V _{CC} = 5 V, T _A = 25° C, E _E = 0 or 3 mW/cm ² , R _L = 8 TTL loads, f = 10 kHz, DC = 50%
	OPL561-OC	-	-	70	ns	V _{CC} = 5 V, T _A = 25° C, E _E = 0 or 3 mW/cm ² , R _L = 8 TTL loads, f = 10 kHz, DC = 50%
	OPL560, OPL561 OPL561-OC	- -	- -	70 100	ns ns	T _A = 25° C, E _E = 0 or 1 mW/cm ² , f = 10 kHz T _A = 25° C, E _E = 0 or 1 mW/cm ² , f = 10 kHz
t _f	Output Fall Time OPL530	-	20	-	ns	E _E = 0 or 1 mW/cm ² , C _L = 50 pF
	OPL530-OC, OPL536-OC	-	20	-	ns	E _E = 0 or 1 mW/cm ² , R _L = 300 Ω to 5 V, C _L = 50 pF
	OPL550-OC, OPL551-OC	-	25	70	ns	V _{CC} = 5 V, T _A = 25° C, E _E = 0 or 3 mW/cm ² , R _L = 360 Ω, f = 10 kHz, DC = 50%
	OPL560, OPL561	-	-	70	ns	T _A = 25° C, E _E = 0 or 1 mW/cm ² , f = 10 kHz
	OPL561-OC	-	-	100	ns	T _A = 25° C, E _E = 0 or 1 mW/cm ² , f = 10 kHz

Notes:

- (1) RMA flux is recommended. Duration can be extended to 10 sec. max. when flow soldering. For OPL530, OPL530-OC, and OPL536-OC, a maximum of 20 grams force may be applied to leads while at soldering temperatures.
- (2) Derate linearly 2.67 mW/°C above 70° C for OPL530, OPL530-OC and OPL536-OC. Derate linearly 2.5 mW/° C above 25° C for all devices in the OPL550, OPL560, OPL561, OPL562 and OPL563 series.
- (3) Irradiance measurements are made with λ_i = 935 nm.
- (4) This applies to OC versions only. For I_{CC} on pull-up versions, add V_{CC}/10 KΩ.

General Note

TT Electronics reserves the right to make changes in product specification without notice or liability. All information is subject to TT Electronics' own data and is considered accurate at time of going to print.

Electrical Characteristics (T_A = 25° C unless otherwise noted)

SYMBOL	PARAMETER	MIN	TYP	MAX	UNITS	TEST CONDITIONS
tpE _{et} (+)	Propagation Delay OPL530	-	1.0	-	μs	E _E = 0 or 1 mW/cm ² , R _L = 300 Ω to 5 V, C _L = 50 pF
	OPL530-OC, OPL536-OC	-	1.0	-	μs	E _E = 0 or 1 mW/cm ² , R _L = 300 Ω to 5 V, C _L = 50 pF
	OPL550-OC, OPL551-OC	-	2.5	5	μs	V _{CC} = 5 V, T _A = 25° C, E _E = 0 or 3 mW/cm ² , R _L = 8 TTL loads, f = 10 kHz, DC = 50%
tpE _{et} (-)	Propagation Delay OPL530, OPL530-OC, OPL536-OC	-	3.0	-	μs	E _E = 0 or 1 mW/cm ² , R _L = 300 Ω to 5V, C _L = 50 pF
	OPL550-OC, OPL551-OC	-	2.5	5	μs	V _{CC} = 5 V, T _A = 25° C, E _E = 0 or 3 mW/cm ² , R _L = 360 Ω, f = 10 kHz, DC = 50%
t _{PLH} , T _{PHL}	Propagation Delay (Low-High/High-Low) OPL560, OPL561	-	5	-	μs	DC = 50%, R _L = 10 TTL Loads
	OPL561-OC	-	5	-	μs	DC = 50%, R _L = 300 Ω

Notes:

- (1) RMA flux is recommended. Duration can be extended to 10 sec. max. when flow soldering. For OPL530, OPL530-OC, OPL536, a maximum of 20 grams force may be applied to leads while at soldering temperatures.
- (2) Derate linearly 2.67 mW/°C above 70° C for OPL530, OPL530-OC, OPL531, OPL531-OC, OPL535, OPL535-OC, OPL536 and OPL536-OC. Derate linearly 2.5 mW/°C above 25° C for all devices in the OPL550, OPL551, OPL560, OPL561, OPL562 and OPL563 series.
- (3) Irradiance measurements are made with λ_i = 935 nm.
- (4) This applies to OC versions only. For I_{CC} on pull-up versions, add V_{CC}/10 KΩ.

General Note

TT Electronics reserves the right to make changes in product specification without notice or liability. All information is subject to TT Electronics' own data and is considered accurate at time of going to print.

TT Electronics | OPTEK Technology
1645 Wallace Drive, Carrollton, TX 75006 | Ph: +1 972 323 2200
www.ttelectronics.com | sensors@ttelectronics.com

X-ON Electronics

Largest Supplier of Electrical and Electronic Components

Click to view similar products for [Photo IC Sensors](#) category:

Click to view products by [TT Electronics](#) manufacturer:

Other Similar products are found below :

[OPL800](#) [OPL810](#) [OPL811-OC](#) [OPL820](#) [ADPD2210ACPZ-R7](#) [OPL801](#) [OPL813-OC](#) [OPL820-OC](#) [ADPD2214ACPZ-R7](#) [HOA6299-003](#)
[SD5610-001](#) [SD5630-001](#) [SD5630-002](#) [SDP8600-003](#) [SDP8601-002](#) [SDP8610-003](#) [SDP8611-002](#) [SDP8611-003](#) [QSE159](#) [QSE259](#)
[BU27006MUC-ZTR](#) [OPL821](#) [OPL530-OC](#) [OPL531-OCA](#) [OPL550-OCA](#) [OPL562](#) [OPL562-OC](#) [OPL563-OC](#) [OP538F-001](#) [OP600-012](#)
[VEML3328SL](#) [VEML6040A3OG](#) [OPL801-OC](#) [OPL560](#) [SDP8614-301](#) [LTDL-TA16A](#) [OPL551](#)