

Heatsink for WMHP Series High Power Resistors

WMHP-HS Series

- For TO-220 and TO-247 packages
- Ideal for use with WMHP series power resistors
- Ridged fins for higher surface area with low mass
- Low thermal resistance
- Black anodised finish
- Solderable pins for robust PCB mounting

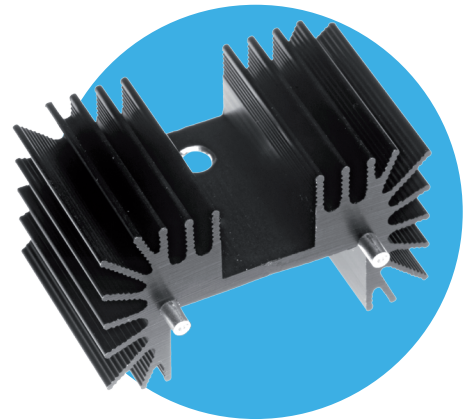

All parts are Pb-free and comply with EU Directive 2011/65/EU (RoHS2)

Functional Data

		WMHP-HS-25
Height	mm	25.4
Compatible package type		TO-220, TO-247
Compatible resistors		WMHP20, WMHP35, WMHP50, WMHP100
Surface area	mm ²	10,155
Weight	g	22.7
Thermal resistance, forced air 5m/s	°C/W	0.5

Physical Data

Dimensions (mm)			
Type	H nom		
WMHP-HS-25	25.4		

Construction

The heatsink is extruded from 6063-T5 aluminium cut to length, drilled and then black anodised. Two 2.3mm diameter brass pins with 100% tin finish are interference fitted.

General Note

TT Electronics reserves the right to make changes in product specification without notice or liability. All information is subject to TT Electronics' own data and is considered accurate at time of going to print.

Thermal Performance - Data

Forced Air Cooling - Standard Test

Thermal Resistance from Mounting Surface to Ambient

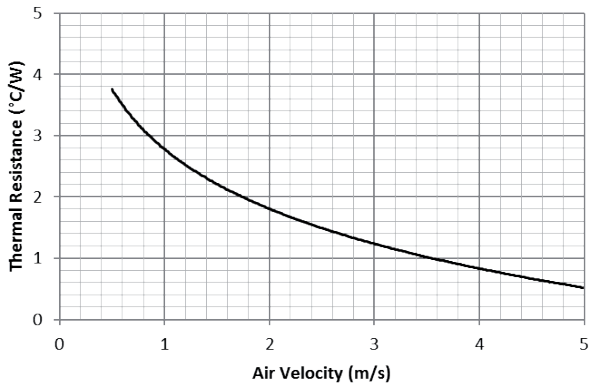

Forced Air Cooling - PCB Mounted

Thermal Resistance from Mounting Surface to Ambient

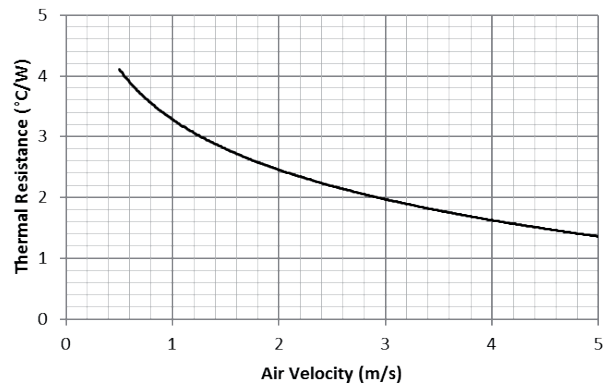

Natural Convection - Standard Test

Temperature Rise of Mounting Surface above Ambient

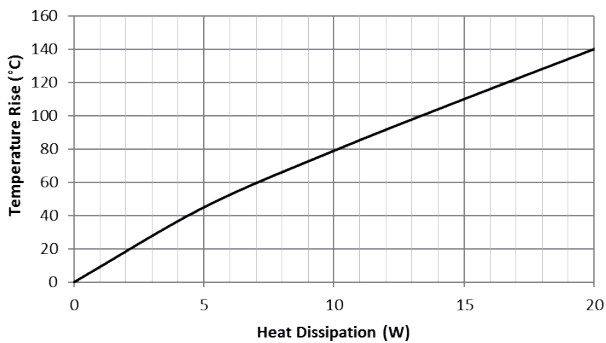

Natural Convection - PCB Mounted

Temperature Rise of Mounting Surface above Ambient

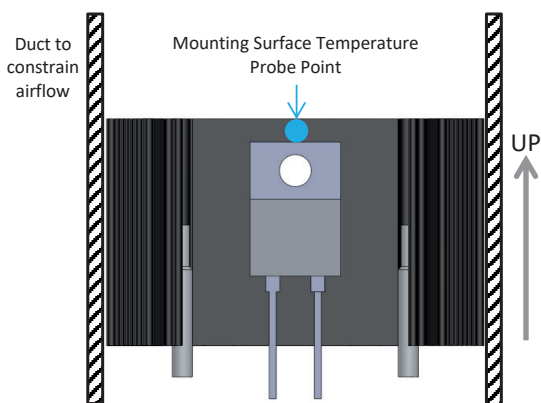
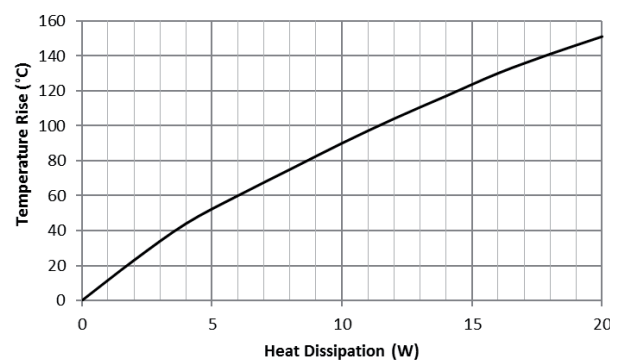

These data relate to a standard heatsink test condition with unobstructed fins and ducted airflow, and are included for comparison purposes.

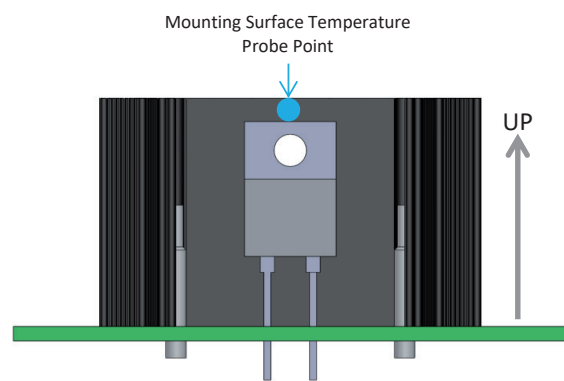

These data relate to a normal application condition with fins obstructed by a PCB and non-ducted airflow, and may be used for practical thermal design.

General Note

TT Electronics reserves the right to make changes in product specification without notice or liability. All information is subject to TT Electronics' own data and is considered accurate at time of going to print.

Application Notes

Steady State Thermal Calculations

A simple thermal model of a power resistor on a heatsink is shown, in which temperature rise may be calculated from the product of power dissipated and thermal impedance. Maximum P , T_E and $R_{\theta EF}$ values for WMHP are given below.

Type	P Max @ $T_F = 25^\circ\text{C}$ (W)	T_E Max ($^\circ\text{C}$)	$R_{\theta EF}$ ($^\circ\text{C}/\text{W}$)
WMHP20	20	150	6.25
WMHP35	35		3.57
WMHP50	50		2.50
WMHP100	100		1.50

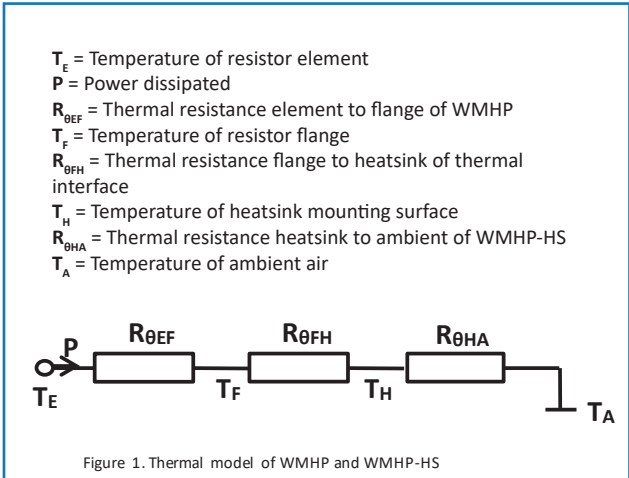

The maximum value of P for $T_F > 25^\circ\text{C}$ is a function of T_F and is shown in the WMHP datasheet de-rating graph. The value of $R_{\theta FH}$ depends on the thermal interface material. For thermal paste a typical figure is around $1^\circ\text{C}/\text{W}$. For forced air cooling the value of $R_{\theta HA}$ is shown as a function of air velocity in the Forced Air Cooling graph. For natural convection $R_{\theta HA}$ is slightly non-linear, as shown in the Natural Convection graph. The standard figure at $P = 20\text{W}$ is given, and for lower powers you can directly read the heatsink temperature rise $T_H - T_A$.

Example: WMHP20 is dissipating 5W at an ambient air temperature of 30°C . The WMHP-HS is PCB mounted and cooled by natural convection. Is the maximum resistor element temperature acceptable? $T_A = 30^\circ\text{C}$, and $T_H - T_A = 50^\circ\text{C}$ at $P = 5\text{W}$. Therefore $T_H = 80^\circ\text{C}$. Assuming $R_{\theta FH} = 1^\circ\text{C}/\text{W}$, $T_F = 85^\circ\text{C}$. Therefore $T_E = 85^\circ\text{C} + 6.25^\circ\text{C}/\text{W} \times 5\text{W} = 116^\circ\text{C}$. This is acceptable as it is below 150°C .

Dynamic Thermal Calculations

In some applications such as inrush current control, the dissipation of power is of limited duration. If the duration is between about 30s and 10 minutes then the dynamic temperature rise graph may be used to determine the highest value of T_H achieved at the end of the loading. The derivation of T_F and T_E is then the same as for the steady state case.

If power is reapplied before the heatsink has fully cooled, then cumulative heating must be accounted for. This can generally be ignored if the mean power dissipation is below 10% of the maximum permissible steady state dissipation.

For durations below about 30s, the best guide is the Pulse Performance graph on the WMHP datasheet.

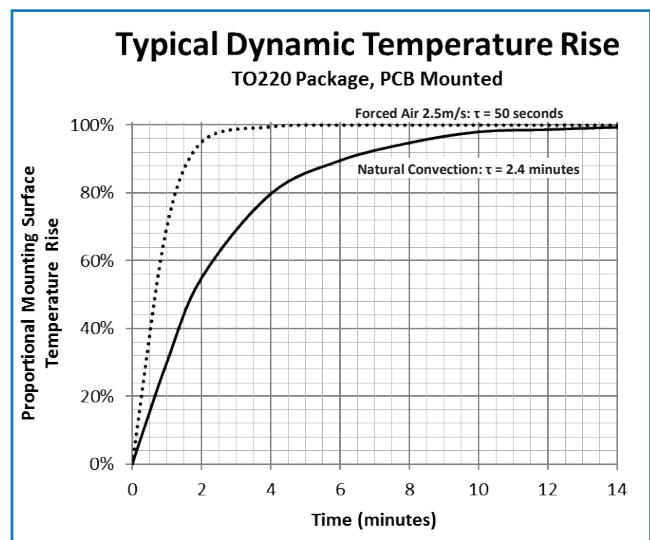

General Note

TT Electronics reserves the right to make changes in product specification without notice or liability. All information is subject to TT Electronics' own data and is considered accurate at time of going to print.

Heatsink for WMHP Series High Power Resistors

WMHP-HS Series

Layout Design and Assembly

A TO-220 package may be fitted to either side of the heatsink; thermal performance is the same for both mounting surfaces. Furthermore, two packages may be fitted, one to each side, provided the total power dissipated does not exceed the rating of either. A TO-247 package can only be fitted to the wider of the two mounting surfaces.

If other heat generating components are present nearby, the heatsink orientation should be chosen so that the side with more fins is located away from the heat source.

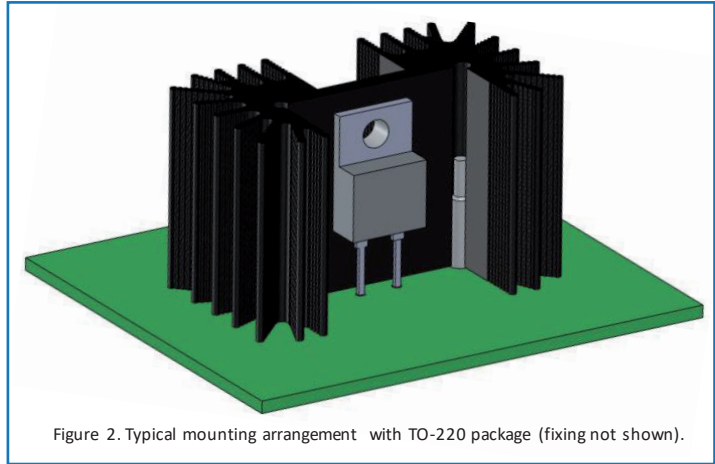

Figure 2. Typical mounting arrangement with TO-220 package (fixing not shown).

The package should be fitted to the heatsink using a suitable thermal interface material, for example a thermal pad or paste such as Dow Corning DC340. It should be secured with an M3 mounting screw tightened to give void-free thermal contact and to a maximum torque of 0.9Nm.

The pins are intended for soldering to traces on the reverse side of the PCB. Care should be taken to provide sufficient heat to achieve these solder joints.

A 3-D drawing of this heatsink may be downloaded from http://www.ttelectronics.com/themes/ttelectronics/downloads/resistors/3d_drawings/WMHP-HS.zip

This product is designed for use with WMHP series power resistors, but is suitable for any components in the same or similar package style. For WMHP product data see <http://www.ttelectronics.com/sites/default/files/resistors-datasheets/WMHP.pdf>

Ordering Procedure

Example: WMHP-HS-25AB005 (WMHP-HS, 25.4mm high, black anodized, Pb-free)

W	M	H	P	-	H	S	-	2	5	A	B	0	0	5
1							2	3	4					

1	2	3	5		
Series	Height	Finish	Packing		
WMHP-HS	25 = 25.4mm	A = Black anodised	B005	WMHP-HS-25	Bulk 50/box

General Note

TT Electronics reserves the right to make changes in product specification without notice or liability. All information is subject to TT Electronics' own data and is considered accurate at time of going to print.

X-ON Electronics

Largest Supplier of Electrical and Electronic Components

Click to view similar products for [Heat Sinks](#) category:

Click to view products by [TT Electronics](#) manufacturer:

Other Similar products are found below :

[581102B00000G](#) [656-15ABPE](#) [657-20ABPNE](#) [7020B-TC12-MTG](#) [73452PPBA](#) [7G0011A](#) [PF720G](#) [A22-4026](#) [HAH10L](#) [HAH15L](#) [HF20](#)
[1542616-1](#) [HS-2506-F1](#) [HS-87M0-F2](#) [218-40CTE3](#) [231-69PAB-15V](#) [25-7520](#) [SW50-4G](#) [231-75PAB-13V](#) [231-75PAB-15V](#) [253-122ABE-](#)
[22](#) [PSC22CB](#) [CLP212SG](#) [CLP-7701G](#) [HAA083](#) [HAF10L](#) [HAQ10T](#) [D10100-28](#) [TO5-002D](#) [BDN183CBA01](#) [3-21053-4](#) [32438](#) [TX0506-1B](#)
[TX1806B](#) [LAE66A3CB](#) [WA-DT2-101E](#) [511-3U](#) [73381PPBA](#) [73403PPBA](#) [7G0047C](#) [COMX-440-HSP](#) [510-12M](#) [D10650-40T5](#) [V8511 Y](#)
[APF40-40-13CB/A01](#) [780653U04500G](#) [ATS-54310K-C2-R0](#) [FK 216 CB SA](#) [FK 231 SA 220](#) [648-51AB](#)