

ADJUSTABLE ACCURATE REFERENCE SOURCE

The TL431 is three-terminal adjustable shunt regulator with specified thermal stability.

The output voltage may be set to any value between V_{REF} (Approx. 2.5V) and 36V with two external resistors. This device has a typical output impedance of 0.2Ω .

Active output circuitry provides a very sharp turn-on characteristic, making this device excellent replacement for zener diodes in many application.

FEATURES

- Equivalent Full Range Temperature Coefficient 50PPM/°C
- Temperature Compensated For Operation Over Full Rate Operating Temperature Range
- Adjustable Output Voltage
- Fast Turn-on Response
- Sink Current Capability 1mA to 100mA
- Low (0.2Ω Typ.) Dynamic Output Impedance
- Low Output Noise

MARKING

TO-92	SOT-23	SOT-89
TF/TL431/A817 w TF/TL431/A818 w	431 \lrcorner w	431 w

*w: week code

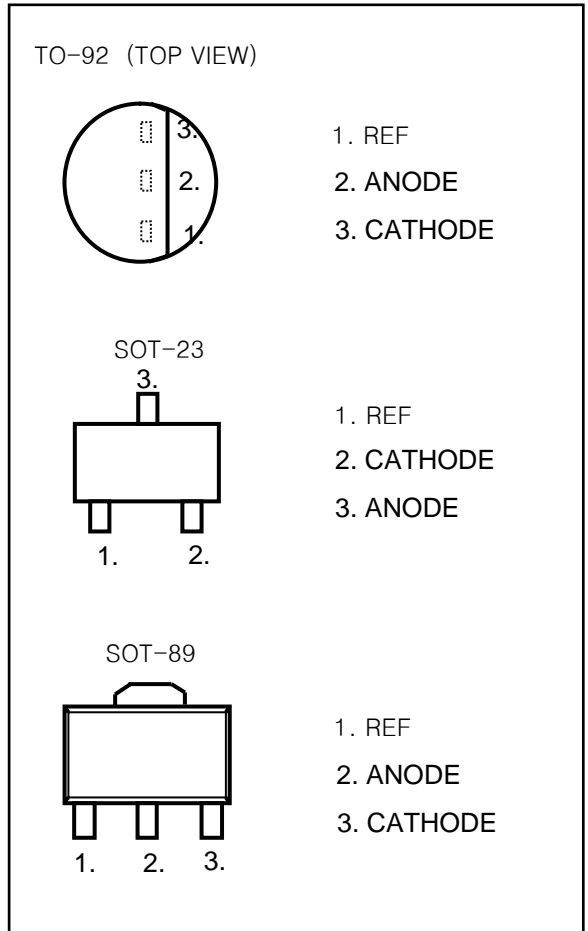

FUNCTION BLOCK DIAGRAM

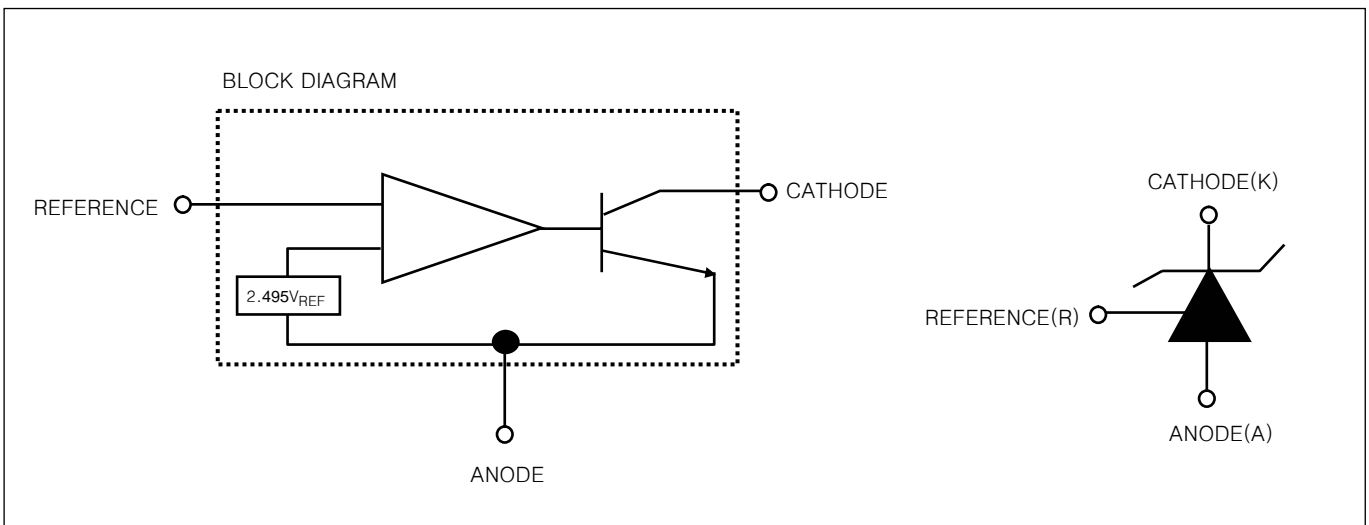



ABSOLUTE MAXIMUM RATINGS

(Full Operating Ambient Temperature Range Applies Unless Otherwise Noted)

CHARACTERISTIC	SYMBOL	RATING	UNIT
Cathode Voltage	V_{KA}	37	V
Continuous Cathode Current Range	I_{KA}	-100~+150	mA
Reference Input Current Range	I_{REF}	0.05~10	mA
Junction Temperature	T_J	150	°C
Operating Temperature	T_{OPR}	-20 ~ 85	°C
Storage Temperature	T_{STG}	-65 ~ 150	°C
Total Power Dissipation	P_D	700	mW

ELECTRICAL CHARACTERISTIC ($T_A=25^\circ\text{C}$, unless otherwise specified)

CHARACTERISTIC	SYMBOL	CIR-CUIT	TEST CONDITION	MIN.	TYP.	MAX.	UNIT
Deviation of Reference Input Voltage Over Full Temperature Range	$\Delta V_{REF}/\Delta T$	1	$V_{KA}=V_{REF}, I_K=10\text{mA}$ $T_A=\text{Full Range}$		3	17	mV
Ratio of Change in Reference Input Voltage to the Change in Cathode Voltage	$\Delta V_{REF}/\Delta V_{KA}$	2	$I_K=10\text{mA}$	$\Delta V_{KA}=10\text{V}-V_{REF}$	-1.4	-2.7	mV/V
				$\Delta V_{KA}=36\text{V}-10\text{V}$	-1	-2	
Reference Input Current	I_{REF}	2	$I_{KA}=10\text{mA}, R1=10\text{k}\Omega, R2=\infty$		1.8	4	μA
Deviation of Reference Input Current Over Full Temperature Range	$\Delta I_{REF}/\Delta T$	2	$I_K=10\text{mA}, R1=10\text{k}\Omega, R2=\infty$ $T_A=\text{Full Range}$		0.4	1.2	μA
Minimum Cathode Current for Regulation	I_{KMIN}	1	$\Delta V_{KA}=V_{REF}$		0.5	1	mA
Off-State Cathode Current	I_{KOFF}	3	$V_{KA}=36\text{V}, V_{REF}=0$		0.2	1	μA
Dynamic Impedance	Z_{KA}	1	$V_{KA}=V_{REF}, I_K=1\text{mA}\sim 100\text{mA},$ $f\leq 1\text{kHz}$		0.2	0.5	Ω

CLASSIFICATION OF V_{REF}

Rank	TYP.	0.3%	0.5%	1%
Range	2.495	2.487-2.502	2.482-2.507	2.470-2.520

Fig. 1 Test Circuit for $V_{KA} = V_{REF}$

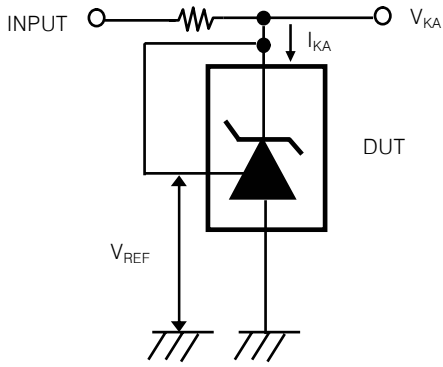

Fig. 2 Test Circuit for $V_{KA} \geq V_{REF}$

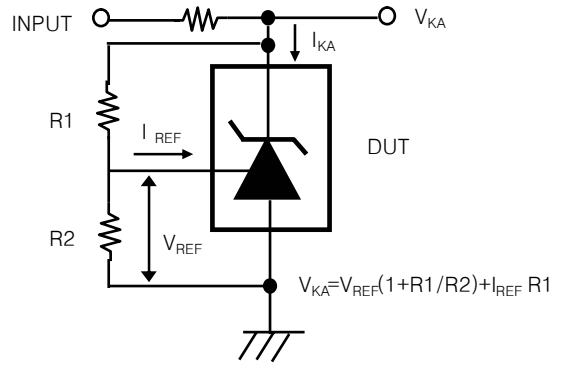
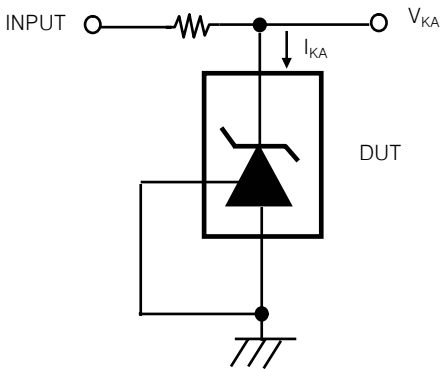
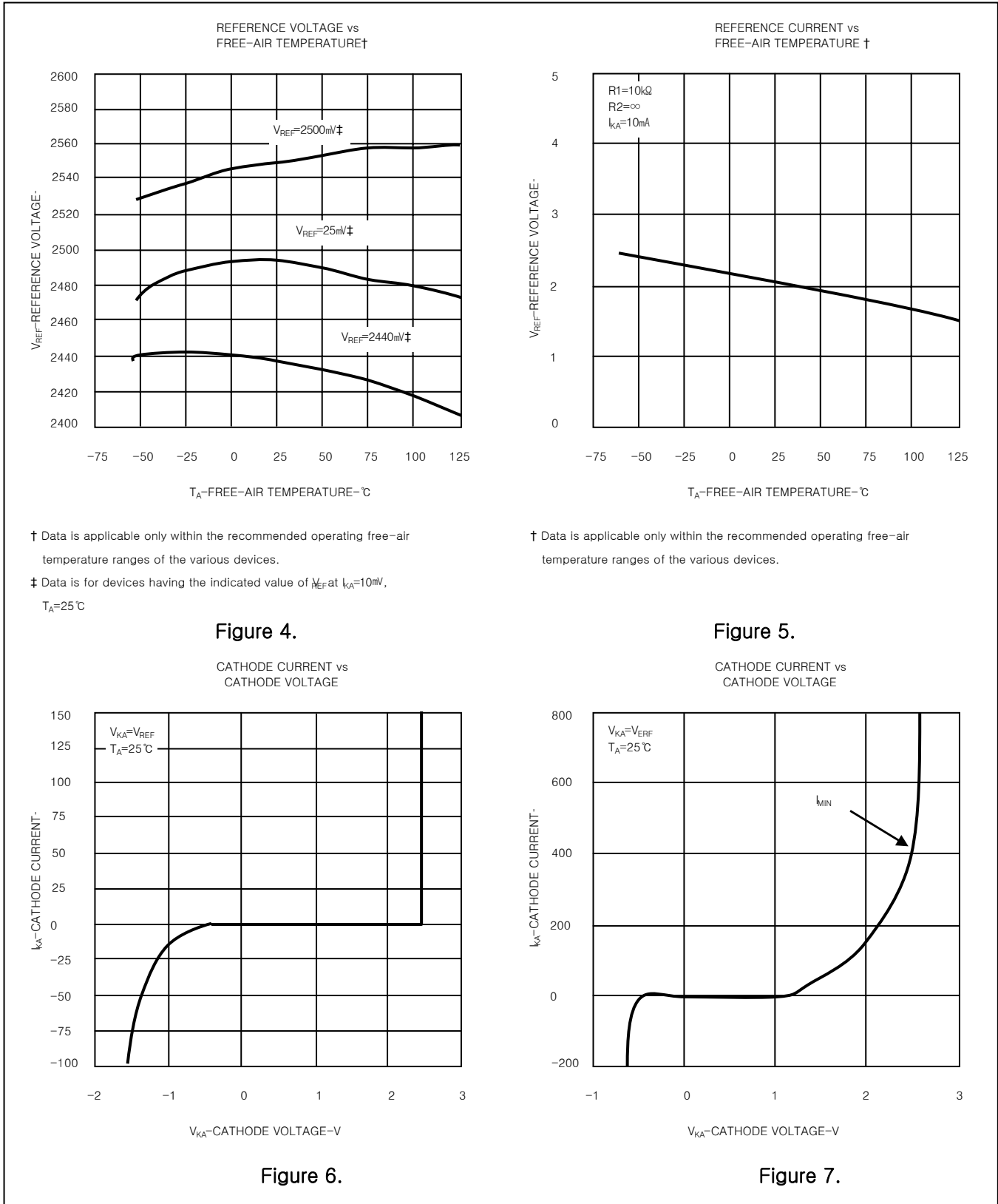

Fig. 3 Test Circuit for I_{KA} (off)



TYPICAL PERFORMANCE CHARACTERISTICS



TYPICAL PERFORMANCE CHARACTERISTICS

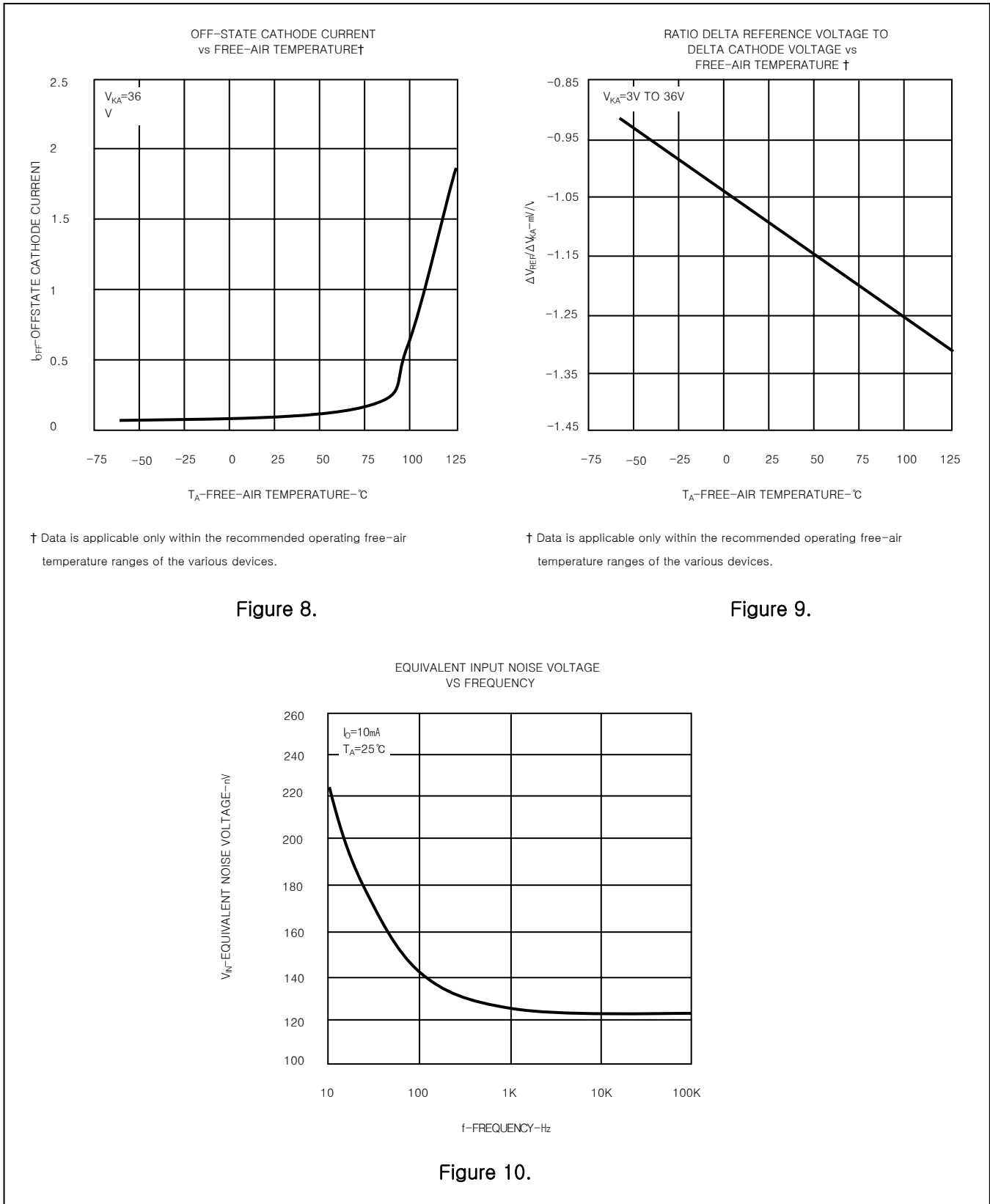

TYPICAL PERFORMANCE CHARACTERISTICS

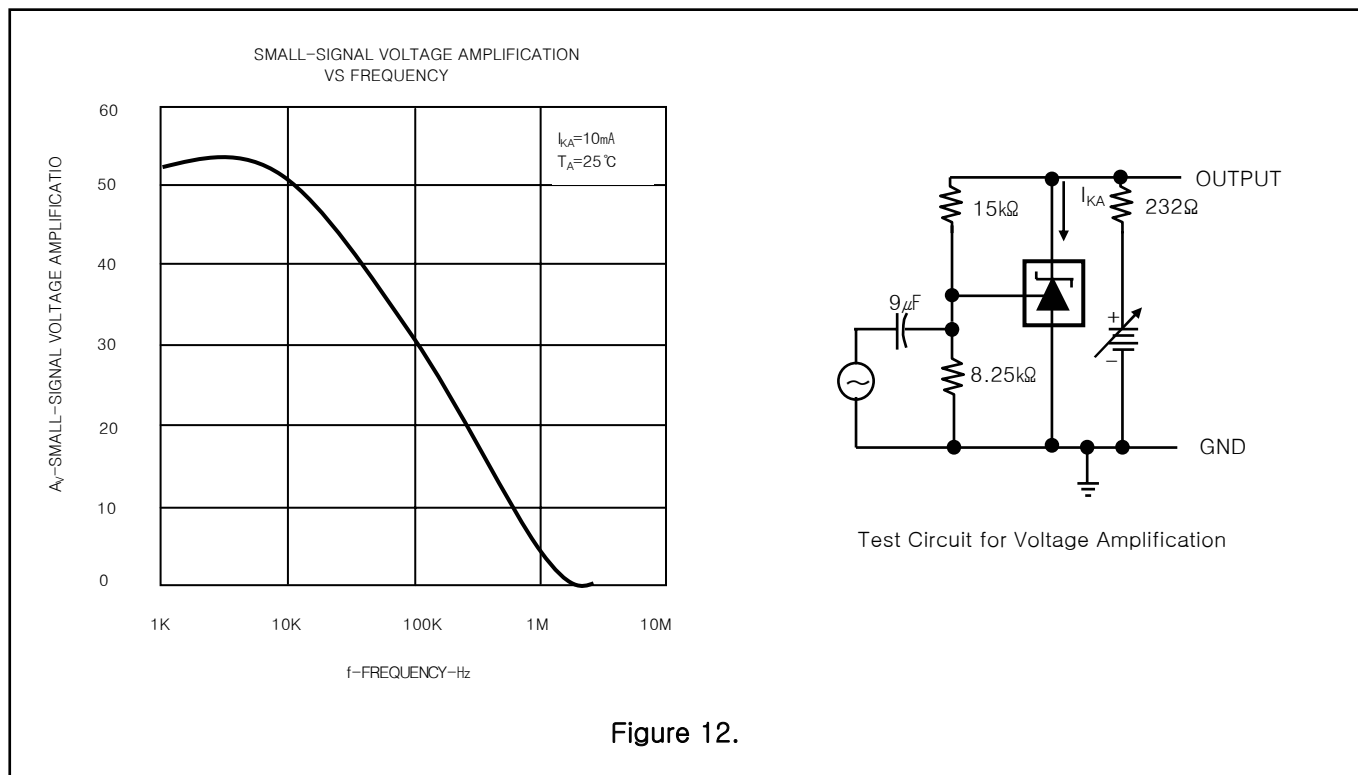
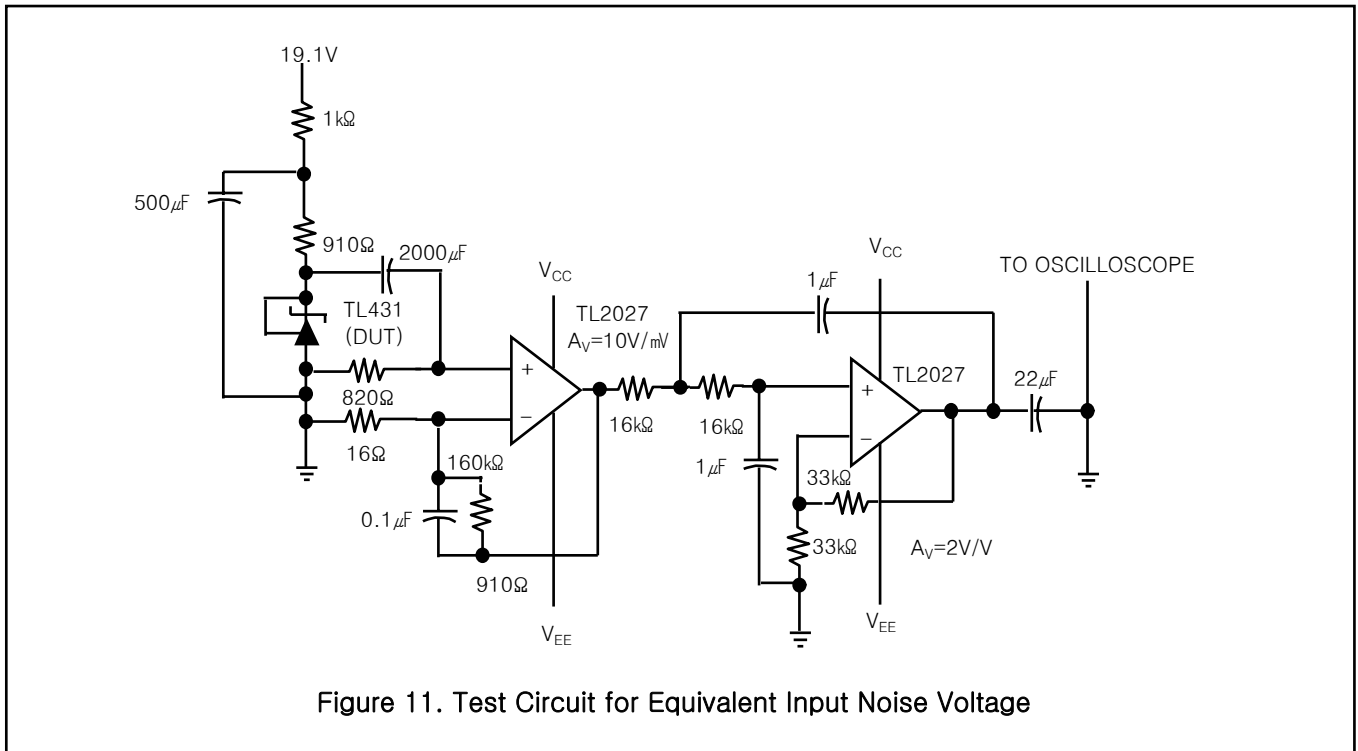

TYPICAL PERFORMANCE CHARACTERISTICS

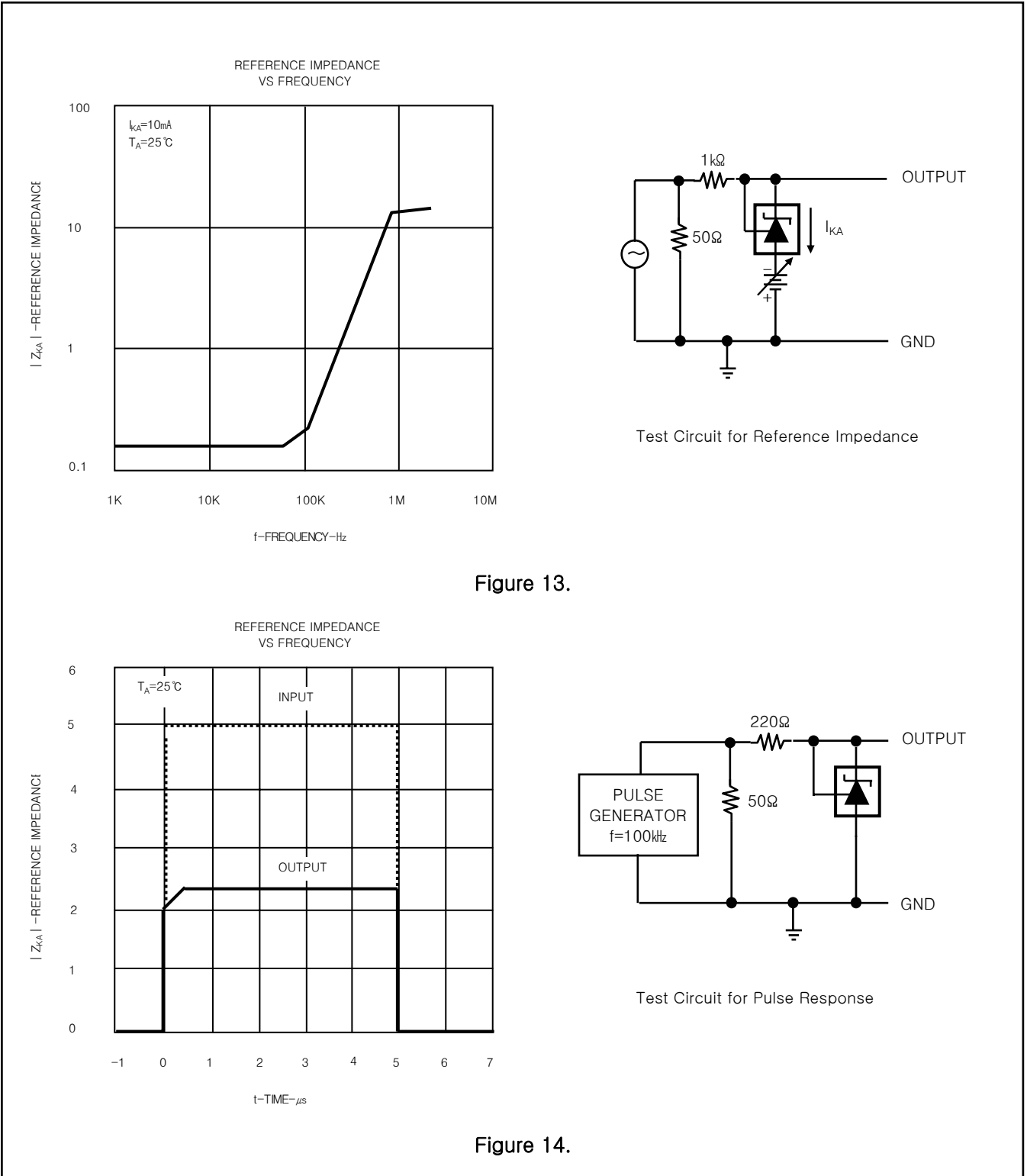
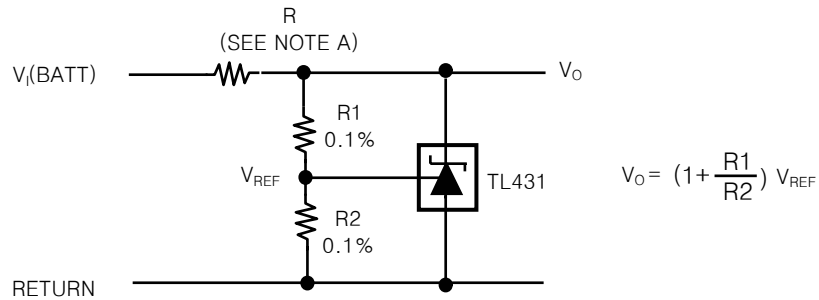

Figure 13.

Figure 14.

APPLICATION INFORMATION



NOTE A : R Should provide cathode current $\geq 1\text{ mA}$ to the TL431 at minimum $V_i(\text{BATT})$

Figure 15. Shunt Regulator

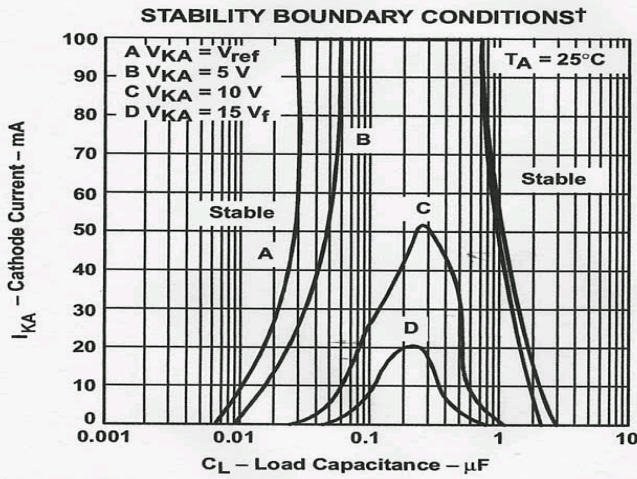

† The areas under the curves represent conditions that may cause the device to oscillate. For curves B, C, and D, R2 and V+ were adjusted to establish the initial V_{KA} and I_{KA} conditions with $C_L = 0$. V_{BATT} and C_L then were adjusted to determine the ranges of stability.

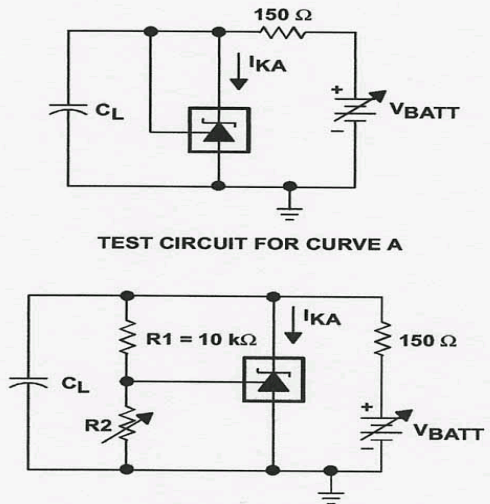
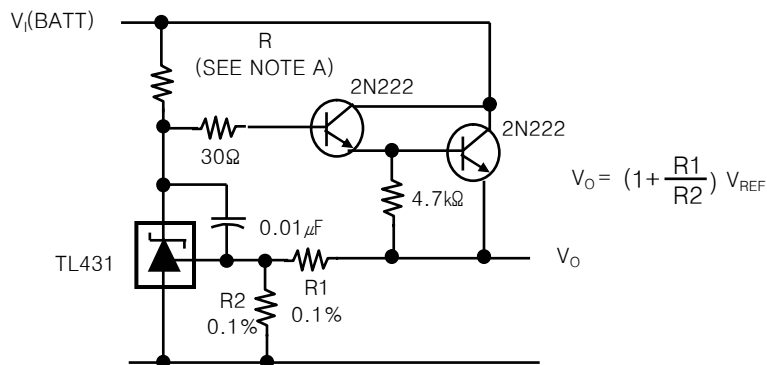

Figure 16



NOTE A : R Should provide cathode current $\geq 1\text{ mA}$ to the TL431 at minimum $V_i(\text{BATT})$

Figure 17. Precision High-Current Series Regulator

APPLICATION INFORMATION

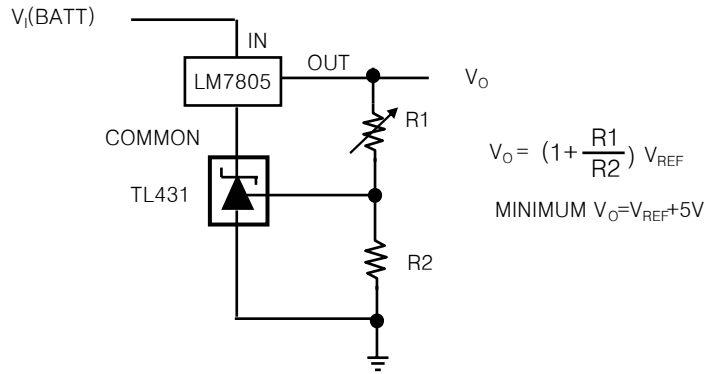

Figure 18. Output Control of a 3-Terminal Fixed Regulator

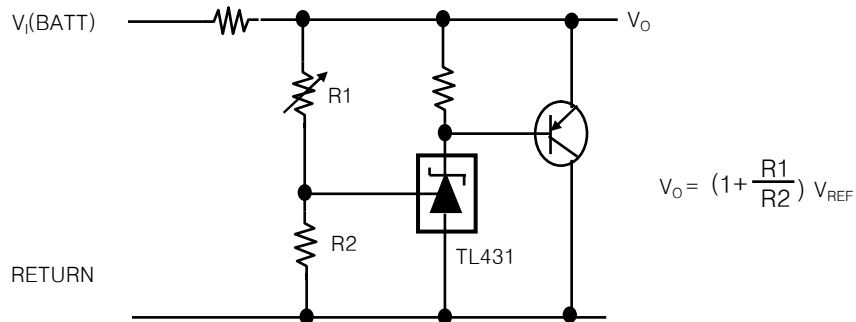
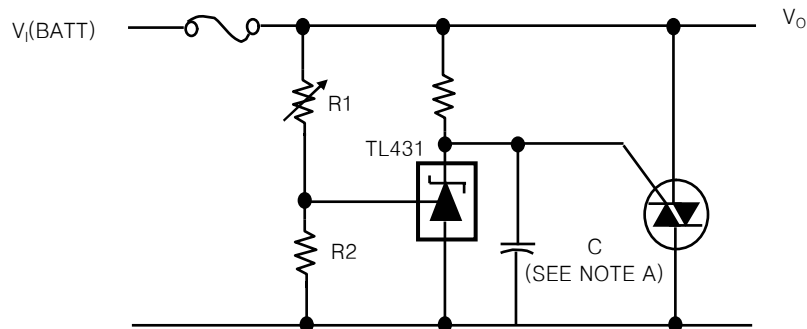

Figure 19. High-Current Shunt Regulator



NOTE A : Refer to the stability boundary conditions in Figure 16 to determine allowable values for C.

Figure 20. Crowbar Circuit

APPLICATION INFORMATION

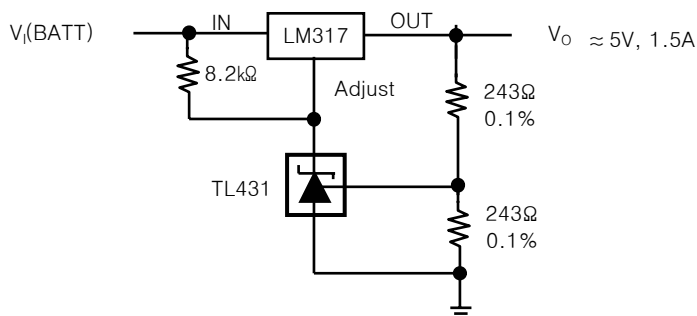
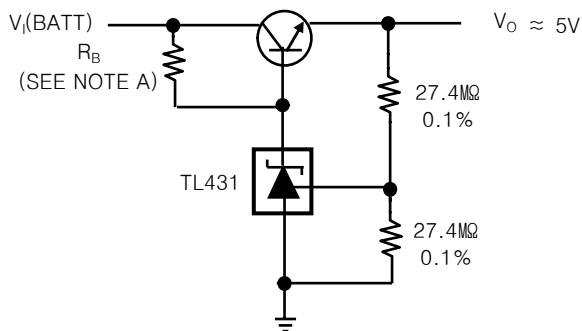

Figure 21. Precision 5-V 1.5A Regulator



NOTE A : R_B Should provide cathode current $\geq 1\text{mA}$ to the TL431.

Figure 22. Efficient 5-V Precision Regulator

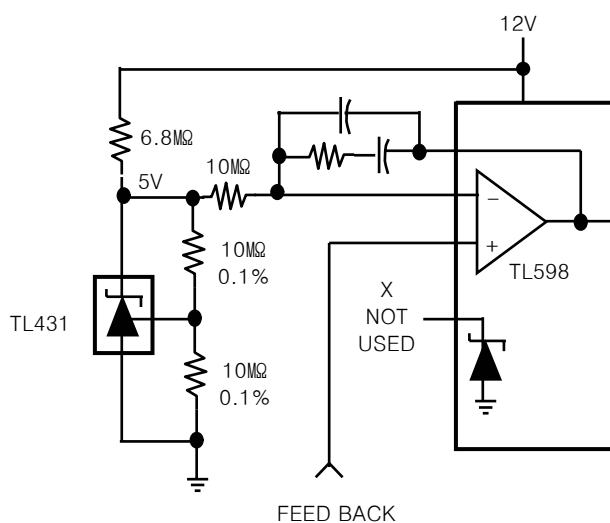
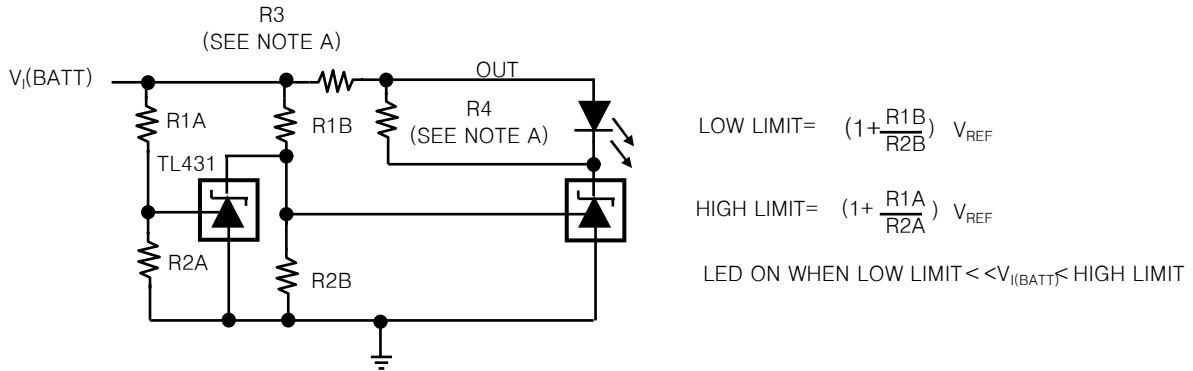

Figure 23. PWM Converter With Reference

APPLICATION INFORMATION



NOTE A : R3 and R4 are selected to provide the desired LED intensity and cathode current ≥ 1 mA to the TL431 at the available $V_{I(BATT)}$.

Figure 24. Voltage Monitor

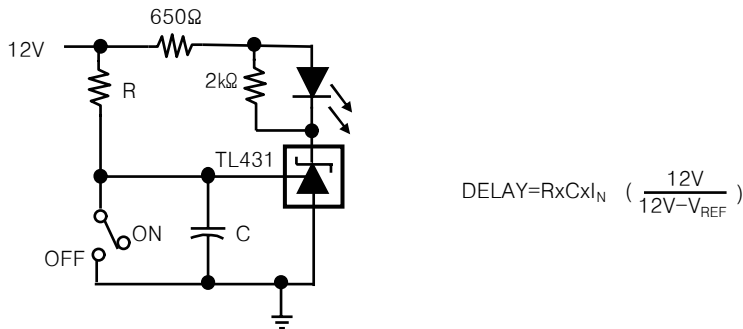

Figure 25. Delay Timer

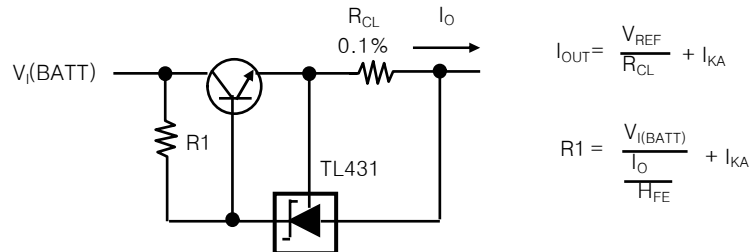

Figure 26. Precision Current Limiter

APPLICATION INFORMATION

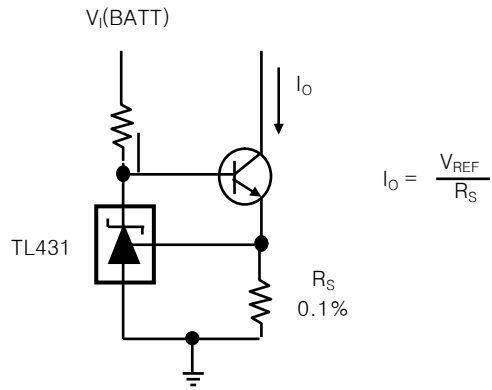
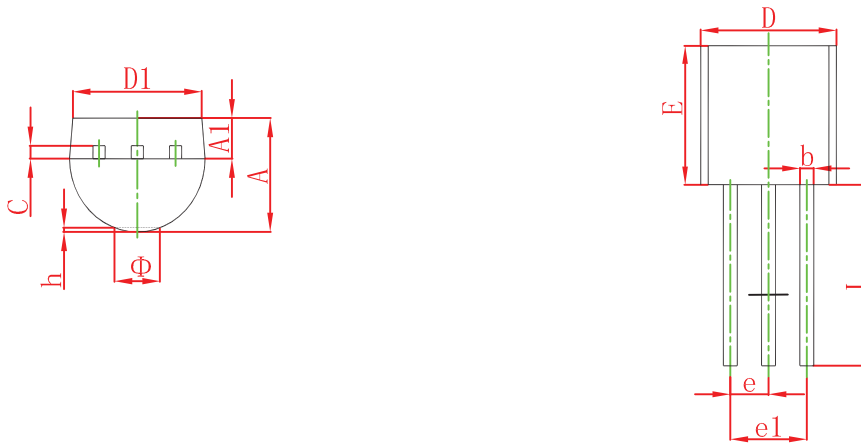

Figure 27. Precision Constant-Current Sink

TO-92 Package Outline Dimensions



Symbol	Dimensions In Millimeters		Dimensions In Inches	
	Min	Max	Min	Max
A	3.300	3.700	0.130	0.146
A1	1.100	1.400	0.043	0.055
b	0.380	0.550	0.015	0.022
c	0.360	0.510	0.014	0.020
D	4.300	4.700	0.169	0.185
D1	3.430		0.135	
E	4.300	4.700	0.169	0.185
e	1.270 TYP		0.050 TYP	
e1	2.440	2.640	0.096	0.104
L	14.100	14.500	0.555	0.571
Φ		1.600		0.063
h	0.000	0.380	0.000	0.015

TO-92 Suggested Pad Layout

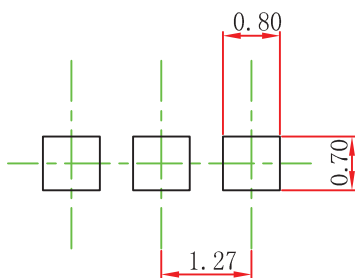

- Note:
1. Controlling dimension: in millimeters.
 2. General tolerance: $\pm 0.05\text{mm}$.
 3. The pad layout is for reference purposes only.

SOT-23 Package Outline Dimensions

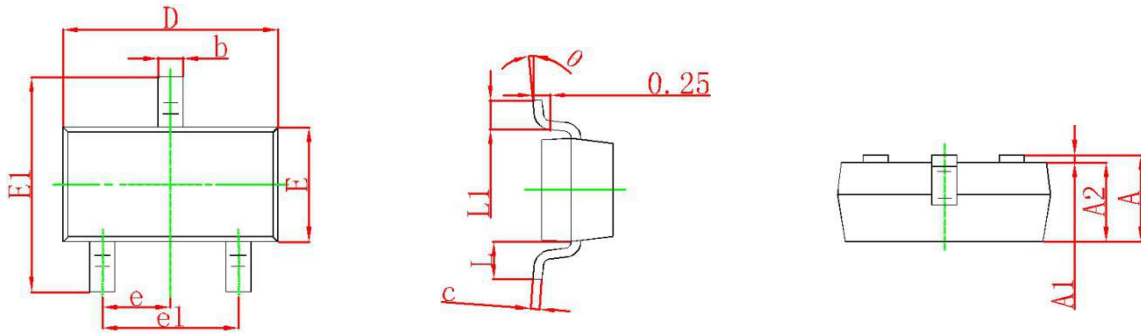

Symbol	Dimensions In Millimeters		Dimensions In Inches	
	Min	Max	Min	Max
A	0.900	1.150	0.035	0.045
A1	0.000	0.100	0.000	0.004
A2	0.900	1.050	0.035	0.041
b	0.300	0.500	0.012	0.020
c	0.080	0.150	0.003	0.006
D	2.800	3.000	0.110	0.118
E	1.200	1.400	0.047	0.055
E1	2.250	2.550	0.089	0.100
e	0.950 TYP		0.037 TYP	
e1	1.800	2.000	0.071	0.079
L	0.550 REF		0.022 REF	
L1	0.300	0.500	0.012	0.020
θ	0°	8°	0°	8°

SOT-23 Suggested Pad Layout

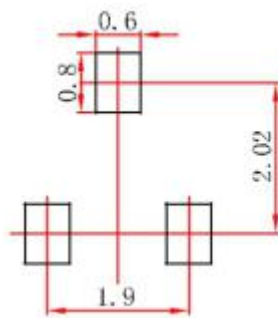

Note:

1. Controlling dimension: in millimeters.
2. General tolerance: $\pm 0.05\text{mm}$.
3. The pad layout is for reference purposes only.

SOT-89-3L Package Outline Dimensions

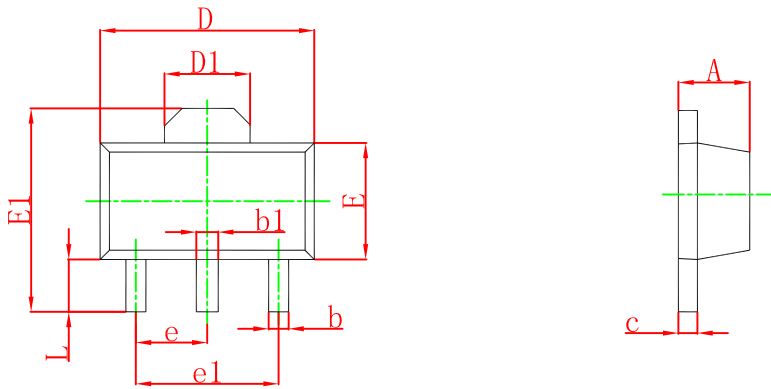

Symbol	Dimensions In Millimeters		Dimensions In Inches	
	Min	Max	Min	Max
A	1.400	1.600	0.055	0.063
b	0.320	0.520	0.013	0.020
b1	0.400	0.580	0.016	0.023
c	0.350	0.440	0.014	0.017
D	4.400	4.600	0.173	0.181
D1	1.550 REF.		0.061 REF.	
E	2.300	2.600	0.091	0.102
E1	3.940	4.250	0.155	0.167
e	1.500 TYP.		0.060 TYP.	
e1	3.000 TYP.		0.118 TYP.	
L	0.900	1.200	0.035	0.047

SOT-89-3L Suggested Pad Layout

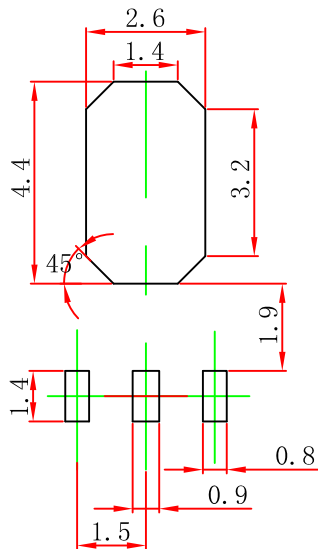

Note:

1. Controlling dimension: in millimeters.
2. General tolerance: ± 0.05 mm.
3. The pad layout is for reference purposes only.

X-ON Electronics

Largest Supplier of Electrical and Electronic Components

Click to view similar products for [tuofeng](#) manufacturer:

Other Similar products are found below :

[1117-1.8V](#) [TF3402](#) [TIP127A](#) [8205S](#) [TF3400](#) [2045](#) [68N80](#) [90N03](#) [TF3407](#) [TF2310](#) [78L15](#) [78L06](#) [DW01A](#) [TF2306](#) [TF2301](#) [1117-1.2V](#)
[TF2305B](#) [10N60](#) [SLF6N70U](#) [TF3414](#) [TF3423](#) [431\(1.5%\)](#) [68N75](#) [TF3415](#) [TF3401](#)