

ESD Protector Overvoltage Protection Device

BENEFITS

- ESD protection for high frequency applications (HDMI 1.3)
- Smaller form factor for board space savings
- Helps protect electronic circuits against damage from electrostatic discharge (ESD) events
- Assists equipment to pass IEC 61000-4-2, level 4 testing

FEATURES

- 0.15 pF (typ) Capacitance
- Low leakage current
- Low clamping voltage
- Fast response time (<1ns)
- Capable of withstanding numerous ESD strikes
- Compatible with standard reflow installation procedures
- Thick film technology
- Bi-directional protection

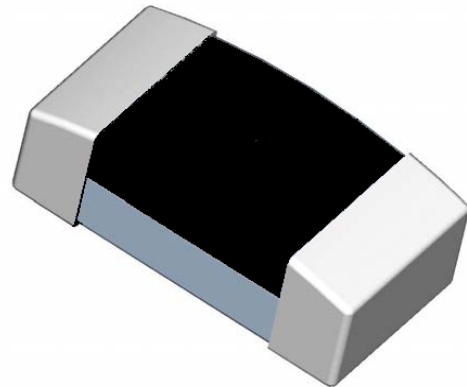

APPLICATIONS

- HDMI 1.3 interface
- LCD, HDTV
- Cellular phones
- Antennas (cell phones, GPS...)
- Portable video devices (PDA, DSC, Bluetooth...)
- Printer ports
- High speed Ethernet
- USB 2.0 and IEEE 1394 interfaces
- DVI interface

CAUTION: This device should not be used in Power Bus applications

MATERIALS INFORMATION

RoHS Compliant

Directive 2002/95/EC
Compliant

ELV Compliant

Directive 2000/53/EC
Compliant

Halogen Free*



Lead Free



* Halogen Free refers to: Br≤900ppm, Cl≤900ppm, Br+Cl≤1500ppm

TYPICAL DEVICE RATINGS AND CHARACTERISTICS

Symbol	Continuous Max Operating Voltage	Typical TLP Trigger Voltage ¹	Typical TLP Clamping Voltage ¹ after 30ns	Typical Capacitance ² @ 1 MHz, 1V _{rms}	Typical Leakage Current @14V _{DC}	Max Leakage Current @14V _{DC}
	V _{DC}	V _{T(TLP)}	V _{C(TLP 30)}	Cp	I _{L(Typ)}	I _{L(MAX)}
Unit	V	V	V	pF	μA	μA
Value	24	250	40	0.15	<0.01	10.0

Note 1: TLP test method at 1000V (refer to FIG. 5 on page 5)

Note 2: Typical capacitance @ 0V and 14V bias

GENERAL CHARACTERISTICS

Operating temperature: -55°C to +125°C

Storage temperature: -40°C to +85°C

ESD voltage capability (tested per IEC 61000-4-2)

- Contact discharge mode: 8kV (typ), 15kV (max)
- Air discharge mode: 15kV (typ), 25kV (max) [1 pulse: per customer request]

ESD pulse withstand: Typically 100 pulses (tested per IEC 61000-4-2, level 4, and contact method)

Environmental Specifications

Test Conditions	Bias Humidity Test	Thermal Shock	Bias Heat Test	Bias Low Temp Test	Solderability	Solder Heat	Vibration	Mechanical Shock	Solvent Resistance
	@ 85°C @ 85% RH V _{DC} (max) 1000 hours	-55°C to 125°C 30min dwell 1000 cycles	@ 125°C V _{DC} (max) 1000 hours	@ -55°C V _{DC} (max) 1000 hours	250 °C +/- 5 °C 3s +/- 1s	260 °C, 10s	10 to 50Hz, 60s cycle, 2hrs each in X-Y-Z axis	1500G, 0.5ms, X-Y-Z axis 3 times	IPA ultrasonic 300s
Pass/Fail Criteria	I _L ≤ 10μA	I _L ≤ 10μA	I _L ≤ 10μA	I _L ≤ 10μA	95% coverage	90% coverage	No Physical Damage I _L ≤ 10 μA	No Physical Damage I _L ≤ 10 μA	No Physical Damage I _L ≤ 10 μA

FIG 1: CAPACITANCE VS. FREQUENCY (TYPICAL SAMPLE)
 (Flat Response of Capacitance over Frequency Range)

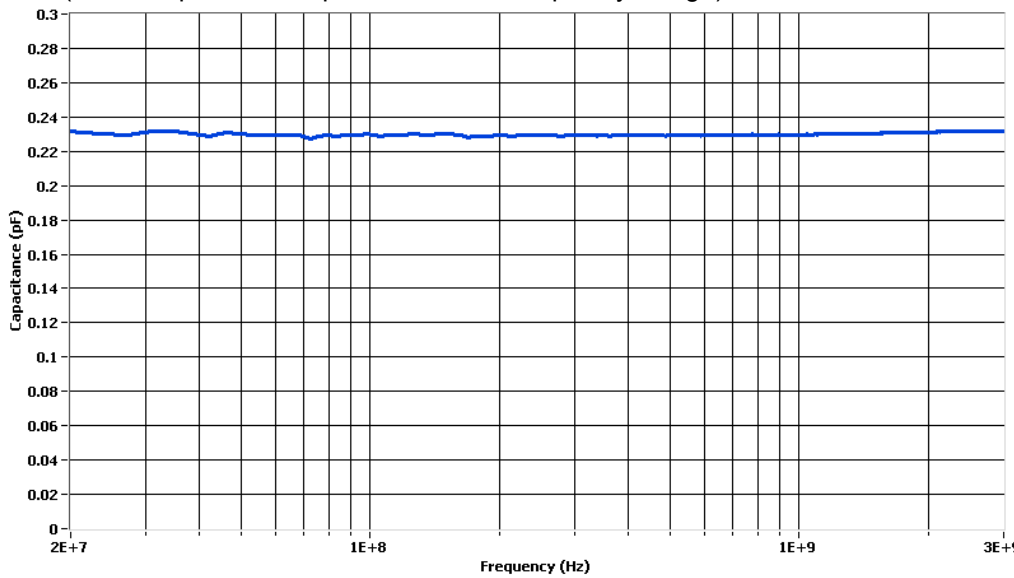

FIG 2: EYE DIAGRAM (TYPICAL SAMPLE)
 (Eye Diagram Performance at 3.4 GHz— meets criteria for HDMI 1.3)

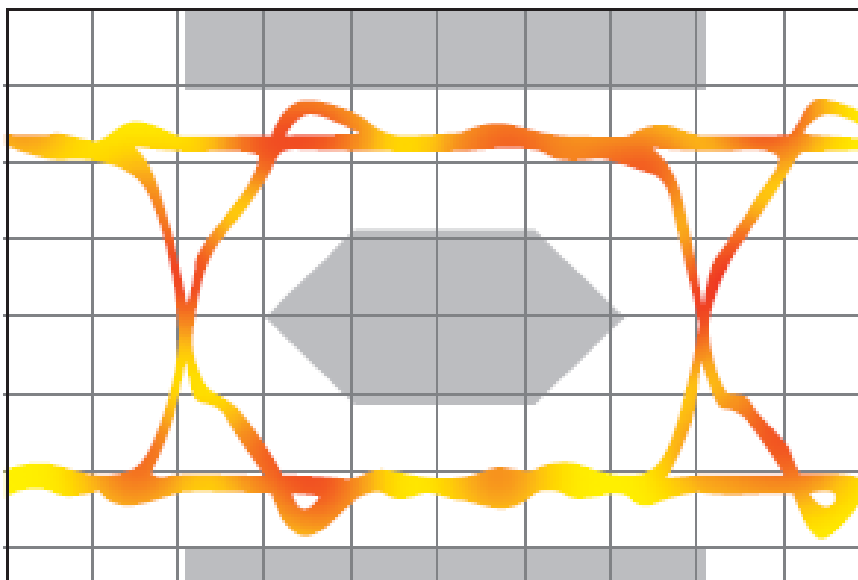

FIG 3: INSERTION LOSS DIAGRAM (TYPICAL SAMPLE)

(Minimal Insertion Loss at 3.4 GHz)

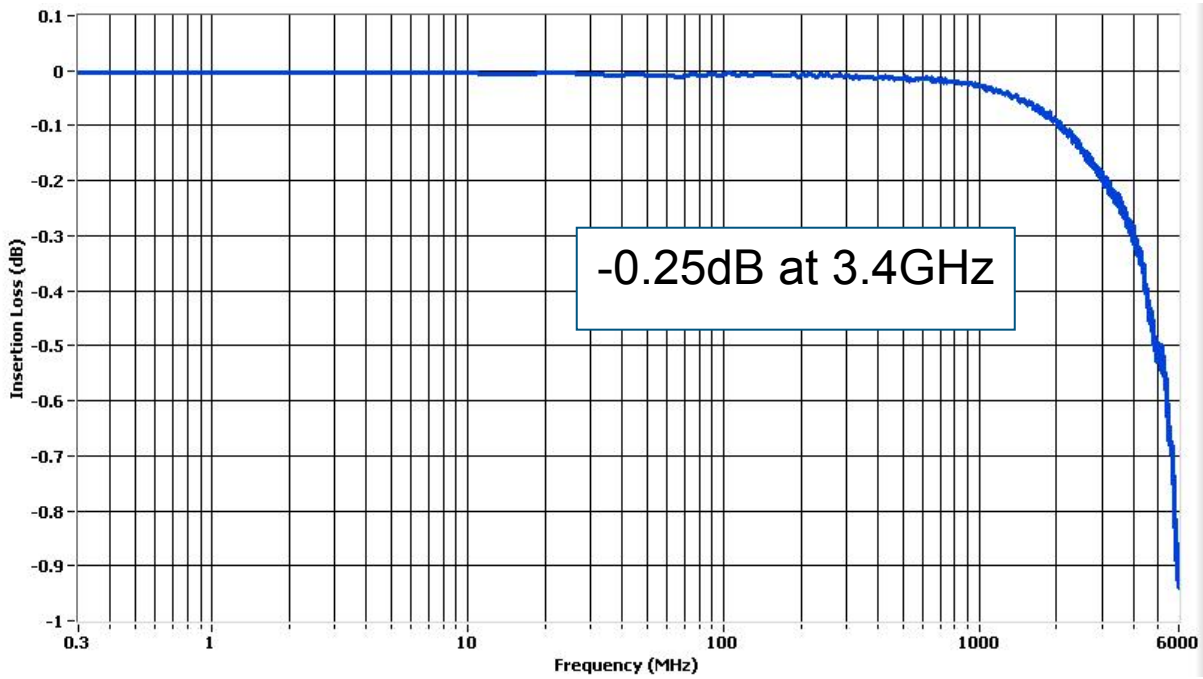

FIG 4: ESD PROTECTION FOR HDMI

(Reference Layout and Test Results available)

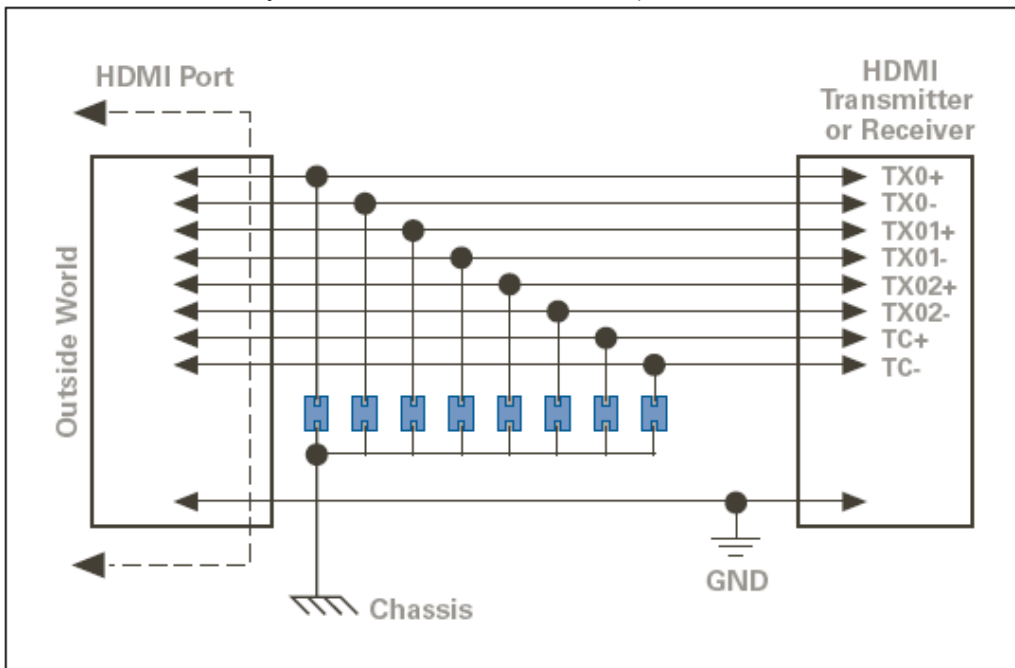
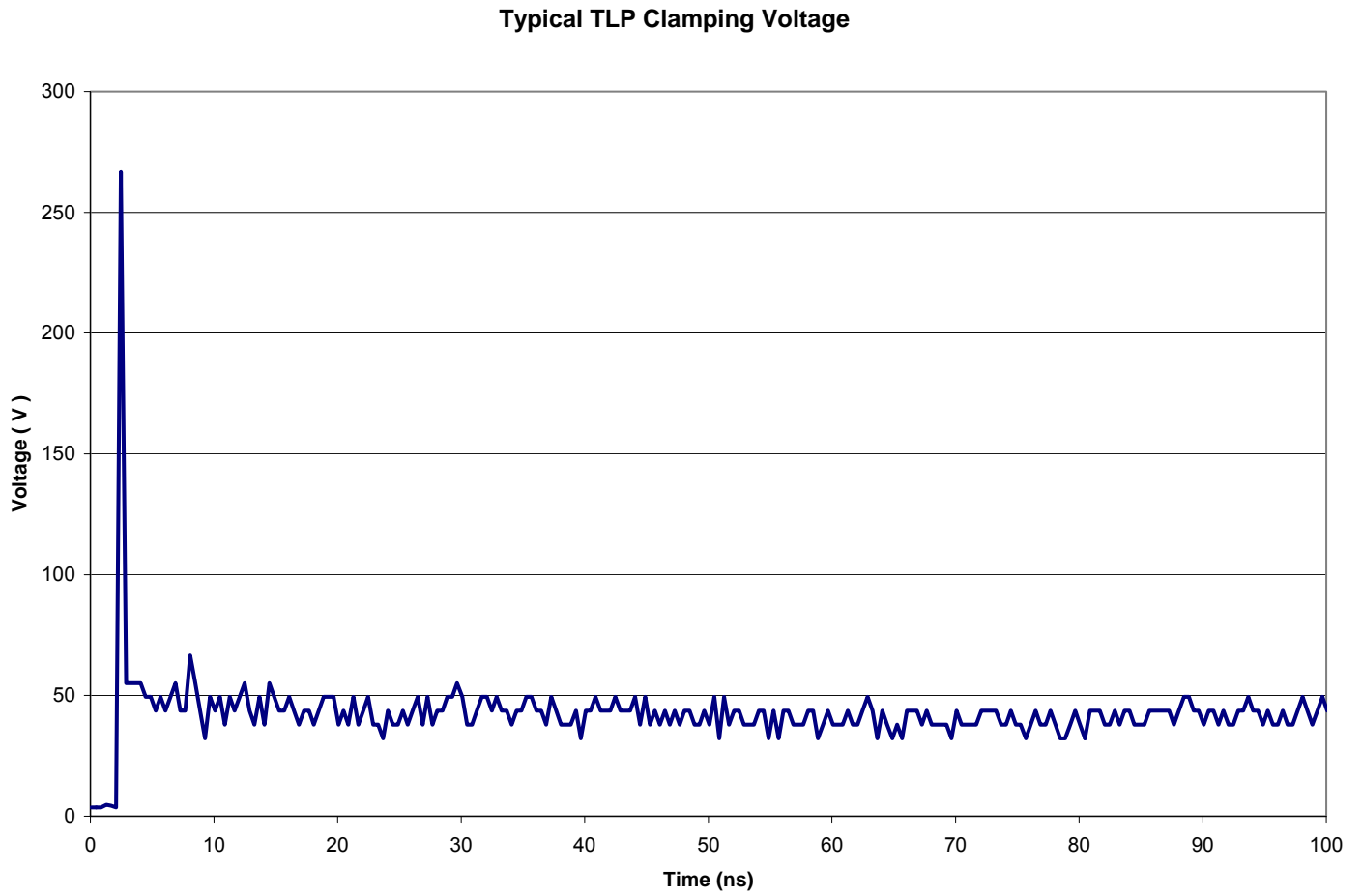
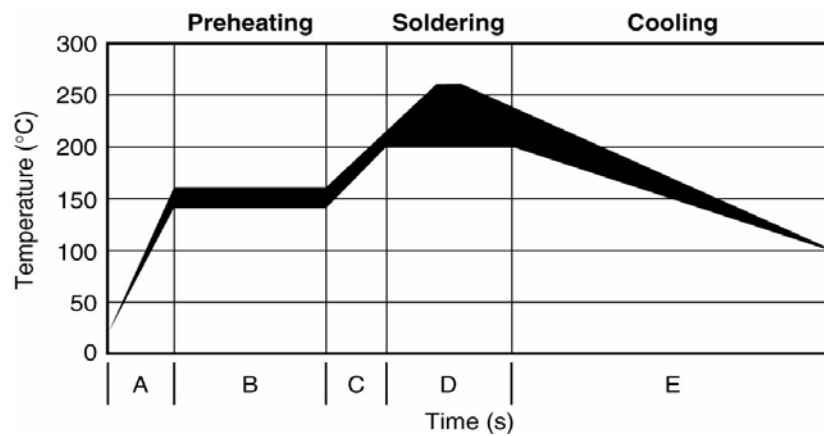

FIG 5: TYPICAL TRANSMISSION LINE PULSE RESPONSE GRAPH



SOLDER REFLOW RECOMMENDATIONS:

A	Temperature ramp up 1	From ambient to Preheating temperature	30s to 60s
B	Preheating	140°C - 160°C	60s to 120s
C	Temperature ramp up 2	From Preheating to Main heating temperature	20s to 40s
D	Main heating	at 200°C at 220°C at 240°C at 260°C	60s ~ 70s 50s ~ 60s 30s ~ 40s 5s ~ 10s
E	Cooling	From main heating temperature to 100°C	4°C/s (max)



DIMENSIONS

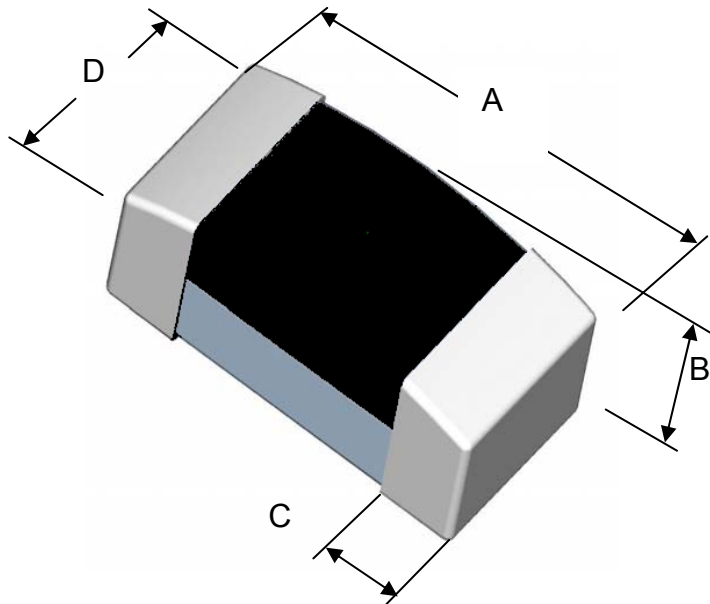

Drawing Not To Scale

	Length A		Height B		Terminal Width C		Width D	
	Min	Max	Min	Max	Min	Max	Min	Max
mm	1.50	1.70	0.40	0.60	0.20	0.40	0.70	0.90
in*	(0.059)	(0.067)	(0.016)	(0.024)	(0.008)	(0.016)	(0.027)	(0.035)

* Round off approximation

RECOMMENDED LAND PATTERN:

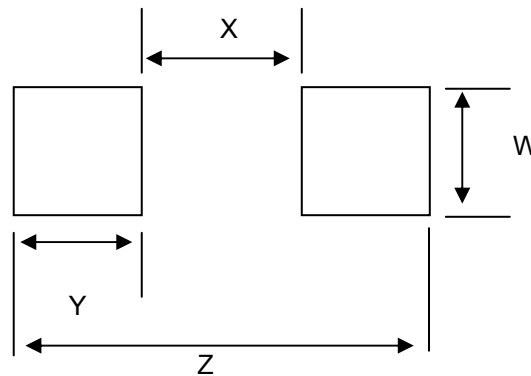

	W		X		Y		Z	
	Min	Max	Min	Max	Min	Max	Min	Max
mm	0.90	1.00	0.50	0.60	1.00	1.10	2.70	2.80
in*	(0.035)	(0.039)	(0.020)	(0.024)	(0.039)	(0.043)	(0.106)	(0.110)

* Round off approximation

X-ON Electronics

Largest Supplier of Electrical and Electronic Components

Click to view similar products for [ESD Suppressors / TVS Diodes](#) category:

Click to view products by [TWGMC](#) manufacturer:

Other Similar products are found below :

[NTE4902](#) [P4SMAJ15A](#) [P4SMAJ26A](#) [SMAJ400CA-TP](#) [TGL34-47CA](#) [ESDAULC45-1BF4](#) [SM1605E3/TR13](#) [SMF20A-TP](#) [P4SMAJ12A](#)
[CPDUR24V-HF](#) [CPDQC5V0USP-HF](#) [CPDQC5V0-HF](#) [MPLAD30KP280A](#) [MPLAD30KP45CAE3](#) [MMBZ27VCLQ-7-F](#) [MMAD1108/TR13](#)
[MPLAD30KP24A](#) [MPLAD30KP30CAE3](#) [ACPDQC5V0R-HF](#) [DFLT170A-7](#) [NTE4900](#) [NTE4926](#) [NTE4938](#) [JANTX1N6144A](#)
[JANTX1N6057A](#) [SMF22A-TP](#) [SMF12A-TP](#) [SLVU2.8-TP](#) [SMLJ6.5CA-TP](#) [SMAJ6.5CA-TP](#) [MMAD1108E3/TR13](#) [JANTX1N6160A](#)
[D5V0M1U2LP3-7](#) [SMAJ400A-TP](#) [AOZ8811DT-03](#) [AOZ8831DI-05](#) [AOZ8831DT-03](#) [SMAJ188CA](#) [3SMC33CA BK](#) [CPDQC3V3C-HF](#)
[CPDQC12VE-HF](#) [GRPADATAJANTX1N6041A](#) [MPLAD30KP170CA](#) [82357120100](#) [5.0SMLJ15CA-TP](#) [5KP18A-TP](#) [P6KE8.2A-TP](#)
[MPLAD30KP43CAE3](#) [SMAJ43A-TP](#) [D26V0H1U2LP16-7](#)