

## Low-Power, Slew-Rate-Limited RS-485/RS-422 Transceivers

### General Description

The MAX485ESA is low-power transceivers for RS-485 and RS-422 communication. IC contains one driver and one receiver. The driver slew rates of the MAX485ESA is not limited, allowing them to transmit up to 2.5Mbps. These transceivers draw between 120 $\mu$ A and 500 $\mu$ A of supply current when unloaded or fully loaded with disabled drivers. All parts operate from a single 5V supply. Drivers are short-circuit current limited and are protected against excessive power dissipation by thermal shutdown circuitry that places the driver outputs into a high-impedance state. The receiver input has a fail-safe feature that guarantees a logic-high output if the input is open circuit. The MAX485ESA is designed for half-duplex applications.

### Features

- Low Quiescent Current: 300 $\mu$ A
- -7V to +12V Common-Mode Input Voltage Range
- Three-State Outputs
- 30ns Propagation Delays, 5ns Skew
- Full-Duplex and Half-Duplex Versions Available
- Operate from a Single 5V Supply
- Allows up to 32 Transceivers on the Bus
- Data rate: 2,5 Mbps
- Current-Limiting and Thermal Shutdown for Driver Overload Protection

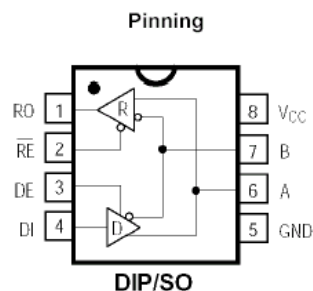

**ABSOLUTE MAXIMUM RATINGS**

Supply Voltage ( $V_{CC}$ ) 12V  
 Control Input Voltage -0.5V to ( $V_{CC} + 0.5V$ )  
 Driver Input Voltage (DI) -0.5V to ( $V_{CC} + 0.5V$ )  
 Driver Output Voltage (A, B) -8V to +12.5V  
 Receiver Input Voltage (A, B) -8V to +12.5V  
 Receiver Output Voltage (RO) -0.5V to ( $V_{CC} + 0.5V$ )

Continuous Power Dissipation ( $T_A = +70^\circ\text{C}$ )  
 8-Pin Plastic DIP (derate 9.09mW/ $^\circ\text{C}$  above +70 $^\circ\text{C}$ ) 727mW  
 8-Pin SO (derate 5.88mW/ $^\circ\text{C}$  above +70 $^\circ\text{C}$ ) 471mW  
 Operating Temperature Ranges -40 $^\circ\text{C}$  to +85 $^\circ\text{C}$   
 Storage Temperature Range -65 $^\circ\text{C}$  to +160 $^\circ\text{C}$   
 Lead Temperature (soldering, 10sec) +300 $^\circ\text{C}$

**DC ELECTRICAL CHARACTERISTICS**

( $V_{CC} = 5V \pm 5\%$ ,  $T_A = T_{MIN}$  to  $T_{MAX}$ , unless otherwise noted.) (Notes 1, 2)

PARAMETER	SYMBOL	CONDITIONS	MIN	TYP	MAX	UNITS
Differential Driver Output (no load)	$V_{OD1}$				5	V
Differential Driver Output (with load)	$V_{OD2}$	R = 50 $\Omega$ (RS-422)	2			V
		R = 27 $\Omega$ (RS-485), Figure 4	1.5		5	V
Change in Magnitude of Driver Differential Output Voltage for Complementary Output States	$\Delta V_{OD}$	R = 27 $\Omega$ or 50 $\Omega$ , Figure 4			0.2	V
Driver Common-Mode Output Voltage	$V_{OC}$	R = 27 $\Omega$ or 50 $\Omega$ , Figure 4			3	V
Change in Magnitude of Driver Common-Mode Output Voltage for Complementary Output States	$\Delta V_{OD}$	R = 27 $\Omega$ or 50 $\Omega$ , Figure 4			0.2	V
Input High Voltage	$V_{IH}$	DE, DI, $\overline{RE}$	2.0			V
Input Low Voltage	$V_{IL}$	DE, DI, $\overline{RE}$			0.8	V
Input Current	$I_{IN1}$	DE, DI, $\overline{RE}$			$\pm 2$	$\mu\text{A}$
Input Current (A, B)	$I_{IN2}$	DE = 0V; $V_{CC} = 0V$ or 5.25V,	$V_{IN} = 12V$		1.0	mA
			$V_{IN} = -7V$		-0.8	
Receiver Differential Threshold Voltage	$V_{TH}$	-7V $\leq V_{CM} \leq 12V$	-0.2		0.2	V
Receiver Input Hysteresis	$\Delta V_{TH}$	$V_{CM} = 0V$		70		mV
Receiver Output High Voltage	$V_{OH}$	$I_O = -4\text{mA}$ , $V_{ID} = 200\text{mV}$	3.5			V
Receiver Output Low Voltage	$V_{OL}$	$I_O = 4\text{mA}$ , $V_{ID} = -200\text{mV}$			0.4	V
Three-State (high impedance) Output Current at Receiver	$I_{OZR}$	0.4V $\leq V_O \leq 2.4V$			$\pm 1$	$\mu\text{A}$
Receiver Input Resistance	$R_{IN}$	-7V $\leq V_{CM} \leq 12V$				k $\Omega$

**DC ELECTRICAL CHARACTERISTICS (continued)**

 ( $V_{CC} = 5V \pm 5\%$ ,  $T_A = T_{MIN}$  to  $T_{MAX}$ , unless otherwise noted.) (Notes 1, 2)

PARAMETER	SYMBOL	CONDITIONS	MIN	TYP	MAX	UNITS
No-Load Supply Current (Note 3)	$I_{CC}$	$DE = V_{CC}$		500	900	$\mu A$
		$RE = 0V$ or $V_{CC}$		300	500	
		$DE = 0V$				
Driver Short-Circuit Current,						
	$I_{OSD1}$	$-7V \leq V_O \leq 12V$ (Note 4)	35		250	$mA$
$V_O = High$						
Driver Short-Circuit Current,						
	$I_{OSD2}$	$-7V \leq V_O \leq 12V$ (Note 4)	35		250	$mA$
$V_O = Low$						
Receiver Short-Circuit Current	$I_{OSR}$	$0V \leq V_O \leq V_{CC}$	7		95	$mA$

**SWITCHING CHARACTERISTICS**

 ( $V_{CC} = 5V \pm 5\%$ ,  $T_A = T_{MIN}$  to  $T_{MAX}$ , unless otherwise noted.) (Notes 1, 2)

PARAMETER	SYMBOL	CONDITIONS	MIN	TYP	MAX	UNITS
Driver Input to Output	$t_{PLH}$	$R_{DIFF} = 54\Omega$	10	30	60	$ns$
	$t_{PHL}$	$C_{L1} = C_{L2} = 100pF$	10	30	60	
Driver Output Skew to Output	$t_{SKEW}$	$R_{DIFF} = 54\Omega$ , $C_{L1} = C_{L2} = 100pF$		5	10	$ns$
Driver Enable to Output High	$t_{ZH}$	$C_L = 100pF$ , S2 closed		40	70	$ns$
Driver Enable to Output Low	$t_{ZL}$	$C_L = 100pF$ , S1 closed		40	70	$ns$
Driver Disable Time from Low	$t_{LZ}$	$C_L = 15pF$ , S1 closed		40	70	$ns$
Driver Disable Time from High	$t_{HZ}$	$C_L = 15pF$ , S2 closed		40	70	$ns$
$t_{PLH} - t_{PHL}$   Differential	$t_{SKD}$	$R_{DIFF} = 54\Omega$		13		$ns$
Receiver Skew		$C_{L1} = C_{L2} = 100pF$				
Receiver Enable to Output Low	$t_{ZL}$	$C_{RL} = 15pF$ , S1 closed		20	50	$ns$
Receiver Enable to Output High	$t_{ZH}$	$C_{RL} = 15pF$ , S2 closed		20	50	$ns$
Receiver Disable Time from Low	$t_{LZ}$	$C_{RL} = 15pF$ , S1 closed		20	50	$ns$
Receiver Disable Time from High	$t_{HZ}$	$C_{RL} = 15pF$ , S2 closed		20	50	$ns$
Maximum Data Rate	$f_{MAX}$		2.5			$Mbps$

Operation timing diagrams of MAX485ESA

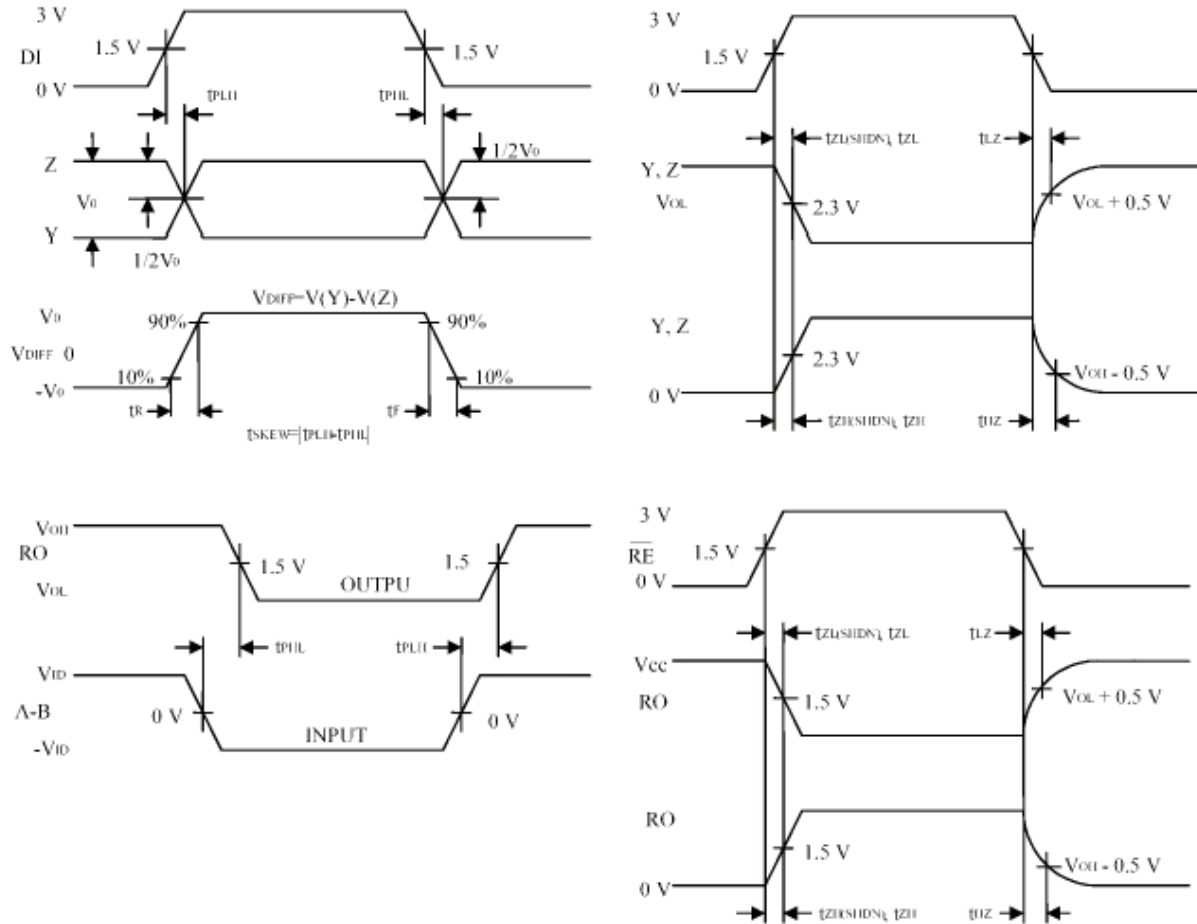
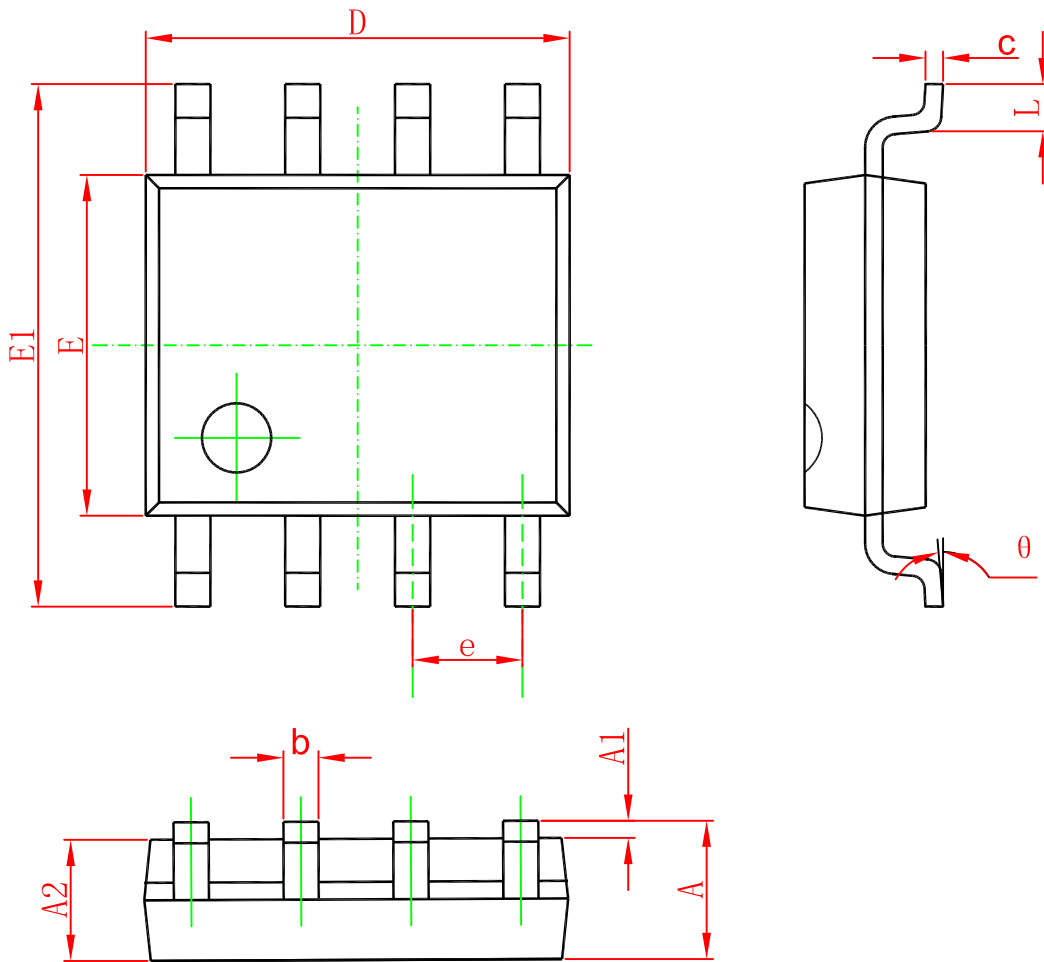

Table of MAX485ESA operation

Transmission					Receipt			
Inputs			Outputs X		Inputs			Outputs
RE	DE	DI	Z	Y	RE	DE	A-B	RO
X	1	1	0	1	0	0	+0.2V	1
X	1	0	1	0	0	0	-0.2V	0
0	0	X	Z	Z	0	0	open	1
1	0	X	Z	Z	1	0	X	Z

X-don't care  
Z-high resistance

**SOP-8**

Symbol	Dimensions In Millimeters		Dimensions In Inches	
	Min	Max	Min	Max
A	1.350	1.750	0.053	0.069
A1	0.100	0.250	0.004	0.010
A2	1.350	1.550	0.053	0.061
b	0.330	0.510	0.013	0.020
c	0.170	0.250	0.006	0.010
D	4.700	5.100	0.185	0.200
E	3.800	4.000	0.150	0.157
E1	5.800	6.200	0.228	0.244
e	1.270(BSC)		0.050(BSC)	
L	0.400	1.270	0.016	0.050
θ	0°	8°	0°	8°

## X-ON Electronics

Largest Supplier of Electrical and Electronic Components

*Click to view similar products for [RS-422/RS-485 Interface IC category](#):*

*Click to view products by [TWGMC manufacturer](#):*

Other Similar products are found below :

[SP3494CN-L/TR](#) [SP3494EN-L/TR](#) [SP3085EEN-L/TR](#) [XR33038IDTR-F](#) [BL3085\(I47\)](#) [BL1587](#) [MAX13085](#) [SSP3485](#) [SSP485N](#)  
[MAX3485ESA](#) [SP3485EEN](#) [MAX485ESA](#) [ST485EBDR](#) [SN65LBC184DR](#) [ST3485EBDR](#) [SN75176BDR](#) [ADM3485EARZ](#)  
[SN75LBC184DR](#) [SN65176BDR](#) [BL3085N\(I56\)](#) [HT485ARZ](#) [UM3486EESA](#) [GB490H](#) [SP485EN](#) [UM3085EESA](#) [SN65HVD07EIM/TR](#)  
[SSP3485U](#) [GB490](#) [COS485RS](#) [BL3085A\(H\)](#) [CS48520S](#) [DS3486M/TR](#) [MS2375](#) [SL3485S](#) [BL1590](#) [UM3352EESA](#) [HGX3485EIMM/TR](#)  
[HGX3485ECMM/TR](#) [SP3485EIMM/TR](#) [MAX3085EIMM/TR](#) [MAX3085ECMM/TR](#) [SP3085ECMM/TR](#) [MAX3485EIMM/TR](#)  
[MAX3485ECMM/TR](#) [HT6575ARZ](#) [SN65HVD75DR](#) [CA-IS2092W](#) [GM3085N](#) [GM490E](#) [WS3085W](#)