

General Description

SN74LVC1G14 is A non-gate integrated circuit with Schmitt-triggered function, which can achieve $Y=\bar{A}$ mathematical logic operation. Advanced CMOS process design, with low power consumption and high output driving capability, the power supply voltage V_{CC} between 1.65V and 5.5V chip can work normally. 74LVC1G14 has a variety of small encapsulation shapes, which can be widely used in high-end precision instruments, miniaturized and low-power handheld devices, as well as artificial intelligence and other fields.

Features

- Low input current.
- Low static power consumption. $I_{CC}=0.1\mu A$.
- High output drive. $V_{CC}=4.5V$.
- Wide operating voltage range. 1.65V-5.5V
- Packaging form: DBV/DRL/YZP/DCK DRP/DSF/DPW

Applications

- Portable audio interface
- Blu-ray players and home theaters
- Solid state drives
- Digital TV
- Wireless headphones, smart watches, etc
- Smart wearable Devices

Pinning and Package

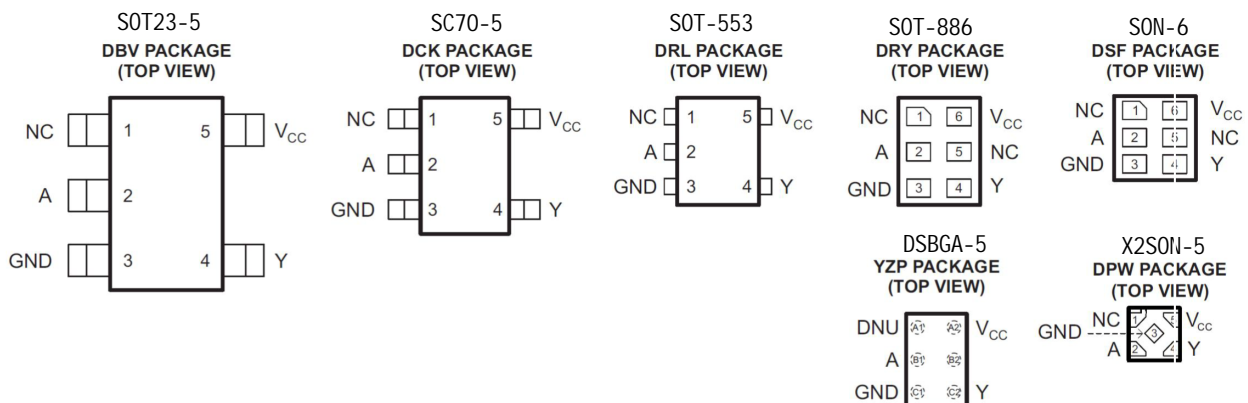

Pin Functions

NAME	PIN				I/O	DESCRIPTION
	DBV, DCK, DRL, DPW	DRY, DSF	YZP	YZV		
A	2	2	B1	A1	I	Signal Input
GND	3	3	C1	B1	—	Ground
N.C.	1	1, 5	—	—	—	No internal connection ⁽¹⁾
DNU	—	—	A1	—	—	Do not use ⁽²⁾
V_{CC}	5	6	A2	A2	—	Positive Supply
Y	4	4	C2	B2	O	Signal Output

(1) Pins labeled N.C. can be connected to any signal or voltage source, including ground. They should always be soldered to the board.
 (2) Pins labeled DNU should not be connected to any signal or voltage source, including ground. They should always be soldered to the board.

Absolute Maximum Ratings

over operating free-air temperature range (unless otherwise noted)

		MIN	MAX	UNIT
V _{CC}	Supply voltage	-0.5	6.5	V
V _I	Input voltage ⁽²⁾	-0.5	6.5	V
V _O	Voltage range applied to any output in the high-impedance or power-off state ⁽²⁾	-0.5	6.5	V
V _O	Voltage range applied to any output in the high or low state ⁽²⁾ ⁽³⁾	-0.5	V _{CC} + 0.5	V
I _{IK}	Input clamp current	V _I < 0	-50	mA
I _{OK}	Output clamp current	V _O < 0	-50	mA
I _O	Continuous output current		±50	mA
	Continuous current through V _{CC} or GND		±100	mA
T _j	Maximum junction temperature		150	°C
T _{stg}	Storage temperature	-65	150	°C

- (1) Stresses beyond those listed under *Absolute Maximum Ratings* may cause permanent damage to the device. These are stress ratings only, which do not imply functional operation of the device at these or any other conditions beyond those indicated under *Recommended Operating Conditions*. Exposure to absolute-maximum-rated conditions for extended periods may affect device reliability.
- (2) The input and output negative-voltage ratings may be exceeded if the input and output current ratings are observed.
- (3) The value of V_{CC} is provided in the recommended operating conditions table.

Functional Block Diagram

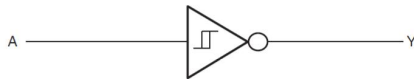

Device Functional Modes

Inputs	Output
A	Y
L	H
H	L

Recommended Operating Conditions

		MIN	MAX	UNIT	
V _{CC}	Supply voltage	Operating	1.65	5.5	V
		Data retention only	1.5		
V _{IH}	High-level input voltage	V _{CC} = 1.65 V to 1.95 V	0.65 × V _{CC}	V	
		V _{CC} = 2.3 V to 2.7 V	1.7		
		V _{CC} = 3 V to 5.5 V	0.7 × V _{CC}		
V _{IL}	Low-level input voltage	V _{CC} = 1.65 V to 1.95 V	0.35 × V _{CC}	V	
		V _{CC} = 2.3 V to 2.7 V	0.7		
		V _{CC} = 3 V to 5.5 V	0.3 × V _{CC}		
V _I	Input voltage	0	5.5	V	
V _O	Output voltage	0	V _{CC}	V	
I _{OH}	High-level output current	V _{CC} = 1.65 V	-4	mA	
		V _{CC} = 2.3 V	-8		
		V _{CC} = 3 V	-16		
		V _{CC} = 4.5 V	-32		
I _{OL}	Low-level output current	V _{CC} = 1.65 V	4	mA	
		V _{CC} = 2.3 V	8		
		V _{CC} = 3 V	16		
		V _{CC} = 4.5 V	32		

Electrical Characteristics

PARAMETER		TEST CONDITIONS	V _{CC}	TYP	MAX	UNIT
V _{T+}		-	1.65V	1	-	V
			2.3V	1.35	-	
			3V	1.7	-	
			4.5V	2.5	-	
			5.5V	3	-	
V _{T-}		-	1.65V	0.5	-	V
			2.3V	0.7	-	
			3V	1.1	-	
			4.5V	1.65	-	
			5.5V	1.9	-	
ΔV_T (V _{T+} - V _{T-})		-	1.65V	0.5	-	V
			2.3V	0.65	-	
			3V	0.6	-	
			4.5V	0.85	-	
			5.5V	1.1	-	
V _{OH}		I _{OH} = -100uA	1.65V~5.5V	1.64	-	V
		I _{OH} = -4 mA	1.65V	1.47	-	
		I _{OH} = -8 mA	2.3V	2.15	-	
		I _{OH} = -16 mA	3V	2.73	-	
		I _{OH} = -32 mA	4.5V	4.0	-	
V _{OL}		I _{OH} = 100uA	1.65V~5.5V	0.01	-	V
		I _{OH} = 4 mA	1.65V	0.11	-	
		I _{OH} = 8 mA	2.3V	0.11	-	
		I _{OH} = 16 mA	3V	0.2	-	
		I _{OH} = 32 mA	4.5V	0.35	-	
I _I	A	V _I = 5.5V or GND	0~5.5V	0.01	±5	uA
I _{OFF}	V _I	V _I = 5.5V	0	0.01	±10	uA
	V _O	V _O = 5.5V	0	0.01	±10	
I _{CC}		V _I = 5.5V, I _O = 0	1.65V~5.5V	0.01	10	uA
		V _I = GND, I _O = 0		0.01	10	
ΔI_{CC}		A = V _{CC} - 0.6V	3V~5.5V	25	-	uA

Switching Characteristics: -40°C to 85°C

 over recommended operating free-air temperature range², (-40 C to 85°C unless otherwise noted) (see)

PARAMETER	FROM (INPUT)	TO (OUTPUT)	V _{CC}	C _L = 15 pF		C _L = 30 pF or 50 pF		UNIT
				MIN	MAX	MIN	MAX	
t _{pd}	A	Y	1.8 V ± 0.15 V	2.8	9.9	3.8	11	ns
			2.5 V ± 0.2 V	1.6	5.5	2	6.5	
			3.3 V ± 0.3 V	1.5	4.6	1.8	5.5	
			5 V ± 0.5 V	0.9	4.4	1.2	5	

DBV (SOT23-5)

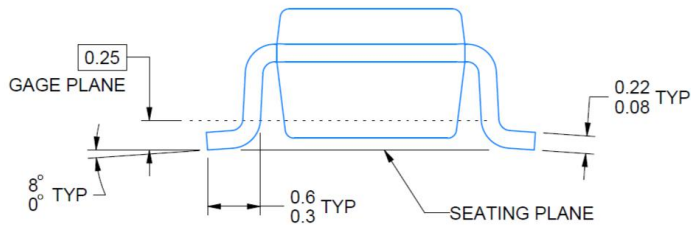
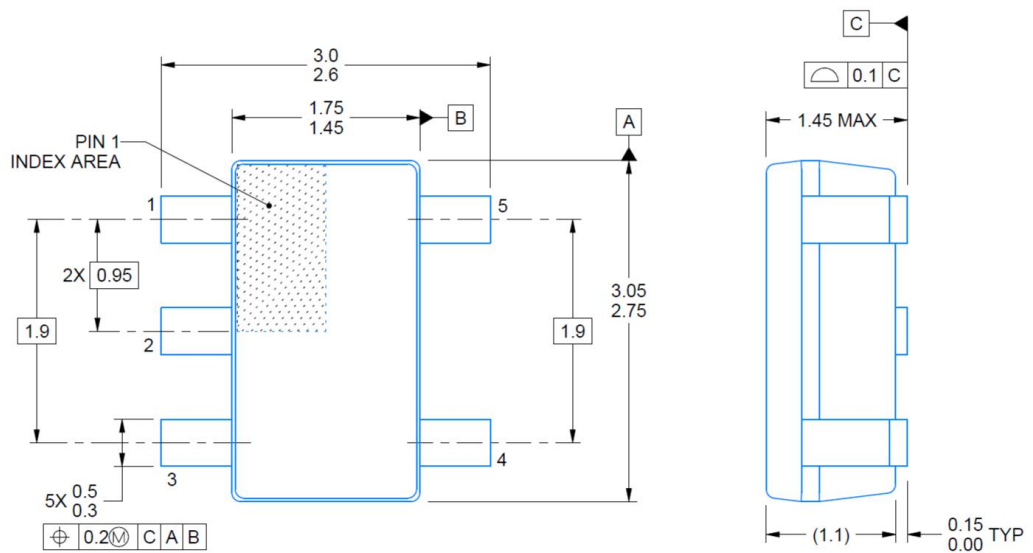

Marking

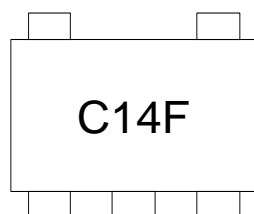

DCK (SC70-5)

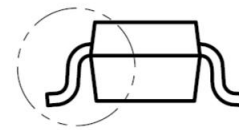
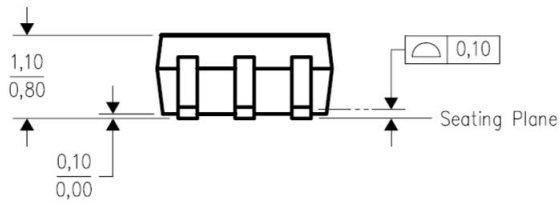
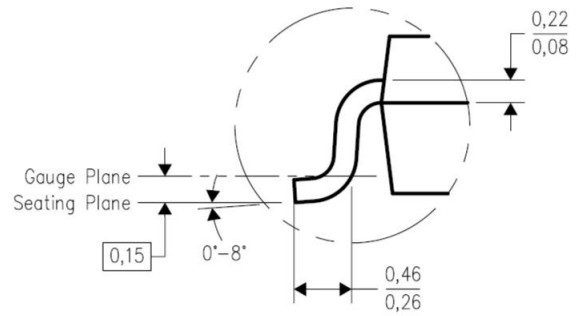
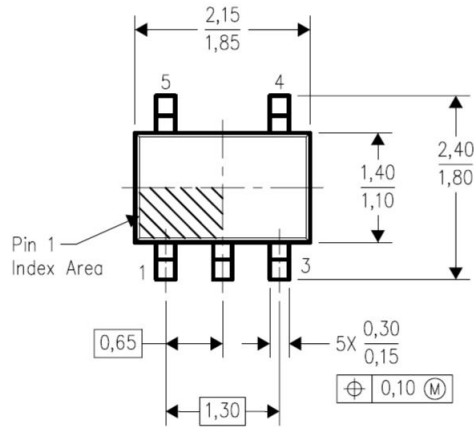

Marking

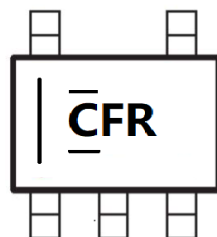

DRL (SOT-553)

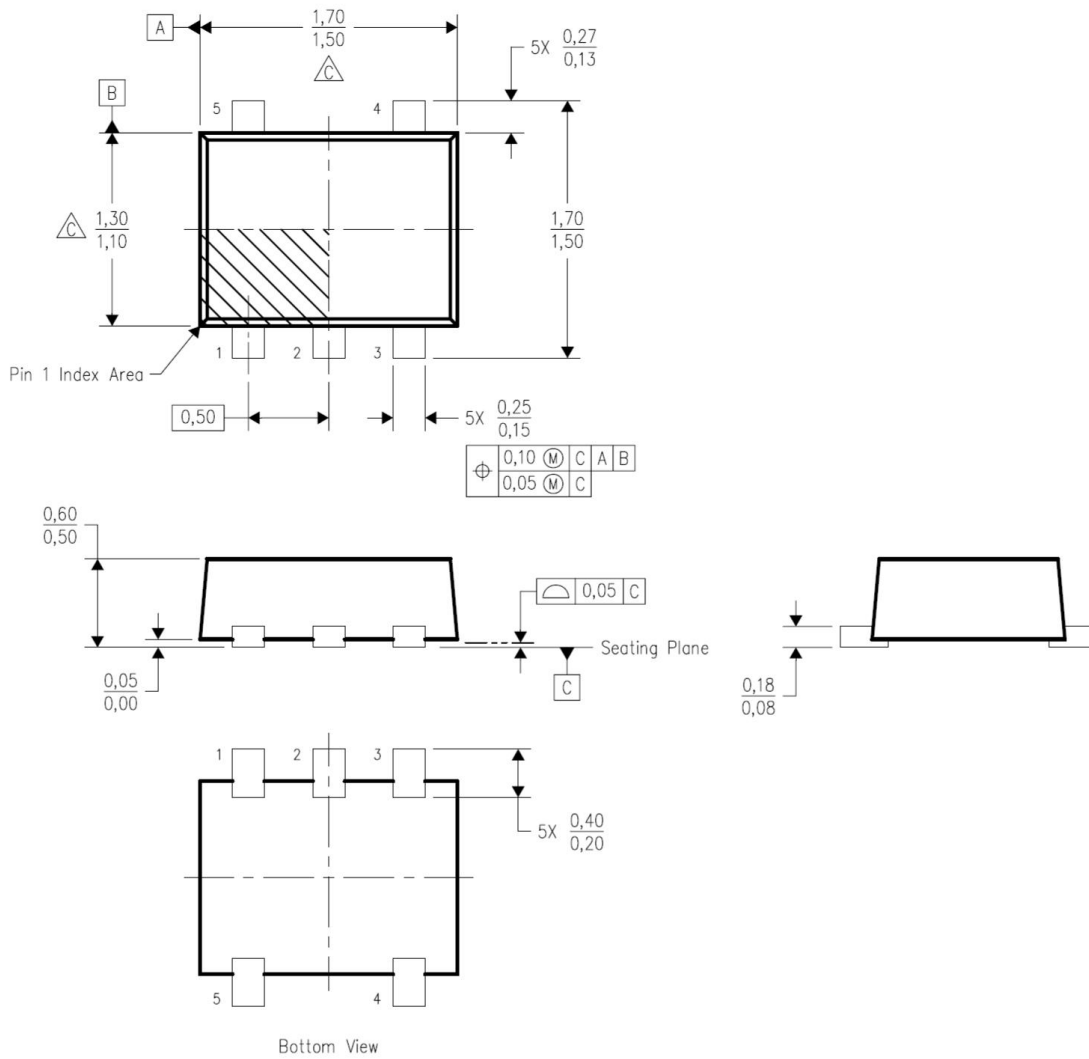

DRY (SOT-886)

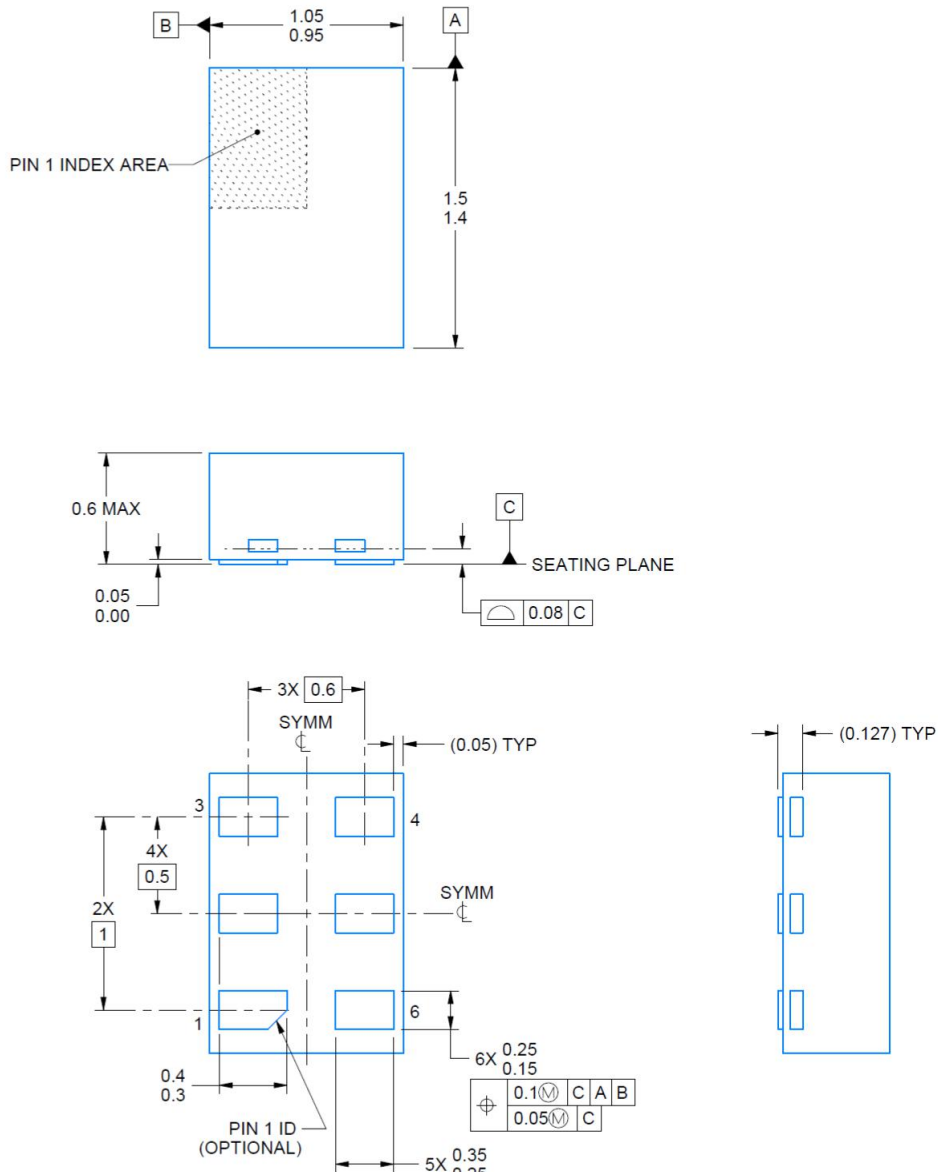

DSF (SON-6)

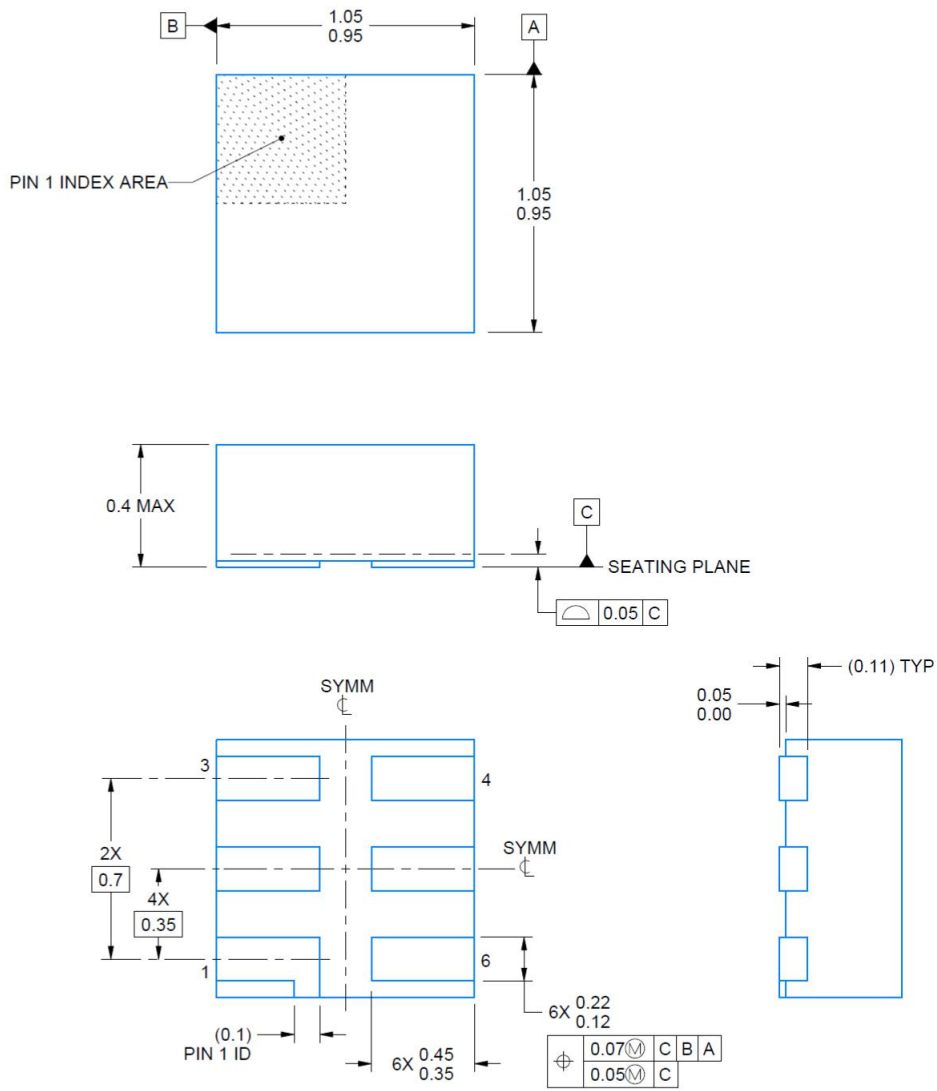

YZP (DSBGA-5)

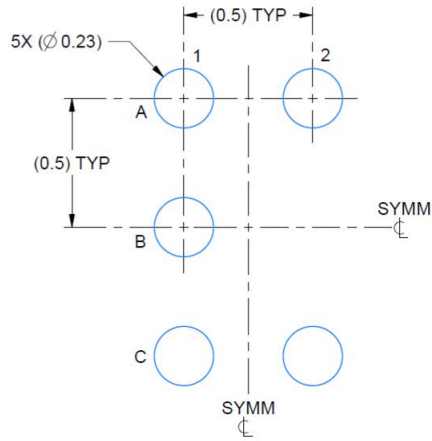

LAND PATTERN EXAMPLE
SCALE:40X

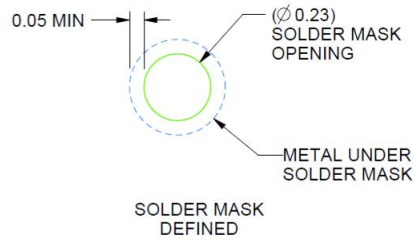
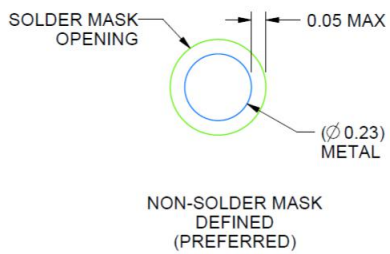

DPW (X2SON-5)

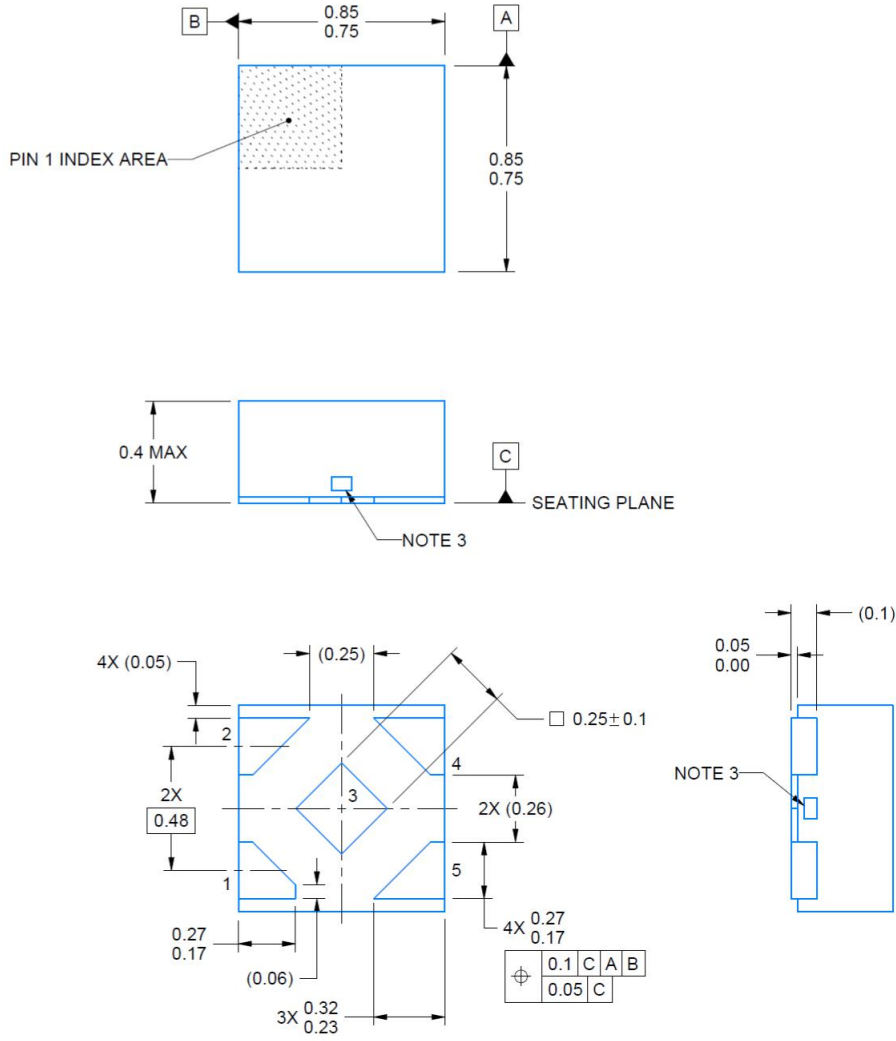

X-ON Electronics

Largest Supplier of Electrical and Electronic Components

Click to view similar products for [Inverters](#) category:

Click to view products by [TWGMC](#) manufacturer:

Other Similar products are found below :

[E5-652Z](#) [NLX2G04BMX1TCG](#) [CD4009UBE](#) [TC4584BFN](#) [NL17SG14AMUTCG](#) [NLU2GU04BMX1TCG](#) [NLV17SZ14DFT2G](#)
[TC74VHC04FK\(EL,K\)](#) [NLV74HC04ADTR2G](#) [NLU1G04AMUTCG](#) [NLX2G04CMUTCG](#) [NLX2G04AMUTCG](#) [NLV27WZ04DFT1G](#)
[NLU1GT14AMUTCG](#) [NLU1G04CMUTCG](#) [NL17SZU04P5T5G](#) [74LVC06ADTR2G](#) [74LVC04ADR2G](#) [NLV37WZ04USG](#)
[NLX3G14FMUTCG](#) [NL17SZ04P5T5G](#) [NLV17SG14DFT2G](#) [MC14069UBD](#) [NLU3G14CMX1TCG](#) [NLX2G14BMX1TCG](#)
[NLX2GU04AMX1TCG](#) [74HCT04DT](#) [74HCT14DT](#) [74HC14MT/TR](#) [74LVC1G14M5/TR](#) [74LVC1G04M5/TR](#) [74HC04-HXY](#) [74HC14](#)
[74LCX14FT\(AJ\)](#) [SN74LVC1G14DBVR](#) [SN74LVC1G04DBVR](#) [SN74LVC2G04DCKR\(UMW\)](#) [SN74LVC2G04DBVR](#)
[SN74LVC1G04DCKR](#) [SN74LVC2G14DBVR](#) [SN74LVC2G14DCKR\(UMW\)](#) [TC7S14F\(TE85L,F\)](#) [MM74HC14MTCX](#) [74VHC14MX](#)
[BU4069UBF-E2](#) [EMPP008Z](#) [NC7WZ14P6X](#) [NL27WZU04DTT1G](#) [NLU3G14MUTAG](#) [NLV74AC14DTR2G](#)