

Darlington array power drive integrated circuit

General Description

The ULN2003A is a high voltage, high current Darlington display made up of seven NPN Darlington tubes. All units share the emitter, and each unit uses an open collector for output. Each pair of Darlington is connected by a 2.7K base resistor, which is directly compatible with TTL and 5V CMOS circuits and can directly process data that previously required standard logic buffers. ULN2003A has high working voltage and large working current, the irrigation current can reach 500mA, and it can withstand 50V voltage in the off state. The output can also run in parallel under high load current, providing a good solution that requires multi-interface drive circuit.

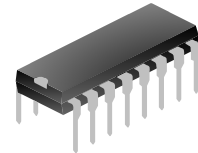

DIP-16-300-2.54

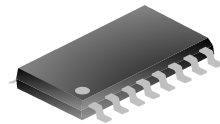

SOP-16-225-1.27

Features

- Wide operating voltage range
- Seven-way high-gain Darlington array
- High output voltage (up to 50V)
- High output current (up to 500mA)
- It can be directly connected with TTL, CMOS and PMOS
- Built-in clamp diode for sensitive load.

Applications

- Relay drive
- Dc lighting drive
- Stepper motor drive
- Solenoid valve
- Dc brushless motor drive

Block Diagram

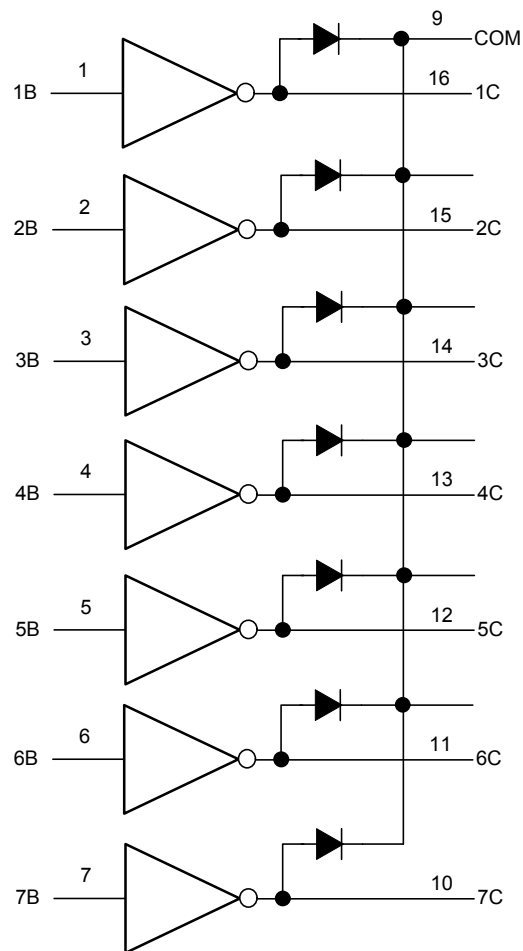

MAXIMUM RATINGS(Ta=25°C unless otherwise noted)

Parameter	Symbol	Value	Unit
Input voltage	V _{IN}	-0.5~30	V
Output voltage	V _{OUT}	-0.5~50	V
Clamp diode reverse voltage	V _R	50	V
Collector continuous working current	I _{OUT}	500	mA
Clamp diode forward	I _F	500	mA
Temperature of storage	T _{STG}	-55~150	°C
Operating temperature	T _{OPR}	-40~85	°C
Junction temperature	T _J	-40~150	°C

ELECTRICAL CHARACTERISTICS (Ta=25°C unless otherwise specified)

Parameter	Symbol	Test conditions	MIN	TPE	MAX	Unit
Output tube leakage current	I _{CEX}	T _A =25°C, V _{CE} =50V(figure 1)			20	uA
		T _A =85°C, V _{CE} =50V(figure 1)			100	
CE saturation pressure voltage	V _{CE(sat)}	I _{OUT} =350mA, I _{IN} =500 uA(figure 3)		1.3	1.6	V
		I _{OUT} =250mA, I _{IN} =350 uA(figure 3)		1.1	1.3	
		I _{OUT} =100mA, I _{IN} =250 uA(figure 3)		0.9	1.1	
Open state current	I _{I(ON)}	V _I =3.85V(figure 4)		0.93	1.35	mA
Off input current	I _{I(OFF)}	I _C =500uA(figure 5)	50	100		uA
		T _A =+25°C	50	100		
		T _A =+85°C	25	50		
Open state input voltage	V _{I(ON)}	V _{CE} =2.0V, I _C =200mA(figure 6)			2.4	V
		V _{CE} =2.0V, I _C =250mA(figure 6)			2.7	
		V _{CE} =2.0V, I _C =300mA(figure 6)			3.0	
Input capacitance	C _I			15	30	pF
Conduction delay time	t _{MH}	0.5V _I to 0.5 V _O			1.0	μS
Turn off the delay time	t _{ML}	0.5V _I to 0.5 V _O			1.0	
Leakage current	I _R	V _R =50V(figure 7)				μA
		T _A =+25°C		5	10	
		T _A =+85°C		10	50	
Forward voltage	V _F	I _F =350mA(figure 8)		1.7	2.0	V

Note :

1. The limit value refers to the possibility that the device may be damaged beyond the range, which is not the range of normal working conditions of the device. The electrical parameter table provides a range of operating conditions for the device;
2. Unless otherwise specified, all conditions apply to the Darlington array .
3. Under normal conditions, the continuous working current is 350mA when the pulse width is 20ms at 70° C and V_{CE} (Sat)= 1.6V for each output.

Typical Characteristics Curves

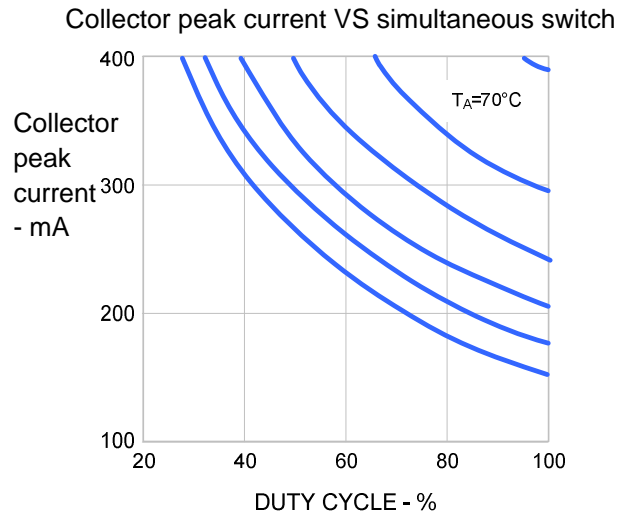
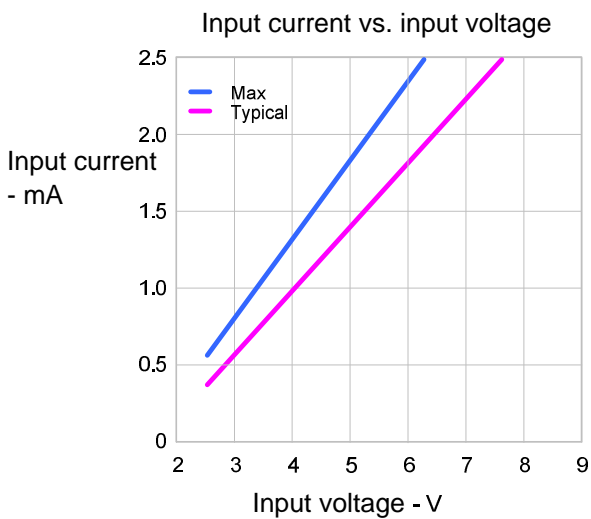
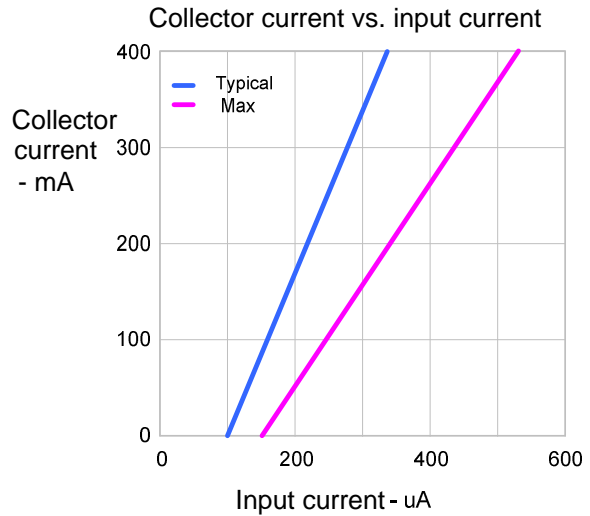
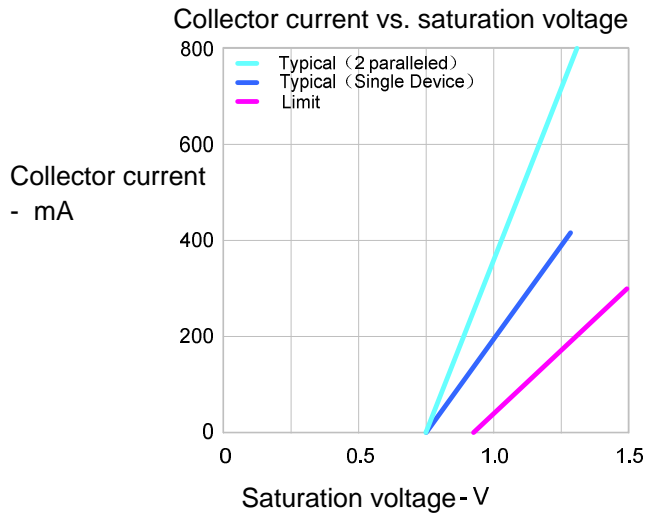

Internal equivalent circuit diagram

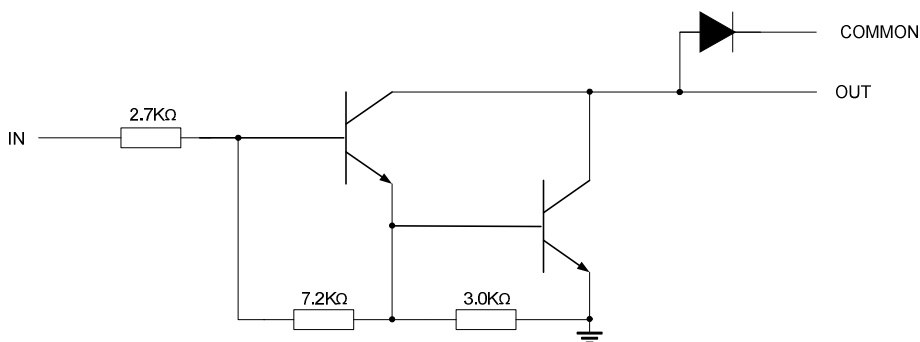

Test circuit diagram

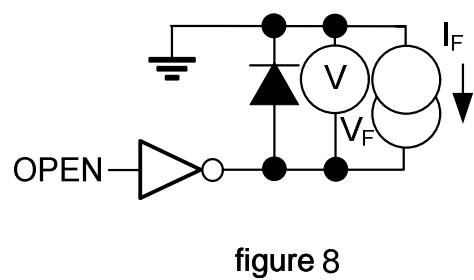
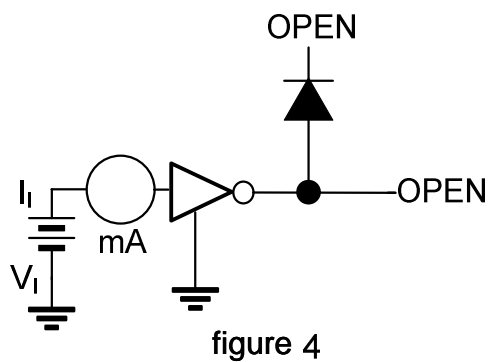
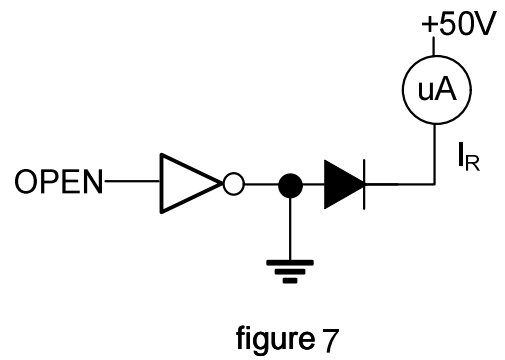
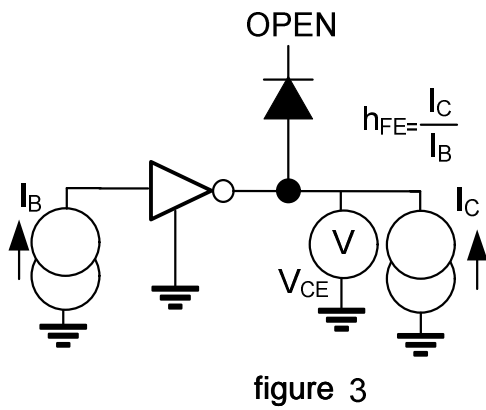
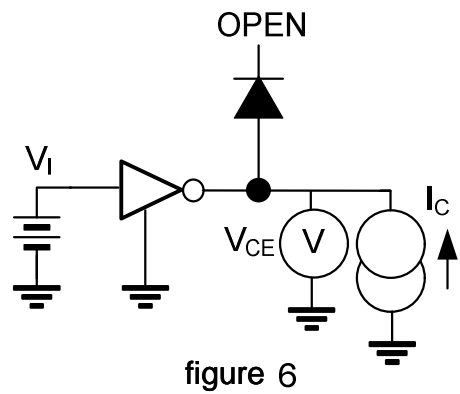
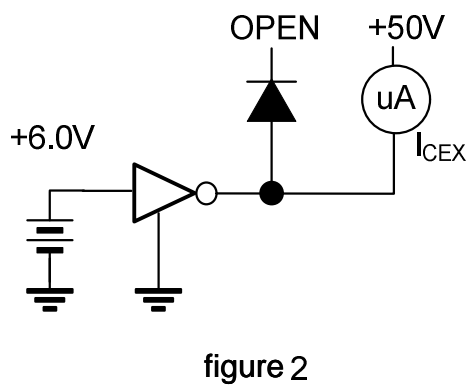
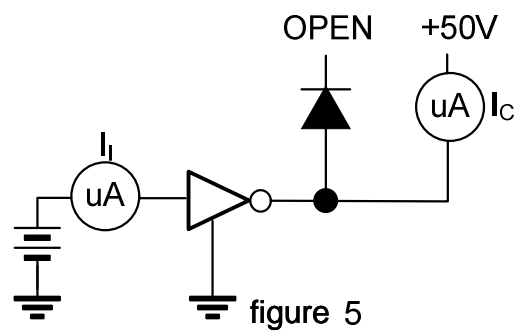
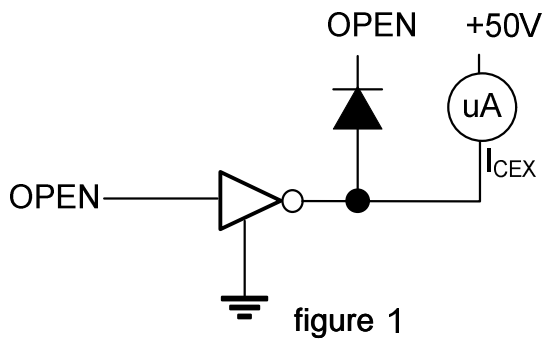

Package Outline

DIP-16-300-2.54

UNIT : MM

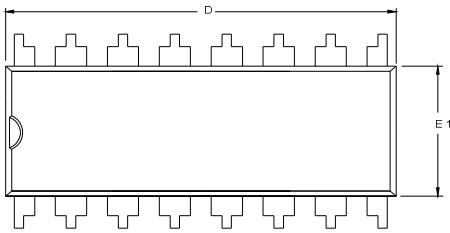
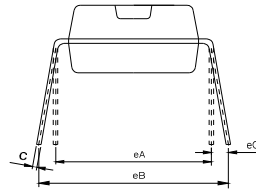
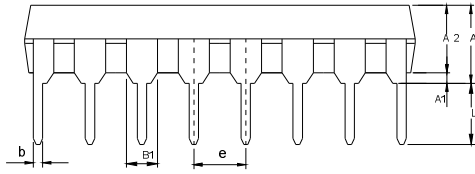

SYMBOL	MILLIMETER		
	MIN	NOM	MAX
A	—	—	4.45
A1	0.50	—	—
A2	3.20	—	3.70
b	0.38	0.46	0.54
B1	1.52BSC		
c	0.20	—	0.35
D	18.90	—	19.45
E1	6.15	—	6.60
e	2.54BSC		
eA	7.62BSC		
eB	7.62	—	9.30
eC	0	—	1.52
L	3.00	—	—

SOP-16-225-1.27

UNIT : MM

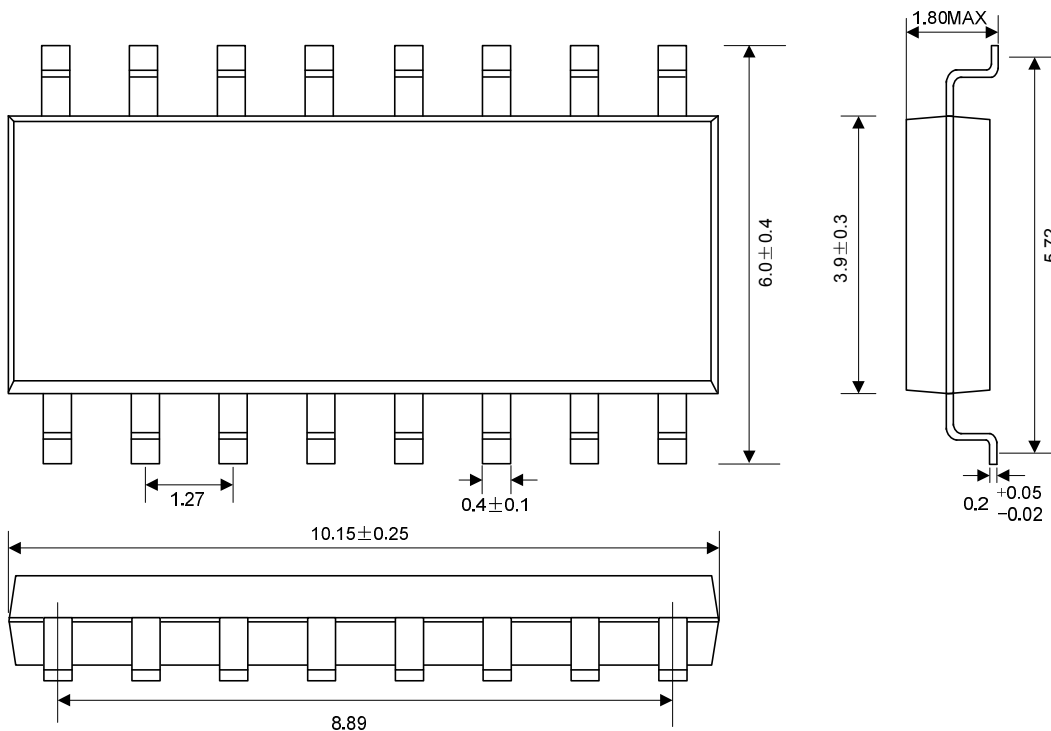

X-ON Electronics

Largest Supplier of Electrical and Electronic Components

Click to view similar products for [Darlington Transistors](#) category:

Click to view products by [TWGMC](#) manufacturer:

Other Similar products are found below :

[281287X](#) [BDV64B](#) [SBSP52T1G](#) [Jantx2N6058](#) [LB1205-L-E](#) [2N6053](#) [MPSA63](#) [2N6667](#) [NTE256](#) [TIP120](#) [MJ11028](#) [TIP140](#) [Jantx2N6352](#)
[TIP127L-BP](#) [2N6383](#) [ULN2803](#) [ULN2003ALM/TR](#) [ULN2803ADM/TR](#) [HT62783ARWZ](#) [ULN2803](#) [ULN2003A](#) [ULN2003](#)
[SSTA28MGT116](#) [TM2803L](#) [Aip2003SA16.TR](#) [SAP2003SCTR](#) [AiP2003LSA.TR](#) [BCV27](#) [MMBTA14](#) [MMBTA14](#) [ULN2803](#) [2SB1560](#)
[2SB852KT146B](#) [2SD2560](#) [TIP112TU](#) [BCV27](#) [MMBTA13-TP](#) [MMBTA14-TP](#) [MMSTA28T146](#) [BSP50H6327XTSA1](#) [NTE2557](#)
[NJVNJD35N04T4G](#) [CP527-2N6299-CT5](#) [CP127-2N6301-CT5](#) [MPSA29-D26Z](#) [FJB102TM](#) [FMMT38C](#) [BCV29](#) [BCV47](#) [FMMT734](#)