

General Description

The XC6206P Series are highly precise, low power consumption, 3 terminal, positive voltage regulators manufactured using CMOS technologies

The XC6206P Series consists of a current limiter circuit, a driver transistor, a precision reference voltage and an error correction circuit. The series is compatible with low ESR ceramic capacitors. The current limiter's foldback circuit operates as a short circuit protection as well as the output current limiter for the output pin.

Features

- Quiescent Current: 8 μ A
- Input Voltage Range: Max.6V
- Output Current: 300mA
- Low Dropout Voltage: 290mV@100mA (VOUT=3.3V)
- Output Voltage: 1.2~5.0V
- Output Voltage Accuracy: $\pm 2\%$ (Typ.)
- Low Power Consumption

Applications

- Mobile Phones
- Battery powered equipment
- Portable game consoles
- Reference voltage sources

Ordering Information

XC6206P-	□□□□	
		Package Type
		MR : SOT-23
		PR : SOT-89
		Output Voltage Accuracy:
		1 : $\pm 1\%$
		2 : $\pm 2\%$
		Output Voltage
		12 : 1.2V 15 : 1.5V 18 : 1.8V
		25 : 2.5V 28 : 2.8V 30 : 3.0V
		33 : 3.3V 50 : 5.0V

SOT-23

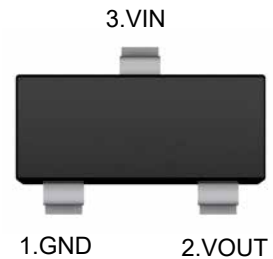

SOT-89

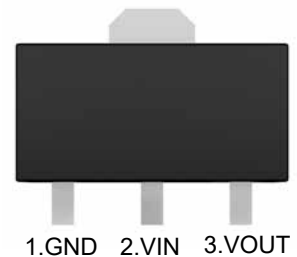

Block Diagram

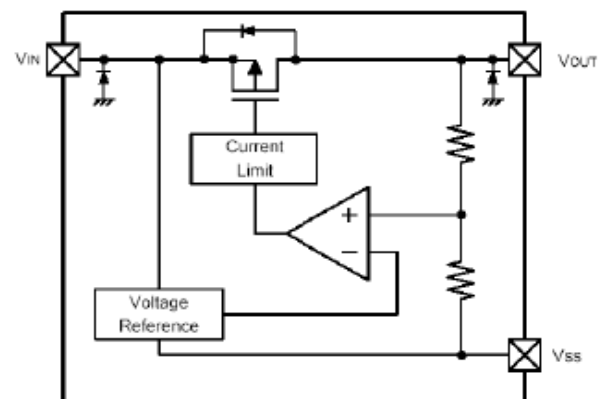

Absolute Maximum Ratings ^{Note1}

Ratings at 25°C ambient temperature unless otherwise specified.

Parameter	Symbol	Value	Unit
Input Voltage	V_{IN}	-0.3 ~ +6	V
Output Voltage	V_{OUT}	-0.3 ~ ($V_{IN}+0.3$)	V
Output Current	I_{OUT}	300	mA
Power Dissipation	SOT-23	200	mW
	SOT-23-3	250	mW
	SOT-89	500	mW
Operating Temperature Range	T_{opr}	-20 ~ 85	°C
Storage Temperature Range	T_{stg}	-55 ~ 125	°C

Typical Application Circuit

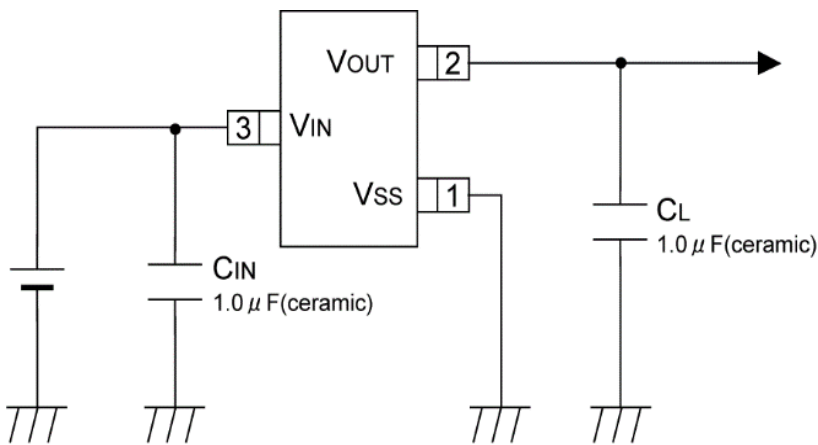

Electrical Characteristics

($V_{IN}=V_{OUT}+1$, $C_{IN}=C_{OUT}=1\mu F$, $T_A=25^\circ C$, unless otherwise noted.)

Parameter	Symbol	Conditions	MIN.	TYP.	MAX.	Unit
Input Voltage	V_{IN}				6	V
Output Voltage Accuracy	ΔV_{OUT}	$I_{OUT}=30mA$	-2		+2	%
Quiescent Current	I_Q	$I_{OUT}=0mA$		8	15	μA
Dropout Voltage	V_{DROP}	$I_{OUT}=100mA, V_{OUT}\leq 1.5V$			570	mV
		$I_{OUT}=100mA, 1.8V\leq V_{OUT}\leq 2.5V$			420	
		$I_{OUT}=100mA, 2.8V\leq V_{OUT}\leq 5V$			350	
Line Regulation	ΔV_{LINE}	$V_{IN}=V_{OUT}+1$ to 6V $I_{OUT}=40mA$			0.2	%/V
Load Regulation	ΔV_{LOAD}	$1mA < I_{OUT} < 80mA$		12	30	mV
Output Voltage Temperature Coefficient	$TC_{V_{OUT}}$	$I_{OUT}=30mA$, $T_A=0\sim 70^\circ C$		± 100		ppm/ $^\circ C$
PSRR	f=1KHz	PSRR		-70		dB
Output Noise	E_{NO}	BW=10Hz~100KHz		160		μV_{RMS}

Typical Characteristics Curves

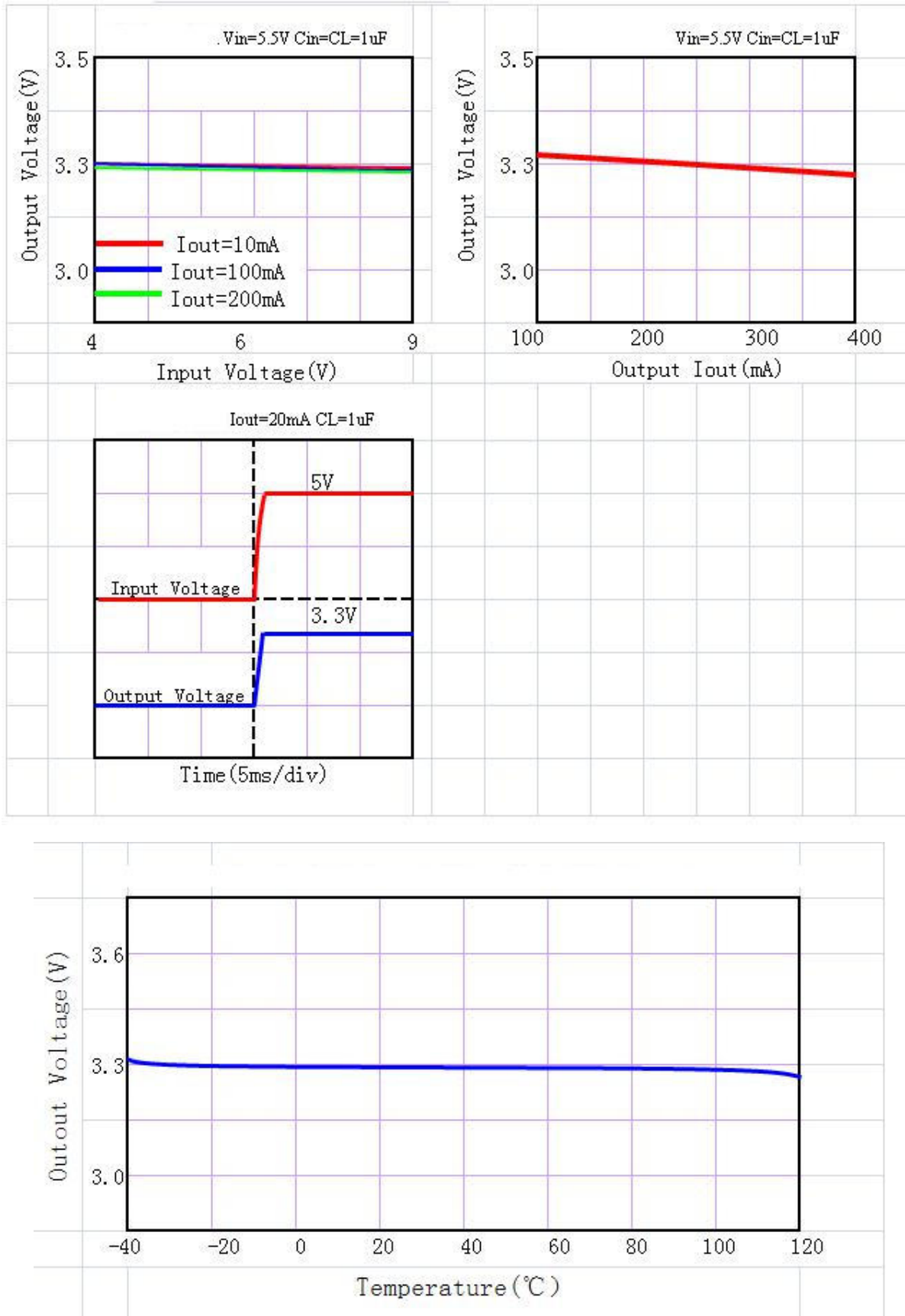

Package Outline

SOT-23

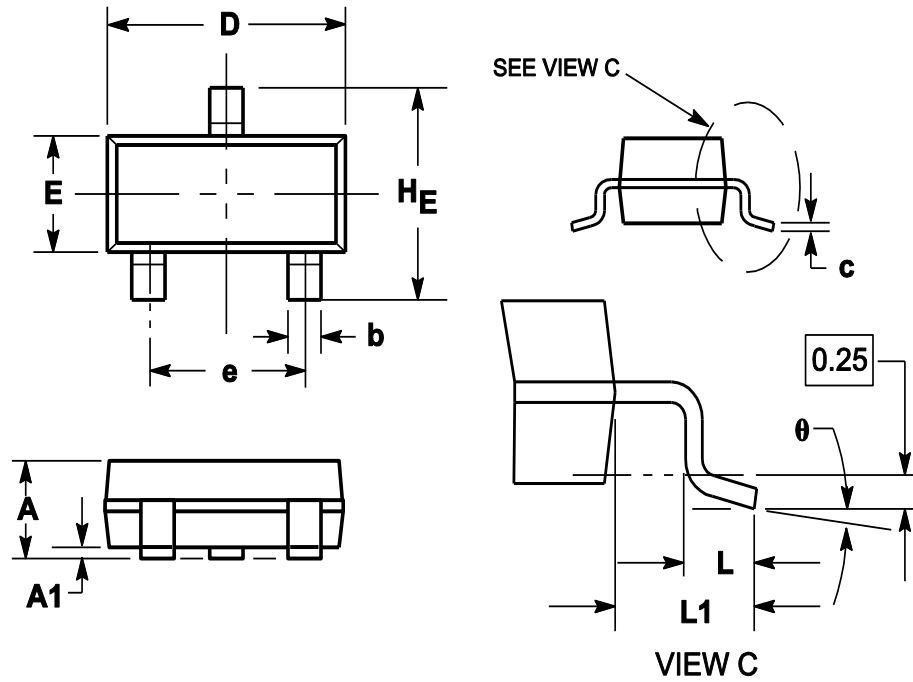

Symbol	Dimensions in millimeter		
	Min.	Typ.	Max.
A	0.900	1.025	1.150
A1	0.000	0.050	0.100
b	0.300	0.400	0.500
c	0.080	0.115	0.150
D	2.800	2.900	3.000
E	1.200	1.300	1.400
HE	2.250	2.400	2.550
e	1.800	1.900	2.000
L1	0.550REF		
L	0.300		0.500
θ	0°		8°

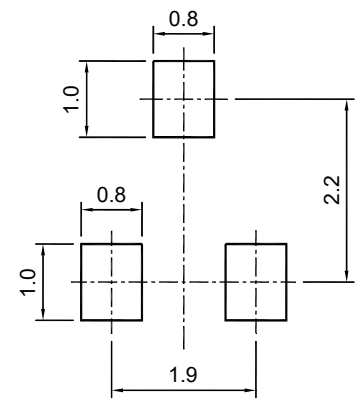

SOT-23

Recommended soldering pad

Package Outline

SOT-89

Dimensions in mm

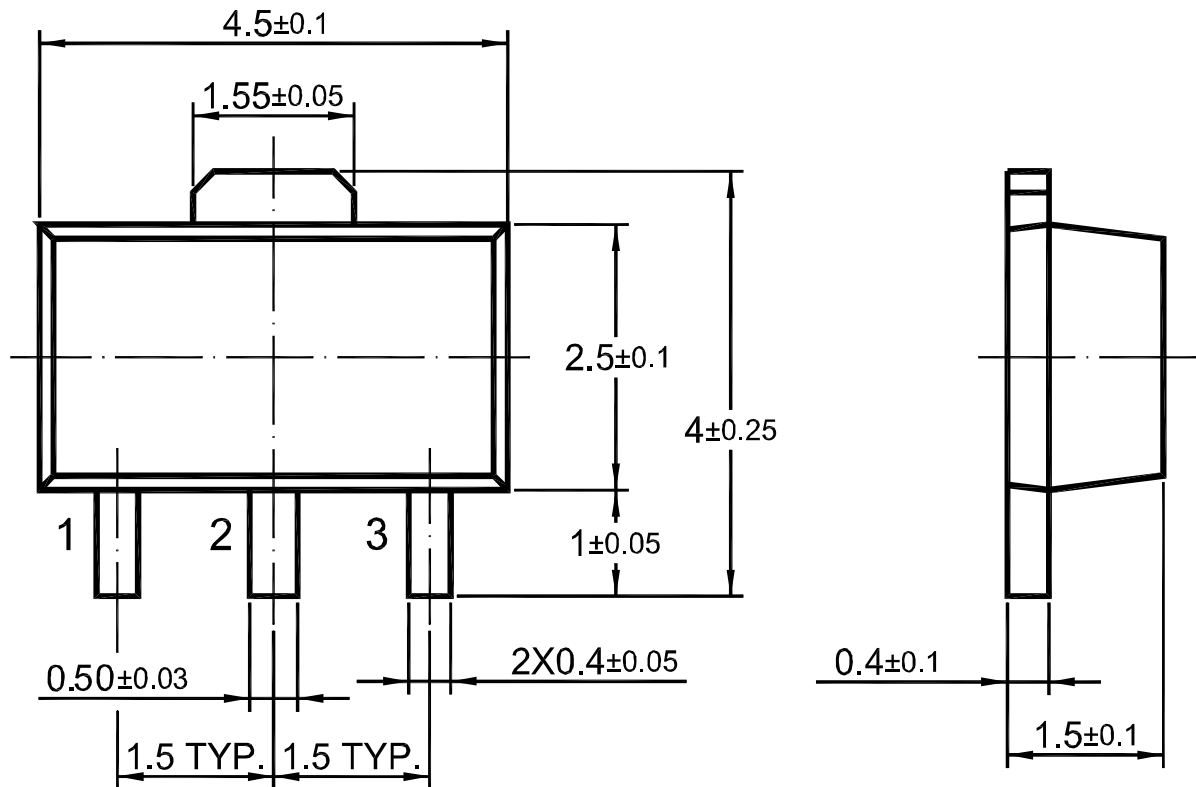

X-ON Electronics

Largest Supplier of Electrical and Electronic Components

Click to view similar products for [Linear Voltage Regulators](#) category:

Click to view products by [TWGMC](#) manufacturer:

Other Similar products are found below :

[LV56831P-E](#) [LV5684PVD-XH](#) [MCDTSA6-2R](#) [L7815ACV-DG](#) [PQ3DZ53U](#) [LV56801P-E](#) [L78L05CZ/1SX](#) [L78LR05DL-MA-E](#) [636416C](#)
[714954EB](#) [LV5680P-E](#) [L78M15CV-DG](#) [L79M05T-E](#) [MIC5283-5.0YML-T5](#) [TLS202A1MBVHTSA1](#) [L78LR05D-MA-E](#) [NCV317MBTG](#)
[NTE7227](#) [MP2018GZD-33-P](#) [MP2018GZD-5-P](#) [LV5680NPVC-XH](#) [LT1054CN8](#) [MP2018GZD-5-Z](#) [MP2018GZD-33-Z](#) [AT55EL50ESE](#)
[APL5934DKAI-TRG](#) [CL9193A15L5M](#) [CL9036A30F4M](#) [CL9036A18F4M](#) [CL9036A25F4M](#) [CL9036A28F4M](#) [CL9036A33F4M](#)
[CL9906A18F4N](#) [CL9906A30F4N](#) [CL9908A30F4M](#) [CL9908A33F4M](#) [CL9908A18F4M](#) [CL9908A28F4M](#) [TL431ACM/TR](#) [TL431AIM/TR](#)
[LM78L05ACM/TR](#) [HT7812ARMZ](#) [HT7805ARMZ](#) [HXY6206I-3.0](#) [HXY6206I-3.3](#) [XC6206P252MR](#) [XC6206P282MR](#) [XC6206P302MR](#)
[XC6206P332MR](#) [CJ6211B12F](#)