

SPECIFICATION FOR APPROVAL

CUSTOMER : _____

PRODUCT TYPE : SMD TCXO 2.5 * 2.0

NOMINAL FREQ. : 16.368 MHz

TXC P/N : 7L16300006

REVISION : A1

CUSTOMER P/N : _____

PM / SALES : _____

DATE : _____

CUSTOMER SIGNATURE & DATE
: _____

- (1) TXC requires one copy returned with signature and title of authorized individual that signifies acceptance of the attached specifications.
- (2) Orders received and accepted by TXC after return of signed copy of specification will be produced per these specifications.
- (3) Any changes to these specifications must be agreed upon by both parties and new revision of the Product Specification Sheet will be issued.
- (4) Any issuance of purchase order prior to consigning back the Approval page of "Specification Sheets" from customers will be regarded as the agreement on the contents of these specifications.

Attachment: Product Specification Sheet

- 1
- 2
- 3
- 4
- 5

RoHS Compliant

PRODUCT SPECIFICATION SHEET

PRODUCT TYPE : SMD TCXO 2.5 * 2.0

NOMINAL FREQ. : 16.368 MHz

TXC P/N : 7L16300006

REVISION : A1

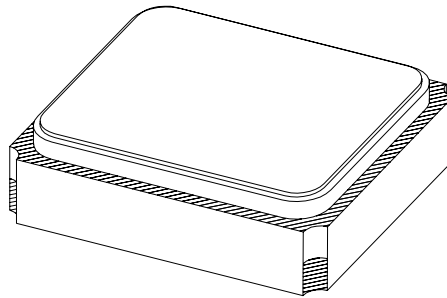

PE/RD	QA	MFG
<i>Kenneth Kao</i>	<i>Chester Kao</i>	<i>Hungta Liu</i>
<i>3/25/10</i>	<i>3/30/10</i>	<i>2010.3.30</i>

NOTE:

- (1) Lead Free Products are " Directive 2002/95/EC of The European Parliament of 27 January 2003 on the restriction of the use of certain hazardous substances (RoHS) in electrical and electronic equipment" Compliant (Attachment: SGS Test Report).
- (2) Revision "Sx" is for engineering samples only. PE/RD's approval required.
- (3) Revision "Ax" is production ready. PE, QA and MFG's approval required.

RoHS Compliant

ELECTRICAL SPECIFICATIONS

Item	Parameters		Condition	Electrical Specifications				Note
				MIN	TYP	MAX	UNITS	
1	Nominal Frequency			16.368000			MHz	
2	Operating Temperature Range			-30		85		
3	Supply Voltage			2.60	2.80	3.00	V	
4	Current Drain		With standard output load		1.5		mA	
5	Output Level			0.8			V	1
6	Output Type			Clipped Sinewave				
7	Standard Output Load			10 KΩ // 10 pF				
8	Frequency Tolerance After Reflow		Two reflow soldering			±2.0	ppm	
9	Frequency Stability	vs. Temperature	Referenced to: 25 ± 2			±0.5	ppm	
10		vs. Load	± 10% output load			±0.2	ppm	
11		vs. Supply Voltage	± 5% standard Vcc			±0.2	ppm	
12	Slope of Frequency Drift over Temperature					±0.1	ppm/	2
13	Storage Temperature			-40		85		
14	Start-up Time	vs. Frequency	Within ± 1 ppm			2.5	ms	
15		vs. Output Level	To 90% of Vp-p			2.5	ms	
16	Duty Cycle			40	50	60	%	
17	Aging over 1st Year					±1.0	ppm	
18	Harmonics					-7	dBc	
19	Phase Noise	@ 10 Hz offset	25 ± 5			-70	dBc/Hz	
20		@ 100 Hz offset				-105	dBc/Hz	
21		@ 1 kHz offset				-130	dBc/Hz	
22		@ 10 kHz offset				-145	dBc/Hz	

Note 1 : Decoupling capacitor is required in external circuit.

Note 2 : Minimum of 1 frequency reading every 2°C over temperature, based on temperature varied at maximum of 2°C per minute.

TESTING CIRCUIT

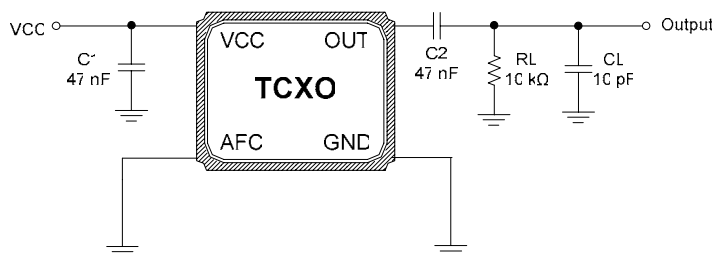

External Components

Name	Function
C1	AC Noise Bypass for VCC
C2	DC Block for Output
RL	Load Resistance
CL	Load Capacitance

Note: Bypass capacitor (C1) and DC blocking capacitor (C2) should be placed.

DIMENSIONS

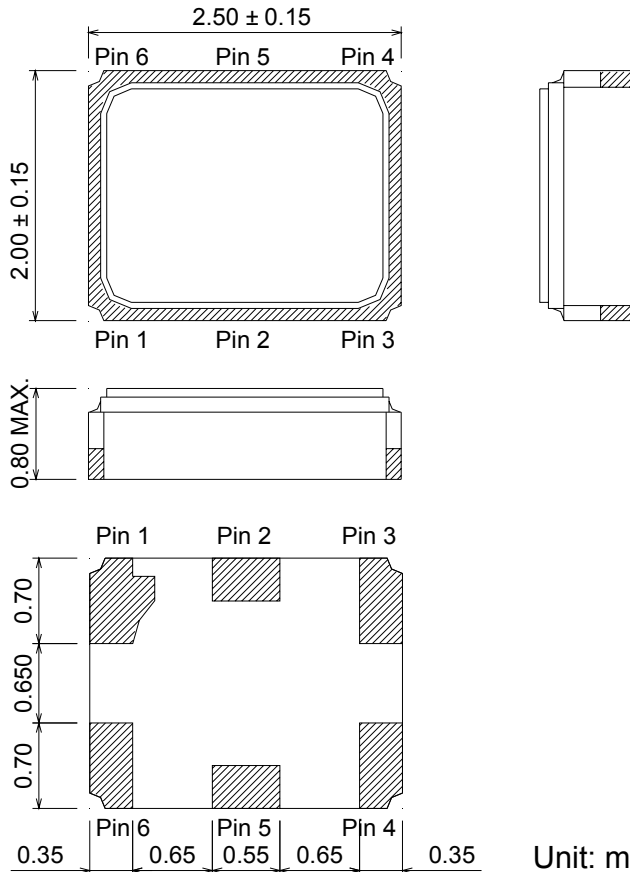

Unit: mm

Pin Function

Name	Function
Pin 1	GND
Pin 2	NC
Pin 3	GND
Pin 4	OUTPUT
Pin 5	NC
Pin 6	VCC

Land Pattern

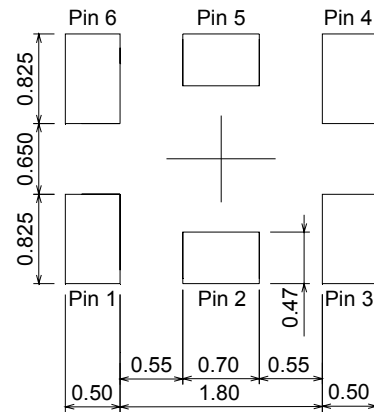

SUGGESTED REFLOW PROFILE

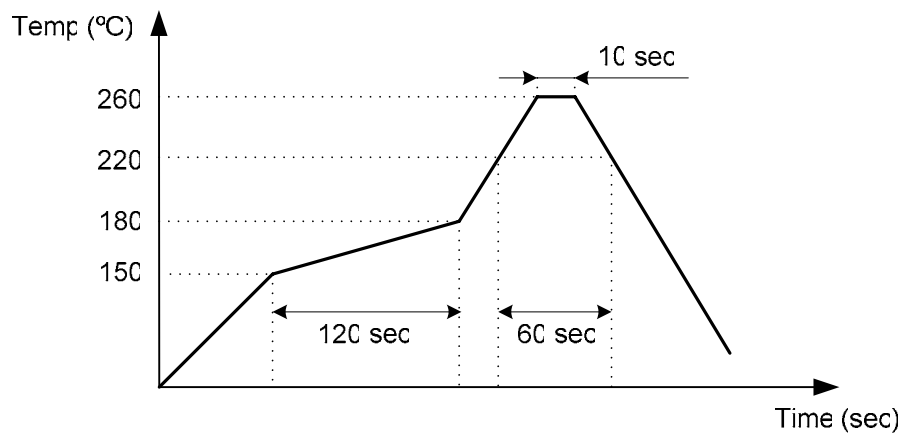

Note : Total Time: 200 sec. Max., Solder Melting Point: 220 $^{\circ}\text{C}$

MARKING

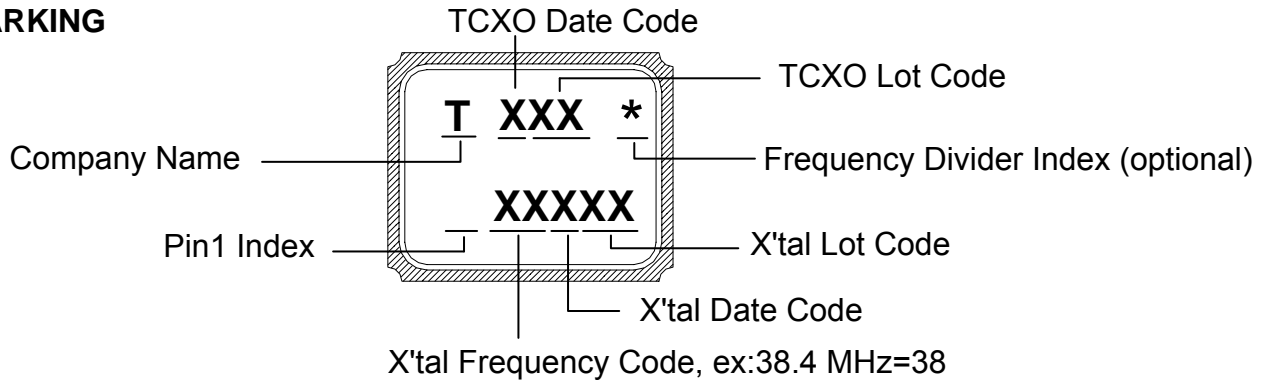

DATE CODE

				MONTH											
YEAR				JAN	FEB	MAR	APR	MAY	JUN	JUL	AUG	SEP	OCT	NOV	DEC
2005	2009	2013	2017	A	B	C	D	E	F	G	H	J	K	L	M
2006	2010	2014	2018	N	P	Q	R	S	T	U	V	W	X	Y	Z
2007	2011	2015	2019	a	b	c	d	e	f	g	h	j	k	l	m
2008	2012	2016	2020	n	p	q	r	s	t	u	v	w	x	y	z

* This date code will be cycled every four years.

Note: If TCXO frequency is X'tal frequency divided by 2, then frequency divider index appears.
 If TCXO frequency is the same as X'tal frequency, then no frequency divider index appears.

PACKING : (EIA-481-2)

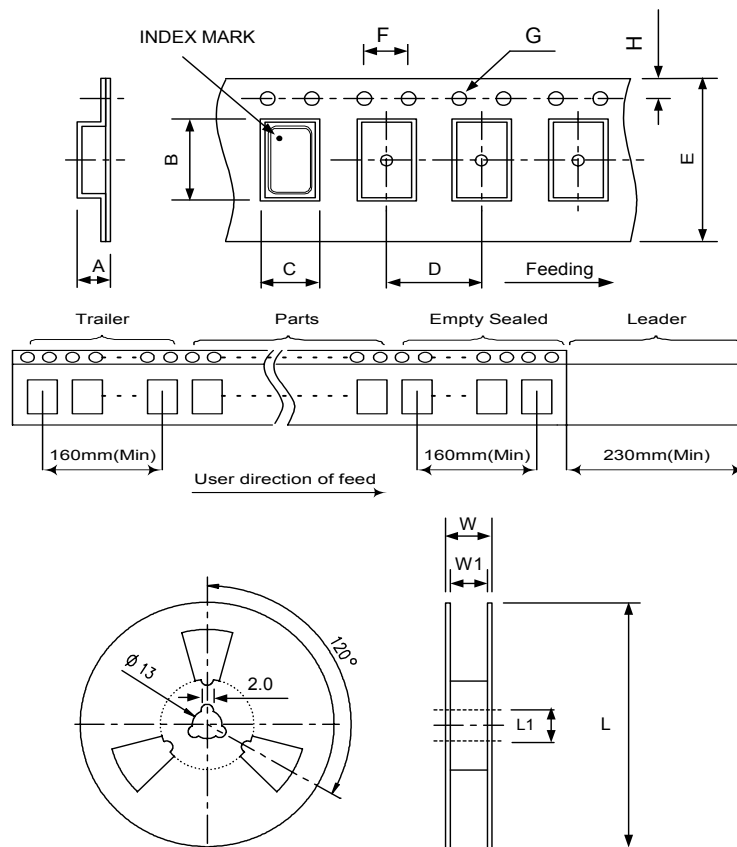

Unit: mm

DIMENSIONS (mm)	A	B	C	D	E	F	G	H	L	L1	W	W1	Standard Reel Quantity is 3,000 pcs per reel
	1.15	2.70	2.25	4.00	8.00	4.00	1.55	1.75	178	13.0	11.6	8.4	

WEIGHT

0.0135 g / piece(TYP), 40 ± 2 g /3 kpcs(regardless of tape weight)

STRUCTURE ILLUSTRATION

Crystal Enclosure Seal: Seam Welding

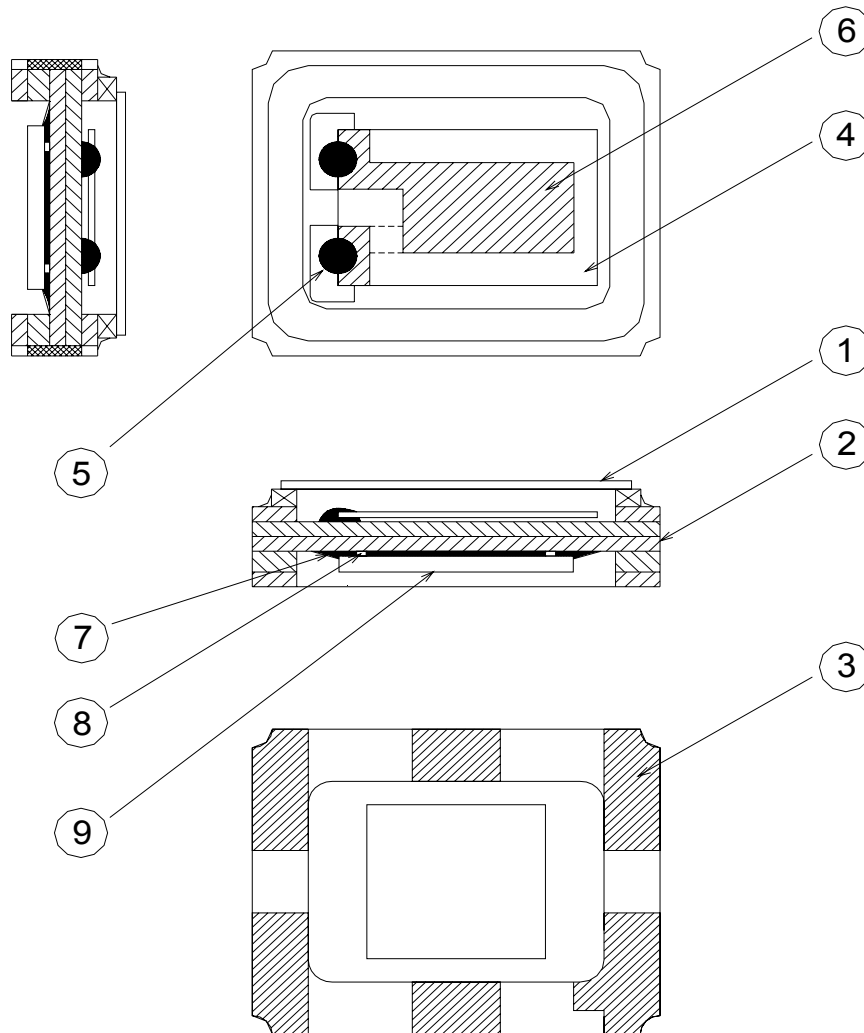

No.	COMPONENTS	MATERIALS	FINISH/SPECIFICATIONS
1	Cap	Metal(Fe + Co + Ni)	-
2	Base	Ceramic	Color Black
3	Pad	Au	Tungsten Metalize + Ni Plating + Au Plating
4	Crystal Blank	SiO ₂	-
5	Conductive Adhesive	Ag	Silicone Resin
6	Electrode	Noble Metal	-
7	Underfill	Organic	Color Black
8	Bump	Au	
9	IC	Si	

RELIABILITY SPECIFICATIONS

1. Mechanical Endurance

No.	Test Item	Test Methods	Criteria
1.1	Drop Test	Height : 100 cm height Direction : X,Y,Z 6 directions Test cycles : 3 cycles Fall freely on to concrete floor Mounting on test fixture (total weight=100 g)	+/- 2.0 ppm
1.2	Mechanical Shock	Acceleration : 1000 g Duration : 0.5 ms Test cycles : 3 times for all 3 directions	+/- 2.0 ppm
1.3	Vibration	Frequency range : 10 ~ 2000 Hz Amplitude : 1.52 mm (10 ~ 80 Hz) Acceleration : 20 g (80 ~ 2000 Hz) Sweep speed : 20 minutes/cycle Direction : X,Y,Z 3 directions Duration : 4 hours/each direction	+/- 2.0 ppm
1.4	Gross Leak	Standard sample for automatic gross leak detector. Test Pressure : 2 kg/cm ²	< 1.5 × 10 ⁻⁵ Pa m ³ / sec
1.5	Fine Leak	Helium bombing 4.5 kgf/cm ² for 2 hours	< 1.0 × 10 ⁻⁹ Pa m ³ / sec
1.6	Solderability	Preheate temperature : 125 ± 5 Preheate time : 120 sec Soldering temperature : 245 ± 5 Duration : 5 ± 1 sec Method : Solder bath method	90% Coated

[Note] Criteria mean the maximum frequency change after reliability test, frequency shall be measured at 25 .

2. Environmental Endurance

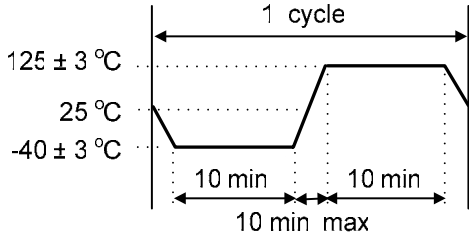
No.	Test Item	Test Methods	Criteria
2.1	High Temp. Storage	Temperature : +125 ± 3 Duration : 168 hours	+/- 2.0 ppm
2.2	Low Temp. Storage	Temperature : -40 ± 3 Duration : 500 hours	+/- 2.0 ppm
2.3	Thermal Shock (Air to Air)	Total 100 cycles of the following temperature cycle : 	+/- 2.0 ppm
2.4	High Temp & Humidity	Temperature : 85 ± 3 Humidity: RH 85% Duration : 168 hours	+/- 2.0 ppm
2.5	Aging	Temperature : 85 ± 3 Duration : 500 hours Voltage input by specification	+/- 2.0 ppm

[Note] Criteria mean the maximum frequency change after reliability test, frequency shall be measured after 2 hours at 25 leaving.

PRODUCT TYPE : SMD TCXO 2.5 * 2.0

P/N : 7L16300006

REVISION : A1

NOTICE

1. Product storage (Before dry bag opened) and usage(After dry bag opened) condition :

	Before dry bag opened	After dry bag opened
Temperature	-10 ~ 50	-10 ~ 30
Humidity	10% ~ 65%	10% ~ 60%
Period	6 months	2 days

2. Please keep product used within 2 days after dry bag opened, and pack the rest product into dry bag by heat sealing the bag neck.

PROHIBITED ITEMS

Be sure to use the product under the following conditions. Otherwise, the product may lose function due to improper usage.

1. Reflow soldering heat resistance

- 1.1 Peak temperature and period : 265 , 10 sec.
- 1.2 Preheating temperature and period : 170 ± 10 , 120 sec.
- 1.3 Reflow passage times : twice

2. Manual soldering heat resistance

- 2.1 Soldering iron :

Pressing a soldering iron of 350 on the terminal electrode below 3 sec.

- 2.2 Hot air gun soldering :

Keep the hot air export head above the product with a minimum gap distance : 1.5 cm

Maximum hot air blowing temperature : 300

Maximum hot air blowing period : 2 sec

X-ON Electronics

Largest Supplier of Electrical and Electronic Components

Click to view similar products for [Standard Clock Oscillators](#) category:

Click to view products by [TXC Corporation](#) manufacturer:

Other Similar products are found below :

[EP1400SJTSC-125.000M](#) [601137](#) [601252](#) [CSX750FBC-24.000M-UT](#) [CSX750FBC-33.333M-UT](#) [CSX750FCC-3.6864M-UT](#) [F335-12](#) [F335-25](#) [F535L-50](#) [DSC506-03FM2](#) [ASA-20.000MHZ-L-T](#) [ASA-25.000MHZ-L-T](#) [ASA-27.000MHZ-L-T](#) [ASV-20.000MHZ-LR-T](#) [ECS-2018-160-BN-TR](#) [EL13C7-H2F-125.00M](#) [MXO45HS-2C-66.6666MHZ](#) [NBXDBB017LN1TAG](#) [NBXHBA019LN1TAG](#) [SiT1602BI-22-33E-50.000000E](#) [SIT8003AC-11-33S-2.04800X](#) [SiT8256AC-23-33E-156.250000X](#) [SIT8918AA-11-33S-50.000000G](#) [SM4420TEV-40.0M-T1K](#) [SMA4306-TL-H](#) [F335-24](#) [F335-40](#) [F335-50](#) [F535L-10](#) [F535L-12](#) [F535L-16](#) [F535L-24](#) [F535L-27](#) [F535L-48](#) [CSX750FBC-20.000M-UT](#) [CSX-750FBC33333000T](#) [CSX750FBC-4.000M-UT](#) [CSX750FBC-7.3728M-UT](#) [CSX750FBC-8.000M-UT](#) [CSX-750FCC14745600T](#) [CSX750FCC-16.000M-UT](#) [CSX-750FCC40000000T](#) [CSX750FCC-4.000M-UT](#) [ASA-22.000MHZ-L-T](#) [ASA2-26.000MHZ-L-T](#) [ASA-40.000MHZ-L-T](#) [ASA-48.000MHZ-L-T](#) [ASA-60.000MHZ-L-T](#) [ASF1-3.686MHZ-N-K-S](#) [XLH735025.000JU4I8](#)