

SPECIFICATION FOR APPROVAL

CUSTOMER : _____

PRODUCT TYPE : SMD SEAM SEALING X'TAL 3.2x2.5

NOMINAL FREQ. : 20.736000MHz

TXC P/N : 7M20700003

REVISION : A1

CUSTOMER P/N : _____

PM / SALES : _____

DATE : _____

CUSTOMER SIGNATURE & Date _____

- (1) TXC requires one copy returned with signature and title of authorized individual that signifies acceptance of the attached specifications.
- (2) Orders received and accepted by TXC after return of signed copy of specification will be produced per these specifications.
- (3) Any changes to these specifications must be agreed upon by both parties and new revision of the Product Specification Sheet will be issued.
- (4) Any issuance of purchase order prior to consigning back the Approval page of "Specification Sheets" from customers will be regarded as the agreement on the contents of these specifications.

**MSL:Level 1
RoHS Compliant**

PRODUCT SPECIFICATION SHEET

PRODUCT TYPE : SMD SEAM SEALING X'TAL 3.2x2.5

NOMINAL FREQ. : 20.736000MHz

TXC P/N : 7M20700003

REVISION : A1

| PE/RD | QA | MFG |
|---------------------------------------|-------------------------------------|---|
| <i>Shih-Yung Pao</i> Shih-Yung Pao | <i>Samson Xiong</i> Samson Xiong | <i>Min-Chiang Chao</i> Min-Chiang Chao |
| <i>19-Dec-12</i> | <i>19-Dec-12</i> | <i>19-Dec-12</i> |

NOTE:

- (1)Lead Free Products are "Directive 2002/95/EC of The European Parliament of 27 January 2003 on the restriction of the use of certain hazardous substances (RoHS) in electrical and electronic equipment" Compliant (Attachment: SGS Test Report).
- (2)Revision "Sx" is for engineering samples only. PE/RD's approval required.
- (3)Revision "Ax" is production ready. PE, QA and MFG's approval required

MSL:Level 1
RoHS Compliant

| <u>Rev</u> | <u>Revise page</u> | <u>Revise contents</u> | <u>Date</u> | <u>Ref.No.</u> | <u>Reviser</u> |
|------------|--------------------|---------------------------------|-------------|----------------|----------------|
| S1 | N/A | Initial released | 25-Jun-12 | N/A | Xiaoyan Jiang |
| S2 | N/A | Equivalent Resistance Rr Change | 10-Sep-12 | ECR-12N0910005 | Xiaoyan Jiang |
| A1 | N/A | S Turn A | 19-Dec-12 | N/A | Xiaoyan Jiang |
| | | | | | |
| | | | | | |
| | | | | | |
| | | | | | |
| | | | | | |
| | | | | | |
| | | | | | |
| | | | | | |
| | | | | | |
| | | | | | |
| | | | | | |
| | | | | | |
| | | | | | |
| | | | | | |
| | | | | | |
| | | | | | |
| | | | | | |
| | | | | | |
| | | | | | |
| | | | | | |
| | | | | | |

Spec Sheet Contents

| No. | Content | Page |
|-----|--|-------|
| 1 | ELECTRICAL SPECIFICATIONS | P.3 |
| 2 | FACTORY LOCATION | P.3 |
| 3 | DIMENSIONS | P.4 |
| 4 | MARKING | P.4 |
| 5 | SUGGESTED REFLOW PROFILE & MANUAL SOLDER CONDITION | P.4 |
| 6 | STRUCTURE ILLUSTRATION | P.5 |
| 7 | EMBOSS CARRIER TAPE & REEL | P.6 |
| 8 | PACKING | P.7 |
| 9 | RELIABILITY SPECIFICATIONS | P.8~9 |

■ ELECTRICAL SPECIFICATIONS

Standard atmospheric conditions

Unless otherwise specified, the standard range of atmospheric conditions for making measurement and tests are as follow:

- Ambient temperature : 25±5°C
- Relative humidity : 40%~70%

If there is any doubt about the results, measurement shall be made within the following limits:

- Ambient temperature : 25±3°C
- Relative humidity : 40%~70%

Measure equipment

Electrical characteristics measured by S&A250B or equivalent.

Crystal cutting type

The crystal is using AT CUT (thickness shear mode).

Unit Weight:

0.018±0.001 g/pcs

| | Parameters | SYM. | Electrical Spec. | | | | Notes |
|----|---------------------------|------|------------------|------|-----|-------|---|
| | | | MIN | TYPE | MAX | UNITS | |
| 1 | Nominal Frequency | FL | 20.736000 | | | MHz | - |
| 2 | Oscillation Mode | - | Fundamental | | | - | - |
| 3 | Load Capacitance | CL | 10 | | | pF | - |
| 4 | Frequency Tolerance | - | ±10 | | | ppm | at 25 °C ± 3 °C |
| 5 | Frequency Stability | - | ±15 | | | ppm | Over Operating Temp. Range (Reference 25°C) |
| 6 | Operating Temperature | - | -30 | ~ | 90 | °C | - |
| 7 | Aging | - | ±3 | | | ppm | 1st Year |
| 8 | Drive Level | DL | - | 100 | - | uW | - |
| 9 | Equivalent Resistance Rr | Rr | - | - | 30 | Ω | - |
| 10 | Shunt Capacitance C0 | C0 | - | - | 3 | pF | - |
| 11 | Insulation Resistance | - | 500 | - | - | MΩ | at DC 100V |
| 12 | Storage Temperature Range | - | -40 | ~ | 95 | °C | - |

■ FACTORY LOCATION

TXC (NINGBO) CORPORATION
 NO.189 Huang Shan West Road, Beilun District,
 Ningbo Zhejiang China

■ DIMENSIONS

(Unit:mm)

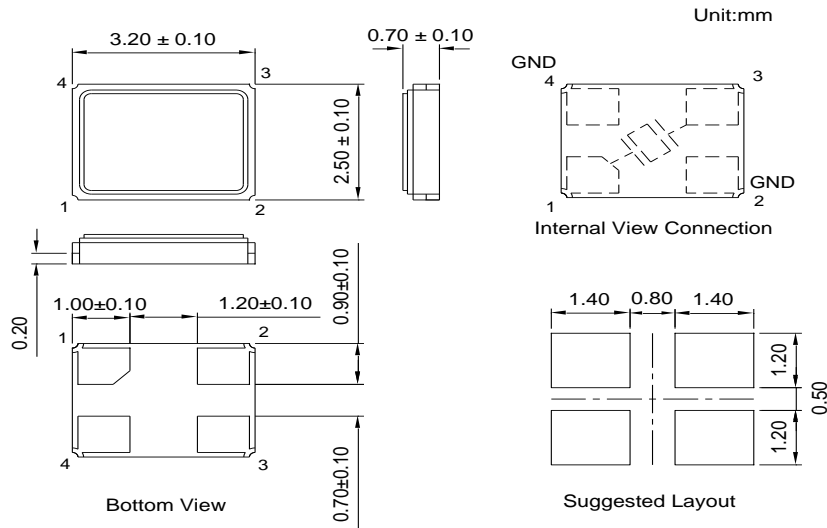

*Coplanarity of solderable areas Camber 0.10 mm Max

■ MARKING

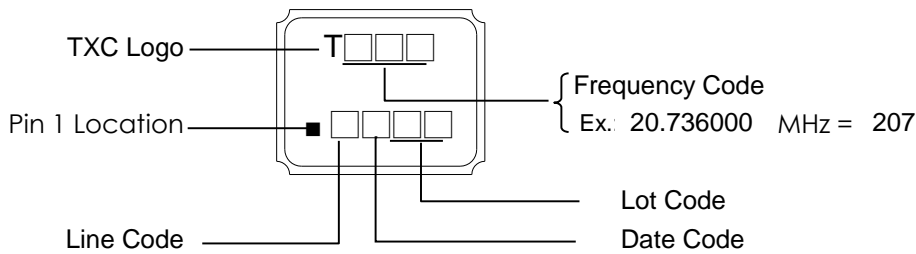

Date Code:

| YEAR | | MONTH | | | | | | | | | | | | | |
|------|------|-------|------|-----|-----|-----|-----|-----|-----|-----|-----|-----|-----|---|---|
| | | JAN | FEB | MAR | APR | MAY | JUN | JUL | AUG | SEP | OCT | NOV | DEC | | |
| 2005 | 2009 | 2013 | 2017 | A | B | C | D | E | F | G | H | J | K | L | M |
| 2006 | 2010 | 2014 | 2018 | N | P | Q | R | S | T | U | V | W | X | Y | Z |
| 2007 | 2011 | 2015 | 2019 | a | b | c | d | e | f | g | h | j | k | l | m |
| 2008 | 2012 | 2016 | 2020 | n | p | q | r | s | t | u | v | w | x | y | z |

*This date code will be cycled every four years

■ SUGGESTED REFLOW PROFILE

Solder melting point :220±10 °C, 60 sec. Min.
Peak Temperature: 260 ± 5 °C, 10 sec. Max.

■ SUGGESTED MANUAL SOLDER CONDITION

Temperature: 350 ± 10 °C
Time: 3 sec.
Re-solder times: twice

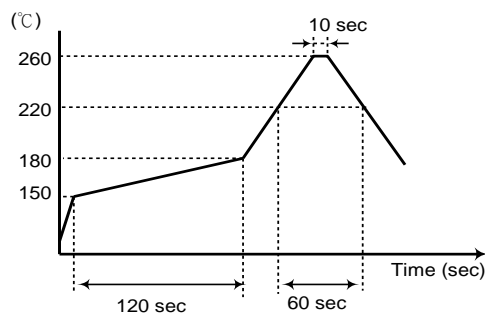

■ **STRUCTURE ILLUSTRATION**

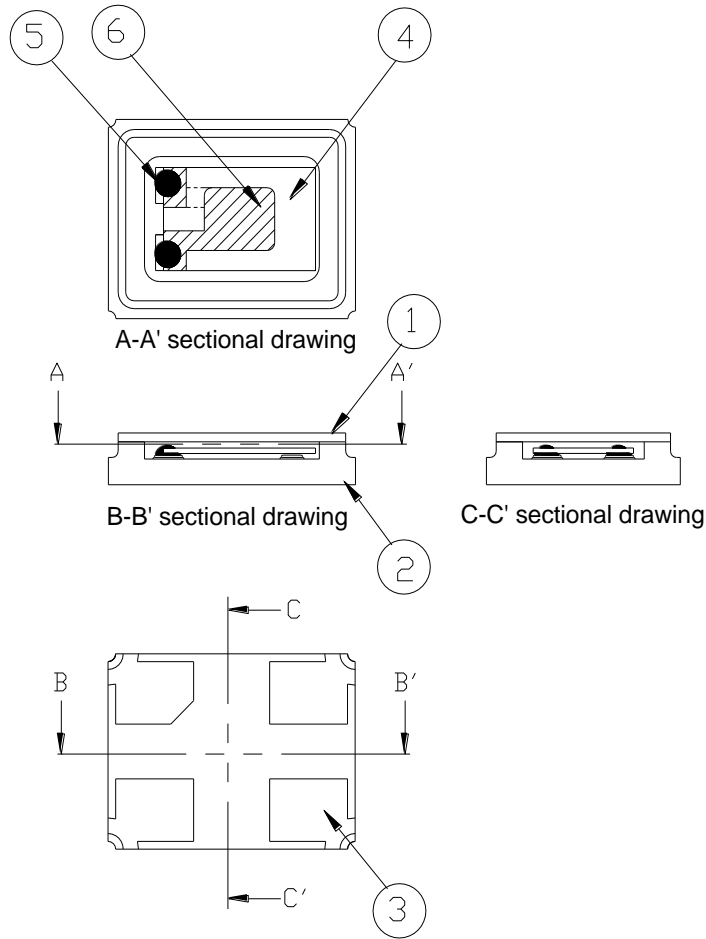

| NO | COMPONENTS | MATERIALS | FINISH/SPECIFICATIONS |
|----|---------------------|---|---|
| 1 | Lid | Kovar (Fe/Co/Ni) | - |
| 2 | Package | Ceramic (Al ₂ O ₃) + Kovar (Fe/Co/Ni)+ Ag/Cu | - |
| 3 | PAD | Au | Tungsten metalize + Ni plating + Au plating |
| 4 | Crystal blank | SiO ₂ | - |
| 5 | Conductive adhesive | Resin+Ag | - |
| 6 | Electrode | Noble Metal | - |

EMBOSS CARRIER TAPE & REEL

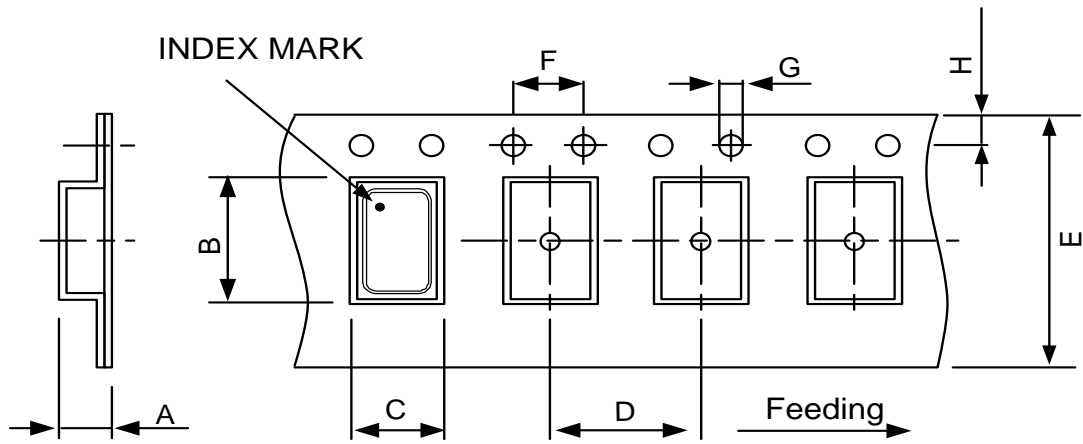

| | | | | | | | | | |
|------------|-----------|-----------|-----------|-----------|-----------|-----------|-----------|-----------|-------------|
| DIMENSIONS | A | B | C | D | E | F | G | H | |
| | 1.65±0.10 | 3.40±0.10 | 2.70±0.10 | 4.00±0.10 | 8.00±0.20 | 4.00±0.10 | 1.55±0.10 | 1.75±0.10 | (UNIT : mm) |

REMARK :

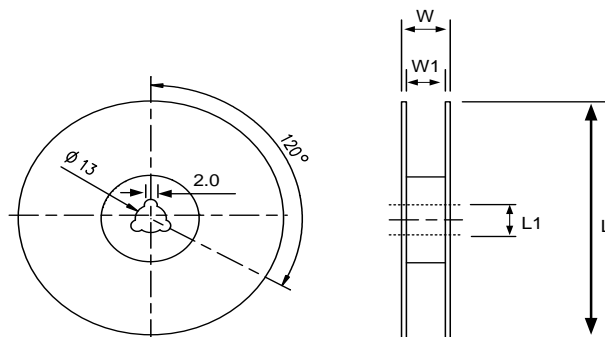
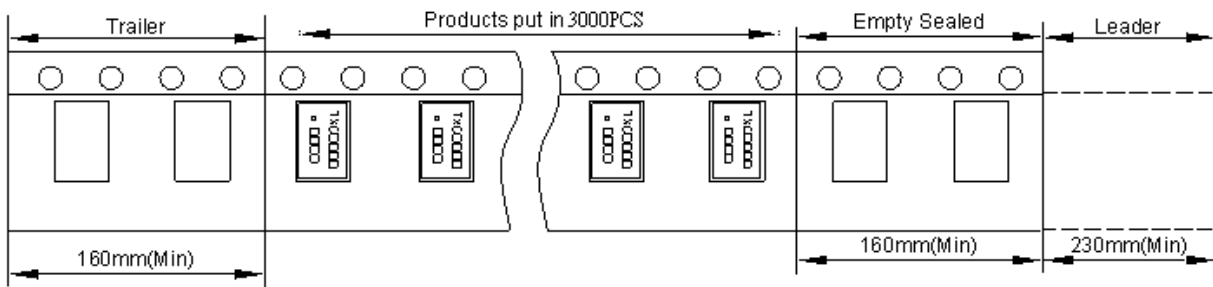

| | | | | | |
|------------|----------|---------|-----------|--------|-------------|
| DIMENSIONS | L | L1 | W | W1 | |
| | 178±1.00 | 13±0.50 | 11.5±0.20 | 8±0.10 | (UNIT : mm) |

PACKING

Reel Quantity :

- 1. Reel X 6 (6 Reels)
- 2. Reel X 12 (12 Reels)
- 3. Reel X 25 (12 Reels + 13 Reels)
- 4. Reel X 50 (12 Reelsx2 + 13 Reelsx2)

Box Size:

- 1. L200 X W200 X H140mm
- 2. L200 X W200 X H250mm
- 3. L400 X W200 X H250mm
- 4. L400 X W400 X H280mm

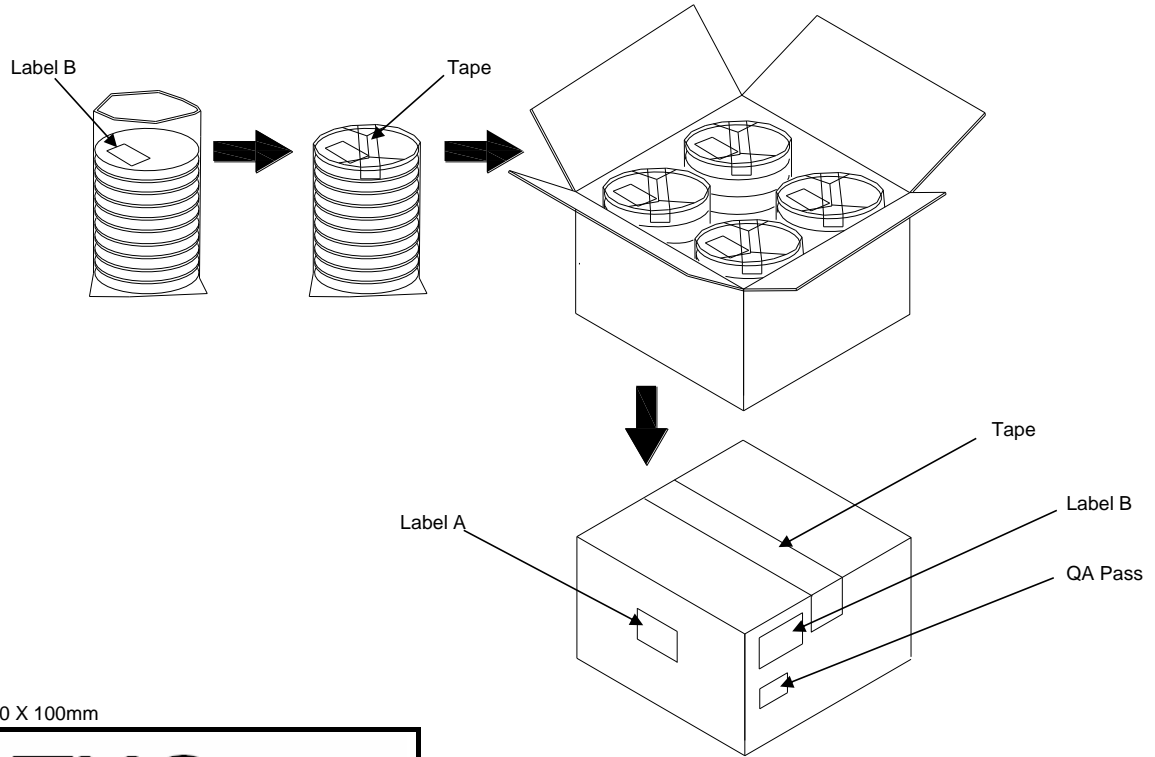

(Label A) Size:100 X 100mm

| |
|--|
| TXC |
| Inv No: 00096815 |
| Po No: 21106326- 24- 1 |
| Part No: |
| Q'ty: 40000 PCS |
| C/No: 157- 44 |

(Label B) Size:80 X 40mm

| | | |
|-----------------|-------------|------------|
| TXC CORPORATION | | QA PASS |
| DATE CODE: | QTY: | 2011/09/02 |
| LOT NO: | RoHS | |
| PART NO: | HF | |
| FREQ: | | |

[STORAGE]

- 1.The storage time to be 1 year maximum.
- 2.Don't be caught in the rain.
- 3.The storage environment shall be 5°C ~40°C temperature and 30% ~ 75%RH humidity and free from the sun shine.
- 4.If customers have special requirements, we can paste labels according to it.

RELIABILITY SPECIFICATIONS

1.Mechanical Endurance

| No. | Test Item | Test Methods | Test Criteria |
|-----|------------------|---|---------------|
| 1.1 | Drop Test | 150 cm height,3 times on concrete floor . | A . C |
| 1.2 | Mechanical Shock | Device are shocked to half sine wave (1000 G) three mutually perpendicular axes each 3 times. 0.5 ms duration time | A . C |
| 1.3 | Vibration | Frequency range 10 ~ 2000 Hz Amplitude 1.52 mm/20G Sweep time 20 minutes Perpendicular axes each test time 4 Hrs (Total test time 12 Hrs) | A . C |
| 1.4 | Solderability | Temperature 245 °C ± 5°C Immersing depth 0.5 mm minimum Immersion time 5 ± 1 seconds Flux Rosin resin methyl alcohol solvent (1 : 4) | E |

2.Environmental Endurance

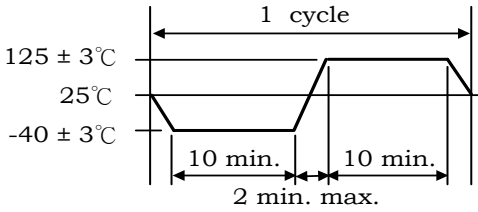
| No. | Test Item | Test Methods | Test Criteria |
|-----|------------------------------|--|---------------|
| 2.1 | Resistance To Soldering Heat | Pre-heat temperature 125 °C Pre-heat time 60 ~ 120 sec. Test temperature 260 ± 5 °C Test time 10 ± 1 sec. | B . C . D |
| 2.2 | High Temp. Storage | + 125 °C ± 3 °C for 500 ± 12 Hrs | B . C . D |
| 2.3 | Low Temp. Storage | - 40 °C ± 3 °C for 500 ± 12 Hrs | B . C . D |
| 2.4 | Temperature cycle | Total 100 cycles of the following temperature cycle  | B . C . D |
| 2.5 | High Temp & Humidity | 85°C ± 3°C , RH 85% , 500 Hrs | B . C . D |

RELIABILITY SPECIFICATIONS

| Specifications | |
|----------------|---|
| A | Frequency change: Within ± 5 ppm or in customer's specification. |
| B | Frequency change: Within ± 10 ppm or in customer's specification. |
| C | Equivalent series resistance(E.S.R) change: Within $\pm 15\%$ or 10Ω (larger value). |
| D | After conditioning , quartz crystal units shall be subjected to standard atmospheric conditions for 2 hour, and measured. |
| E | Minimum 95% of immersed terminal shall be covered with new uniform solder. |

Measurement condition

Electrical characteristics measured by S&A250B or equivalent.

X-ON Electronics

Largest Supplier of Electrical and Electronic Components

Click to view similar products for [Crystals](#) category:

Click to view products by [TXC Corporation](#) manufacturer:

Other Similar products are found below :

[CX3225GB25000M0PPSZ1](#) [718-13.2-1](#) [MC405 32.0000K-R3:PURE SN](#) [7A-40.000MAAE-T](#) [FL2000085](#) [99-BU](#) [9B-15.360MBBK-B](#) [9C-7.680MBBK-T](#) [H10S-12.000-18-EXT-TR](#) [ABC2-6.000MHZ-D4Z-T](#) [ABLS-20.000MHZ-D2-T](#) [ABS071-32.768KHZ-6-T](#) [R38-32.768-12.5-5PPM-NPB](#) [BTD1062E05A-513](#) [21U15A-21.4MHZ](#) [RTX-781DF1-S-20.950](#) [LFXTAL066198Cutt](#) [9C-14.31818MBBK-T](#) [A-11.000MHZ-27](#) [ABL-27.000MHZ-B4Y-T](#) [ABM11-132-24.000MHZ-T3](#) [ABM3B1-25.000MHZ-D2Y-T](#) [SPT2A-.032768B](#) [SPT2A.032768G](#) [SSPT7F-9PF20-R](#) [FX325BS-38.88EEM1201](#) [LFXTAL065253Cutt](#) [LFXTAL066431Cutt](#) [XT9S20ANA14M7456](#) [XT9SNLANA16M](#) [7A-24.576MBBK-T](#) [7B-30.000MBBK-T](#) [MMCC2R32.7680KHZ](#) [7A-14.31818MBBK-T](#) [6504-202-1501](#) [6526-202-1501](#) [ABLS-12.000MHZ-B2Y-T](#) [7A-10.000MBBK-T](#) [SG636PCE-20.000MC](#) [3404](#) [E1SAA18-25.000M TR](#) [CM315D32768EZFT](#) [C1E-24.000-7-2020-R](#) [C1E-19.200-12-1530-X-R](#) [C1E-16.000-12-1530-X-R](#) [ABM11-16.000MHZ-9-B1U-T](#) [FL5000014](#) [EUCA18-3.1872M](#) [FX0800015](#) [425F35E027M0000](#)