



TXC CORPORATION

4F, NO. 16, Sec. 2 Chung Yang S Rd., Peitou, Taipei, Taiwan.

TEL : 886-2-2894-1202 , 886-2-2895-2201 FAX : 886-2-2894-1206 , 886-2-2895-6207

www.txccorp.com

SPECIFICATION FOR APPROVAL

CN: 1508013446

CUSTOMER : _____

PRODUCT TYPE : HC-49/S SMD

NOMINAL FREQ. : 4.000000MHz

TXC P/N : AT04000019

REVISION : A1

CUSTOMER P/N : _____

PM / SALES : _____

DATE : _____

CUSTOMER SIGNATURE & Date

- (1) TXC requires one copy returned with signature and title of authorized individual that signifies acceptance of the attached specifications.
- (2) Orders received and accepted by TXC after return of signed copy of specification will be produced per these specifications.
- (3) Any changes to these specifications must be agreed upon by both parties and new revision of the Product Specification Sheet will be issued.
- (4) Any issuance of purchase order prior to consigning back the Approval page of "Specification Sheets" from customers will be regarded as the agreement on the contents of these specifications.

Attachment: Product Specification Sheet

- 1
- 2
- 3
- 4
- 5

RoHS Compliant



TXC CORPORATION

4F, NO. 16, Sec. 2 Chung Yang S Rd., Peitou, Taipei, Taiwan.

TEL : 886-2-2894-1202 , 886-2-2895-2201 FAX : 886-2-2894-1206 , 886-2-2895-6207

www.txccorp.com

PRODUCT SPECIFICATION SHEET

CN: 1508013446

PRODUCT TYPE : HC-49/S SMD

NOMINAL FREQ. : 4.000000MHz

TXC P/N : AT04000019

REVISION : A1

PE/RD	QA	MFG
<i>Wen yuan Chang</i>	<i>ZhongLin Wu</i>	<i>Zhi Jun Wu</i>
Wen yuan Chang	ZhongLin Wu	Zhi jun Wu
27-Aug-14	27-Aug-14	27-Aug-14

NOTE:

(1)The green product standard set by TXC is based upon the international standards. Related information is publicly described on the TXC's Website, and updated regularly. The document is compliant with the latest green product quality system directives at the time.

(2)Revision "Sx" is for engineering samples only. PE/RD's approval required.

(3)Revision "Ax" is production ready. PE, QA and MFG's approval required

RoHS Compliant



Spec Sheet Contents

No.	Content	Page
1	ELECTRICAL SPECIFICATIONS	P.3
2	FACTORY LOCATION	P.3
3	DIMENSIONS	P.4
4	SUGGESTED REFLOW PROFILE& MANUAL SOLDER CONDITION	P.4
5	MARKING	P.5
6	STRUCTURE ILLUSTRATION	P.6
7	EMBOSS CARRIER TAPE & REEL	P.7
8	PACKING	P.7
9	RELIABILITY SPECIFICATIONS	P.8~9

ELECTRICAL SPECIFICATIONS

Standard atmospheric conditions

Unless otherwise specified, the standard range of atmospheric conditions for making measurement and tests are as follow:

- Ambient temperature : 25+/-5°C
- Relative humidity : 40%~70%

If there is any doubt about the results, measurement shall be made within the following limits:

- Ambient temperature : 25+/-1°C
- Relative humidity : 40%~70%

Measure equipment

SAUNDERS 250A/250B CRYSTAL IMPEDANCE METER.

Crystal cutting type

The crystal is using AT CUT (thickness shear mode).

Unit Weight:

0.58±0.050 g/pcs

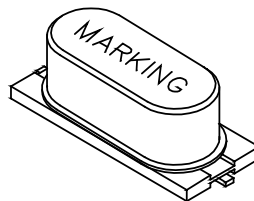

please refer to marking code page

	Parameters	SYM.	Electrical Spec.				Notes
			MIN	TYPE	MAX	UNITS	
1	Nominal Frequency	FL	4.000000			MHz	-
2	Oscillation Mode	-	Fundamental			-	-
3	Load Capacitance	CL	17			pF	-
4	Frequency Tolerance	-	±25			ppm	at 25 °C ± 3 °C
5	Frequency Stability	-	±30			ppm	Over Operating Temp. Range (Reference 25°C)
6	Operating Temperature	-	-40	~	85	°C	-
7	Aging	-	±3			ppm	1st Year
8	Drive Level	DL	-	100	-	uW	-
9	Effective Resistance Rr	Rr	-	-	120	Ω	-
10	Shunt Capacitance C0	C0	-	-	7	pF	-
11	Insulation Resistance	-	500	-	-	MΩ	at DC 100V
12	Storage Temperature Range	-	-40	~	85	°C	-

FACTORY LOCATION

TXC (NINGBO) CORPORATION
 NO.189 Huang Shan West Road, Beilun District,
 Ningbo Zhejiang China

DIMENSIONS

UNIT:mm

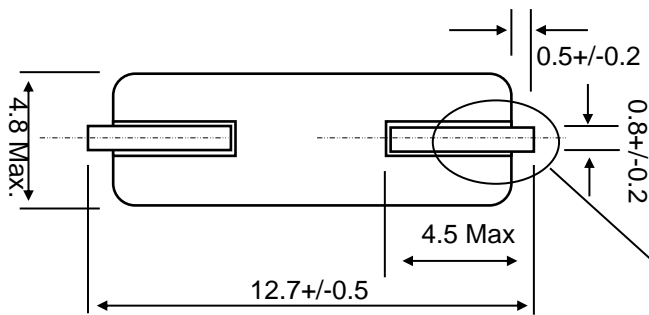
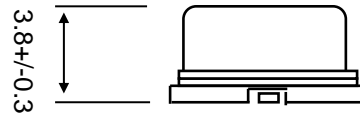
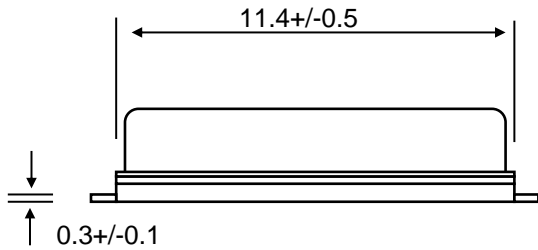

Solder Coating
(Sn-Ag-Cu Pb Free Coating)

Suggested Layout

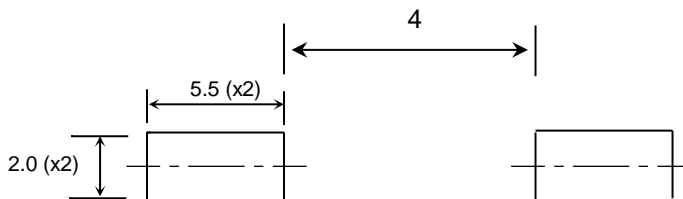

■ SUGGESTED REFLOW PROFILE

Solder melting point : 220 ± 10 °C, 60 sec. Min.
Peak Temperature: 260 ± 5 °C, 10 sec. Max.

■ SUGGESTED MANUAL SOLDER CONDITION

Temperature: 350 ± 10 °C
Time: 3 sec.
Re-solder times: twice

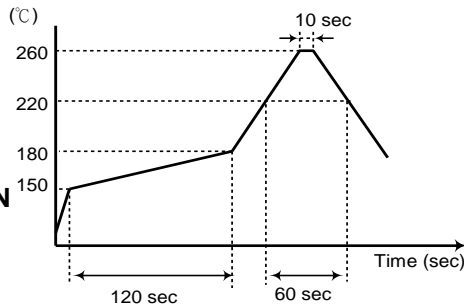

MARKING

Marking For Pb Free Parts :

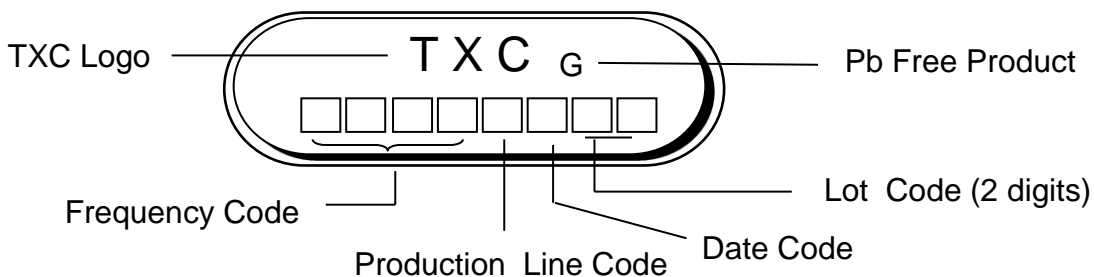

Date Code:

YEAR \ MONTH					JAN	FEB	MAR	APR	MAY	JUN	JUL	AUG	SEP	OCT	NOV	DEC
					A	B	C	D	E	F	G	H	J	K	L	M
2001	2005	2009	2013	2017	N	P	Q	R	S	T	U	V	W	X	Y	Z
2002	2006	2010	2014	2018	a	b	c	d	e	f	g	h	j	k	l	m
2003	2007	2011	2015	2019	n	p	q	r	s	t	u	v	w	x	y	z
2004	2008	2012	2016	2020												

*This date code will be cycled every four years.

For example : Marking

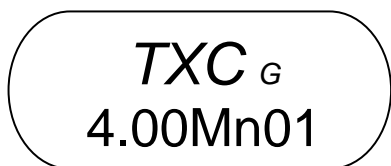

→
Introduction : Pb Free Product
49S/SMD 4.000000 MHz
Made in NGB 2008/JAN 01Lot

■ **STRUCTURE ILLUSTRATION**

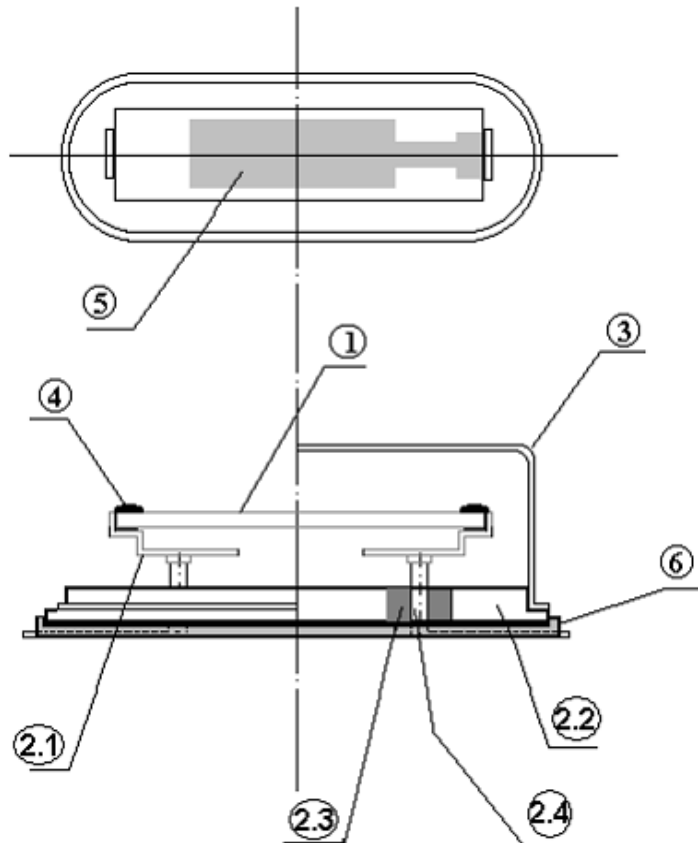

NO	COMPONENTS	MATERIALS	FINISH/SPECIFICATIONS
1	CRYSTAL BLANK	QUARTZ(SiO ₂)	-
2	CRYSTAL BASE	SUPPORTER	Nickel Silver(Cu/Zn/Ni)
		HOLDER	SPCC(Fe)
		GLASS	GLASS
		LEAD	Kovar (Fe/Co/Ni)
3	CRYSTAL COVER	Nickel Silver(Cu/Zn/Ni)	Ni Plated
4	CONDUCTIVE ADHESIVE	Resin + Ag	-
5	ELECTRODE	Noble Metal	-
6	INSULATION PAD	PPS	-

(A) Tape and reel configuration:(Unit : mm)

(a) Emboss tapping configuration. (per EIA-481-2)

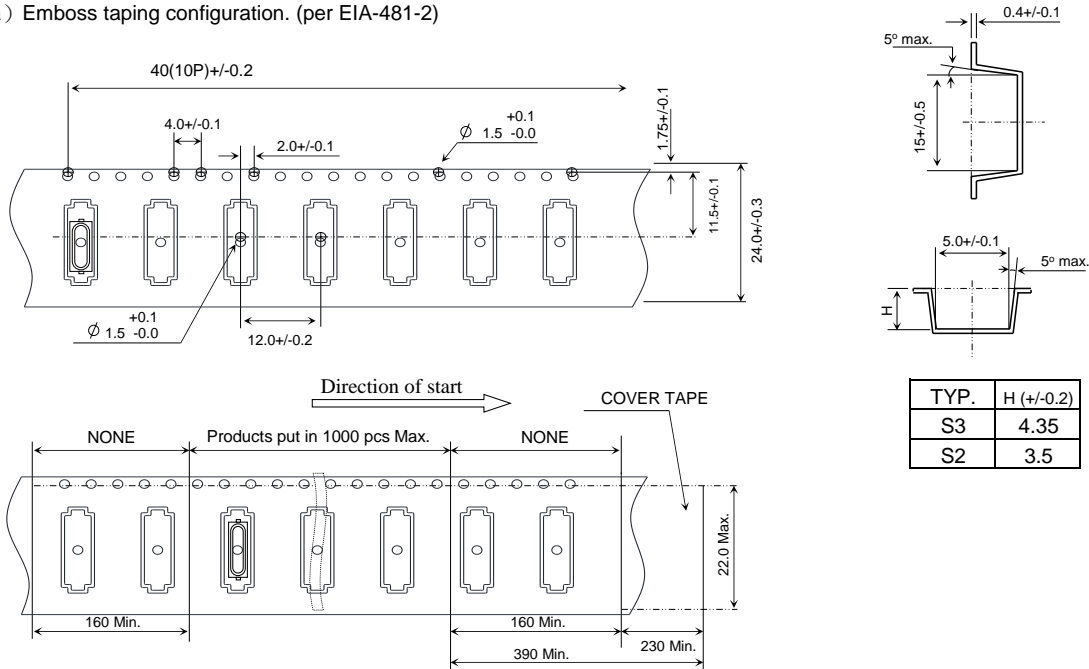

(b) Reel configuration.

(B) Packing & Label :(Unit : mm)

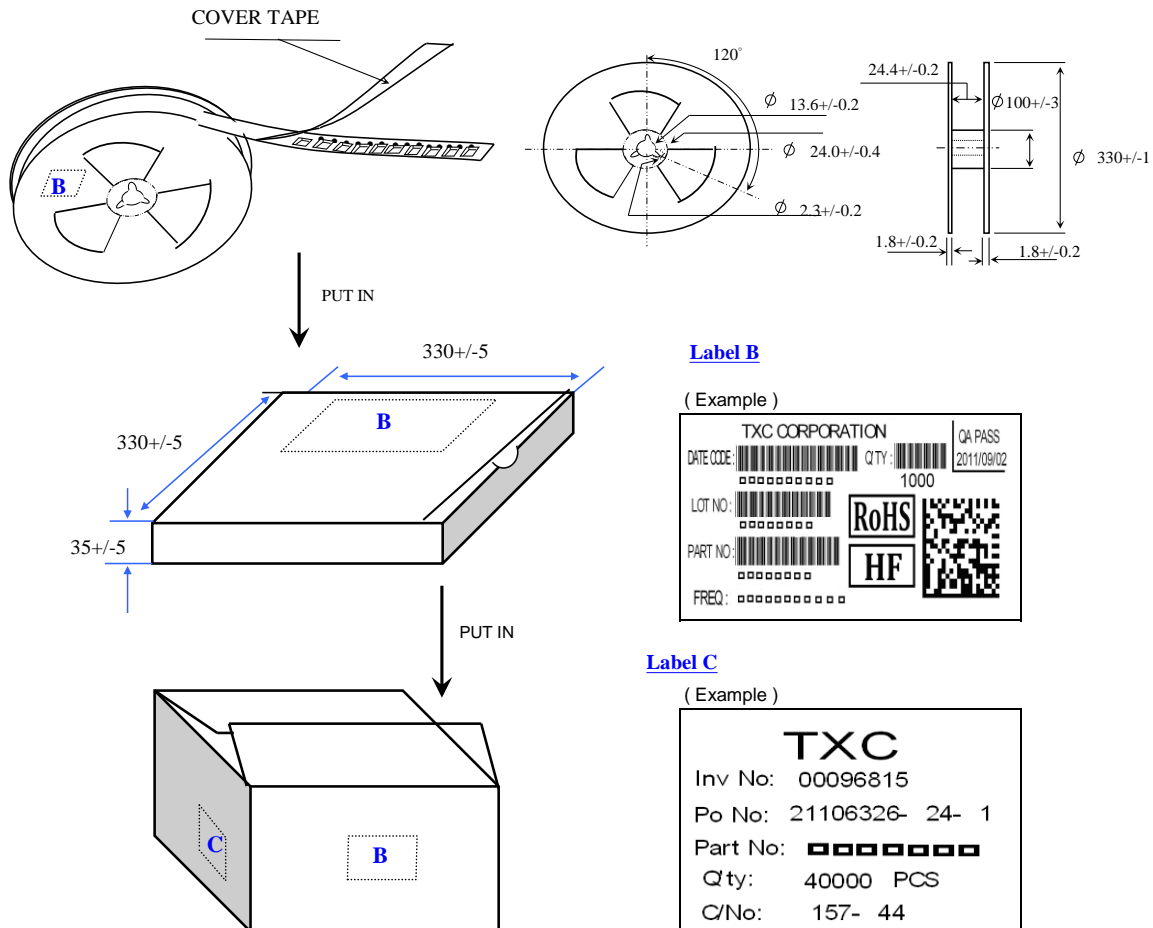

Put in stuff between space.

[STORAGE]

- 1.The storage time to be 1 year maximum.
- 2.Don't be caught in the rain.
- 3.The storage environment shall be 5°C ~40°C temperature and 30% ~ 75%RH humidity and free from the sun shine.
- 4.If customers have special requirements, we can paste labels according to it.

■ RELIABILITY SPECIFICATIONS (AEC-Q200 Compliant)
1.Mechanical Endurance

No.	Test Item	Test Methods	Test Criteria
1.1	Mechanical Shock	1000 G , 0.5 m Sec. , 3 times for all 3 directions.	B C
1.2	Vibration	Frequency range 10 ~ 2000 Hz Acceleration 20 G Sweep time 20 minute Pencil axes each test time 4 hours (Total test time 12 hours)	B C
1.3	Terminal Strength	17.7N force for 60sec +/-1sec.	F
1.4	Board Flex	Duration time:60 Sec Minimum,Deviation:3mm	B C
1.5	Solderability	Temperature 245 °C +/- 5°C Immersing depth 0.5 mm minimum Immersion time 5 +/- 0.5 seconds Flux Rosin resin methyl alcohol solvent (1 : 4)	E

2.Environmental Endurance

No.	Test Item	Test Methods	SPEC
2.1	Resistance To Soldering Heat	Test temperature 260 +/- 5 °C Test time 10 +/- 1 sec.	ACD
2.2	High Temp. Storage	+ 85°C ± 3 °C for 1000 ± 12 Hrs	ACD
2.3	Low Temp. Storage	- 40 °C ± 3 °C for 1000 ± 12 Hrs	ACD
2.4	Temperature cycle	-40°C ~85°C ,for 1000 cycles. 	ACD
2.5	Operational Life	1000 hrs @ 85± 3°C. Rated VDD applied with 1 MΩ.	ACD
2.6	High Temp & Humidity	85°C ± 3°C , RH 85% , 1000 Hrs	ACD

RELIABILITY SPECIFICATIONS

Specifications	
A	Frequency change: Within ± 20 ppm or in customer's specification.
B	Frequency change: Within ± 10 ppm or in customer's specification.
C	Equivalent series resistance(E.S.R) change: Within $\pm 15\%$ or 10Ω (larger value).
D	After conditioning , quartz crystal units shall be subjected to standard atmospheric conditions for 24 hour, and measured.
E	Minimum 95% of immersed terminal shall be covered with new uniform solder.
F	No damage on specimen

Measurement condition

Measurements are carried out with Network-analyzer(S&A 250B or equivalent).

X-ON Electronics

Largest Supplier of Electrical and Electronic Components

Click to view similar products for [Crystals category](#):

Click to view products by [TXC Corporation manufacturer](#):

Other Similar products are found below :

[CS325S24000000ABJT](#) [718-13.2-1](#) [MC405 32.0000K-R3:PURE SN](#) [FC-135R 32.7680KF-A3](#) [7A-40.000MAAE-T](#) [7B-27.000MBBK-T](#)
[FL2000085](#) [9B-15.360MBBK-B](#) [9C-7.680MBBK-T](#) [ASH7K-32.768KHZ](#) [AT-41.600MAGQ-T](#) [BTD1062E05A-513](#) [LFX TAL066198Cutt](#)
[9C-14.31818MBBK-T](#) [FA-238 50.0000MB30X-K3](#) [FC-12M 32.7680KA-AC3](#) [SSPT7F-9PF20-R](#) [FX325BS-38.88EEM1201](#)
[LFX TAL065253Cutt](#) [LFX TAL066431Cutt](#) [XT9S20ANA14M7456](#) [XT9SNLANA16M](#) [646G-24-2](#) [7A-24.576MBBK-T](#) [7B-30.000MBBK-T](#)
[WX26-32.768K-6PF](#) [9B-14.31818MBBK-B](#) [CD1AM](#) [7B-25.000MAAE-T](#) [7A-14.31818MBBK-T](#) [6504-202-1501](#) [6526-202-1501](#) [FA-118T](#)
[27.1200MB50P-K0](#) [FC-135R 32.7680KA-A3](#) [ABM12-104-37.400MHZT](#) [ABLS-10.000MHZ-D3W-T](#) [BTJ112E01E-513](#) [BTJ722K01C-7067](#)
[BTL-20-513](#) [TSX-3225 24.0000MF15X-AC](#) [TSX-3225 16.0000MF18X-AC](#) [BTJ120E02C](#) [BTL-12-513](#) [7A-10.000MBBK-T](#) [7A-](#)
[11.0592MBBK-T](#) [ABM12-103-24.000MHZT](#) [CS325S25000000ABJT](#) [ABM3B-25.000MHZ-B2-X-T](#) [FC-135 32.7680KA-A5](#) [FX0800015](#)