

| REV | LOCATIONS | DESCRIPTION | DATE | REVISER | APPD |
|-----|-----------|------------------------|-----------|---------|------|
| 1 | △ | Structure optimization | 17/AUG/18 | KATE | ANDY |

SPECIFICATIONS

Electrical
 Current Rating: 0.5A AC(rms)/DC
 Voltage Rating: 50V AC(rms)/DC
 Contact Resistance: 30 mΩ Max
 Insulation Resistance: 500 MΩ MIN
 Withstanding Voltage: 200V AC r.m.s
 Temperature Range-Operating: -25°C~+85°C
 Material And Plating
 Housing: Thermoplastic UL94V-0/ Natural
 Actuator: Thermoplastic UL94V-0/ Black
 Terminal: Copper Alloy /Gold plated
 LEG: Copper Alloy /Tin plated

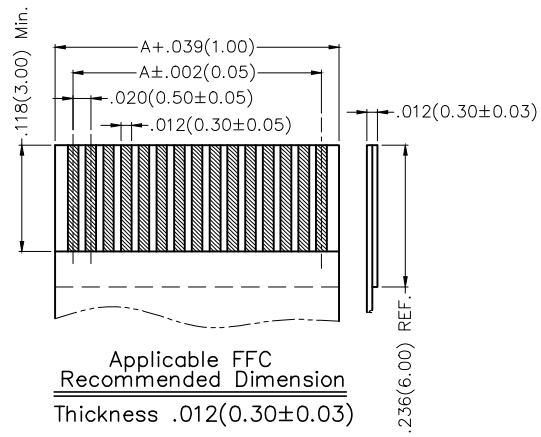
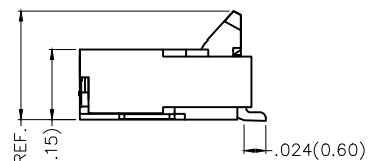
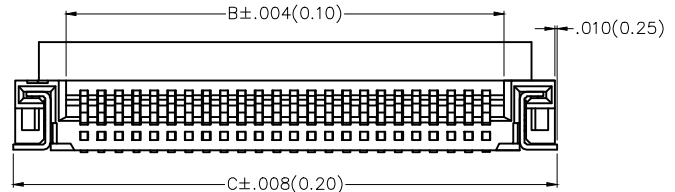
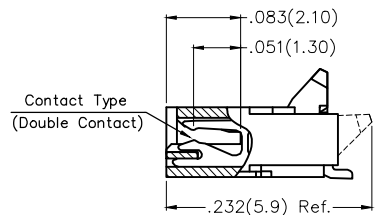
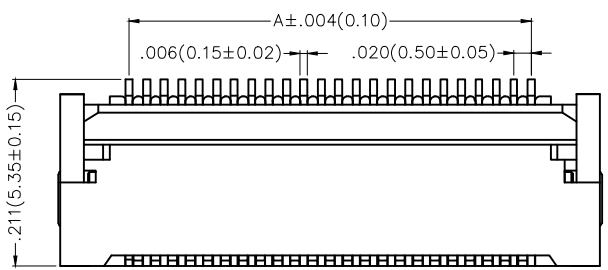

Applicable FFC
 Recommended Dimension
 Thickness .012(0.30±0.03)

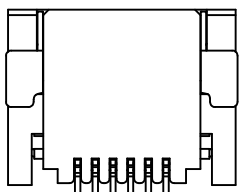
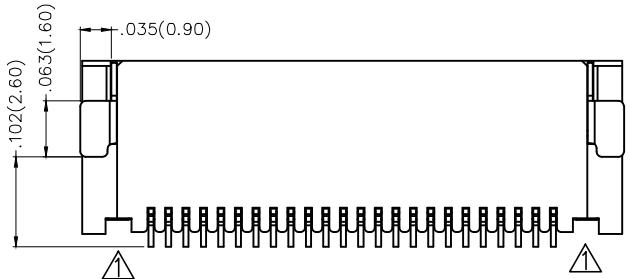

No.4~14 Circuits

Ordering Information

| | | | | | | | | | | | | |
|-----|-----|----|---|----|---|---|---|---|---|----|----|----|
| FFC | 050 | 36 | — | XX | S | B | D | 1 | 1 | 3 | W5 | M |
| 1 | 2 | 3 | | 4 | 5 | 6 | 7 | 8 | 9 | 10 | 11 | 12 |

| | | | | | |
|------------------------------------|------------------------------------|----------------------------|----------------------------|---|-------------------------------|
| 1 Category FFC-FPC | 2 Series Number 050-Pitch0.50mm | 3 Distinction No. 36 | 4 Circuits XX | 5 Assemble Layout S-SMT | 6 Entry Angle B- 90° Angle |
| 7 Contact Type D-Double Contact | 8 ZIF 1-ZIF | 9 Plating 1-Gold plated | 10 Material-Resin 3-LCP | 11 Color-Resin W5-Housing: Natural, Actuator: Black | 12 Packaging M-Reel |

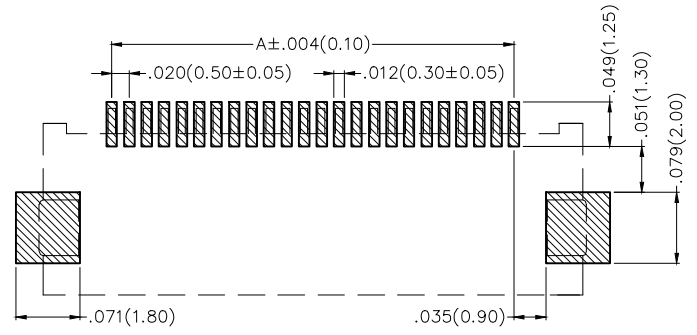

Recommended P.C.Board Layout
 General tolerances: ±.020(0.05)

| | | | | | | | |
|------------------------|---------------------------------------|----------------------------|----------------------|-------------------|--|----------------------|---|
| THIRD ANGLE PROJECTION | GENERAL TOLERANCES (UNLESS SPECIFIED) | | APPROVE BY FRANK | DATE 18/JUN/13 | PART NO. FFC05036-XXSBD113W5M | ITEM NO. FFC05036 |  Leader Of Industry |
| | DESIGN UNITS Inch (metric) | X.±.012(0.30) X.±5° | CHECKED BY CHERRY | DATE 18/JUN/13 | TITLE FPC/FFC connector 0.5mm Double contact SMT | | |
| SCALE 5:1 | SIZE A4 | X.XX±.006(0.15) X.XX±1° | DRAWN BY KATE | DATE 18/JUN/13 | THIS DRAWING CONTAINS INFORMATION THAT IS PROPRIETARY TO TXGA INDUSTRIAL ELECTRONICS(S.Z)CO.,LTD AND SHOULD NOT BE USED WITHOUT WRITTEN PERMISSION | | |



1 2 3 4 5 6 7 8

| REV | LOCATIONS | DESCRIPTION | DATE | REVISER | APPD |
|-----|-----------|-------------|------|---------|------|
| | | | | | |

A
B
C
D
E
F

A
B
C
D
E
F

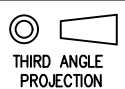
| Circuits (n) | Part No. | Dimensions(in/mm) | | |
|--------------|----------------------|-------------------|--------------|--------------|
| | | A | B | C |
| 4 | FFC05036-04SBD113W5M | .059(1.50) | .102(2.60) | .217(5.50) |
| 6 | FFC05036-06SBD113W5M | .098(2.50) | .142(3.60) | .256(6.50) |
| 8 | FFC05036-08SBD113W5M | .138(3.50) | .181(4.60) | .295(7.50) |
| 10 | FFC05036-10SBD113W5M | .177(4.50) | .220(5.60) | .335(8.50) |
| 12 | FFC05036-12SBD113W5M | .217(5.50) | .260(6.60) | .374(9.50) |
| 14 | FFC05036-14SBD113W5M | .256(6.50) | .299(7.60) | .413(10.50) |
| 16 | FFC05036-16SBD113W5M | .295(7.50) | .339(8.60) | .453(11.50) |
| 18 | FFC05036-18SBD113W5M | .335(8.50) | .378(9.60) | .492(12.50) |
| 20 | FFC05036-20SBD113W5M | .374(9.50) | .417(10.60) | .531(13.50) |
| 24 | FFC05036-24SBD113W5M | .453(11.50) | .496(12.60) | .610(15.50) |
| 26 | FFC05036-26SBD113W5M | .492(12.50) | .535(13.60) | .650(16.50) |
| 28 | FFC05036-28SBD113W5M | .531(13.50) | .575(14.60) | .689(17.50) |
| 30 | FFC05036-30SBD113W5M | .571(14.50) | .614(15.60) | .728(18.50) |
| 32 | FFC05036-32SBD113W5M | .610(15.50) | .654(16.60) | .768(19.50) |
| 36 | FFC05036-36SBD113W5M | .689(17.50) | .732(18.60) | .846(21.50) |
| 40 | FFC05036-40SBD113W5M | .768(19.50) | .811(20.60) | .925(23.50) |
| 45 | FFC05036-45SBD113W5M | .866(22.00) | .909(23.10) | 1.024(26.00) |
| 50 | FFC05036-50SBD113W5M | .965(24.50) | 1.008(25.60) | 1.122(28.50) |
| 54 | FFC05036-54SBD113W5M | 1.043(26.50) | 1.087(27.60) | 1.201(30.50) |
| 60 | FFC05036-60SBD113W5M | 1.161(29.50) | 1.205(30.60) | 1.319(33.50) |

| | | | | | | | | |
|--|---------------------------------------|--|--|----------------------|--|--|---|---------------|
|  THIRD ANGLE PROJECTION | GENERAL TOLERANCES (UNLESS SPECIFIED) | | APPROVE BY FRANK | DATE 18/JUN/13 | PART NO. FFC05036-XXSBD113W5M | ITEM NO. FFC05036 |  Leader Of Industry | |
| | DESIGN UNITS Inch (metric) | X.±.012(0.30) X.X±.008(0.20) X.XX±.006(0.15) X.XXX±.004(0.10) | X.±5° .X'±2° .XX'±1° .XXX'±0.5° | CHECKED BY CHERRY | DATE 18/JUN/13 | TITLE FPC/FFC connector 0.5mm Double contact SMT | | |
| SCALE 5:1 | SIZE A4 | DRAWN BY KATE | | DATE 18/JUN/13 | THIS DRAWING CONTAINS INFORMATION THAT IS PROPRIETARY TO TXGA INDUSTRIAL ELECTRONICS(S.Z)CO.,LTD AND SHOULD NOT BE USED WITHOUT WRITTEN PERMISSION | | REV 1 | SHEET NO. 2/3 |

1 2 3 4 5 6 7 8

| REV | LOCATIONS | DESCRIPTION | DATE | REVISER | APPD |
|-----|-----------|-------------|------|---------|------|
| | | | | | |

A
B
C
D
E
F

A
B
C
D
E
F

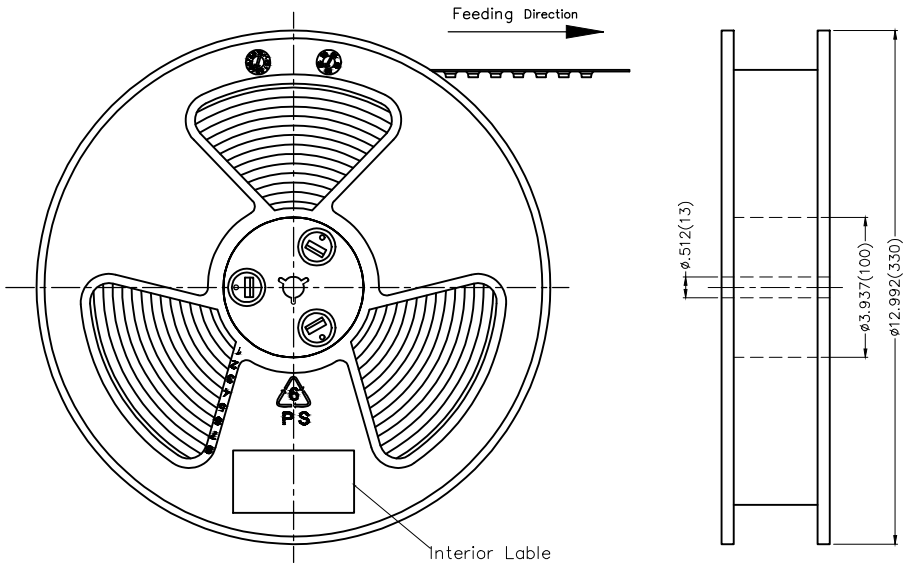

- Note:
1. 10 sprocket hole cumulative tolerance ± 0.2
 2. Carrier camber is within 1.0mm in 250mm
 3. Material: White Conductive polystyrene Alloy 100% recyclable
 4. All dimensions meet EIA-481-3 requirements
 5. Peel off force of cover tape & carrier tape: 20g~130g(0.2N~1.3N)
 6. Component load per 13" reel: 1,500 pcs

| Circuits (n) | Dimensions(in/mm) | | |
|--------------|-------------------|--------------|--------------|
| | A | B | C |
| 4~20 | .945(24.0) | .453(11.5) | — |
| 24~32 | 1.260(32.0) | .561(14.25) | 1.033(28.50) |
| 36~50 | 1.732(44.0) | .797(20.25) | 1.594(40.50) |
| 54~60 | 2.205(56.0) | 1.033(26.25) | 2.067(52.50) |

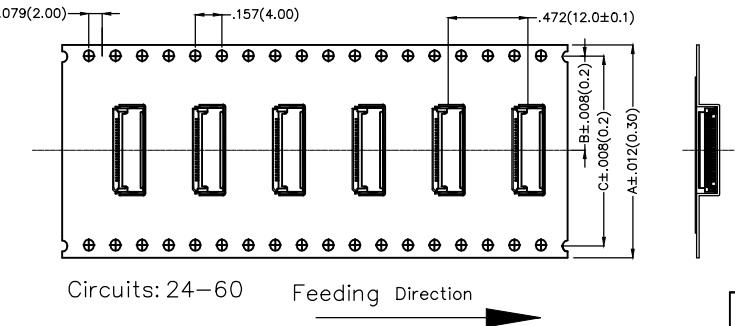
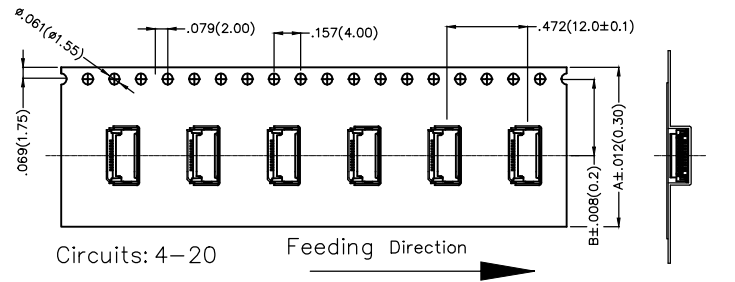
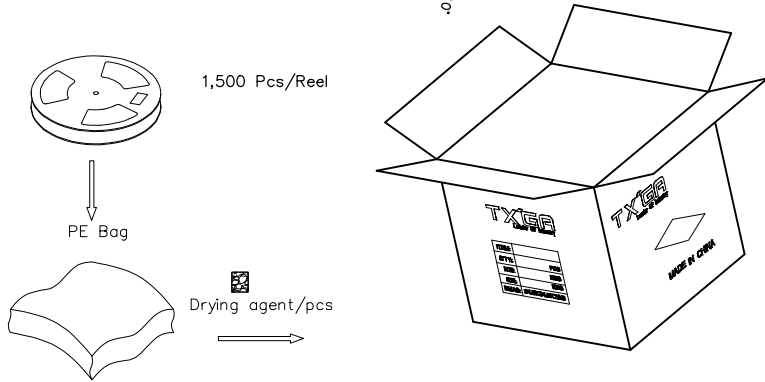
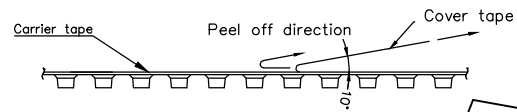
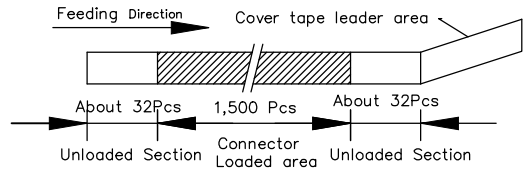

| | | | | | | | |
|-------------------------------|---------------------------------------|------------|------------|-----------|--|----------|------------------------|
| THIRD ANGLE PROJECTION | GENERAL TOLERANCES (UNLESS SPECIFIED) | | APPROVE BY | DATE | PART NO. | ITEM NO. | Leader Of Industry |
| | X.±.012(0.30) | X.±5' | FRANK | 18/JUN/13 | FFC05036-XXSBD113W5M | FFC05036 | |
| DESIGN UNITS Inch (metric) | X.X±.008(0.20) | .X'±2' | CHECKED BY | DATE | TITLE | | REV 1 SHEET NO. 3/3 |
| SCALE | X.XX±.006(0.15) | .XX'±1' | JACOB | 18/JUN/13 | FPC/FFC connector 0.5mm Double contact SMT | | |
| SIZE | X.XXX±.004(0.10) | .XXX'±0.5' | DRAWN BY | DATE | THIS DRAWING CONTAINS INFORMATION THAT IS PROPRIETARY TO TXGA INDUSTRIAL ELECTRONICS(S.Z)CO.,LTD AND SHOULD NOT BE USED WITHOUT WRITTEN PERMISSION | | APPD |
| 5:1 | A4 | | KATE | 18/JUN/13 | | | |

X-ON Electronics

Largest Supplier of Electrical and Electronic Components

Click to view similar products for [FFC & FPC Connectors](#) category:

Click to view products by [TXGA](#) manufacturer:

Other Similar products are found below :

[00-6200-227-022-800](#) [006205250500825+](#) [006205280500825+](#) [FPH-1602G](#) [FPH-2022G](#) [52610-1275](#) [501864-3091-TR225](#)
[086222026001800](#) [52610-0675](#) [62674-201121DLF](#) [62684-36210E9ALF](#) [52746-1671-TR250](#) [10051922-2810EHLF](#) [686322124422](#) [XF3M-](#)
[2915-1B-R100](#) [AYF353125A](#) [AYF530665TA](#) [AYF534065TA](#) [AYF351525](#) [086212040340800+](#) [AYF530365TA](#) [67000-004LF](#)
[006207341915000+](#) [207356-1](#) [67000-003LF](#) [HFW14R-2STE9LF](#) [SFW12R-5STE9LF](#) [SFW18R-1STAE9LF](#) [SFW4R-5STE9LF](#) [52807-0430](#)
[046283021002868+](#) [502250-8027](#) [104267-9617](#) [66987-011LF](#) [HFW8S-2STAE1HLF](#) [67000-008LF](#) [HFW22R-2STE1H1LF](#) [0781271110](#)
[5019511030](#) [200528-0260](#) [5039084120](#) [503908-5120](#) [SFW20R-1STGE5LF](#) [FH12-18S-0.5SH](#) [686116183522](#) [FH64MA-11S-0.25SHW](#)
[686114183522](#) [502078-5362](#) [FH52K-68S-0.5SH](#) [FH26W-23S-0.3SHW\(60\)](#)