

REV	LOCATIONS	DESCRIPTION	DATE	REVISER	APPD
1	△	Size Changes	06/MAR/17	KATE	FRANK
2	△	Structure optimization	05/JUN/18	KATE	FRANK

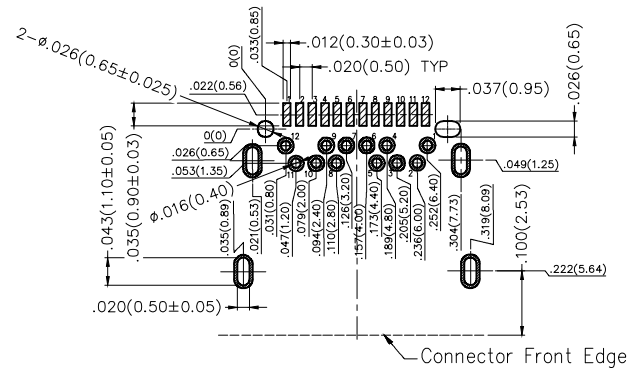
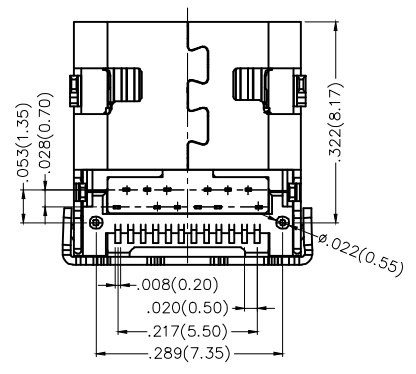
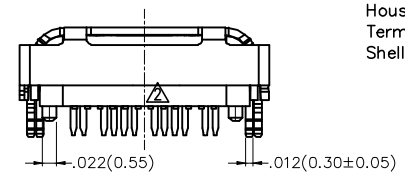
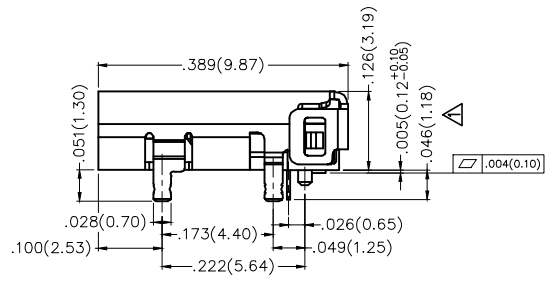
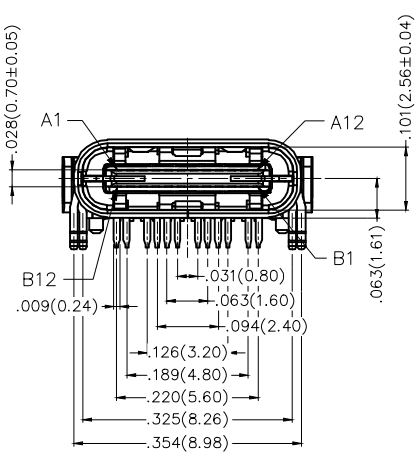
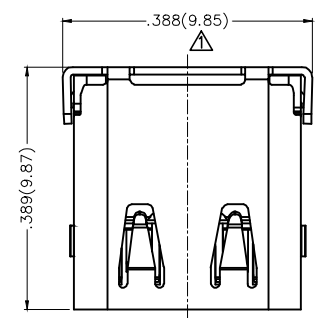

Connector Front Edge
 Recommended P.C.Board Layout T=.039(1.00)
 General Tolerances: ±.002(0.05)

SPECIFICATIONS

Electrical
 Current Rating: 5A AC(rms)/DC Max. (VBUS/GND)
 1.25A AC(rms)/DC Max. (VCONN)
 0.25A AC(rms)/DC Min. (Signal pins contact)
 Voltage Rating: 30V AC(rms)/DC
 Contact Resistance: 40 mΩ Max. (VBUS/GND)
 50 mΩ Max. (Others)
 Withstanding Voltage: 100V AC r.m.s
 Insulation Resistance: 100 MΩ Min.
 Temperature Range-Operating: -30°C~+85°C

Mechanical
 Insertion Force: 5~20N
 Withdrawal Force: 8~20N(0~1,000 cycles)
 5~20N(1,000~10,000 cycles)
 Durability: 10,000 cycles

Material and Plating
 Housing: Thermoplastic (UL 94V-0) Black
 Terminal: Copper alloy/ Gold plated
 Shell: Stainless steel/ Nickel plated

Circuits	A	Circuits	B
1	GND	12	GND
2	SSTXP1	11	SSRXP1
3	SSTXN1	10	SSRXN1
4	VBUS	9	VBUS
5	CC1	8	SBU2
6	DP1	7	DN2
7	DN1	6	DP2
8	SBU1	5	CC2
9	VBUS	4	VBUS
10	SSRXN2	3	SSTXN2
11	SSRXP2	2	SSTXP2
12	GND	1	GND

<p>THIRD ANGLE PROJECTION</p>	GENERAL TOLERANCES (UNLESS SPECIFIED)		APPROVE BY	DATE	PART NO.	ITEM NO.	<p>Leader Of Industry</p>
	X.±.012(0.30)	X.±5'	FRANK	18/JUN/13	FUS601-FSDBK6M	FUS601	
	X.X±.008(0.20)	.X'±2'	CHECKED BY	DATE	TITLE		
	X.XX±.006(0.15)	.XX'±1'	CHERRY	18/JUN/13	USB C-type 90° Angle Female(SMT+DIP)(3.1)		
SCALE	SIZE	X.XXX±.004(0.10)	.XXX'±.5'	DRAWN BY	DATE	THIS DRAWING CONTAINS INFORMATION THAT IS PROPRIETARY TO TXGA INDUSTRIAL ELECTRONICS(S.Z)CO.,LTD AND SHOULD NOT BE USED WITHOUT WRITTEN PERMISSION	
5:1	A4			KATE	18/JUN/13	REV 2	SHEET NO. 1/1

X-ON Electronics

Largest Supplier of Electrical and Electronic Components

Click to view similar products for [USB Connectors](#) category:

Click to view products by [TXGA](#) manufacturer:

Other Similar products are found below :

[10033527-N3112MLF](#) [17-210561](#) [GMCB05B11124H1EU](#) [17-200931](#) [65-647-8-BK-BU](#) [690-010-295-484](#) [73725-1191BLF](#) [950](#) [E8144-B01021-L](#) [A-USB A-LP-SMT-C](#) [A-USB B-TOP-C](#) [MUSBA511N5](#) [MUSBB15131](#) [MUSBC111M5](#) [MUSBD11135](#) [217450-1](#) [CA 6 W LD](#)
[896-30-004-00-000000](#) [KUSBVX-BS1N-W30](#) [KUSBX-AP-KIT-SCBLK](#) [KUSBX-AS2N-W](#) [KUSBX-SMT2AP1S-W](#) [KUSBX-SMTAS1NBTR](#) [KUSBX-SMTBS1NBTR](#) [30-498-6](#) [SK-60A-2](#) [17-200261](#) [17-210051](#) [1734082-1](#) [FK-37-32SL](#) [30-1574](#) [30-470](#) [30-489](#) [30-541](#) [30-572-3](#) [30-9503](#) [M9177/2-1](#) [MAB 5 S](#) [MIKROE-1451](#) [33UBBR-04SW11R](#) [USBFTV2PEM2G](#) [USBFTVC6ZN](#) [USBFTVSCCG](#)
[KUSBX-AS2N-W30](#) [KUSBX-SLAS1N-W](#) [KUSBX-SLAS1N-W30](#) [1-1734084-2](#) [E8110-001-01](#) [MUSBC11135](#) [NK-27-32SL](#)