

REV	LOCATIONS	DESCRIPTION	DATE	REVISER	APPD
1	△	Dimension $\phi.065(\phi 1.65)$ Change to $\phi.071(1.80)$	20150919	CHERRY	FAN
2	△	Structure change	20200103	CHERRY	FRANK

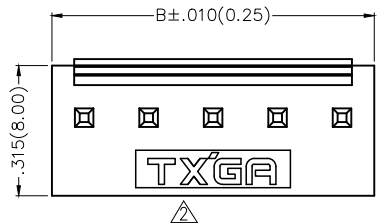

Electrical
 Current Rating: 7A AC(rms)/DC
 Voltage Rating: 250V AC(rms)/DC
 Contact Resistance: 10 m Ω Max
 Insulation Resistance: 1000 M Ω MIN
 Withstanding Voltage: 1500V AC r.m.s
 Temperature Range—Operating: -40°C~+85°C

Material and Plating
 Housing: PA6T(UL 94V-0)/PA66(UL 94V-0)
 Contact Pin: Brass
 Plating: Tin Plated

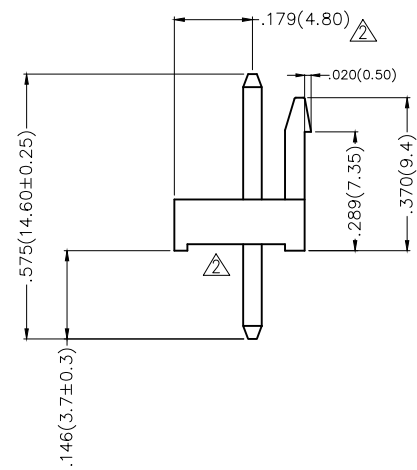
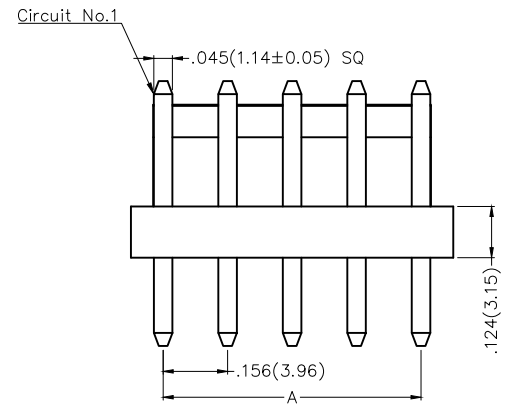

Ordering Information

FWF 396 01 — S XX S 2 2 W1 B
 1 2 3 4 5 6 7 8 9 10

1 Category FWF—Wafer	2 Series Number 396—Pitch 3.96mm	3 Distinction No. 01	4 Row Option S—Single Row	5 Circuits XX	6 Entry Angle S—180° Vertical
7 Plating 2—Tin Plated	8 Material—Resin 2—PA66	9 Color—Resin W1—White K6—Black R1—Red	10 Packaging B—PE Bag		

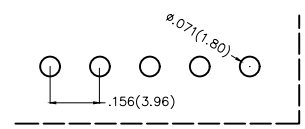

Recommended P.C.Board Layout

 THIRD ANGLE PROJECTION	GENERAL TOLERANCES (UNLESS SPECIFIED)		APPROVE BY FRANK	DATE 19/SEP/15	PART NO. FWF39601—SXXS22XXB	ITEM NO. FWF39601	 Leader Of Industry		
	DESIGN UNITS Inch (metric)	X.±.012(0.30) X.X±.008(0.20) X.XX±.006(0.15) X.XXX±.004(0.10)	X.'±5' 'X'±2' .XX'±1' .XXX'±0.5'	CHECKED BY CHERRY	DATE 19/SEP/15	TITLE Wire to Board (Wafer) Pitch 3.96mm 180° Vertical (DIP)		REV 1	SHEET NO. 1/2
	SCALE 5:1	SIZE A4		DRAWN BY JACOB	DATE 19/SEP/15	THIS DRAWING CONTAINS INFORMATION THAT IS PROPRIETARY TO TXGA INDUSTRIAL ELECTRONICS(S.Z)CO.,LTD AND SHOULD NOT BE USED WITHOUT WRITTEN PERMISSION			

REV	LOCATIONS	DESCRIPTION	DATE	REVISER	APPD
1	△	Dimension $\phi.065(\phi 1.65)$ Change to $\phi.071(1.80)$	20150919	CHERRY	FAN
2	△	Structure change	20200103	CHERRY	FRANK

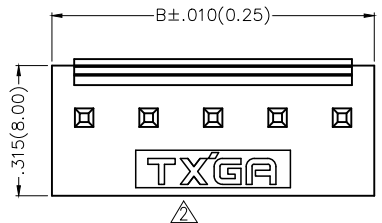

Electrical
 Current Rating: 7A AC(rms)/DC
 Voltage Rating: 250V AC(rms)/DC
 Contact Resistance: 10 m Ω Max
 Insulation Resistance: 1000 M Ω MIN
 Withstanding Voltage: 1500V AC r.m.s
 Temperature Range—Operating: -40°C~+85°C

Material and Plating
 Housing: PA6T(UL 94V-0)/PA66(UL 94V-0)
 Contact Pin: Brass
 Plating: Tin Plated

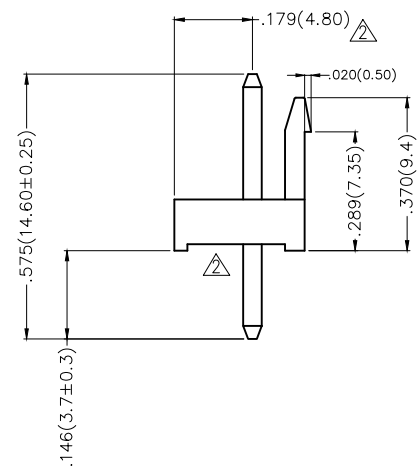
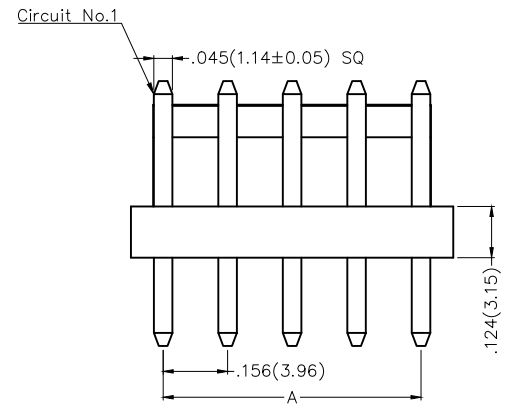

Ordering Information

FWF 396 01 — S XX S 2 X XX B
 1 2 3 4 5 6 7 8 9 10

1 Category FWF—Wafer	2 Series Number 396—Pitch 3.96mm	3 Distinction No. 01	4 Row Option S—Single Row	5 Circuits XX	6 Entry Angle S—180° Vertical
7 Plating 2—Tin Plated	8 Material—Resin 2—PA66 4—PA6T	9 Color—Resin W1—White W5—White	10 Packaging B—PE Bag		

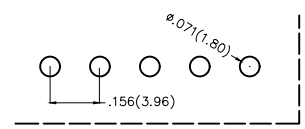



Recommended P.C.Board Layout

 THIRD ANGLE PROJECTION	GENERAL TOLERANCES (UNLESS SPECIFIED)		APPROVE BY FRANK	DATE 19/SEP/15	PART NO. FWF39601—SXXS2XXXB	ITEM NO. FWF39601	 Leader Of Industry	
	X.±.012(0.30)	X.'±5'	CHECKED BY CHERRY	DATE 19/SEP/15	TITLE Wire to Board (Wafer) Pitch 3.96mm 180° Vertical (DIP)			REV 1
	DESIGN UNITS Inch (metric)	X.X±.008(0.20)	X'±2'	DRAWN BY JACOB	DATE 19/SEP/15	THIS DRAWING CONTAINS INFORMATION THAT IS PROPRIETARY TO TXGA INDUSTRIAL ELECTRONICS(S.Z)CO.,LTD AND SHOULD NOT BE USED WITHOUT WRITTEN PERMISSION		
	SCALE 5:1	SIZE A4	X.XX±.006(0.15)	X.XX±1'				

REV	LOCATIONS	DESCRIPTION	DATE	REVISER	APPD
1	△	Dimension $\phi.065(\phi 1.65)$ Change to $\phi.071(1.80)$	20150919	CHERRY	FAN

Material and Plating : Housing PA66 UL94V-0 , Tin-Plated.				Material and Plating : Housing PA6T UL94V-0 , Tin Plated.			
Circuits (n)	Part No.	Dimensions(in/mm)		Circuits (n)	Part No.	Dimensions(in/mm)	
		A	B			A	B
2	FWF39601-S02S22W1B	.156(3.96)	.311(7.92)	2	FWF39601-S02S24W5B	.156(3.96)	.311(7.92)
3	FWF39601-S03S22W1B	.311(7.92)	.468(11.88)	3	FWF39601-S03S24W5B	.311(7.92)	.468(11.88)
4	FWF39601-S04S22W1B	.468(11.88)	.624(15.84)	4	FWF39601-S04S24W5B	.468(11.88)	.624(15.84)
5	FWF39601-S05S22W1B	.624(15.84)	.780(19.80)	5	FWF39601-S05S24W5B	.624(15.84)	.780(19.80)
6	FWF39601-S06S22W1B	.780(19.80)	.935(23.76)	6	FWF39601-S06S24W5B	.780(19.80)	.935(23.76)
7	FWF39601-S07S22W1B	.935(23.76)	1.091(27.72)	7	FWF39601-S07S24W5B	.935(23.76)	1.091(27.72)
8	FWF39601-S08S22W1B	1.091(27.72)	1.247(31.68)	8	FWF39601-S08S24W5B	1.091(27.72)	1.247(31.68)
9	FWF39601-S09S22W1B	1.247(31.68)	1.403(35.64)	9	FWF39601-S09S24W5B	1.247(31.68)	1.403(35.64)
10	FWF39601-S10S22W1B	1.403(35.64)	1.559(39.60)	10	FWF39601-S10S24W5B	1.403(35.64)	1.559(39.60)
11	FWF39601-S11S22W1B	1.559(39.60)	1.715(43.56)	11	FWF39601-S11S24W5B	1.559(39.60)	1.715(43.56)
12	FWF39601-S12S22W1B	1.715(43.56)	1.871(47.52)	12	FWF39601-S12S24W5B	1.715(43.56)	1.871(47.52)

 THIRD ANGLE PROJECTION	GENERAL TOLERANCES (UNLESS SPECIFIED)		APPROVE BY FRANK	DATE 19/SEP/15	PART NO. FWF39601-SXXS2XXXB	ITEM NO. FWF39601	 Leader Of Industry	
	DESIGN UNITS Inch (metric)	X. \pm .012(0.30)	X. \pm 5'	CHECKED BY CHERRY	DATE 19/SEP/15	TITLE Wire to Board (Wafer) Pitch 3.96mm 180° Vertical (DIP)		REV 2
SCALE 5:1	SIZE A4	X.XX \pm .006(0.15)	.XX \pm 1'	DRAWN BY JACOB	DATE 19/SEP/15	THIS DRAWING CONTAINS INFORMATION THAT IS PROPRIETARY TO TXGA INDUSTRIAL ELECTRONICS(S.Z)CO.,LTD AND SHOULD NOT BE USED WITHOUT WRITTEN PERMISSION		
		X.XXX \pm .004(0.10)	.XXX \pm 0.5'					

X-ON Electronics

Largest Supplier of Electrical and Electronic Components

Click to view similar products for [Headers & Wire Housings](#) category:

Click to view products by [TXGA](#) manufacturer:

Other Similar products are found below :

[0015917161](#) [0022155065](#) [57102-F02-18ULF](#) [58102-G61-06LF](#) [582553-1](#) [01.001.5753.1](#) [0050291907](#) [02.125.8002.8](#) [609-3404](#) [61062-3](#)
[CSU011177004](#) [622-0430](#) [622-3653LF](#) [63453-116](#) [636-1030](#) [636-1427](#) [636-3427](#) [636-4007](#) [641938-9](#) [65495-038](#) [65692-001LF](#) [65781-018](#)
[65781-047](#) [65817-010LF](#) [65817-015LF](#) [67095-007LF](#) [67601157](#) [68631-112](#) [68645-018](#) [699319-000](#) [70.362.1628.0](#) [70-4210](#) [70-4226B](#) [70-](#)
[4853B](#) [71.350.2428.0](#) [733-134](#) [733-162](#) [760-3052](#) [MHR-64-VUAL](#) [80.063.4001.1](#) [800-90-001-10-001000](#) [801-43-002-10-013000](#)
[801-43-006-10-002000](#) [803-43-024-10-001000](#) [803-93-012-10-001000](#) [8-1437020-4](#) [819-22-004-30-001101](#) [820-22-006-30-001101](#)
[820-22-008-30-001101](#) [821-22-002-10-001101](#)