



Document No.:S-E05

TY-OHM ELECTRONIC WORKS CO.,LTD.

WIRE WOUND RESISTORS, FLAMEPROOF/RESIN PAINT RESISTOR SPECIFICATION

Version : 2022.A

APPROVED BY

--

APPROVED	REVIEWED	PREPARED
<i>Jack kw</i> <i>Jan 25, 2022</i>	<i>Jack kw</i> <i>Jan 25, 2022</i>	<i>Rob Lo</i> <i>Jan 25, 2022</i>

WIRE WOUND RESISTORS, FLAMEPROOF/RESIN PAINT

1. Applicable Scope:

This standard specification is for use in consumer electronics, computers, telecommunications, control instruments...etc.

2. Part Number:

It is composed by Type, Terminal Form, Rated Wattage, Nominal Resistance, Tolerance and Package/Forming Style. e.g.

<u>KN</u>	<u>P</u>	<u>1W</u>	<u>10R</u>	<u>J</u>	<u>T/B</u>
Type	Terminal Form	Rated Wattage	Nominal Resistance	Tolerance	Package/Forming Style

2.1 Type :

Wire Wound Resistors, Flameproof/Resin Paint are called "KN".

2.2 Terminal Form:

Upon the shape of terminal, there are "P" form, "Y" form and "H" form.

2.3 Rated Wattage:

Shown by "W", such as 1/4W, 1/2W, 1W, 2W, 3W, 3WL, 5W, 6W, 7W, 8W, 10W...

2.4 Nominal Resistance:

Ω , $K\Omega$ are its unit, which be in accordance with E24 series or E96 series.

Letter "10R" indicates resistance value 10Ω .

2.5 Tolerance:

It is measured by Bridge-method at room temperature and expressed by a capital letter.

F = $\pm 1\%$, G = $\pm 2\%$, J = $\pm 5\%$, K = $\pm 10\%$.

2.6 Package/Terminal Form:

T/B = Standard tape in box; T/R = Standard tape & reel; Nil = Bulk.

T52 = 52 mm width special tape in box; T63 = 63 mm width special tape in box.

R52 = 52 mm width special tape & reel; R63 = 63 mm width special tape & reel

F1~F4 form; MG form.

Letter "PA" indicates radial type lead taping.

※Remark: KN Series Resistors are RoHS & Halogen Free Compliant.

WIRE WOUND RESISTORS, FLAMEPROOF/RESIN PAINT

3. Rated Power:

Rated power is the value of Max load power specified at the ambient temperature of 70°C, and shall meet the functions of electrical and mechanical performance. When the ambient temperature surpasses above mentioned temperature, the value declines as per following DERATING CURVE.

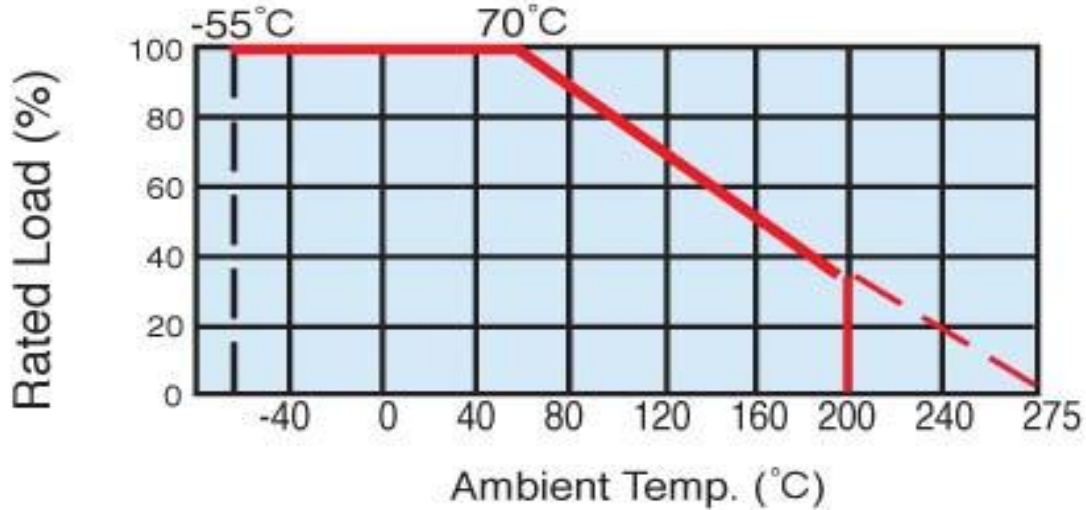

3.1 Rated Voltage:

It is calculated through the following formula:

$$E = \sqrt{P \times R}$$

where E: rated voltage (V)
P: rated power (W)
R: total nominal resistance (Ω)

WIRE WOUND RESISTORS, FLAMEPROOF/RESIN PAINT

4. Dimension and structure:

4.1 Dimension:

4.1.1 KNP TYPE:



unit : mm

TYPE	$D \pm 1$	$L \pm 1$	$H \pm 3$	$d \pm 0.1$	Resistance Range (Ω)	Dielectric Withstanding Voltage
KNP						
1/4W	2.6 ± 0.5	6.8	28	0.6	0.1 ~ 200	250V
1/2W	3	9	28	0.65	0.1 ~ 300	350V
1W	4	9	28	0.65	0.1 ~ 500	350V
2W	5	11	28	0.8	0.1 ~ 1K	500V
3W	5.5	13	38(Package: T/B) 28(Package: T63)	0.8	0.1 ~ 1K	500V
3WL	5.5	15	38(Package: T/B) 28(Package: T63)	0.8	0.1 ~ 1.2K	500V
5W	6.5	19	38	0.8	0.1 ~ 1.2K	500V
6W	8.5	24	38	0.8	0.1 ~ 1.5K	500V
7W	8.5	32	33	0.8	0.1 ~ 1.5K	500V
8W	8.5	41	38	0.8	0.1 ~ 2.2K	800V
10W	8.5	53	38	0.8	0.1 ~ 3.3K	1000V

© Notes: Too low or too high ohmic values can be supplied only case by case.

WIRE WOUND RESISTORS, FLAMEPROOF/RESIN PAINT

4.1.2 KNY :

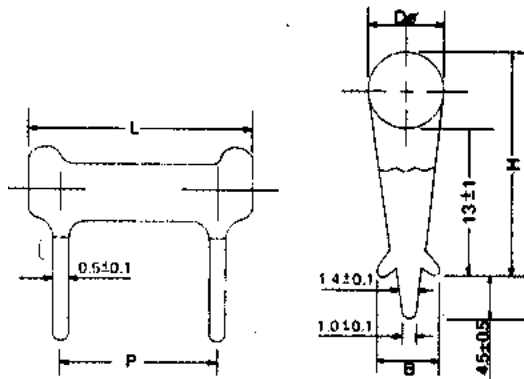

Unit: mm

TYPE	D±1	L±1.5	P±1.5	H±1	B±0.5	Resistance Range	Dielectric Withstanding Voltage
KNY							
5W	8.5	25	15	21.5	6.5	0.5Ω ~390Ω	500V
7W	8.5	32	22	21.5	6.5	0.5Ω ~1.5KΩ	800V
10W	8.5	53	42.5	21.5	6.5	0.5Ω ~2.2KΩ	1000V

4.1.3 KNH :

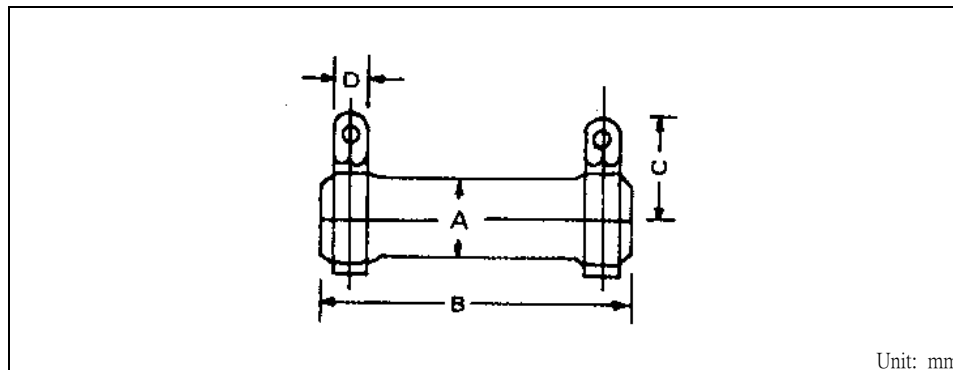

Unit: mm

TYPE	A±1.5	B±1.5	C±3	D±0.5	Resistance Range
KNH					
10W	11	45	20	5	0.5Ω ~3KΩ
15W	15.5	45	20	4.5	1Ω ~5KΩ
20W	20	50	22	5	1Ω ~10KΩ
25W	20	60	22	5	1Ω ~12.5KΩ
30W	20	75	22	6	2Ω ~15KΩ
40W	20	90	22	6	2Ω ~20KΩ
50W	28	75	32	8	3Ω ~25KΩ
60W	28	90	32	8	3Ω ~30KΩ
80W	28	115	32	8	3Ω ~40KΩ
100W	28	140	32	8	4Ω ~50KΩ
120W	28	165	32	8	4Ω ~60KΩ
150W	28	195	32	8	5Ω ~75KΩ
200W	28	254	32	8	5Ω ~100KΩ
300W	42	254	45	10	5Ω ~100KΩ
400W	42	330	45	10	10Ω ~100KΩ
600W	42	420	45	10	10Ω ~100KΩ

WIRE WOUND RESISTORS, FLAMEPROOF/RESIN PAINT

4.2 STRUCTURE:

4.2.1 Ceramic Rod:

It is made of alumina ceramic of the kind.

4.2.2 Terminal:

Terminal is to be firmly connected with resistors element, both electrically and mechanically, and allow easy soldering.

4.2.3 Coating:

Coating is done by green flameproof paint (resistant to 800°C) or Silicon Resin which is solid enough to be free from looseness, crack and easy breakage. It is also resistant to cleaning and industrial solvents, and the paint shall be limited within 2mm of lead wires from resistor body.

4.2.4 Marking:

Marking is made on resistors surface, either by color coding or marked with Type of Resistor, Rated Wattage, Nominal Resistance, Tolerance and Maker's trade mark (TY-OHM).

5. Operating Temperature Range: -55°C ~ 200°C

6. Mechanical Performance:

6.1 Terminal tensile:

To fix the resistor body, a static load of 2.5kg. (1W:1kg.) is to be gradually applied into the terminal for 10 seconds without causing any looseness and fall.

6.2 Twist withstand:

To bend the lead wire at the point of about 6mm from resistor body to 90°, then catch the wire at 1.2±0.4mm apart from the bent point end and turn it (clockwise) by 360 degrees perpendicular to the resistor axis at speed of 10 seconds per turn, and do the same counterclockwise again which constitute a whole turn. Repeat the turn 2 times without causing any break and looseness.

7. Electrical Performance:

7.1 Resistance Temperature Coefficient:

It shall be within ±300ppm/°C. (under 1Ω shall be within ±500ppm/°C)

$$T.C \text{ (ppm/°C)} = \left[\frac{R_2 - R_1}{R_1} \right] \times \left[\frac{1}{T_2 - T_1} \right] \times 10^6$$

where

R1: resistance value at reference temperature

R2: resistance value at test temp.

T1: reference temp.

T2: test temp.

7.2 Temperature Cycle:

Following temp. cycles are to be made 5 times and then put at room temp. for one hour, the resistance value change rate between pre-and-post test shall be within ±1%.

Steps	Temperature(°C)	Time (minutes)
1 st step	-55±3	30
2 nd step	Room temp.	3
3 rd step	200±3	30
4 th step	Room temp.	3

WIRE WOUND RESISTORS, FLAMEPROOF/RESIN PAINT

7.3 Short Time Over Load:

When the resistors are applied 10 times as much as rated power for 5 seconds continuously, it shows no evidence of arc, flame...etc. Removing the voltage and place the resistors to the normal condition for 30 minutes, the resistance value change rate between pre-and-post test shall be within $\pm 2\%$.

7.4 Insulation Character :

Resistors are located in a V-shaped metal trough. Using the DC 100V or 500V megger instrument 2 poles to clutch either side of lead wires and metal trough, measuring the Insulation Resistance which shall be over $1000M\Omega$.

7.5 Voltage Withstanding:

Resistors are located in a V-shaped metal trough. Applying suitable voltage listed on DIMENSION for one minute and should find no physical damage to the resistors, such as arc, char...etc.

7.6 Load Life:

The resistors arrayed are sent into the 70°C oven, applying rated voltage at the cycle of 1.5 hours ON, 0.5 hour OFF for 1000_{-0}^{+48} hours in total. Then, after removing the voltage, take the resistors out of the oven and left under normal temp. for one hour cooling. The resistance value change rate between pre-and-post test shall be within $\pm 3\%$.

7.7 Moisture-proof Load Life:

The resistors arrayed are placed into a constant temp./humidity oven at the temp. of $40 \pm 2^{\circ}\text{C}$ and the humidity of 90~95%, then 1/10 DC rated power is applied for 1.5 hours and cut off for 0.5 hour. The similar cycle will be repeated for 1000_{-0}^{+48} hours in total (including cut-off time). Then remove the voltage, taking the resistors out of the oven and leaving them at room temp. for one hour. The resistance value change rate between pre-and-post test shall be within $\pm 3\%$. There also shall be no evidence of remarkable change on appearance, and the marking shall not be illegible.

7.8 Solder-ability:

The leads with flux are dipped in a melted solder of $235 \pm 5^{\circ}\text{C}$ for 2 seconds, more than 95% of the circumference of the lead wires shall be covered with solder.

7.9 Resistance to Soldering Heat:

Two leads are together dipped in a melted solder of $270 \pm 5^{\circ}\text{C}$ for 10 ± 1 seconds, or $350 \pm 10^{\circ}\text{C}$ for 3.5 ± 0.5 seconds, Then remove the resistors and leaving them at room temp. for one hour. The resistance value change rate between pre-and-post test shall be within $\pm 1\%$.

7.10 Nonflammability:

The resistors are applied the power of 16 times the rated wattage for 5 min. and shall not get flame.

WIRE WOUND RESISTORS, FLAMEPROOF/RESIN PAINT

8.Others:

8.1 MG Form:

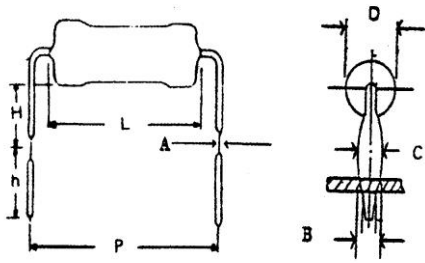

Unit: mm

KNP	L±1	D±1	P	H	h±1	A±0.02	B±0.05	C±0.2
1/2W	9	3	12.5±1.5	7±1	4.5	0.23	0.8	1.2
1W	9	4	15±1.5	7±1	4.5	0.23	0.8	1.2
2W	11	5	15±1.5	7±1	4.5	0.25	1	1.4
3W	13	5.5	20±2	10±2	4.5	0.25	1	1.4
3WL	15	5.5	20±2	10±2	4.5	0.25	1	1.4

8.2 F Form:

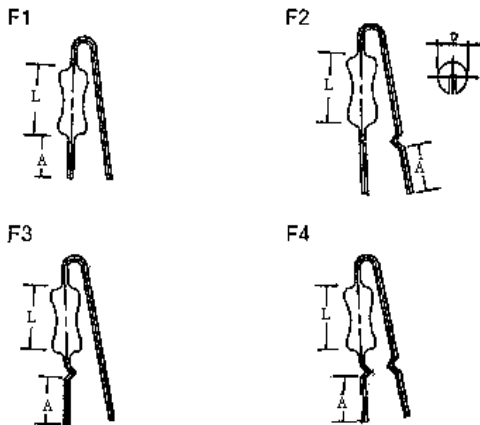

Unit: mm

KNP	L±1	D±1	A+1/-0.5	APPLICABLE
1/2W	9	3	3.5	F1~F4
1W	9	4	3.5	F1~F4
2W	11	5	3.5	F1~F4
3WL	15	5.5	3.5	F1~F4

WIRE WOUND RESISTORS, FLAMEPROOF/RESIN PAINT

8.3 Package:

8.3.1 Taping Specifications:

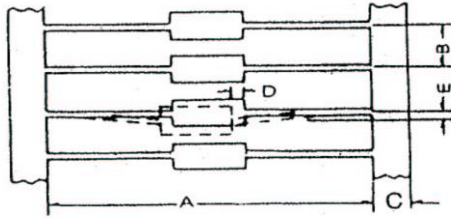

Unit: mm

KNP	Package	A	B	C±1	D Max	E Max
≤1W	T/B, T/R	52±1	5±0.5	6	0.5	1.2
1W	T63	63±1	5±0.5	6	0.5	1.2
2W	T52, R52	52 ±1	5±0.5	6	0.5	1.2
	T/B, T/R	63±1	5±0.5	6	0.5	1.2
3W	T63, R63	63± 1	10±1	6	0.6	1.2
3WL	T/B, T/R	76±1.5	10±1	6	0.5	1.2
5W	T/B	82±1.5	10±1	6	0.6	1.2
6W	T/B	93±1.5	10±1	6	0.6	1.2

8.3.2 Tape in Box:

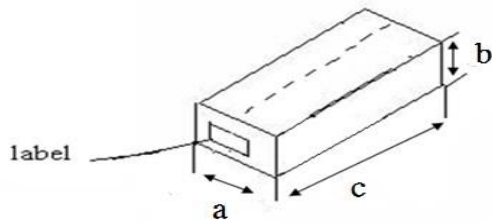

Unit: mm

KNP	Package	QTY PER BOX	a	b	c
1/2W	T/B	1,000	75	55	255
1W	T/B	1,000	75	55	255
1W	T63	1,000	90	58	267
2W	T52	1,000	75	100	255
	T/B	1,000	85	105	260
3W	T63	1,000	100	110	265
3WL	T/B	1,000	106	110	265
5W	T/B	500	98	95	270
6W	T/B	200	148	77	270

WIRE WOUND RESISTORS, FLAMEPROOF/RESIN PAINT

8.3.3 Tape & Reel:

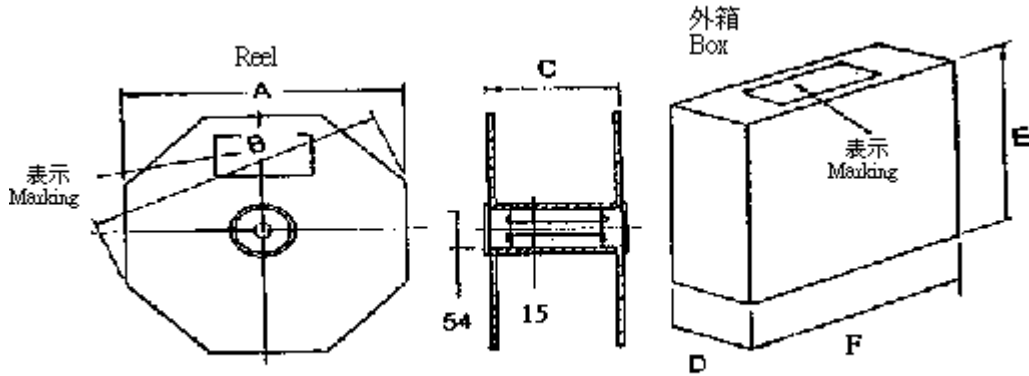

Unit:mm

KNP	Package	QTY PER REEL	A	B	C	D	E	F
1/2W	T/R	5,000	305	330	75	90	310	310
1W	T/R	2,500	285	310	75	80	295	295
2W	R52	2,000	285	310	75	95	295	295
	T/R	2,000	285	310	75	95	295	295
3W	R63	1,000	285	310	90	105	295	295
3WL	T/R	1,000	285	310	90	105	295	295
5W	T/R	1000	285	310	110	120	295	295
6W	T/R	500	285	310	110	120	295	295

WIRE WOUND RESISTORS, FLAMEPROOF/RESIN PAINT

8.3.4 Radial type lead taping(PA):

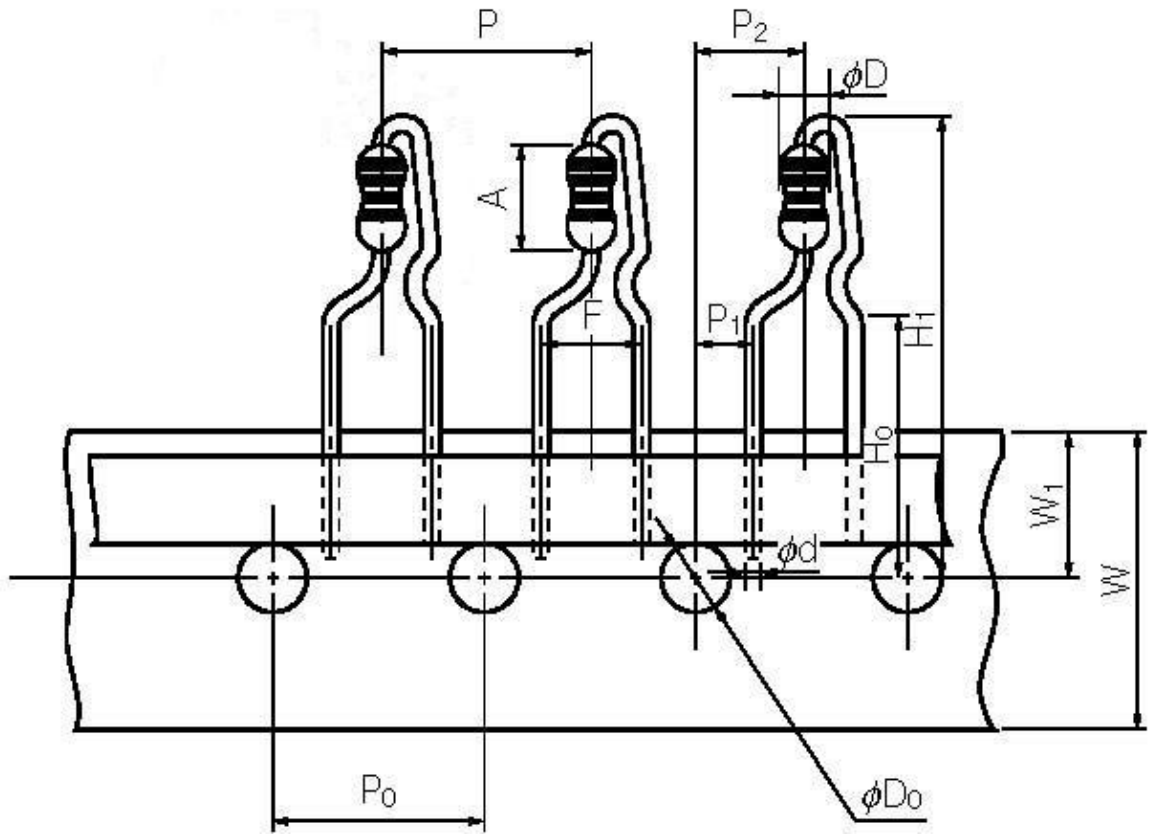

Unit: mm

KNP	P ± 1	P_0 ± 0.3	P_1 ± 0.7	P_2 ± 1	F ± 0.8	W ± 0.5	W_1 ± 0.5	H_1 max	H_0 ± 0.5	ϕD_0 ± 0.2	A ± 1	ϕd ± 0.1	ϕD ± 1	REMARK
1W	12.7	12.7	3.85	6.35	5	18	9	32	16	4	9	0.65	4	
2W	12.7	12.7	3.85	6.35	5	18	9	38	16	4	11	0.8	5	
3W	12.7	12.7	3.85	6.35	5	18	9	38	16	4	13	0.8	5.5	
3WL	12.7	12.7	3.85	6.35	5	18	9	38	16	4	15	0.8	5.5	

X-ON Electronics

Largest Supplier of Electrical and Electronic Components

Click to view similar products for [Thick Film Resistors - Through Hole](#) category:

Click to view products by [Tyohm](#) manufacturer:

Other Similar products are found below :

[M8340104K3300GCD03](#) [M8340105K3300GGD03](#) [M8340105K3922FGD03](#) [M8340107K2401GCD03](#) [M8340109K1002JCD03](#)
[M8340109K1003GCD03](#) [MP850-3.00-1%](#) [ARC3.11 2M J A](#) [M8340105K1003GCD03](#) [M8340105M2201GCD03](#) [M8340107M7501GCD03](#)
[M8340108K2051FCD03](#) [M8340108K7501GCD03](#) [M8340108M5100JGD03](#) [M8340109K1000GCD03](#) [MOX-GRD-001](#)
[M8340102M4701GBD04](#) [M8340102K1002GBD04](#) [M8340109K2002GGD03](#) [M8340108K2002FGD03](#) [OE1305](#) [MS-221-82R5](#) [MOX-](#)
[750231004DE](#) [MOX-4-127505J](#) [SM102034504FE](#) [MOX300002206FE](#) [MOX-400233004F](#) [MOX300001005BE](#) [SM104066008J](#) [MOX-](#)
[400262008PE](#) [MOX-400232506FE](#) [MOX-400234007FE](#) [MOX-400221006G](#) [MOX-750235006ME](#) [SM103032506FE](#) [SM202022005FE](#)
[MOX1125231002FE](#) [MOX-1-122504F](#) [MOX-400225003F](#) [MOX1125731008FE](#) [MOX-5-126002JE](#) [MS176-2.20M-1%](#) [MOX-830212453BE](#)
[TRHE01A270RJ2E](#) [TRHE01A560RJ2E](#) [TRHP01A200RF2E](#) [TRHP01A5001F2E](#) [MG715-2.40M-1%](#) [MS214-20.0K-1%](#) [MF0W4FF4702A50](#)