



Document No.:S-E052-1110

TY-OHM ELECTRONIC WORKS CO.,LTD.

WIRE WOUND RESISTORS, FLAMEPROOF/RESIN PAINT RESISTOR SPECIFICATION

Version : 2011.D

APPROVED BY

APPROVED	REVIEWED	PREPARED
<i>Jack Luo</i> Oct 14, 2011	<i>Jack Luo</i> Oct 14, 2011	<i>Rob Lo</i> Oct 14, 2011

Unauthorized duplication is prohibited

WIRE WOUND RESISTORS, FLAMEPROOF/RESIN PAINT

1. Applicable Scope:

This standard specification is for use in consumer electronics, computers, telecommunications, control instruments...etc.

2. Part Number:

It is composed by Type, Rated Wattage, Nominal Resistance, Tolerance, Safety Version & Special Wire, Style and

Terminal Form. e.g.

KNP	1WS	10Ω	J	H2	Fuse	P-15
Type	Rated Wattage	Nominal Resistance	Tolerance	Safety Version & Special Wire	Style	Terminal Form

2.1 Type :

Wire Wound Resistors, Flameproof/Resin Paint are called "KNP".

2.2 Rated Wattage:

Shown by "W", such as 1WS.

2.3 Nominal Resistance:

Ω is its unit, which be in accordance with JIS-C6409 article 6 (EIA RS-196A) series.

2.4 Tolerance:

It is measured by Bridge-method at room temperature and expressed by a capital letter.

J=±5%.

2.5 Safety Version & Special Wire:

Letter "H2" indicate safety version & special wire.

2.6 Style:

Word "Fuse" indicates a resistor combines a thermal element.

2.7 Terminal Form:

Letter "SL" indicates straight leadwires.

Letter "P-15" indicates leadwires performing for AC-15 models.

Remark: KNP Series Resistors are RoHS Compliant.

3. Rated Power:

Rated power is the value of Max load voltage specified at the ambient temperature of 20°C, and shall meet the functions of electrical and mechanical performance. When the ambient temperature surpasses above mentioned temperature, the value declines as per following DERATING CURVE.

DERATING CURVE

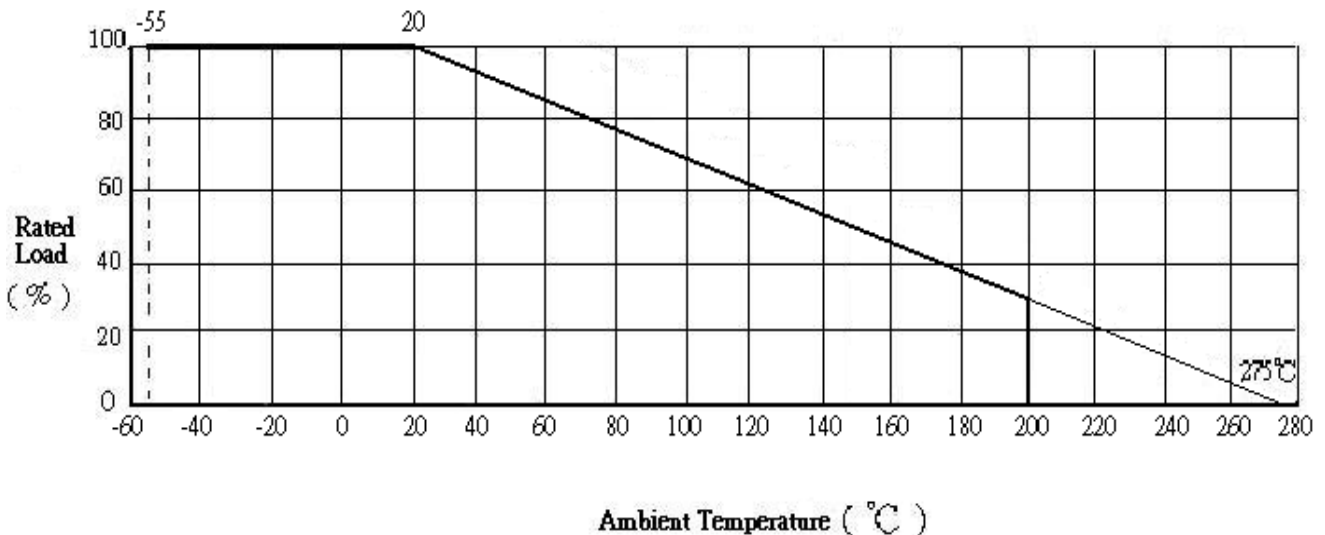

WIRE WOUND RESISTORS, FLAMEPROOF/RESIN PAINT

3.1 Rated Voltage:

It is calculated through the following formula:

$$E = \sqrt{PXR}$$

where E: rated voltage (V)
 P: rated power (W)
 R: total nominal resistance (Ω)

However, in case the voltage calculated exceeds the maximum load voltage, such the maximum load voltage shall be regarded as its rated voltage, means whichever less.

4. Dimension and structure:

4.1 Dimension for SL Form:

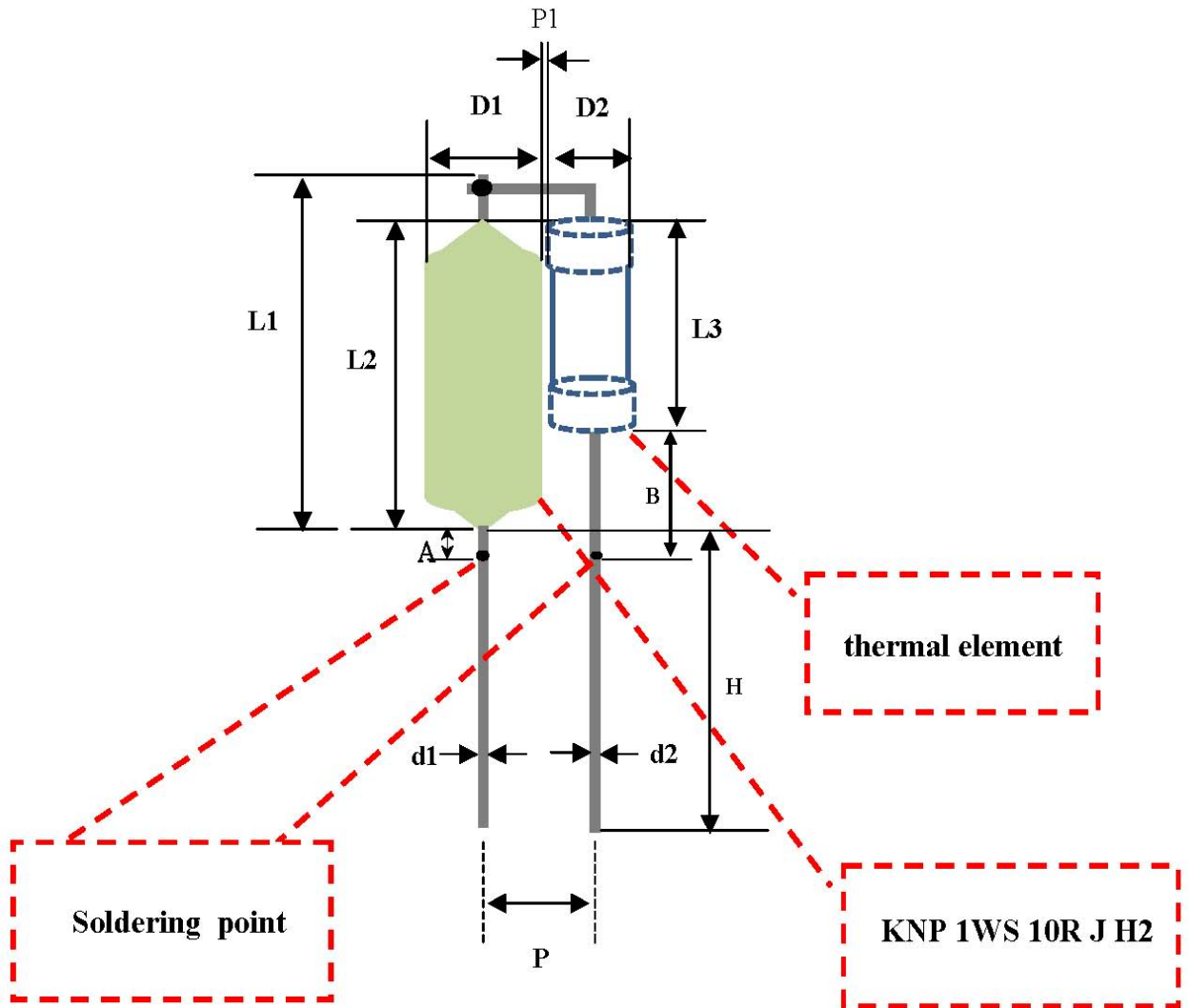

Dimension (mm)												
L1	L2	L1-L2	L3	D1	D2	d1	d2	H	P	P1	A	B
11±0.5	8.8±0.2	2.2±0.7	5.6±0.2	4.5±0.5	2.2±0.2	0.5±0.02	0.6±0.1	18±1	3.6 Ref.	※	1 Min.	1 Min.

※ The smallest distance between the resistor and the thermal element should be less than 0.7 mm.

WIRE WOUND RESISTORS, FLAMEPROOF/RESIN PAINT

4.2 Dimension for P-15 Form:

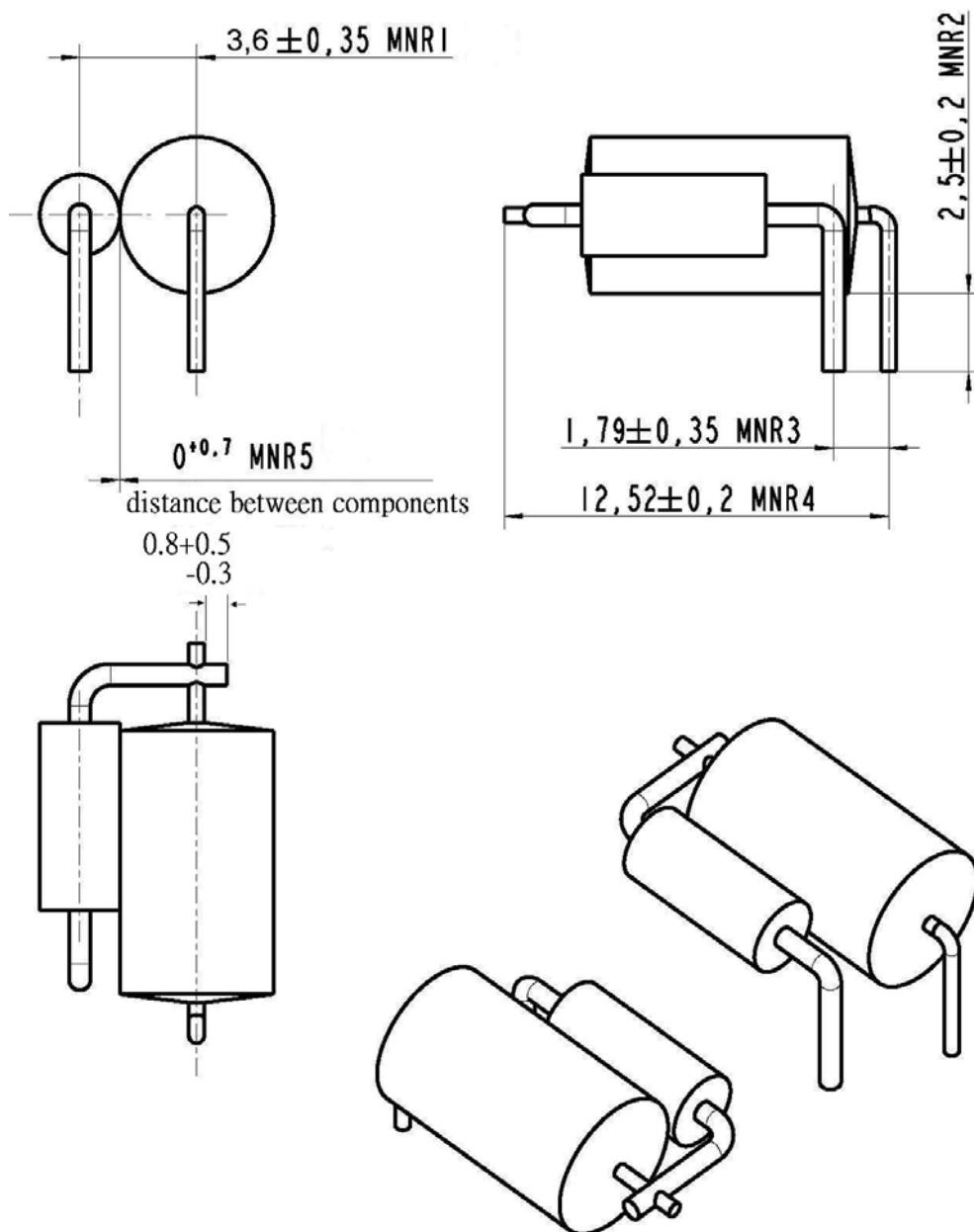

4.3 Structure:

4.3.1 Terminal:

Terminal is to be firmly connected with resistors element, both electrically and mechanically, and allow easy soldering.

4.3.2 Coating:

Coating is done by light green flameproof paint (resistant to 800°C) or Silicon Resin which is solid enough to be free from looseness, crack and easy breakage. It is also resistant to cleaning and industrial solvents, and the paint shall be limited within 1mm of lead wires from resistor body.

4.3.3 Marking:

Marking is made on resistors surface, by five color coding; 1st, 2nd, 3rd: nominal resistance, 4th: tolerance, 5th: orange color band for safety version & special wire.

WIRE WOUND RESISTORS, FLAMEPROOF/RESIN PAINT

4.3.4 Thermal element:

Two layers are separately deposited on a ceramic body: the first layer is special film with high resistance value and the second layer is pure Tin with low resistance value. Then comes to the capping & welding process in which the tin-coated lead wires are welded into the end caps.

Function Temperature(°C)	Holding Temperature(°C)	Max Working Voltage	Max Working Current
260 ± 10	200	250V	1 A

5. Operating Temperature Range: -55°C ~ 200°C

6. Mechanical Performance:

6.1 Terminal tensile:

To fix the resistor body, a static load of 1kg. is to be gradually applied into the terminal for 10 seconds without causing any looseness and fall.

6.2 Twist withstand:

To bend the lead wire at the point of about 6mm from resistor body to 90°, then catch the wire at 1.2 ± 0.4mm apart from the bent point end and turn it (clockwise) by 360 degrees perpendicular to the resistor axis at speed of 10 seconds per turn, and do the same counterclockwise again which constitute a whole turn. Repeat the turn 2 times without causing any break and looseness.

7. Electrical Performance:

7.1 Resistance Temperature Coefficient:

It shall be within +4500ppm/°C.

$$T.C \text{ (ppm/°C)} = [(R2 - R1) \div R1] \times [1 \div (T2 - T1)] \times 10^6$$

where

R1: resistance value at reference temperature

R2: resistance value at test temp.

T1: reference temp. (usu. 25°C)

T2: test temp. (about 75°C)

7.2 Temperature Cycle:

Following temp. cycles are to be made 5 times and then put at room temp. for one hour, the resistance value change rate between pre-and-post test shall be within ±1%.

Steps	Temperature(°C)	Time (minutes)
1 st step	-55 ± 3	30
2 nd step	Room temp.	3
3 rd step	200 ± 3	30
4 th step	Room temp.	3

7.3 Short Time Over Load:

When the resistors are applied 5 times as much as rated power for 5 seconds continuously, it shows no evidence of arc, flame...etc. Removing the voltage and place the resistors to the normal condition for 30 minutes, the resistance value change rate between pre-and-post test shall be within ±2%.

WIRE WOUND RESISTORS, FLAMEPROOF/RESIN PAINT

7.4 Insulation Character :

Resistors are located in a V-shaped metal trough. Using the DC 500V megger instrument 2 poles to clutch either side of lead wires and metal trough, measuring the Insulation Resistance which shall be over 1000M Ω .

7.5 Voltage Withstanding:

Resistors are located in a V-shaped metal trough. Applying AC 1000V for one minute and should find no physical damage to the resistors, such as arc, char...etc.

7.6 Load Life:

The resistors arrayed are sent into the 70°C oven, applying rated voltage at the cycle of 1.5 hours ON, 0.5 hour OFF for 1000^h hours in total. Then, after removing the voltage, take the resistors out of the oven and left under normal temp. for one hour cooling. The resistance value change rate between pre-and-post test shall be within $\pm 3\%$.

7.7 Moisture-proof Load Life:

The resistors arrayed are placed into a constant temp./humidity oven at the temp. of 40 $\pm 2^\circ\text{C}$ and the humidity of 90~95%, then 1/10 DC rated power is applied for 1.5 hours and cut off for 0.5 hour. The similar cycle will be repeated for 1000^h hours in total (including cut-off time). Then remove the voltage, taking the resistors out of the oven and leaving them at room temp. for one hour. The resistance value change rate between pre-and-post test shall be within $\pm 3\%$. There also shall be no evidence of remarkable change on appearance, and the marking shall not be illegible.

7.8 Solder-ability:

The leads with flux are dipped in a melted solder of 235 $\pm 5^\circ\text{C}$ for 2 seconds, more than 95% of the circumference of the lead wires shall be covered with solder.

7.9 Resistance to Soldering Heat: (Suitable for wave-flow and iron solderings)

7.9.1 The leads of resistor are dipped to 1mm from the body in a melted solder of 270 $\pm 5^\circ\text{C}$ for 10 ± 1 seconds, or 350 $\pm 10^\circ\text{C}$ for 3.5 ± 0.5 seconds, Then remove the resistors and leaving them at room temp. for one hour. The resistance value change rate between pre-and-post test shall be within $\pm 1\%$.

7.9.2 The leads of thermal element are dipped to 1mm from the body in a melted solder of 270 $\pm 5^\circ\text{C}$ for 10 ± 1 seconds, or 350 $\pm 10^\circ\text{C}$ for 3.5 ± 0.5 seconds, Then remove the resistors and leaving them at room temp. for one hour. The resistance value change rate between pre-and-post test shall be within $\pm 1\%$.

7.10 Non-flammability:

The resistors have to fulfill "Flexpower BREAKDOWN TEST 1" and " Flexpower BREAKDOWN TEST 2". No flames, no explosion, no sound and no arc happened.

7.11 Fusing Characteristics:

The resistors will fuse when mains voltage of 80 VAC (minimum) ~ 420 VAC (maximum) is directly applied for 5 seconds maximum. No flames, no explosion, no sound and no arc happened. The resistance value after fusing shall be over 2Mohm.

7.12 Surge Withstanding:

The resistors are designed to withstand 2kV (minimum) ~ 3kV (maximum) 1.2/50 μs pulse according to IEC61000-4-5, 30 pulses per voltage, 10 seconds between each pulse. Starting voltage is 500V then 1kV; 1.5kV and finally 2kV.

The resistance value change rate between pre-and-post test shall be within $\pm 5\%$.

WIRE WOUND RESISTORS, FLAMEPROOF/RESIN PAINT

7.13 Inrush Current Withstanding:

The resistors are designed to withstand the inrush current requirements as following:

A. Apply 400VDC, change the shunt resistor between 0 and 60hm to get the maximum current 33A. Repeat this pulse 10000 times with 10seconds break between each pulse. The 33A should be guaranteed for the temperature range between -55°C to 200°C.

Take new samples

B. Apply 500VDC, change the shunt resistor between 0 and 60hm to get the maximum current 42A. Repeat this pulse 5000 times with 10seconds break between each pulse. The 42A should be guaranteed for the temperature range between -55°C to 200°C.

Take new samples

C. Apply 594VDC, change the shunt resistor between 0 and 60hm to get the maximum current 50A. Repeat this pulse 1000 times with 10seconds break between each pulse. The 50A should be guaranteed for the temperature range between -55°C to 200°C.

The resistance value change rate between pre-and-post test shall be within $\pm 5\%$.

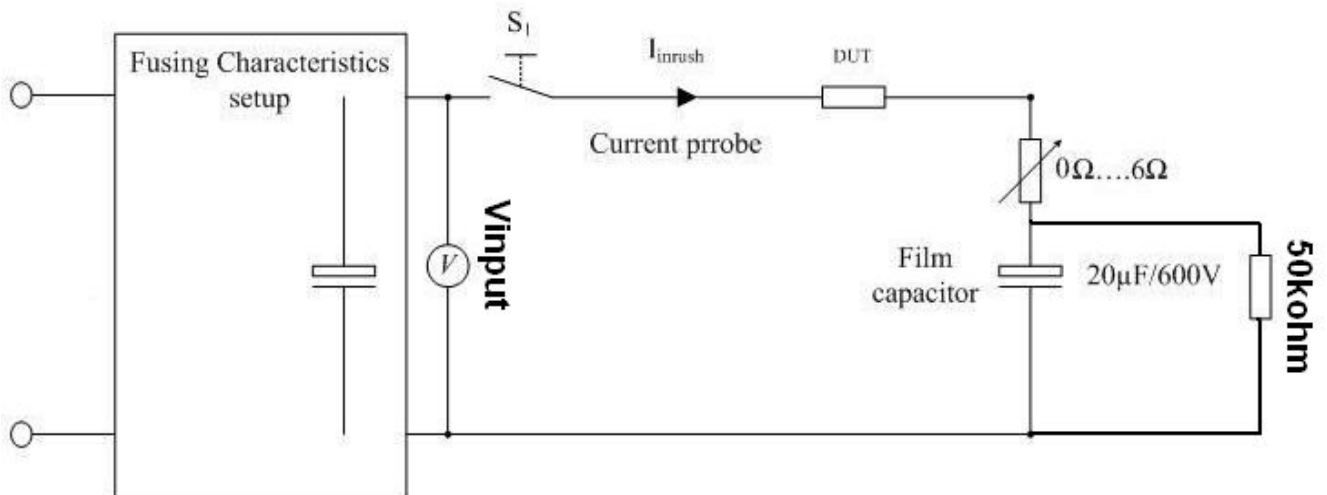

Measure the inrush current (I_{inrush}) directly after closing the switch S_1

WIRE WOUND RESISTORS, FLAMEPROOF/RESIN PAINT

8. Packing for P-15 Form:

8.1 Label on inner box:

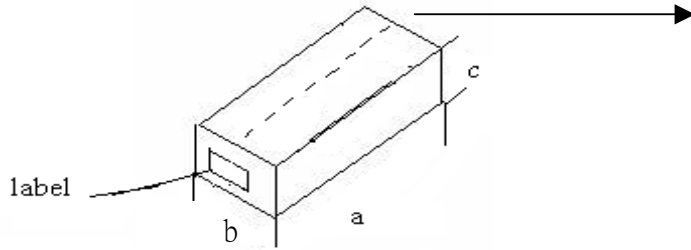

QTY PER BOX (pcs)	a(mm)	b(mm)	c(mm)
2500	251	203	90



8.2 Label on carton:

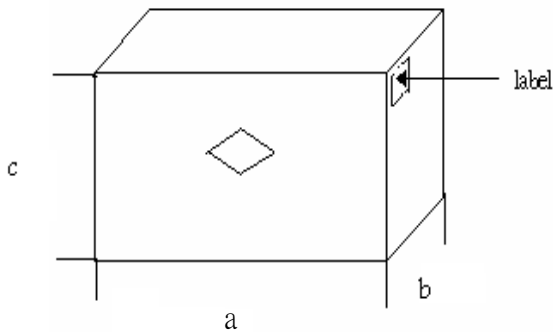

20 pcs per tray

QTY PER CARTON (pcs)	a(mm)	b(mm)	c(mm)
15000	425	275	295

X-ON Electronics

Largest Supplier of Electrical and Electronic Components

Click to view similar products for [Thick Film Resistors - Through Hole](#) category:

Click to view products by [Tyohm](#) manufacturer:

Other Similar products are found below :

[M8340104K3300GCD03](#) [M8340105K3300GGD03](#) [M8340105K3922FGD03](#) [M8340107K2401GCD03](#) [M8340109K1002JCD03](#)

[M8340109K1003GCD03](#) [MP850-3.00-1%](#) [ARC3.11 2M J A](#) [M8340105K1003GCD03](#) [M8340105M2201GCD03](#) [M8340107M7501GCD03](#)

[M8340108K2051FCD03](#) [M8340108K7501GCD03](#) [M8340108M5100JGD03](#) [M8340109K1000GCD03](#) [MOX-GRD-001](#)

[M8340102M4701GBD04](#) [M8340102K1002GBD04](#) [M8340109K2002GGD03](#) [M8340108K2002FGD03](#) [OE1305](#) [MS-221-82R5](#) [MOX-](#)

[750231004DE](#) [MOX-4-127505J](#) [SM102034504FE](#) [MOX300002206FE](#) [MOX-400233004F](#) [MOX300001005BE](#) [SM104066008J](#) [MOX-](#)

[400262008PE](#) [MOX-400232506FE](#) [MOX-400234007FE](#) [MOX-400221006G](#) [MOX-750235006ME](#) [SM103032506FE](#) [SM202022005FE](#)

[MOX1125231002FE](#) [MOX-1-122504F](#) [MOX-400225003F](#) [MOX1125731008FE](#) [MOX-5-126002JE](#) [MS176-2.20M-1%](#) [MOX-830212453BE](#)

[TRHE01A270RJ2E](#) [TRHE01A560RJ2E](#) [TRHP01A200RF2E](#) [TRHP01A5001F2E](#) [MG715-2.40M-1%](#) [MS214-20.0K-1%](#) [MF0W4FF4702A50](#)