



Document No.:S-E03

TY-OHM ELECTRONIC WORKS CO.,LTD.

**CARBON FILM RESISTORS, FLAMEPROOF
RESISTOR SPECIFICATION**

Version : 2017.A

APPROVED BY

APPROVED	REVIEWED	PREPARED
<i>Jacob Lee</i> Feb 10, 2017	<i>Daron Chen</i> Feb 10, 2017	<i>Rob Lo</i> Feb 10, 2017

CARBON FILM RESISTORS, FLAMEPROOF

1. Applicable Scope:

This standard specification is for use in consumer electronics, computers, telecommunications, control instruments...etc.

2. Part Number:

It is composed by Type, Rated Wattage, Nominal Resistance, Tolerance and Package/Terminal Form. e.g.

RD 1/4W 10R J T/B
Type Rated Wattage Nominal Resistance Tolerance Package/Terminal Form

2.1 Type :

Carbon Film Resistors are called "RD". "RDN" represents flameproof.

2.2 Rated Wattage:

Shown by "W", such as RD 1/8W(1/6W,1/4WS),1/4W(1/2WS),1/2W; RDN 1W,2W.

2.3 Nominal Resistance:

Ω , $K\Omega$, $M\Omega$ are its unit, which be in accordance with JIS-C6409 article 6 (EIA RS-196A) series.

Letter "10R" indicates resistance value 10Ω .

2.4 Tolerance:

It is measured by Bridge-method at room temperature and expressed by a capital letter.

G = $\pm 2\%$, J = $\pm 5\%$, K = $\pm 10\%$.

2.5 Package/Terminal Form:

T/R = tape & reel ; T/B = tape in box; Nil = Bulk ; MG form, M form, F form.

Remark : RD Series Resistors are RoHS & Halogen Free Compliant.

3. Rated Power:

Rated power is the value of Max load wattage specified at the ambient temperature of 70°C , and shall meet the functions of electrical and mechanical performance. When the ambient temperature surpasses above mentioned temperature, the value declines as per following DERATING CURVE

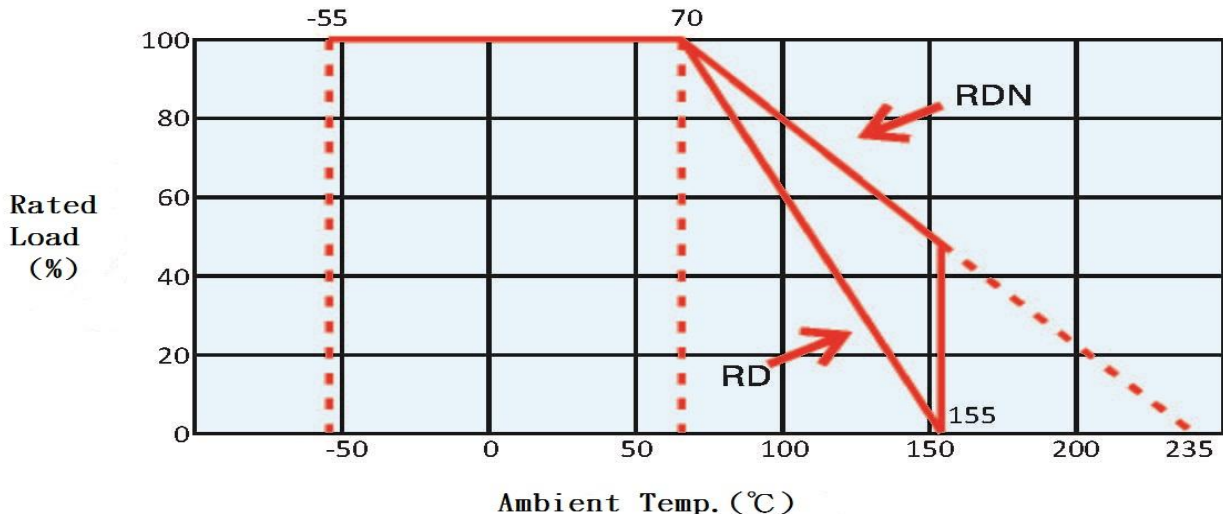

CARBON FILM RESISTORS, FLAMEPROOF

3.1 Rated Voltage:

It is calculated through the following formula:

where E: rated voltage (V)

P: rated power (W)

R: nominal resistance value (Ω)

$$E = \sqrt{PXR}$$

However, in case the voltage calculated exceeds the maximum load voltage, such the maximum load voltage shall be regarded as its rated voltage, means whichever less.

4. Dimension and structure:

4.1 Dimension:

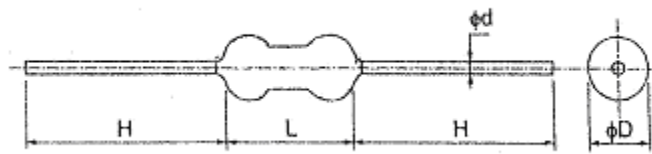

Unit: mm

TYPE	D \pm 1	L \pm 1	H \pm 3	d \pm 0.1	Resistance Range	Max Working Voltage
RD 1/8W, 1/6W(1/4WS)	1.7 \pm 0.2	3.7max	28	0.45	3.9 Ω ~4.7M Ω	200V
RD 1/4W(1/2WS)	2.4 \pm 0.5	6.4	28	0.6	3.9 Ω ~10M Ω	250V
RD 1/2W	3.5	9	28	0.65	3.9 Ω ~10M Ω	350V
RDN 1W	4.5	11	28	0.8	3.9 Ω ~10M Ω	500V
RDN 2W	5	15	28	0.8	3.9 Ω ~10M Ω	750V

- © Notes: 1. too low or too high ohm value can be supplied only case by case.
 2. Max Overload Voltage is 2 times of Max Working voltage.
 3. Resistance value over 4.7M Ω (\geq 4.7M Ω), while RD 1/8W is \geq 1M Ω , the tolerance shall be \pm 10%.
 4. RD 1/4W, 1/2W can also supply flameproof form (RDN).

4.2 STRUCTURE:

4.2.1 Ceramic Rod:

It is made of Forsterite imported.

4.2.2 Carbon Film:

Under high vacuum and high temperature to split and oxidize the pure carbon-hydric.

4.2.3 Terminal:

Terminal is to be firmly connected with resistors element, both electrically and mechanically, and allow easy soldering.

4.2.4 Coating:

Coating is done by EPOXY insulating paint which is solid enough to be free from looseness, crack and easy breakage. The paint shall be limited within 1mm of lead wires from resistors body while the rated wattage is 2W the paint is limited within 2mm. RDN type is coated by flameproof paint which is resistant to 800 $^{\circ}$ C without causing looseness, crack and easy breakage.

4.2.5 Marking:

Marking is made by color coding on surface.

CARBON FILM RESISTORS, FLAMEPROOF

5. Operating Temperature Range: -55°C ~ 155°C

6. Mechanical Performance:

6.1 Terminal tensile:

To Fix the resistor body, a static load of 1.5kgs. (1/8W & 1/4W axial form:1kg.) is to be gradually applied into the terminal for 10 seconds without causing any looseness and fall.

6.2 Twist withstand:

To bend the lead wire at the point of about 6mm from resistor body to 90°, then catch the wire at 1.2 ±0.4mm apart from the bent point end and turn it (clockwise) by 360 degrees perpendicular to the resistor axis at speed of 5 seconds per turn, and do the same counterclockwise again which constitute a whole turn. Repeat the turn 2 times without causing any break and looseness.

7. Electrical Performance:

7.1 Resistance Temperature Coefficient:

It shall be as following:

TYPE \ T.C.	0 ~ -450	0 ~ -700	0 ~ -1000	0 ~ -1300
1/6W , 1/8W	≤ 47KΩ	51KΩ ~100KΩ	110KΩ ~330KΩ	360KΩ ~1MΩ
1/4W & OVER	≤ 100KΩ	110KΩ ~1MΩ	1.1MΩ ~2.2MΩ	2.4MΩ ~4.7MΩ

$$T.C. (ppm/°C) = [(R2 - R1) \div R1] \times [1 \div (T2 - T1)] \times 10^6$$

where

R1: resistance value at reference temperature

R2: resistance value at test temp.

T1: reference temp. (usu. 25°C)

T2: test temp. (about 75°C)

7.2 Temperature Cycle:

Following temp. cycles are to be made 5 times and then put at room temp. for one hour, the resistance value change rate between pre-and-post test shall be within ±1%.

Steps	Temperature(°C)	Time (minutes)
1 st step	-55 ± 3	30
2 nd step	Room temp.	3
3 rd step	155 ± 3	30
4 th step	Room temp.	3

7.3 Short Time Over Load:

When the resistors are applied 2.5 times as much as rated voltage for 5 seconds continuously, it shows no evidence of arc, flame...etc. Removing the voltage and place the resistors to the normal condition for 30 minutes, the resistance value change rate between pre-and-post test shall be within ±1%.

7.4 Insulation Character :

Resistors are located in a V-shaped metal trough. Using the DC 100V or 500V megger instrument 2 poles to clutch either side of lead wires and metal trough, measuring the Insulation Resistance which shall be over 10000MΩ .

CARBON FILM RESISTORS, FLAMEPROOF

7.5 Voltage Withstanding:

Resistors are located in a V-shaped metal trough. RD: applying Max overload voltage for one minute (RDN: applying 350V AC for one minute) and should find no physical damage to the resistors. The resistance value change shall be within $\pm 0.5\%$.

7.6 Load Life:

The resistors arrayed are sent into the 70°C oven, applying rated voltage at the cycle of 1.5 hours ON, 0.5 hour OFF for 1000_{-0}^{+48} hours in total. Then, after removing the voltage, take the resistors out of the oven and left under normal temp. for one hour cooling. The resistance value change rate between pre-and-post test shall be within $\pm 5\%$.

7.7 Moisture-proof Load Life:

The resistors arrayed are placed into a constant temp./humidity oven at the temp. of $40 \pm 2^{\circ}\text{C}$ and the humidity of 90~95%, then rated power is applied for 1.5 hours and cut off for 0.5 hour. The similar cycle will be repeated for 500_{-0}^{+24} hours in total (including cut-off time). Then remove the voltage, taking the resistors out of the oven and leaving them at room temp. for one hour. The resistance value change rate between pre-and-post test shall be within $\pm 5\%$. There also shall be no evidence of remarkable change on appearance, and the marking shall not be illegible.

7.8 Solder-ability:

The leads with flux are dipped in a melted solder of $235 \pm 5^{\circ}\text{C}$ for 2 seconds, more than 95% of the circumference of the lead wires shall be covered with solder.

7.9 Resistance to Soldering Heat:

Two leads are together dipped in a melted solder of $270 \pm 5^{\circ}\text{C}$ for 10 ± 1 seconds, or $350 \pm 10^{\circ}\text{C}$ for 3.5 ± 0.5 seconds, Then remove the resistors and leaving them at room temp. for one hour. The resistance value change rate between pre-and-post test shall be within $\pm 1\%$.

7.10 Nonflammability:(only for RDN)

The resistors are applied the power of 16 times the rated wattage for 5 min. and shall not get flame.

8. Forming:

8.1 MG Form:

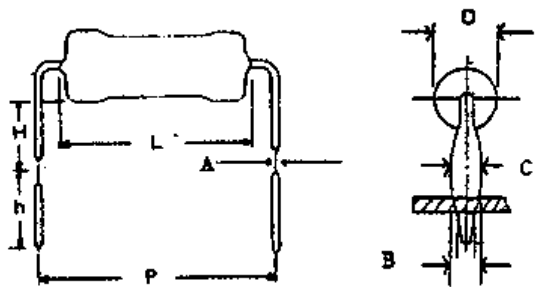

Unit: mm

Wattage	L ± 1	D ± 1	P	H	h ± 1	A ± 0.02	B ± 0.05	C ± 0.2
1/4W(1/2WS)	6.4	2.4 ± 0.5	10 ± 1	7 ± 1	4.5	0.2	0.8	1.2
1/2W	9	3.5	15 ± 1.5	7 ± 1	4.5	0.2	0.8	1.2
1W	11	4.5	15 ± 1.5	7 ± 1	4.5	0.3	1	1.4
2W	15	5	20 ± 2	10 ± 2	4.5	0.3	1	1.4

CARBON FILM RESISTORS, FLAMEPROOF

8.2 M Form:

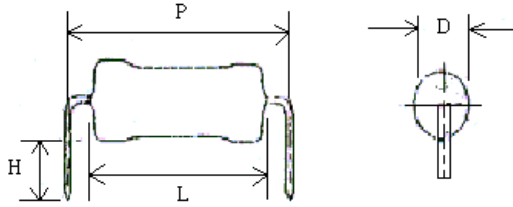

Unit: mm

Wattage	$L \pm 1$	$D \pm 1$	P	$H \pm 0.5$
1/8W、1/6W、1/4WS	3.7max	1.7 ± 0.2	5 ± 0.5	3.5
1/4W、1/2WS	6.4	2.4 ± 0.5	10 ± 1	3.5
1/2W	9	3.5	15 ± 1.5	3.5
1W	11	4.5	15 ± 1.5	3.5
2W	15	5	20 ± 2	3.5

8.3 F Form:

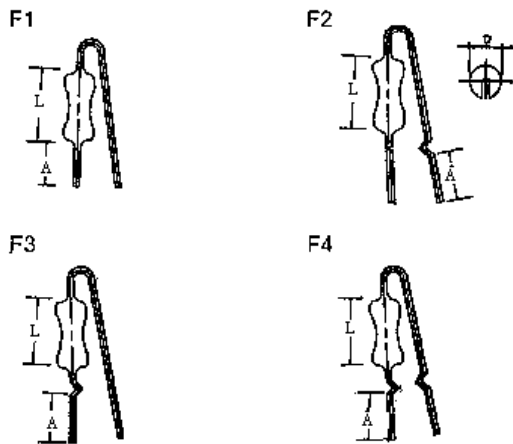

Unit: mm

Wattage	$L \pm 1$	$D \pm 1$	$A + 1 / -0.5$	Applicable
1W	11	4.5	3.5	F1~F4
2W	15	5	3.5	F1~F4

9. Packing:

9.1 Taping Specifications:

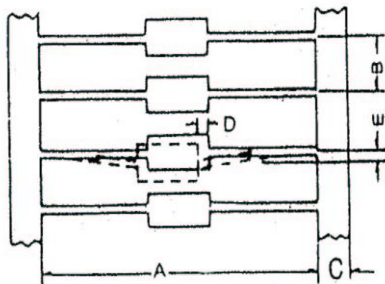

Unit: mm

Wattage	Size		A	B	$C \pm 1$	D Max	E Max
	Type						
$\leq 1/4W$	T-26	$26 + 1 / -0$	5 ± 0.5	6	0.6	1.2	
	T-52	52 ± 1	5 ± 0.5	6	0.6	1.2	
1/2W	T-52	52 ± 1	5 ± 0.5	6	0.6	1.2	
1W	T-63	63 ± 1	5 ± 0.5	6	0.6	1.2	
2W	T-63	63 ± 1	10 ± 1	6	0.6	1.2	
	T-76	76 ± 1.5	10 ± 1	6	0.6	1.2	

CARBON FILM RESISTORS, FLAMEPROOF

9.2 Tape in Box:

Unit: mm

Wattage	TYPE	QTY PER BOX	a	b	c
1/8W, 1/6W, (1/4WS)	T-26	5,000	50	70	255
	T-52	5,000	75	70	255
1/4W (1/2WS)	T-26	4,000	50	90	255
	T-52	5,000	75	100	255
1/2W	T-52	1,000	75	55	255
1W	T-63	1,000	85	105	260
2W	T-63	1,000	100	110	265

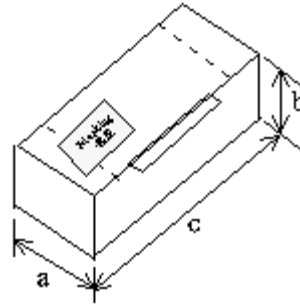

9.3 Tape & Reel:

Unit: mm

Wattage	TYPE	QTY PER REEL	A	B	C	D	E	F
1/4W (1/2WS)	T-52	5,000	285	310	75	80	295	295
1/2W	T-52	2,500	285	310	75	80	295	295
1W	T-63	2,000	285	310	75	95	295	295
2W	T-63	1,000	285	310	75	95	295	295
	T-76	1,000	285	310	90	105	295	295

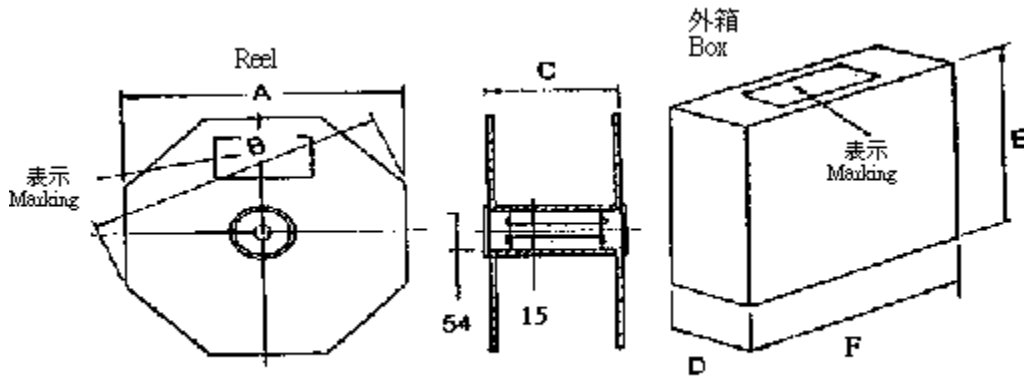

10. Precautions In Use:

To prevent electric corrosion risk (10 ppm defect rate over 1 year use), the resistance value over 100K Ω should be limited at 50V when ambient temperature and humidity is higher than 85 $^{\circ}$ C/85%.

X-ON Electronics

Largest Supplier of Electrical and Electronic Components

Click to view similar products for [Thick Film Resistors - Through Hole](#) category:

Click to view products by [Tyohm](#) manufacturer:

Other Similar products are found below :

[M8340104K3300GCD03](#) [M8340105K3300GGD03](#) [M8340105K3922FGD03](#) [M8340107K2401GCD03](#) [M8340109K1002JCD03](#)

[M8340109K1003GCD03](#) [MP850-3.00-1%](#) [ARC3.11 2M J A](#) [M8340105K1003GCD03](#) [M8340105M2201GCD03](#) [M8340107M7501GCD03](#)

[M8340108K2051FCD03](#) [M8340108K7501GCD03](#) [M8340108M5100JGD03](#) [M8340109K1000GCD03](#) [MOX-GRD-001](#)

[M8340102M4701GBD04](#) [M8340102K1002GBD04](#) [M8340109K2002GGD03](#) [M8340108K2002FGD03](#) [OE1305](#) [MS-221-82R5](#) [MOX-](#)

[750231004DE](#) [MOX-4-127505J](#) [SM102034504FE](#) [MOX300002206FE](#) [MOX-400233004F](#) [MOX300001005BE](#) [SM104066008J](#) [MOX-](#)

[400262008PE](#) [MOX-400232506FE](#) [MOX-400234007FE](#) [MOX-400221006G](#) [MOX-750235006ME](#) [SM103032506FE](#) [SM202022005FE](#)

[MOX1125231002FE](#) [MOX-1-122504F](#) [MOX-400225003F](#) [MOX1125731008FE](#) [MOX-5-126002JE](#) [MS176-2.20M-1%](#) [MOX-830212453BE](#)

[TRHE01A270RJ2E](#) [TRHE01A560RJ2E](#) [TRHP01A200RF2E](#) [TRHP01A5001F2E](#) [MG715-2.40M-1%](#) [MS214-20.0K-1%](#) [MF0W4FF4702A50](#)