



EVK-R10

LEXI-R10 series cellular evaluation kits

User guide



Abstract

This user guide explains how to set up the EVK-R10 evaluation kits to begin evaluating the u-blox ultra-small LEXI-R10 series modules supporting LTE Cat 1bis cellular radio access technology.

Document information

Title	EVK-R10	
Subtitle	LEXI-R10 series cellular evaluation kits	
Document type	User guide	
Document number	UBXDOC-686885345-1985	
Revision and date	R03	31-Jul-2024
Disclosure sensitivity	C1-Public	

This document applies to the following products:

Product name	Type number
EVK-R10401D	EVK-R10401D-00-00
EVK-R10801D	EVK-R10801D-00-00
EVK-LEXI-R10001D	EVK-LEXI-R10001D-01-00

u-blox or third parties may hold intellectual property rights in the products, names, logos, and designs included in this document. Copying, reproduction, or modification of this document or any part thereof is only permitted with the express written permission of u-blox. Disclosure to third parties is permitted for clearly public documents only.

The information contained herein is provided "as is" and u-blox assumes no liability for its use. No warranty, either express or implied, is given, including but not limited to, with respect to the accuracy, correctness, reliability, and fitness for a particular purpose of the information. This document may be revised by u-blox at any time without notice. For the most recent documents, visit www.u-blox.com.

Copyright © u-blox AG.

Contents

Document information	2
Contents	3
1 Introduction	4
2 Board quick start	6
2.1 Board setup	6
2.1.1 EVK-R10 new model.....	6
2.1.2 EVK-R10 old model.....	10
2.2 Switch off the cellular system.....	13
3 Register to network	14
3.1 Enabling error result codes	14
3.2 PIN code insertion (when required).....	14
3.3 Registration on a cellular network.....	14
4 EVK-R10 hardware	15
4.1 EVK-R10 new model	15
4.1.1 Block diagram and basic description	15
4.1.2 Switches, jumpers, and buttons.....	16
4.1.3 LEDs	17
4.1.4 Connectors.....	18
4.1.5 Pin out	19
4.1.6 Current consumption measurement.....	21
4.2 EVK-R10 old model	22
4.2.1 Block diagram and basic description	22
4.2.2 Switches, jumpers, and buttons.....	23
4.2.3 LEDs	24
4.2.4 Connectors.....	25
4.2.5 Pin out	26
4.2.6 Current consumption measurement.....	28
Appendix	29
A Setting up AT terminal communication	29
B Glossary	31
Related documentation	32
Revision history	32
Contact	32

1 Introduction

The EVK-R10 kits are a powerful and easy-to-use tool that simplifies the evaluation of the ultra-small u-blox LEXI-R10 series multi-band LTE Cat 1bis cellular modules. In details:

- The EVK-R10401D kit is available to evaluate the LEXI-R10401D data-only LTE Cat 1bis module that is mainly designed for operations in the North America region.
- The EVK-R10801D kit is available to evaluate the LEXI-R10801D data-only LTE Cat 1bis module that is mainly designed for operations in the Europe, Middle East, Africa, and Asia-Pacific regions.
- The EVK-LEXI-R10001D kit is available to evaluate the LEXI-R10001D data-only LTE Cat 1bis module that is designed for global use.

 See the data sheet [2] and the system integration manual [3] for features supported by each LEXI-R10 series module.

All evaluation kits of the u-blox LEXI-R10 series modules are herein simply referred as “EVK-R10”.

As shown in [Figure 1](#) and in [Figure 2](#), the EVK-R10 evaluation kits are formed by three boards:

- The motherboard, named “EVB-WL3”, contains the power supply and other peripherals for the cellular module.
- The cellular adapter board, named “ADP-R10”, contains the LEXI-R10 cellular module and other connectors.
- The GNSS adapter board, named “ADP-GNSS”, contains the u-blox MAX-M10S GNSS module, the GNSS antenna connector and the USB connector for the GNSS module.

Two hardware versions of the cellular adapter board (ADP-R10) containing the LEXI-R10 modules have been used for the EVK-R10 evaluation kits:

- The latest “new” version of the cellular adapter board, marked “AD_R10_CS_449000”, illustrated in [Figure 1](#), and described in sections [2.1.1](#) and [4.1](#). Any of the EVK-R10 evaluation kits including this “new” version of cellular adapter board are herein simply referred as “EVK-R10 new model”.
- The previous “old” version of the cellular adapter board, marked “VA_L43_CS_435000”, illustrated in [Figure 2](#), and described in sections [2.1.2](#) and [4.2](#). Any of the EVK-R10 evaluation kits including this “old” version of cellular adapter board are herein simply referred as “EVK-R10 old model”.

 Please check the cellular adapter board version that you have, and refer to the related proper sections “EVK-R10 new model” or “EVK-R10 old model” of this user guide accordingly.

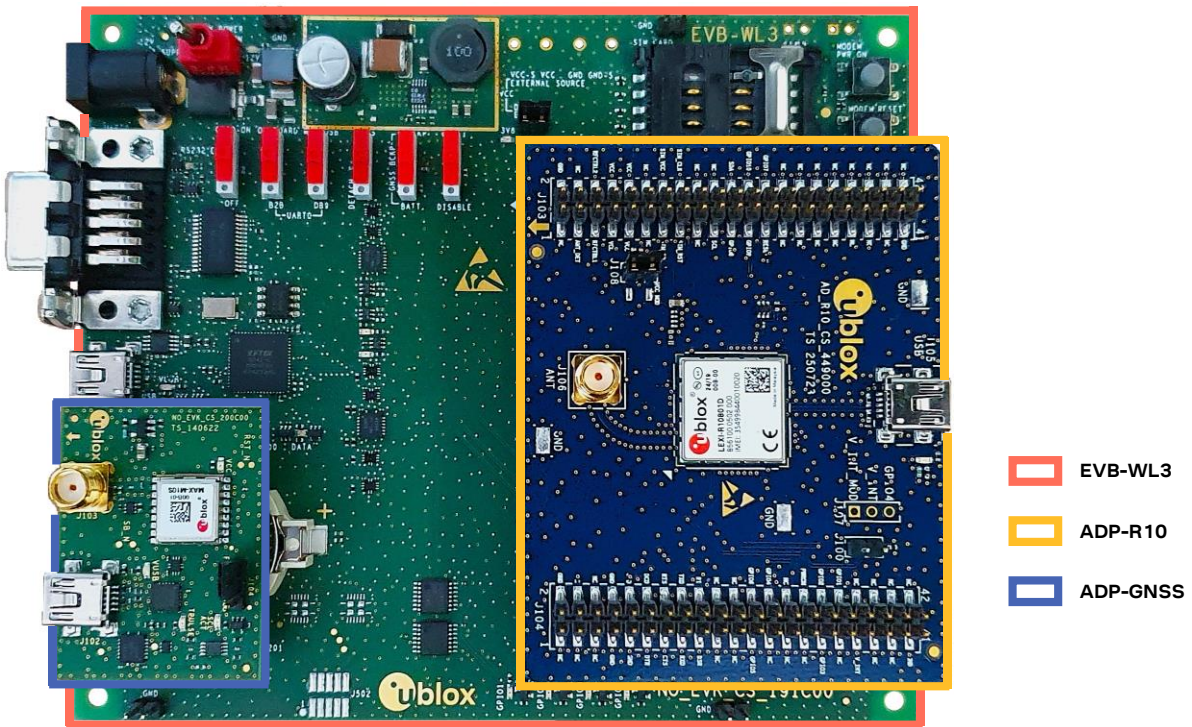

Figure 1: EVK-R10 evaluation kit “new” model, formed by three boards, with latest “new” version of the ADP-R10 board

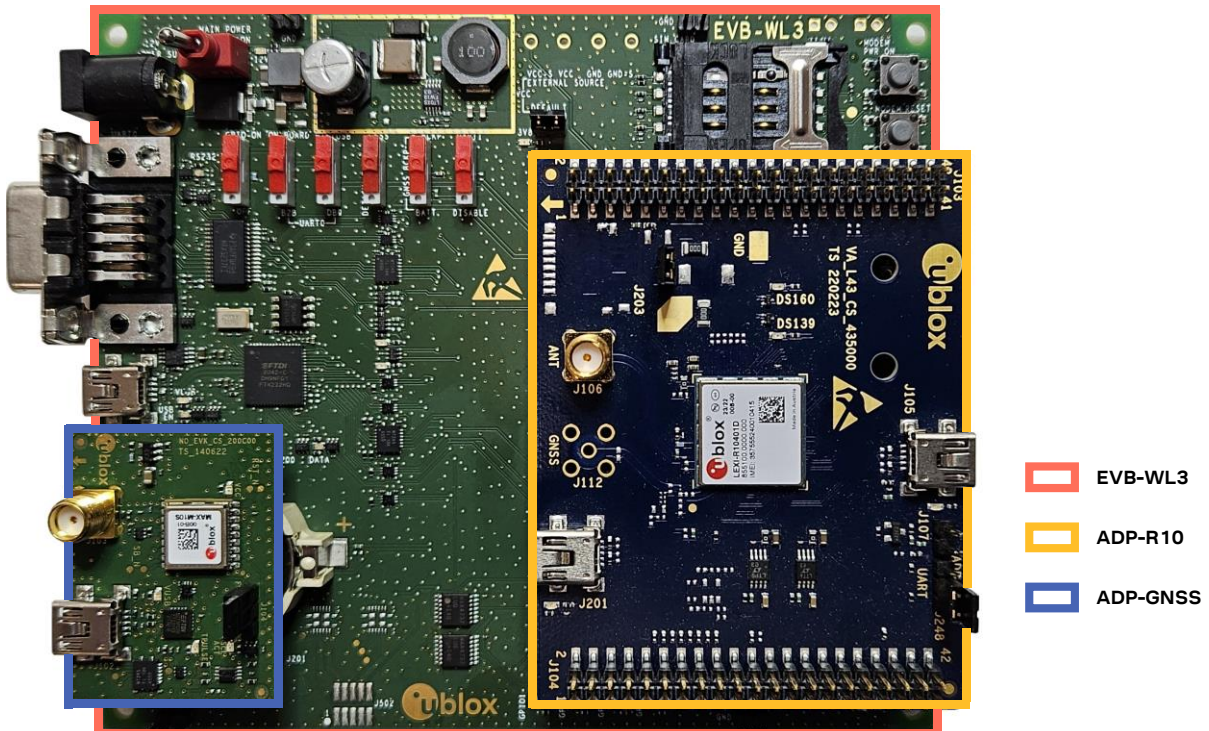

Figure 2: EVK-R10 evaluation kit “old” model, formed by three boards, with previous “old” version of the ADP-R10 board



For more hardware details about the EVK-R10 evaluation kit, see section 4.



The cellular adapter boards of the EVK-R10 evaluation kits can be purchased separately.

2 Board quick start

2.1 Board setup

2.1.1 EVK-R10 new model

2.1.1.1 SIM and antenna

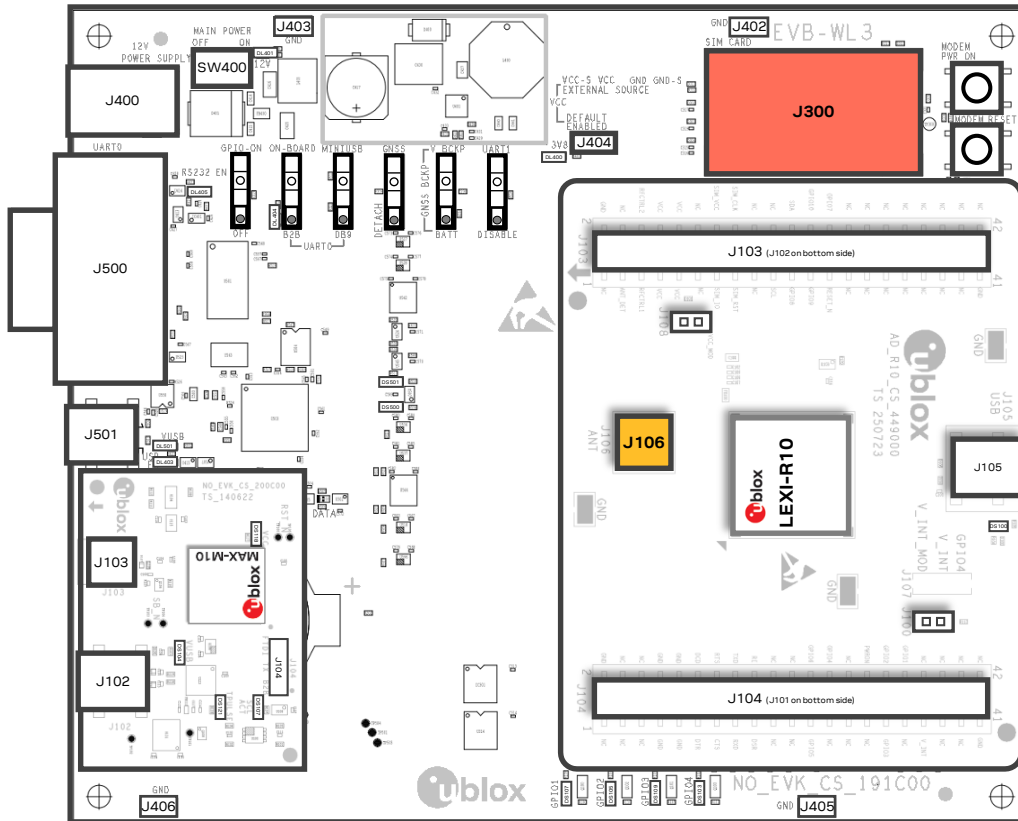

Figure 3: SIM and antenna set-up on EVK-R10 new model

1. Insert a SIM card into **J300**, the SIM card holder.
2. Connect the cellular antenna provided with the evaluation kit box to **J106**, the cellular antenna SMA connector.

2.1.1.3 Local connectivity

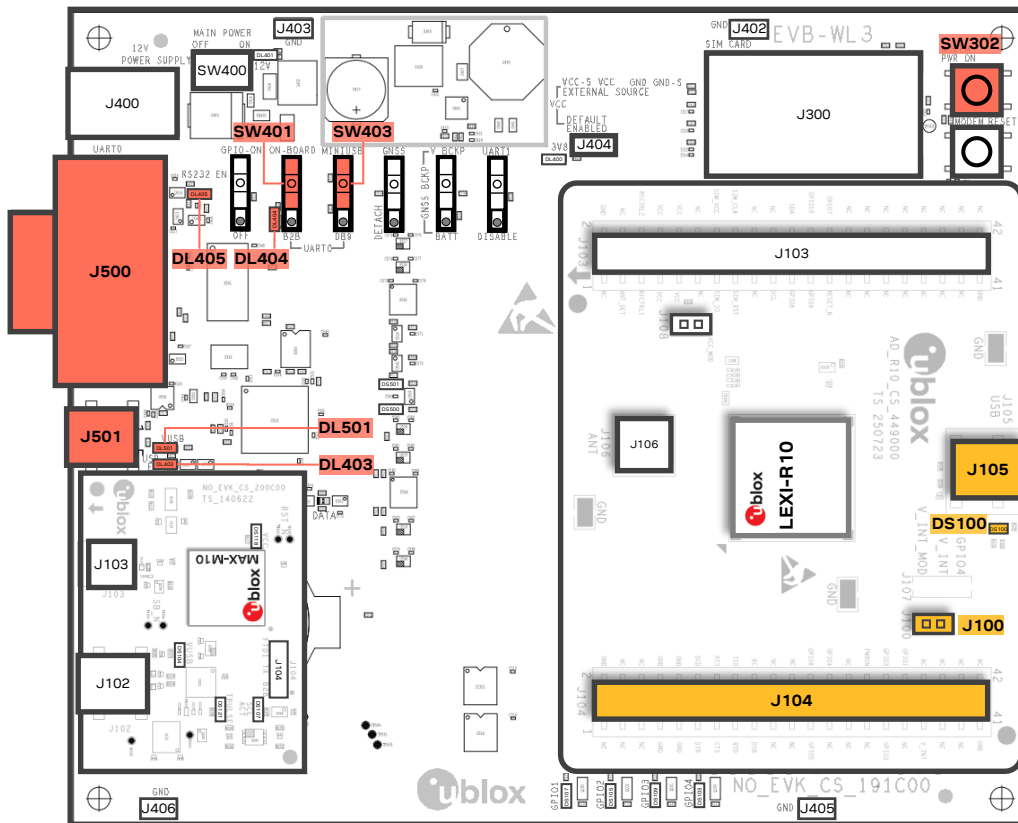

Figure 5: Local connectivity set up on EVK-R10 new model

2.1.1.3.1 Communication via USB

1. For communication via the cellular USB interface, connect a USB cable to **J105**, the Cellular native **USB** connector. LED **DS100** turns blue.
2. Press **SW302**, the cellular power-on button, to switch on the cellular system of LEXI-R10 module.
3. Once the cellular system switched on, the COM ports in the [Table 1](#) are enabled by the Windows USB driver after the module boot (see Windows device manager for numbering of ports)¹:

Parameter	Type	Remarks
u-blox Modem	Ports (COM & LPT)	Diagnostic log
u-blox Modem	Ports (COM & LPT)	AT command interface and data communication
u-blox Modem	Ports (COM & LPT)	AT command interface and data communication

Table 1: Cellular USB interface configuration

Run an AT terminal (e.g., the u-blox m-center tool), select the AT port with below settings:

Data rate	Data bits	Parity	Stop bits	Flow control
115200 bit/s	8	N	1	HW

See appendix [A](#) for how to configure the u-blox m-center AT terminal for Windows.

To execute the FW update of the LEXI-R10 module over USB, a jumper socket must be inserted on the 2-pin header connector **J100** on the cellular adapter board. Otherwise, for normal boot and operation of the module, do not insert any jumper socket on the 2-pin header connector **J100**.

¹ A message “driver installation fail” may appear on Windows if the USB cable has been connected before the end of the module boot, but this can be ignored as the normal operating functionality will be available anyway after the end of the module boot.

2.1.1.3.2 Communication via UART

For communication via the UART interfaces of the cellular module, the following connections are allowed and can be alternatively enabled in a mutually exclusive way (see [Table 2](#) for switches and jumper position and LED status):

- a. Connect a USB cable to **J501** (mini-USB), the cellular USB main UART; the LED **DL501** light turns blue. When a USB cable is connected to this mini-USB connector, two COM ports are enabled in Windows: the main 8-wire UART interface of the LEXI-R10 module is available over the first COM port opened by the driver, after the end of the boot of the LEXI-R10 module. Press **SW302**, the cellular power-on button, to switch on the LEXI-R10 module.
- b. Connect an RS232 cable to **J500**, the cellular RS232 main UART, a DB9 connector: the main 8-wire UART interface of the LEXI-R10 module is available over RS232, after the end of the boot of the module. Press **SW302**, the power-on button, to switch on the LEXI-R10 module.

Type of connections	SW401	SW403	LED
Access to the main UART interface over J501 (EVB-WL3)	ON BOARD	MINIUSB	DL403 DL501
Access to the main UART interface over J500 (EVB-WL3)	ON BOARD	DB9	DL405
Access to UART interface(s) over J104 (ADP-R10)	B2B	Not relevant	DL404

Table 2: Serial interface configuration

 See the data sheet [\[2\]](#) and the +USIO AT command description in the AT commands manual [\[1\]](#) for the description and configuration of the USIO variants.

Run an AT terminal (such as the u-blox m-center tool) selecting the AT port, with these settings:

Data rate	Data bits	Parity	Stop bits	Flow control
115200 bit/s	8	N	1	HW

See appendix [A](#) for how to configure the u-blox m-center AT terminal for Windows.

2.1.2 EVK-R10 old model

2.1.2.1 SIM and antenna

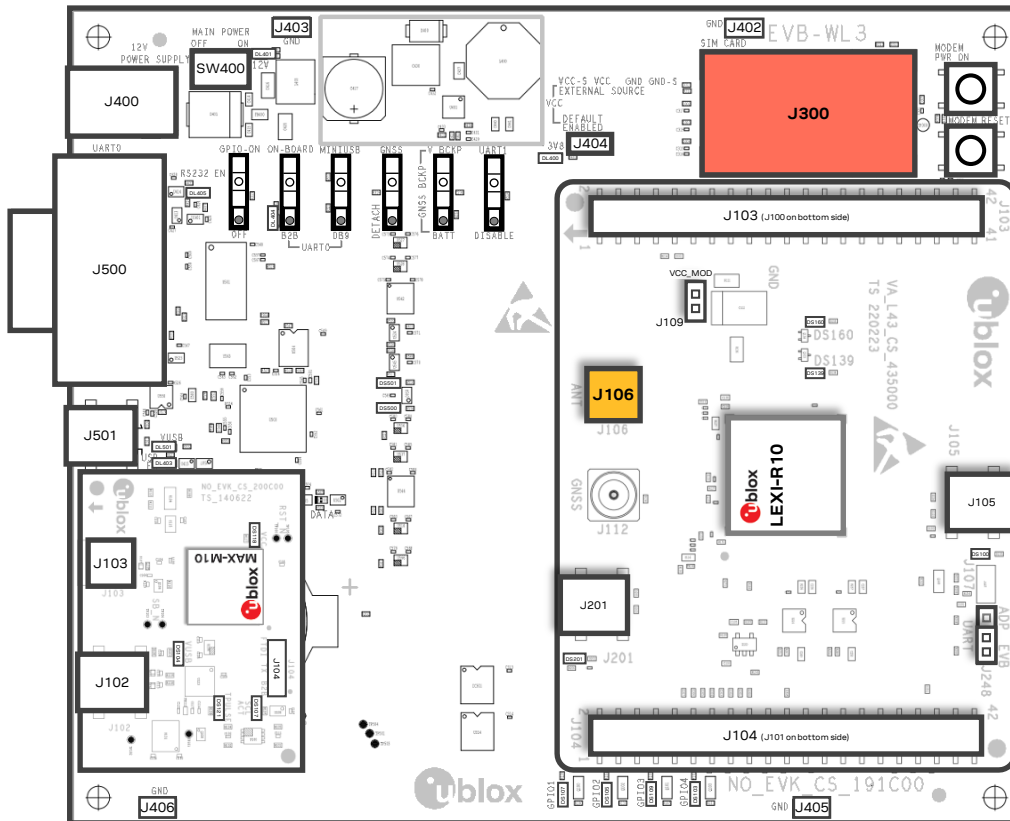

Figure 6: SIM and antenna set-up on EVK-R10 old model

1. Insert a SIM card into **J300**, the SIM card holder.
2. Connect the cellular antenna provided with the evaluation kit box to **J106**, the cellular antenna SMA connector.

2.1.2.2 Power supply

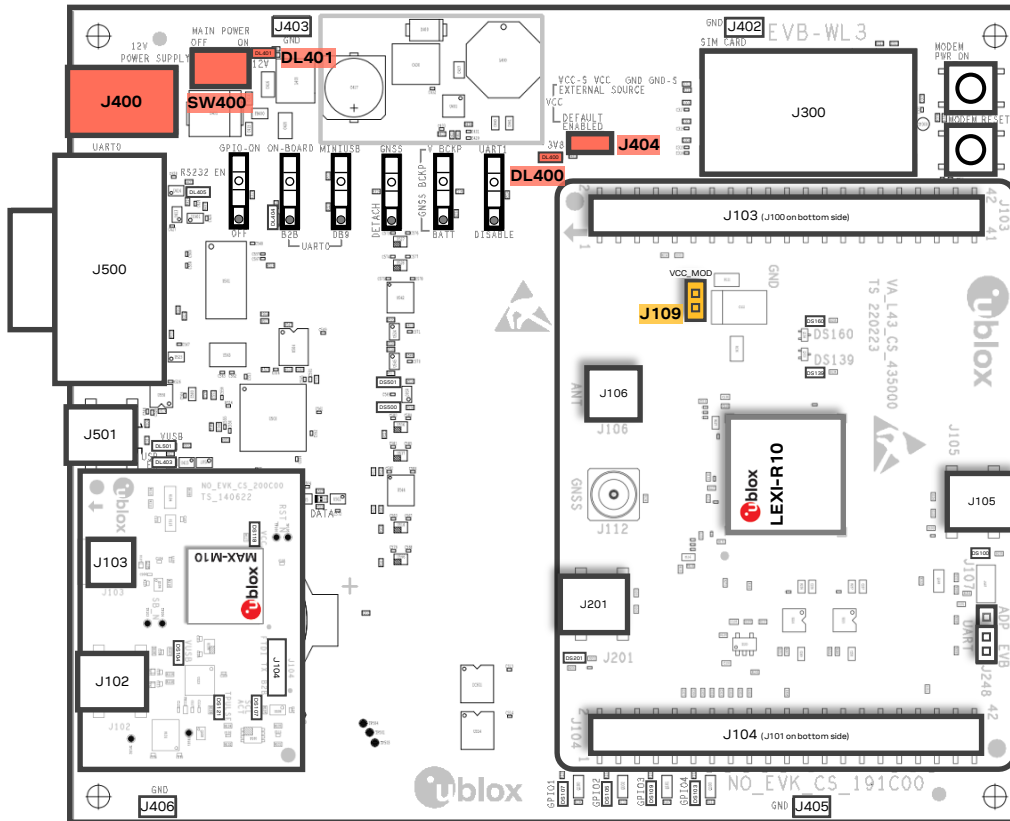

Figure 7: Power supply set up on EVK-R10 old model

1. Connect the AC/DC +12 V power supply adapter to **J400**, the 9 – 18 V power input connector; LED **DL401** light turns blue;
2. Provide a jumper socket on both **J404** and **J109**, the cellular VCC supply jumpers;
3. Turn **SW400**, the main power switch, to the “ON” position; LED **DL400** light turns green.

2.1.2.3 Local connectivity

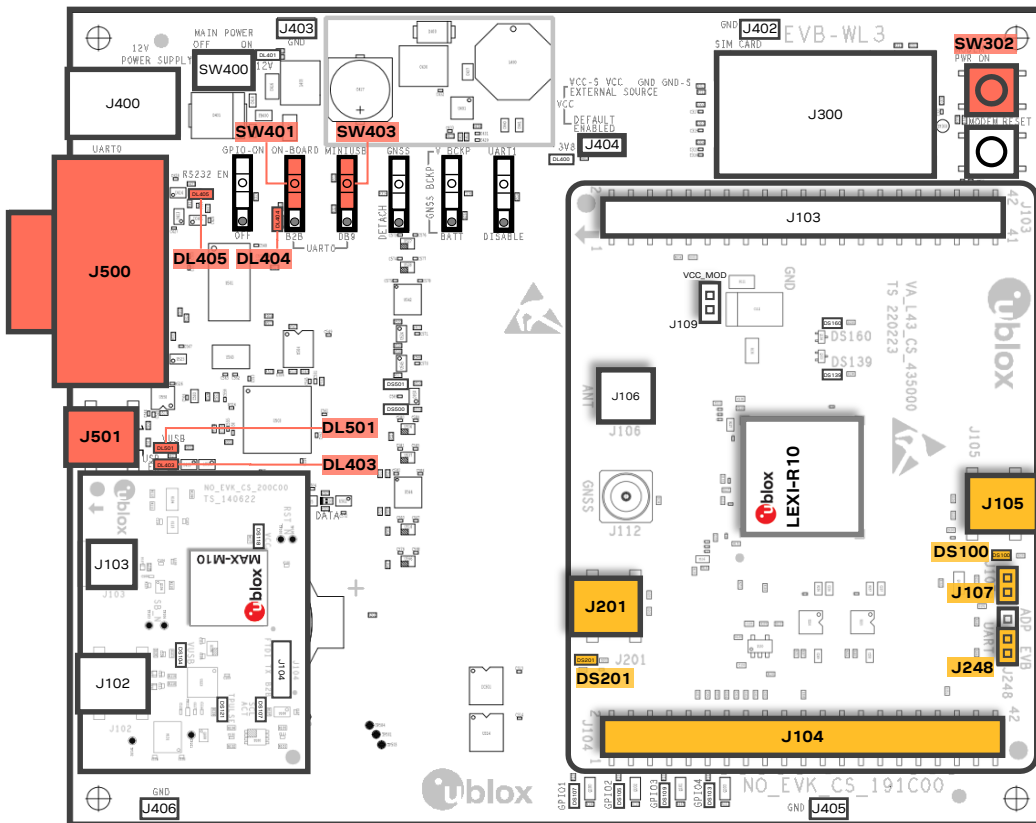

Figure 8: Local connectivity set up on EVK-R10 old model

2.1.2.3.1 Communication via USB

1. For communication via the cellular USB interface, connect a USB cable to **J105**, the Cellular native **USB** connector. LED **DS100** turns blue.
2. Press **SW302**, the cellular power-on button, to switch on the cellular system of LEXI-R10 module.
3. Once the cellular system switched on, the COM ports in the [Table 3](#) are enabled by the Windows USB driver after the module boot (see Windows device manager for numbering of ports)²:

Parameter	Type	Remarks
u-blox Modem	Ports (COM & LPT)	Diagnostic log
u-blox Modem	Ports (COM & LPT)	AT command interface and data communication
u-blox Modem	Ports (COM & LPT)	AT command interface and data communication

Table 3: Cellular USB interface configuration

Run an AT terminal (e.g., the u-blox m-center tool), select the AT port with below settings:

Data rate	Data bits	Parity	Stop bits	Flow control
115200 bit/s	8	N	1	HW

See appendix [A](#) for how to configure the u-blox m-center AT terminal for Windows.

To execute the FW update of the LEXI-R10 module over USB, a jumper socket must be inserted on the 2-pin header connector **J107** on the cellular adapter board. Otherwise, for normal boot and operation of the module, do not insert any jumper socket on the 2-pin header connector **J107**.

² A message “driver installation fail” may appear on Windows if the USB cable has been connected before the end of the module boot, but this can be ignored as the normal operating functionality will be available anyway after the end of the module boot.

2.1.2.3.2 Communication via UART

For communication via the UART interfaces of the cellular module, the following connections are allowed and can be alternatively enabled in a mutually exclusive way (see [Table 4](#) for switches and jumper position and LED status):

- a. Connect a USB cable to **J501** (mini-USB), the cellular USB main UART; the LED **DL501** light turns blue. When a USB cable is connected to this mini-USB connector, two COM ports are enabled in Windows: the main 8-wire UART interface of the LEXI-R10 module is available over the first COM port opened by the driver, after the end of the boot of the LEXI-R10 module. Press **SW302**, the cellular power-on button, to switch on the LEXI-R10 module.
- b. Connect an RS232 cable to **J500**, the cellular RS232 main UART, a DB9 connector: the main 8-wire UART interface of the LEXI-R10 module is available over RS232, after the end of the boot of the module. Press **SW302**, the power-on button, to switch on the LEXI-R10 module.
- c. Connect a USB cable to **J201** (mini-USB), the cellular USB two UARTs; the LED **DS201** light turns blue. When a USB cable is connected to this mini-USB connector, two COM ports are enabled in Windows: the two 4-wire UART interfaces of the LEXI-R10 module are respectively available over the two numbered COM ports opened by the driver, after the end of the boot of the module. Press **SW302**, the cellular power-on button, to switch on the LEXI-R10 module. To enable two UART interfaces, see the AT commands manual [\[1\]](#), +USIO AT command.

Type of connections	SW401	SW403	J248	LED
Access to the main UART interface over J501 (EVB-WL3)	ON BOARD	MINIUSB	Jumper socket on pins 1-2	DL403 DL501
Access to the main UART interface over J500 (EVB-WL3)	ON BOARD	DB9	Jumper socket on pins 1-2	DL405
Access to the two UART interfaces over J201 (ADP-R10)	B2B	Not relevant	Jumper socket on pins 2-3	DL404 DS201
Access to UART interface(s) over J104 (ADP-R10)	B2B	Not relevant	No jumper socket	DL404

Table 4: Serial interface configuration

See the data sheet [\[2\]](#) and the +USIO AT command description in the AT commands manual [\[1\]](#) for the description and configuration of the USIO variants.

Run an AT terminal (such as the u-blox m-center tool) selecting the AT port, with these settings:

Data rate	Data bits	Parity	Stop bits	Flow control
115200 bit/s	8	N	1	HW

See appendix [A](#) for how to configure the u-blox m-center AT terminal for Windows.

2.2 Switch off the cellular system

To switch off the cellular system in the EVK-R10, send the +CPWROFF AT command.

Issue AT+CPWROFF command before switching off the main power supply, otherwise settings and configuration parameters may not be saved in the non-volatile memory of the cellular module.

3 Register to network

3.1 Enabling error result codes

Command sent by DTE (user)	DCE response (module)	Description
AT+CMEE=2	OK	Enable the cellular module to report verbose error result codes.

3.2 PIN code insertion (when required)

Command sent by DTE (user)	DCE response (module)	Description
AT+CPIN="8180"	OK	Enter the PIN code, if needed (enter the PIN of the SIM card – 8180 is an example).
AT+CLCK="SC",0,"8180"	OK	Unlock the PIN at power-on (the last parameter is the PIN of the SIM card – 8180 is an example).
AT+CLCK="SC",1,"8180"	OK	Lock the PIN at power-on (the last parameter is the PIN of the SIM card – 8180 is an example).

3.3 Registration on a cellular network

Command sent by DTE (user)	DCE response (module)	Description
AT+CREG?	+CREG: 0,1 OK	Verify the CS network registration.
AT+CEREG?	+CEREG: 0,1,"5684","03761b14",7 OK	Verify the EPS network registration.
AT+COPS=0	OK	Register the module on the network. The cellular module automatically registers itself on the cellular network. This command is necessary only if the auto-registration failed (AT+CREG? returns 0,0).
AT+COPS?	+COPS: 0,0,"I TIM",7 OK	Read the operator name and radio access technology (RAT).

For the complete description and syntax of the AT commands supported by LEXI-R10 series modules, see the AT commands manual [\[1\]](#).

4 EVK-R10 hardware

4.1 EVK-R10 new model

4.1.1 Block diagram and basic description

Figure 9 shows the main interfaces and internal connections of the EVK-R10 evaluation kit:

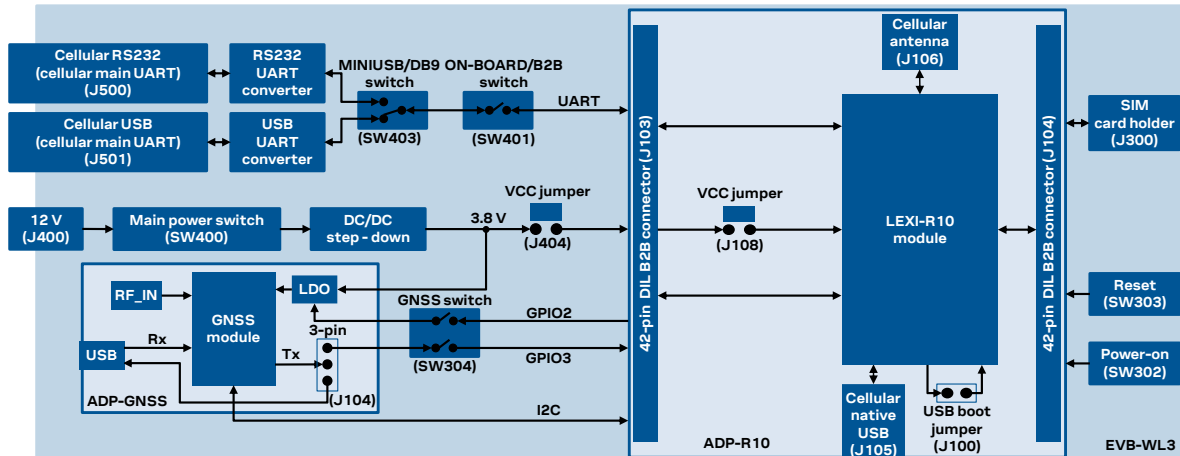

Figure 9: Block diagram of EVK-R10 new model

The ADP-R10 and the ADP-GNSS are connected by male header board-to-board connectors on the bottom of the adapter boards and their corresponding female connectors on top of the EVB-WL3.

As illustrated in section 2.1.1.3 and summarized in Table 2, for communication via the UART interfaces of the cellular module, two options are allowed and can be enabled in a mutually exclusive way.

The USB interface of the cellular module is available on the native USB connector (**J105**) mounted on the cellular adapter board. Other LEXI-R10 peripherals are available on the dual-in-line male board-to-board connectors (**J103** and **J104**) provided on the top layer of the cellular adapter board.

Other LEXI-R10 peripherals are available on the dual-in-line male board-to-board connectors (**J103** and **J104**) provided on the top layer of the cellular adapter board.

4.1.2 Switches, jumpers, and buttons

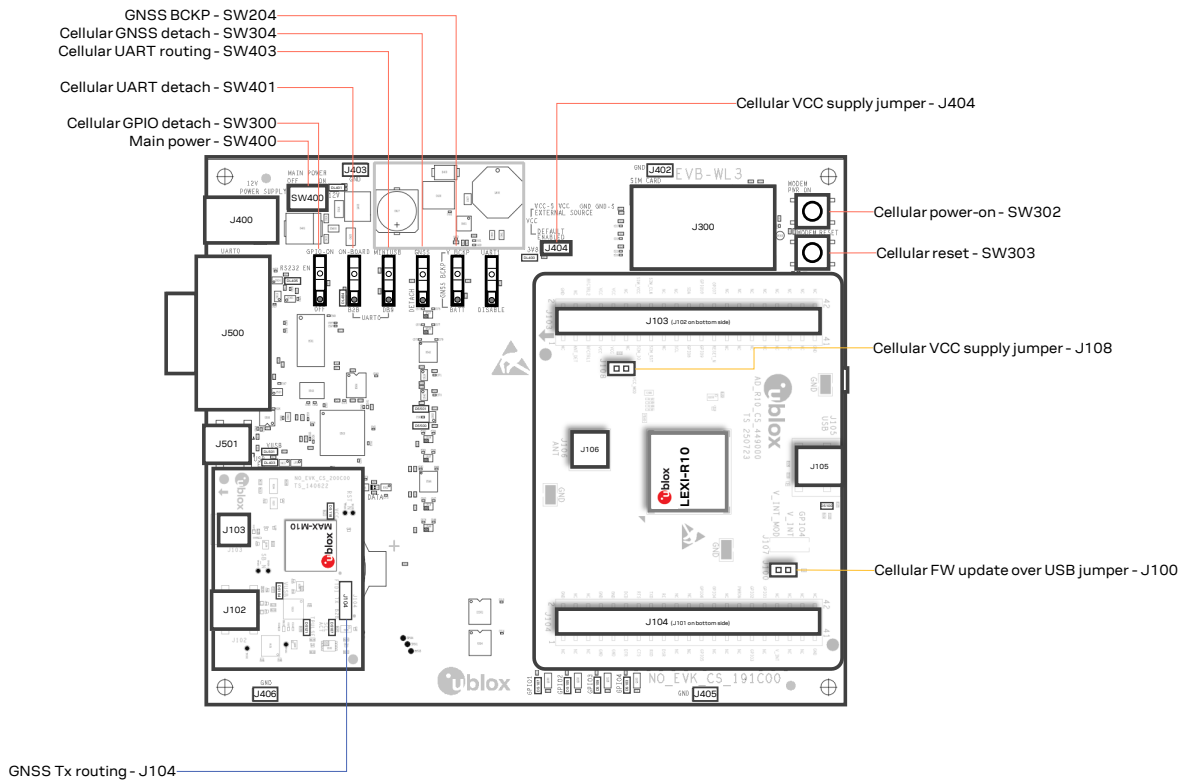

Function	Description	Name	Board
Main power switch	Power on / off the whole evaluation kit	SW400	EVB-WL3
Cellular VCC	Jumper socket to provide the 3.8 V supply to the cellular VCC input	J404	EVB-WL3
		J108	ADP-R10
Cellular power-on	Push button to switch on / off LEXI-R10 modules	SW302	EVB-WL3
Cellular reset	Push button to reset LEXI-R10 modules	SW303	EVB-WL3
Cellular UART detach	Slide switch to attach / detach cellular main UART from USB / RS232 connectors	SW401	EVB-WL3
Cellular UART routing	Slide switch to select cellular main UART routing on USB or RS232 connector	SW403	EVB-WL3
Cellular GPIO detach	Slide switch to attach / detach the cellular GPIOs from peripherals: when detached, the signals are available only on DIL B2B connector on ADP-R10	SW300	EVB-WL3
Cellular GNSS detach	Slide switch to attach / detach the cellular system to the GNSS module mounted on the ADP-GNSS: when detached, signals are available only on DIL B2B connector on ADP-R10 board	SW304	EVB-WL3
GNSS BCKP	Slide switch to connect / disconnect backup battery to V_BCKP pin of the GNSS module mounted on the ADP-GNSS	SW204	EVB-WL3
FW update over USB	Jumper socket to execute the FW update of the LEXI-R10 module over USB	J100	ADP-R10
GNSS Tx routing	3-pin header jumper to route and make accessible GNSS UART Tx over the USB connector on the ADP-GNSS or to use it as Tx data ready for the cellular module	J104	ADP-GNSS

Table 5: Switches, jumpers and buttons of EVK-R10 new model

4.1.3 LEDs

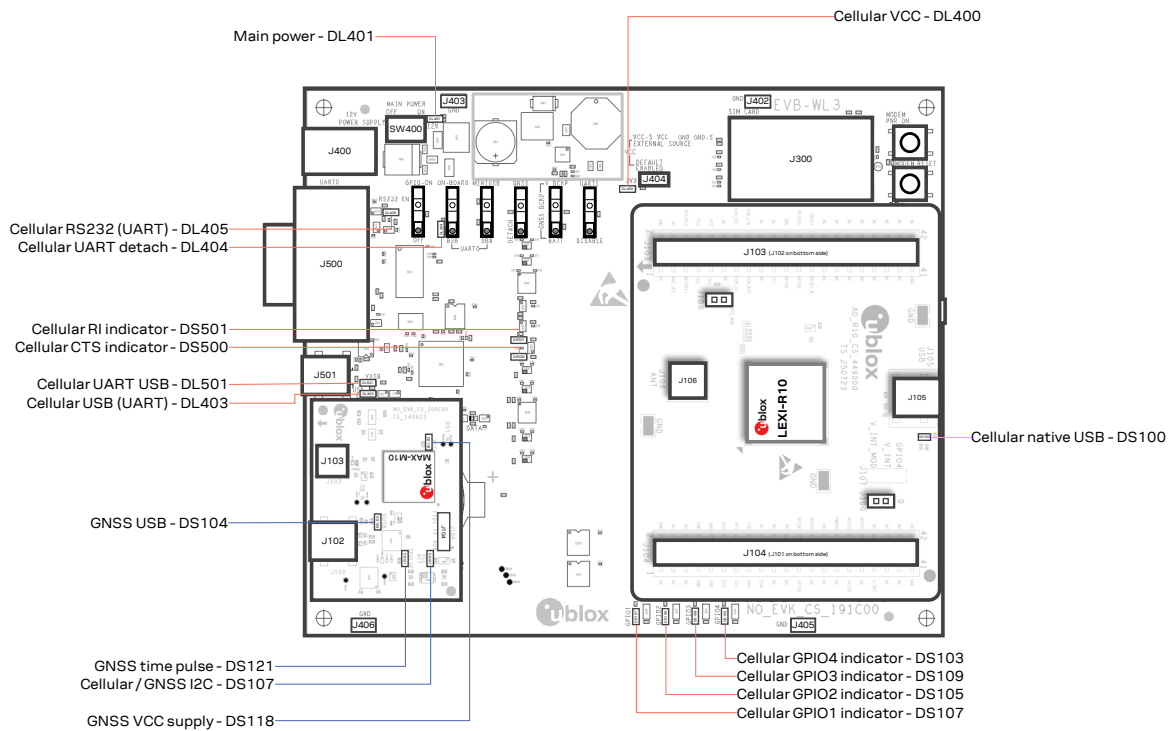

Function	Color	Description	LED #	Board
Main power		Power supply plugged in the 9 - 18 V power input	DL401	EVB-WL3
Cellular VCC		Cellular module supplied; main power switch must be switched on	DL400	EVB-WL3
Cellular UART USB		USB cable plugged in J501 for UART access	DL501	EVB-WL3
Cellular USB (UART)		Green light on when UART is routed to J501 Red light blinks at UART TX or RX data on J501	DL403	EVB-WL3
Cellular UART detach		UART signals are available only on ADP-R10	DL404	EVB-WL3
Cellular RS232 (UART)		Green light on when UART is routed to J500 Red light blinks at UART TX or RX data on J500	DL405	EVB-WL3
Cellular RI indicator		RI line turns ON (active low)	DS501	EVB-WL3
Cellular CTS indicator		CTS line turns ON (active low)	DS500	EVB-WL3
Cellular GPIO1 indicator		Green light on when cellular GPIO1 is high	DS107	EVB-WL3
Cellular GPIO2 indicator		Green light on when cellular GPIO2 is high	DS105	EVB-WL3
Cellular GPIO3 indicator		Green light on when cellular GPIO3 is high	DS109	EVB-WL3
Cellular GPIO4 indicator		Green light on when cellular GPIO4 is high	DS103	EVB-WL3
Cellular native USB		USB cable plugged in J105 on ADP-R10	DS100	ADP-R10
GNSS VCC supply		MAX-M10S GNSS module supply is turned on	DS118	ADP-GNSS
GNSS USB		USB cable plugged in J102 on ADP-GNSS	DS104	ADP-GNSS
GNSS time pulse		MAX-M10S GNSS time pulse	DS121	ADP-GNSS
Cellular / GNSS I2C		Cellular / GNSS module communication over the I2C interface	DS107	ADP-GNSS

Table 6: LEDs of EVK-R10 new model

4.1.4 Connectors

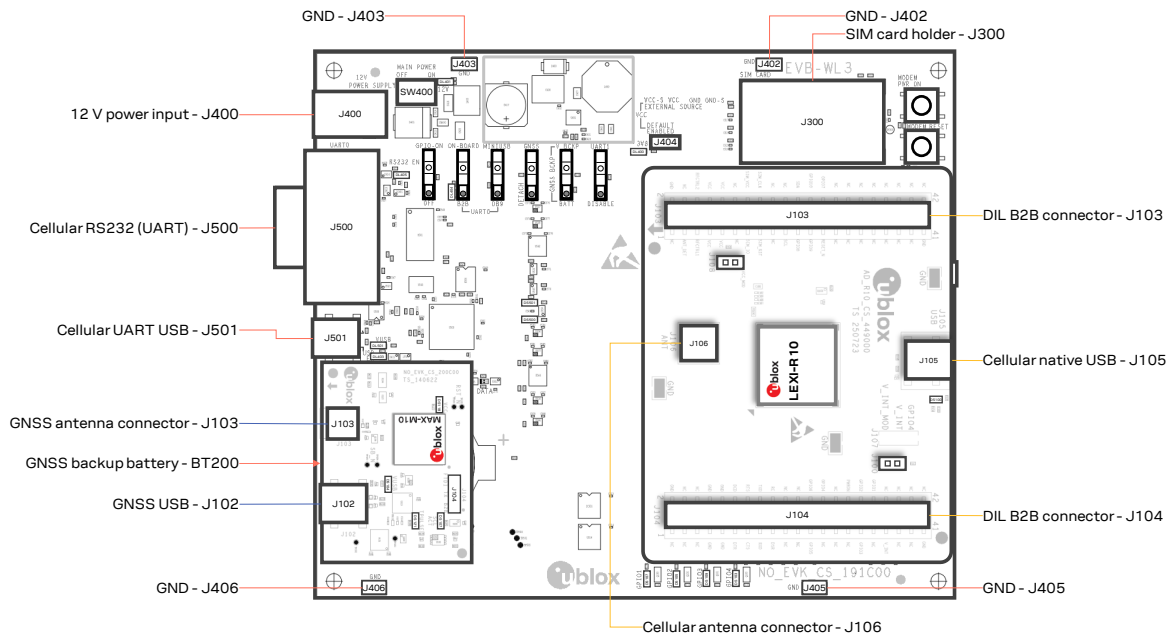

Function	Description	Name	Board
9 - 18 V power input	Connector for the AC / DC power adapter of EVK AC: 100-240 V, 0.8 A, 50-60 Hz / DC: +12 V, 2.5 A	J400	EVB-WL3
SIM card holder	SIM card holder (mini-SIM 2FF)	J300	EVB-WL3
Cellular USB (UART)	Mini-USB connector for the cellular UART interface converted as USB interface	J501	EVB-WL3
Cellular RS232 (UART)	DB9 connector for the cellular UART interface converted as RS232 interface	J500	EVB-WL3
GNSS backup battery	Backup battery socket for the GNSS module (under ADP-GNSS board)	BT200	EVB-WL3
GND	Ground terminals for the probe reference	J402, J403 J405, J406	EVB-WL3
Cellular antenna	SMA connector for the cellular antenna (ANT)	J106	ADP-R10
Cellular native USB	Mini-USB connector for the cellular native USB interface	J105	ADP-R10
DIL B2B headers	Dual-in-line board-to-board connectors for cellular module interfaces	J103, J104	ADP-R10
GNSS antenna	SMA connector for the GNSS antenna to be connected to the GNSS RF input of the MAX-M10S GNSS module (RF_IN)	J103	ADP-GNSS
GNSS USB	Mini-USB connector for the GNSS module UART interface converted as USB interface	J102	ADP-GNSS

Table 7: Connectors of EVK-R10 new model

- ⚠ In the unlikely event of a failure in the internal protection circuitry, there is a risk of an explosion when charging a fully or a partially discharged battery. Replace the battery when it no longer has sufficient charge for unit operation. Check the battery before use if the device has not been used for an extended period.
- ⚠ Risk of explosion if the battery is replaced with an incorrect type. Dispose battery according to rules!

4.1.5 Pin out

Table 8 lists the pins / interfaces of the LEXI-R10 modules, as routed up to the 42-pin dual-in-line board-to-board header connectors (**J103** and **J104**) available on the ADP-R10 adapter board of the evaluation kit.

LEXI-R10 module			Connector	LEXI-R10 module			Connector
Pin no.	Pin ID	Signal name	Name / pin number	Pin no.	Pin ID	Signal name	Name / pin number
1	B1	GND	J104 pins 7-10	27	P15	PWR_ON	J104 pin 30
2	C1	RSVD	Not available	28	N15	RESET_N	J103 pin 25
3	D1	GND	J104 pins 7-10	29	M15	GPIO6	J104 pin 24
4	E1	RXD	J104 pin 15	30	L15	SIM_RST	J103 pin 15
5	F1	TXD	J104 pin 16	31	K15	SIM_CLK	J103 pin 16
6	G1	CTS	J104 pin 13	32	J15	SIM_IO	J103 pin 13
7	H1	RTS	J104 pin 14	33	H15	VSIM	J103 pin 14
8	J1	DCD	J104 pin 12	34	G15	RSVD	Not available
9	K1	DTR	J104 pin 11	35	F15	RSVD	Not available
10	L1	RI	J104 pin 18	36	E15	RSVD	Not available
11	M1	DSR	J104 pin 17	37	D15	RSVD	Not available
12	N1	SCL	J103 pin 19	38	C15	RSVD	Not available
13	P1	SDA	J103 pin 22	39	B15	RSVD	Not available
14	R2	GPIO1	J104 pin 34	40	A14	VCC	J103 pins 7-10
15	R3	GPIO2	J104 pin 32	41	A13	VCC	J103 pins 7-10
16	R4	GPIO3	J104 pin 31	42	A12	VCC	J103 pins 7-10
17	R5	GPIO4	J104 pin 26	43	A11	V_INT	J104 pin 35
18	R6	GPIO5	J104 pin 23	44	A10	RFCTRL2	J103 pin 6
19	R7	RSVD	Not available	45	A9	RFCTRL1	J103 pin 5
20	R8	USB_D-	Not available	46	A8	RSVD	Not available
21	R9	USB_D+	Not available	47	A7	RSVD	Not available
22	R10	RSVD	Not available	48	A6	USB_BOOT	Not available
23	R11	GPIO7	J103 pin 26	49	A5	ANT_DET	J103 pin 3
24	R12	GPIO8	J103 pin 21	50	A4	GND	J104 pins 7-10
25	R13	GPIO9	J103 pin 23	51	A3	ANT	Not available
26	R14	GPIO10	J103 pin 24	52	A2	GND	J104 pins 7-10

Table 8: Interfaces of LEXI-R10 modules on EVK-R10 new model

Dual-in-line board-to-board connector J104				Dual-in-line board-to-board connector J103			
Signal name	Pin no.	Pin no.	Signal name	Signal name	Pin no.	Pin no.	Signal name
Not connected	1	2	GND	Not connected	1	2	GND
Not connected	3	4	Not connected	ANT_DET	3	4	Not connected
Not connected	5	6	Not connected	RFCTRL1	5	6	RFCTRL2
GND	7	8	GND	VCC	7	8	VCC
GND	9	10	GND	VCC	9	10	VCC
DTR	11	12	DCD	Not connected	11	12	Not connected
CTS	13	14	RTS	SIM_IO	13	14	VSIM
RXD	15	16	TXD	SIM_RST	15	16	SIM_CLK
DSR	17	18	RI	Not connected	17	18	Not connected
Not connected	19	20	Not connected	SCL	19	20	Not connected
Not connected	21	22	Not connected	GPIO8	21	22	SDA
GPIO5	23	24	GPIO6	GPIO9	23	24	GPIO10
Not connected	25	26	GPIO4	RESET_N	25	26	GPIO7
Not connected	27	28	Not connected	Not connected	27	28	Not connected
Not connected	29	30	PWR_ON	Not connected	29	30	Not connected
GPIO3	31	32	GPIO2	Not connected	31	32	Not connected
Not connected	33	34	GPIO1	Not connected	33	34	Not connected
V_INT	35	36	Not connected	Not connected	35	36	Not connected
Not connected	37	38	Not connected	Not connected	37	38	Not connected
Not connected	39	40	Not connected	Not connected	39	40	Not connected
GND	41	42	Not connected	GND	41	42	Not connected

Table 9: Pin-out of the 42-pin dual-in-line board-to-board connectors (J103, J104) on EVK-R10 new model

 The pins / interfaces that are not supported by LEXI-R10 modules should not be driven by an external device. See the data sheet [2] and the system integration manual [3] to learn about the features supported by LEXI-R10 modules.

4.1.6 Current consumption measurement

To measure the current consumption of LEXI-R10 modules, remove the jumper socket from the cellular VCC supply jumper **J108** on the ADP-R10 board, as shown in [Figure 10](#).

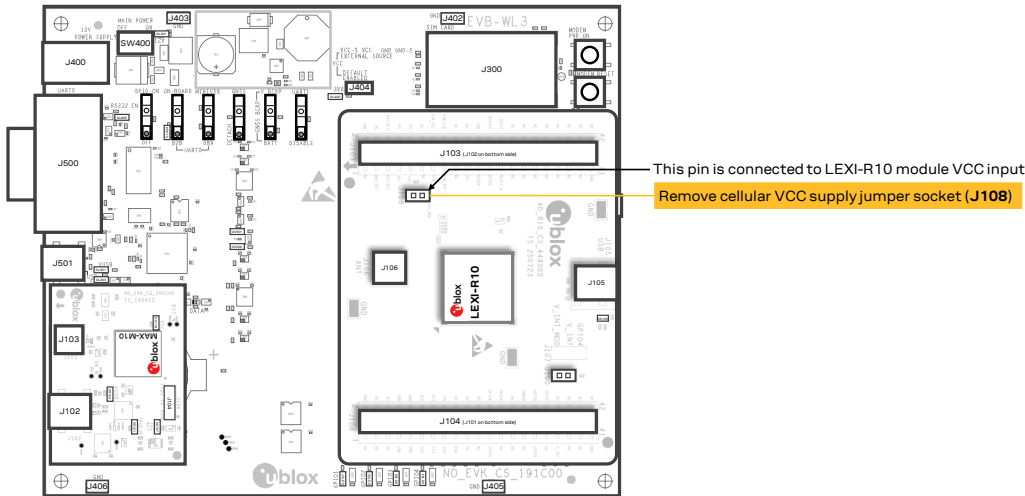

Figure 10: Jumper socket to be removed for LEXI-R10 module's current consumption measurement on EVK-R10 new model

A suitable external digital multi-meter (as the Keysight 34465A, 34410A or 34411A) can be used for current consumption measurements: in this example, the 3.8 V supply circuit on the EVB-WL3 will supply the cellular module, with the digital multi-meter placed in series as illustrated in [Figure 11](#).

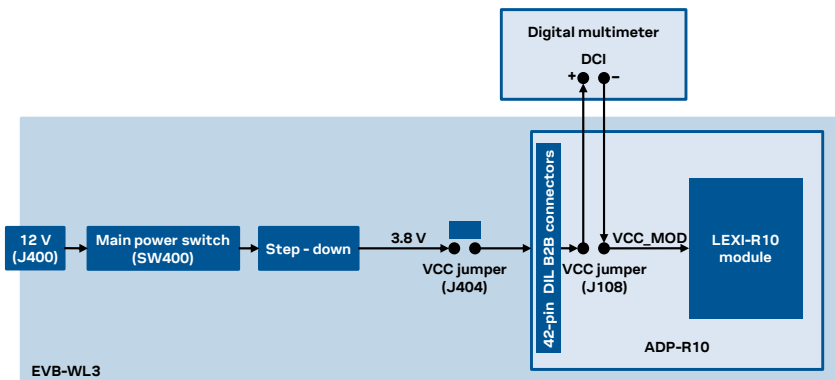

Figure 11: Setup for cellular module's current consumption measurement using a current meter with EVK-R10 new model

Alternatively, a suitable external DC power supply with dynamic current measurement capabilities (e.g., the portable and cheap Qoitech Otii Arc, or the more accurate Keysight N6705B, or the models designed for mobile communications Keysight 66319B/D or 66321B/D) can be used, acting also as 3.8 V supply source for the cellular module mounted on the adapter board, as illustrated in [Figure 12](#).

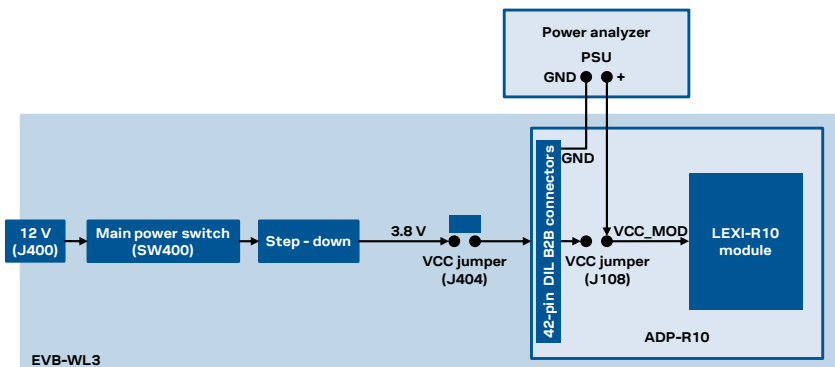

Figure 12: Setup for module's current consumption measurement using a DC power analyzer with EVK-R10 new model

4.2 EVK-R10 old model

4.2.1 Block diagram and basic description

Figure 13 shows the main interfaces and internal connections of the EVK-R10 evaluation kit:

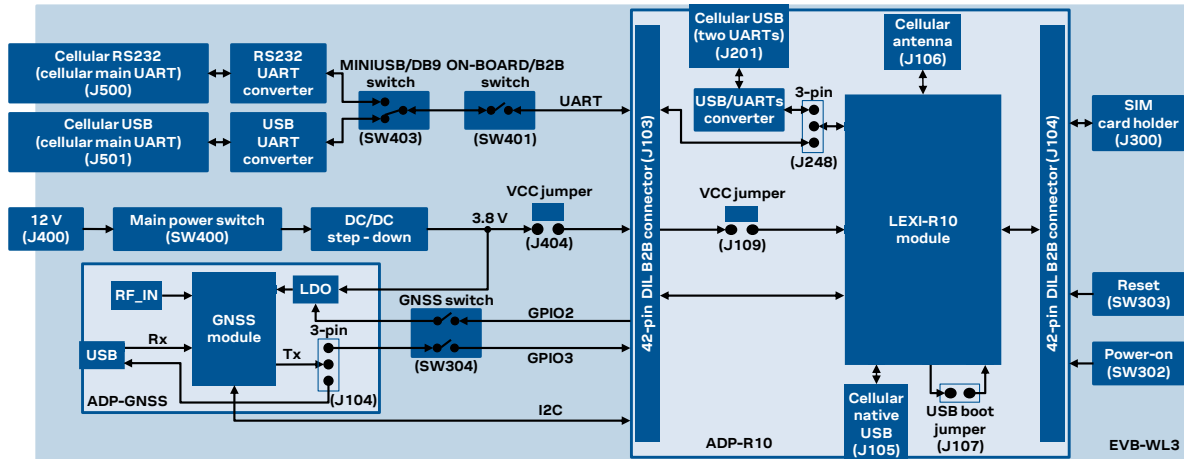

Figure 13: Block diagram of EVK-R10 old model

The ADP-R10 and the ADP-GNSS are connected by male header board-to-board connectors on the bottom of the adapter boards and their corresponding female connectors on top of the EVB-WL3.

As illustrated in section 2.1.2.3 and summarized in Table 4, for communication via the UART interfaces of the cellular module, the following connections are allowed and can be alternatively enabled in a mutually exclusive way:

1. If the ON-BOARD / B2B switch (**SW401**) on the EVB-WL3 board is set to “ON-BOARD” and if a jumper socket is inserted on the pin 1 and pin 2 of the 3-pin header **J248** on the cellular adapter board (see Figure 14), then the main UART interface of the LEXI-R10 module, routed through the DIL header board-to-board connectors mounted on the bottom of the cellular adapter board, can be accessed as converted to USB interface on the USB connector (**J501**) on the EVB-WL3 board, or it can be accessed as converted to RS232 interface on the RS232 DB9 connector (**J500**) on the EVB-WL3 board, according to the MINIUSB / DB9 switch (**SW403**) setting.
2. If the ON-BOARD / B2B switch (**SW401**) on the EVB-WL3 board is set to “B2B” and if a jumper socket is inserted on the pin 2 and pin 3 of the 3-pin header **J248** on the cellular adapter board (see Figure 14), the UART interfaces of LEXI-R10 module can be accessed as USB interfaces on the USB connector (**J201**) on the cellular adapter board.
3. If the ON-BOARD / B2B switch (**SW401**) on the EVB-WL3 board is set to “B2B” and if there is no jumper socket inserted on the 3-pin header **J248** on the cellular adapter board (see Figure 14), then the UART interface(s) of the LEXI-R10 module can be accessed at 1.8 V CMOS signal levels on the DIL header connector mounted on the top of the cellular adapter board, to communicate, for example, with an external MCU.

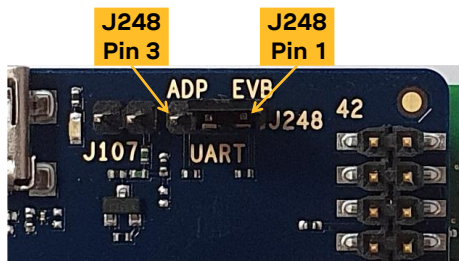
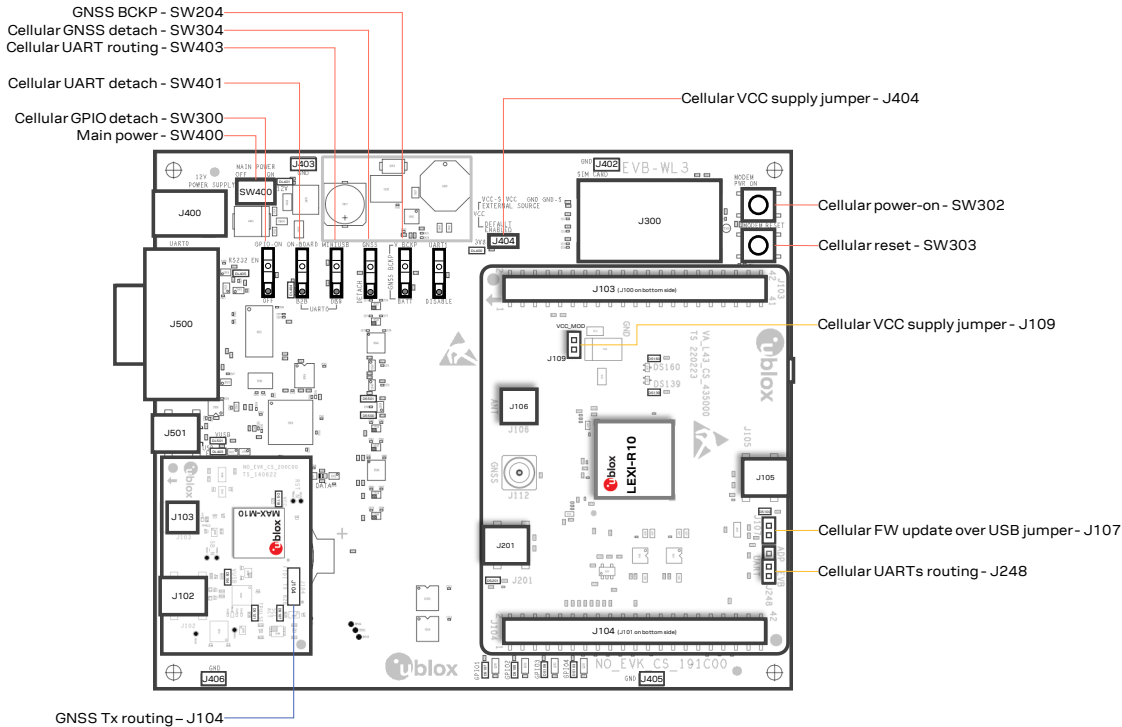

Figure 14: 3-pin header J248 available to set the routing of the UART interfaces on EVK-R10 old model

The USB interface of the cellular module is available on the native USB connector (**J105**) mounted on the cellular adapter board. Other LEXI-R10 peripherals are available on the dual-in-line male board-to-board connectors (**J103** and **J104**) provided on the top layer of the cellular adapter board.

4.2.2 Switches, jumpers, and buttons



Function	Description	Name	Board
Main power switch	Power on / off the whole evaluation kit	SW400	EVB-WL3
Cellular VCC	Jumper socket to provide the 3.8 V supply to the cellular VCC input	J404	EVB-WL3
		J109	ADP-R10
Cellular power-on	Push button to switch on / off LEXI-R10 modules	SW302	EVB-WL3
Cellular reset	Push button to reset LEXI-R10 modules	SW303	EVB-WL3
Cellular UART detach	Slide switch to attach / detach cellular main UART from USB / RS232 connectors	SW401	EVB-WL3
Cellular UART routing	Slide switch to select cellular main UART routing on USB or RS232 connector	SW403	EVB-WL3
Cellular UARTs routing	3-pin header jumper to route cellular UART(s) interfaces to the USB two UARTs connector on the ADP-R10, or over the USB or RS232 connectors on the EVB-WL3, or over the DIL B2B connector on the ADP-R10	J248	ADP-R10
Cellular GPIO detach	Slide switch to attach / detach the cellular GPIOs from peripherals: when detached, the signals are available only on DIL B2B connector on ADP-R10	SW300	EVB-WL3
Cellular GNSS detach	Slide switch to attach / detach the cellular system to the GNSS module mounted on the ADP-GNSS: when detached, signals are available only on DIL B2B connector on ADP-R10 board	SW304	EVB-WL3
GNSS BCKP	Slide switch to connect / disconnect backup battery to V_BCKP pin of the GNSS module mounted on the ADP-GNSS	SW204	EVB-WL3
FW update over USB	Jumper socket to execute the FW update of the LEXI-R10 module over USB	J107	ADP-R10
GNSS Tx routing	3-pin header jumper to route and make accessible GNSS UART Tx over the USB connector on the ADP-GNSS or to use it as Tx data ready for the cellular module	J104	ADP-GNSS

Table 10: Switches, jumpers and buttons of EVK-R10 old model

4.2.3 LEDs

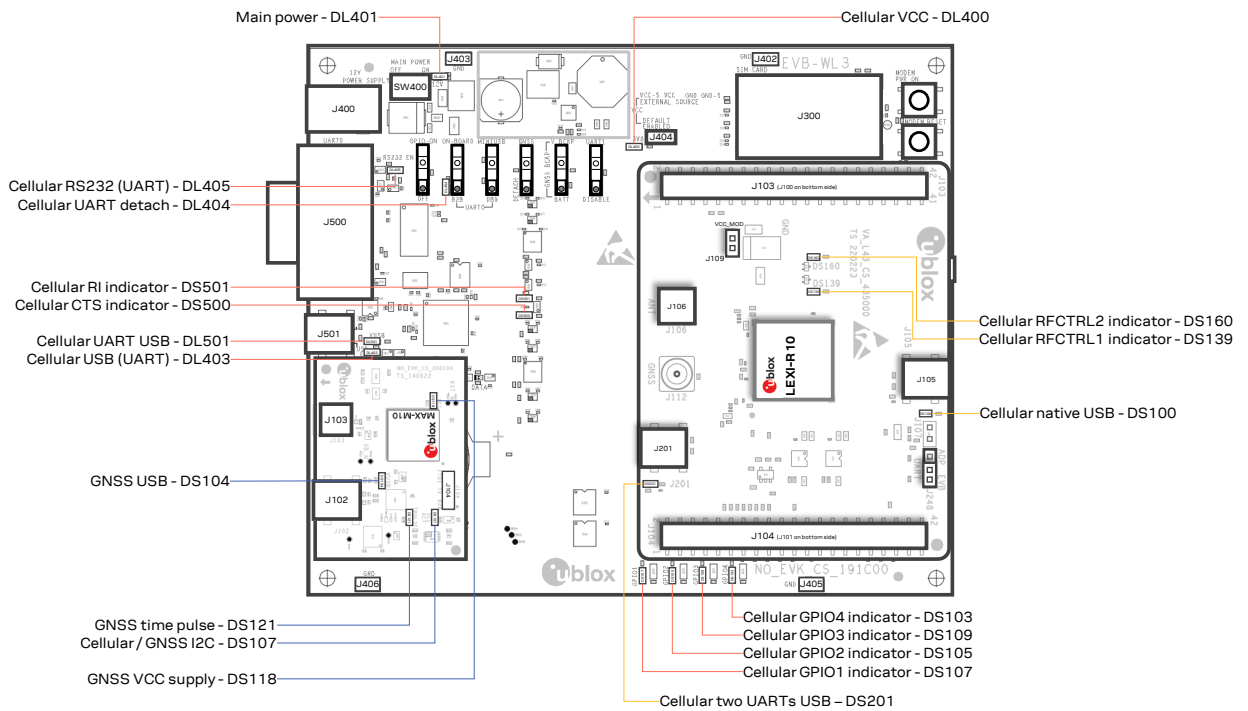

Function	Color	Description	LED #	Board
Main power	Blue	Power supply plugged in the 9 - 18 V power input	DL401	EVB-WL3
Cellular VCC	Green	Cellular module supplied; main power switch must be switched on	DL400	EVB-WL3
Cellular UART USB	Blue	USB cable plugged in J501 for UART access	DL501	EVB-WL3
Cellular USB (UART)	Red	Green light on when UART is routed to J501 Red light blinks at UART TX or RX data on J501	DL403	EVB-WL3
Cellular UART detach	Green	UART signals are available only on ADP-R10	DL404	EVB-WL3
Cellular RS232 (UART)	Red	Green light on when UART is routed to J500 Red light blinks at UART TX or RX data on J500	DL405	EVB-WL3
Cellular RI indicator	Red	RI line turns ON (active low)	DS501	EVB-WL3
Cellular CTS indicator	Green	CTS line turns ON (active low)	DS500	EVB-WL3
Cellular GPIO1 indicator	Green	Green light on when cellular GPIO1 is high	DS107	EVB-WL3
Cellular GPIO2 indicator	Green	Green light on when cellular GPIO2 is high	DS105	EVB-WL3
Cellular GPIO3 indicator	Green	Green light on when cellular GPIO3 is high	DS109	EVB-WL3
Cellular GPIO4 indicator	Green	Green light on when cellular GPIO4 is high	DS103	EVB-WL3
Cellular RFCTRL1 indicator	Green	Green light on when cellular RFCTRL1 is high	DS139	ADP-R10
Cellular RFCTRL2 indicator	Red	Red light on when cellular RFCTRL2 is high	DS160	ADP-R10
Cellular native USB	Blue	USB cable plugged in J105 on ADP-R10	DS100	ADP-R10
Cellular two UARTs USB	Blue	USB cable plugged in J201 on ADP-R10	DS201	ADP-R10
GNSS VCC supply	Green	MAX-M10S GNSS module supply is turned on	DS118	ADP-GNSS
GNSS USB	Blue	USB cable plugged in J102 on ADP-GNSS	DS104	ADP-GNSS
GNSS time pulse	Green	MAX-M10S GNSS time pulse	DS121	ADP-GNSS
Cellular / GNSS I2C	Yellow	Cellular / GNSS module communication over the I2C interface	DS107	ADP-GNSS

Table 11: LEDs of EVK-R10 old model

4.2.4 Connectors

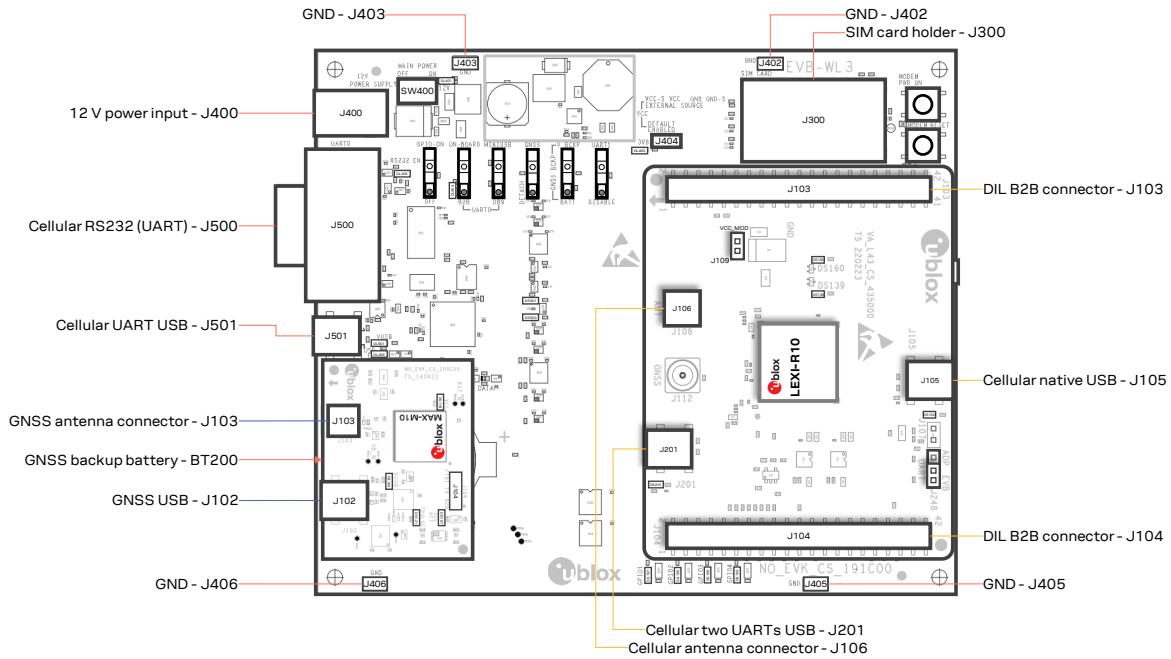

Function	Description		Name	Board
9 - 18 V power input	Connector for the AC / DC power adapter of EVK AC: 100-240 V, 0.8 A, 50-60 Hz / DC: +12 V, 2.5 A		J400	EVB-WL3
SIM card holder	SIM card holder (mini-SIM 2FF)		J300	EVB-WL3
Cellular USB (UART)	Mini-USB connector for the cellular UART interface converted as USB interface		J501	EVB-WL3
Cellular RS232 (UART)	DB9 connector for the cellular UART interface converted as RS232 interface		J500	EVB-WL3
GNSS backup battery	Backup battery socket for the GNSS module (under ADP-GNSS board)		BT200	EVB-WL3
GND	Ground terminals for the probe reference		J402, J403 J405, J406	EVB-WL3
Cellular antenna	SMA connector for the cellular antenna (ANT)		J106	ADP-R10
Cellular native USB	Mini-USB connector for the cellular native USB interface		J105	ADP-R10
Cellular two UARTs USB	Mini-USB connector for the cellular two UART interfaces converted as USB interfaces		J201	ADP-R10
DIL B2B headers	Dual-in-line board-to-board connectors for cellular module interfaces		J103, J104	ADP-R10
GNSS antenna	SMA connector for the GNSS antenna to be connected to the GNSS RF input of the MAX-M10S GNSS module (RF_IN)		J103	ADP-GNSS
GNSS USB	Mini-USB connector for the GNSS module UART interface converted as USB interface		J102	ADP-GNSS

Table 12: Connectors of EVK-R10 old model

- In the unlikely event of a failure in the internal protection circuitry, there is a risk of an explosion when charging a fully or a partially discharged battery. Replace the battery when it no longer has sufficient charge for unit operation. Check the battery before use if the device has not been used for an extended period.
- Risk of explosion if the battery is replaced with an incorrect type. Dispose battery according to rules!

4.2.5 Pin out

Table 13 lists the pins / interfaces of the LEXI-R10 modules, as routed up to the 42-pin dual-in-line board-to-board header connectors (**J103** and **J104**) available on the ADP-R10 adapter board of the evaluation kit.

LEXI-R10 module			Connector	LEXI-R10 module			Connector
Pin no.	Pin ID	Signal name	Name / pin number	Pin no.	Pin ID	Signal name	Name / pin number
1	B1	GND	J104 pins 7-10	27	P15	PWR_ON	J104 pin 30
2	C1	RSVD	Not available	28	N15	RESET_N	J103 pin 25
3	D1	GND	J104 pins 7-10	29	M15	GPIO6	J104 pin 24
4	E1	RXD	J104 pin 15	30	L15	SIM_RST	J103 pin 15
5	F1	TXD	J104 pin 16	31	K15	SIM_CLK	J103 pin 16
6	G1	CTS	J104 pin 13	32	J15	SIM_IO	J103 pin 13
7	H1	RTS	J104 pin 14	33	H15	VSIM	J103 pin 14
8	J1	DCD	J104 pin 12	34	G15	RSVD	Not available
9	K1	DTR	J104 pin 11	35	F15	RSVD	Not available
10	L1	RI	J104 pin 18	36	E15	RSVD	Not available
11	M1	DSR	J104 pin 17	37	D15	RSVD	Not available
12	N1	SCL	J103 pin 19	38	C15	RSVD	Not available
13	P1	SDA	J103 pin 22	39	B15	RSVD	Not available
14	R2	GPIO1	J104 pin 34	40	A14	VCC	J103 pins 7-10
15	R3	GPIO2	J104 pin 32	41	A13	VCC	J103 pins 7-10
16	R4	GPIO3	J104 pin 31	42	A12	VCC	J103 pins 7-10
17	R5	GPIO4	J104 pin 26	43	A11	V_INT	J104 pin 35
18	R6	GPIO5	J104 pin 23	44	A10	RFCTRL2	J103 pin 6
19	R7	RSVD	J104 pin 4	45	A9	RFCTRL1	J103 pin 5
20	R8	USB_D-	Not available	46	A8	RSVD	Not available
21	R9	USB_D+	Not available	47	A7	RSVD	J104 pin 22
22	R10	RSVD	Not available	48	A6	USB_BOOT	Not available
23	R11	GPIO7	J103 pin 26	49	A5	ANT_DET	Not available
24	R12	GPIO8	J103 pin 21	50	A4	GND	J104 pins 7-10
25	R13	GPIO9	J103 pin 23	51	A3	ANT	Not available
26	R14	GPIO10	J103 pin 24	52	A2	GND	J104 pins 7-10

Table 13: Interfaces of LEXI-R10 modules on EVK-R10 old model

Dual-in-line board-to-board connector J104				Dual-in-line board-to-board connector J103			
Signal name	Pin no.	Pin no.	Signal name	Signal name	Pin no.	Pin no.	Signal name
Not connected	1	2	GND	Not connected	1	2	GND
Not connected	3	4	RSVD #19	Not connected	3	4	Not connected
Not connected	5	6	Not connected	RFCTRL1	5	6	RFCTRL2
GND	7	8	GND	VCC	7	8	VCC
GND	9	10	GND	VCC	9	10	VCC
DTR	11	12	DCD	Not connected	11	12	Not connected
CTS	13	14	RTS	SIM_IO	13	14	VSIM
RXD	15	16	TXD	SIM_RST	15	16	SIM_CLK
DSR	17	18	RI	Not connected	17	18	Not connected
Not connected	19	20	Not connected	SCL	19	20	Not connected
Not connected	21	22	RSVD #47	GPIO8	21	22	SDA
GPIO5	23	24	GPIO6	GPIO9	23	24	GPIO10
Not connected	25	26	GPIO4	RESET_N	25	26	GPIO7
Not connected	27	28	Not connected	Not connected	27	28	Not connected
Not connected	29	30	PWR_ON	Not connected	29	30	Not connected
GPIO3	31	32	GPIO2	Not connected	31	32	Not connected
Not available	33	34	GPIO1	Not connected	33	34	Not connected
V_INT	35	36	Not connected	Not connected	35	36	Not connected
Not connected	37	38	Not connected	Not connected	37	38	Not connected
Not connected	39	40	Not connected	Not connected	39	40	Not connected
GND	41	42	Not connected	GND	41	42	Not connected

Table 14: Pin-out of the 42-pin dual-in-line board-to-board connectors (J103, J104) on EVK-R10 old model

 The pins / interfaces that are not supported by LEXI-R10 modules should not be driven by an external device. See the data sheet [2] and the system integration manual [3] to learn about the features supported by LEXI-R10 modules.

4.2.6 Current consumption measurement

To measure the current consumption of LEXI-R10 modules, remove the jumper socket from the cellular VCC supply jumper **J109** on the ADP-R10 board, as shown in [Figure 15](#).

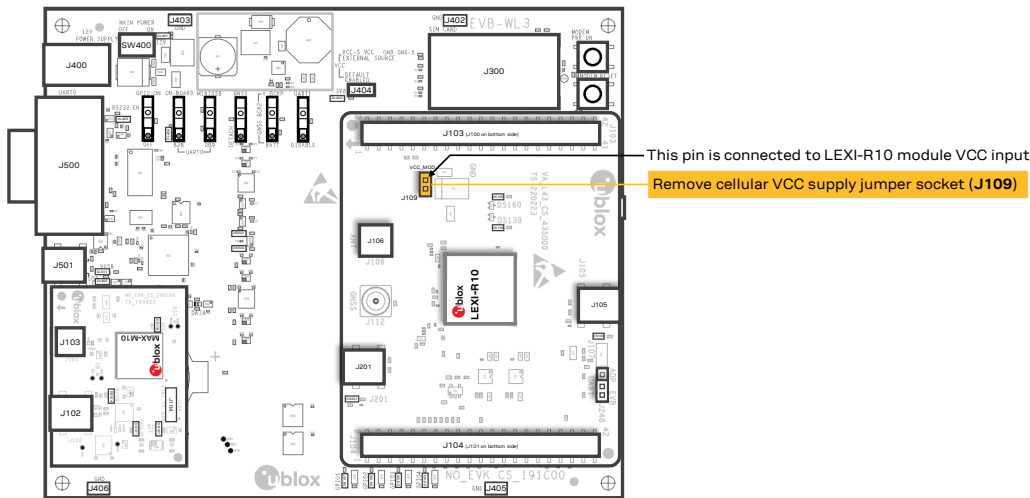

Figure 15: Jumper socket to be removed for LEXI-R10 module's current consumption measurement on EVK-R10 old model

A suitable external digital multi-meter (as the Keysight 34465A, 34410A or 34411A) can be used for current consumption measurements: in this example, the 3.8 V supply circuit on the EVB-WL3 will supply the cellular module, with the digital multi-meter placed in series as illustrated in [Figure 16](#).

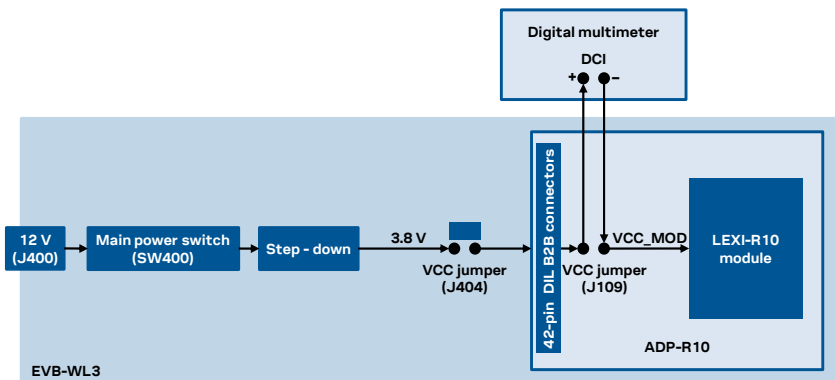

Figure 16: Setup for cellular module's current consumption measurement using a current meter with EVK-R10 old model

Alternatively, a suitable external DC power supply with dynamic current measurement capabilities (e.g., the portable and cheap Qoitech Otii Arc, or the more accurate Keysight N6705B, or the models designed for mobile communications Keysight 66319B/D or 66321B/D) can be used, acting also as 3.8 V supply source for the cellular module mounted on the adapter board, as illustrated in [Figure 17](#).

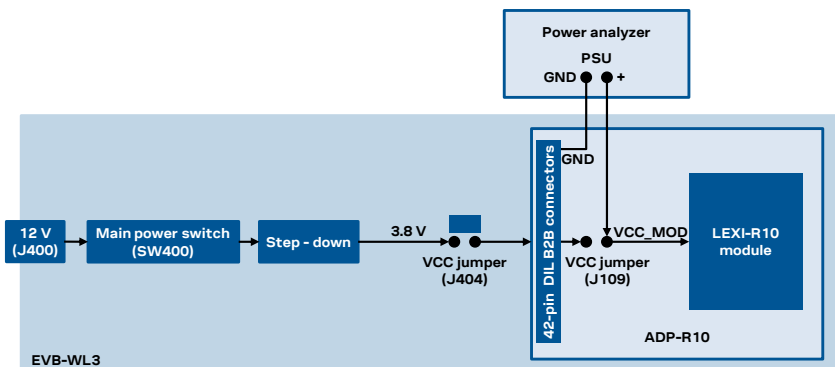

Figure 17: Setup for cellular module's current consumption measurement using a DC power analyzer with EVK-R10 old model

Appendix

A Setting up AT terminal communication

The u-blox m-center cellular module evaluation tool is a powerful platform for evaluating, configuring and testing u-blox cellular products. m-center includes an AT commands terminal for communication with the device and can be downloaded for free from <https://www.u-blox.com/en/product/m-center>. For m-center example scripts, visit <https://github.com/u-blox/m-center>.

1. Follow the board setup instructions in section 2 to provide all the required connections and switching on the cellular module.
2. Run the u-blox m-center tool: after the m-center start-up, the **Home** page appears, as shown in Figure 18.

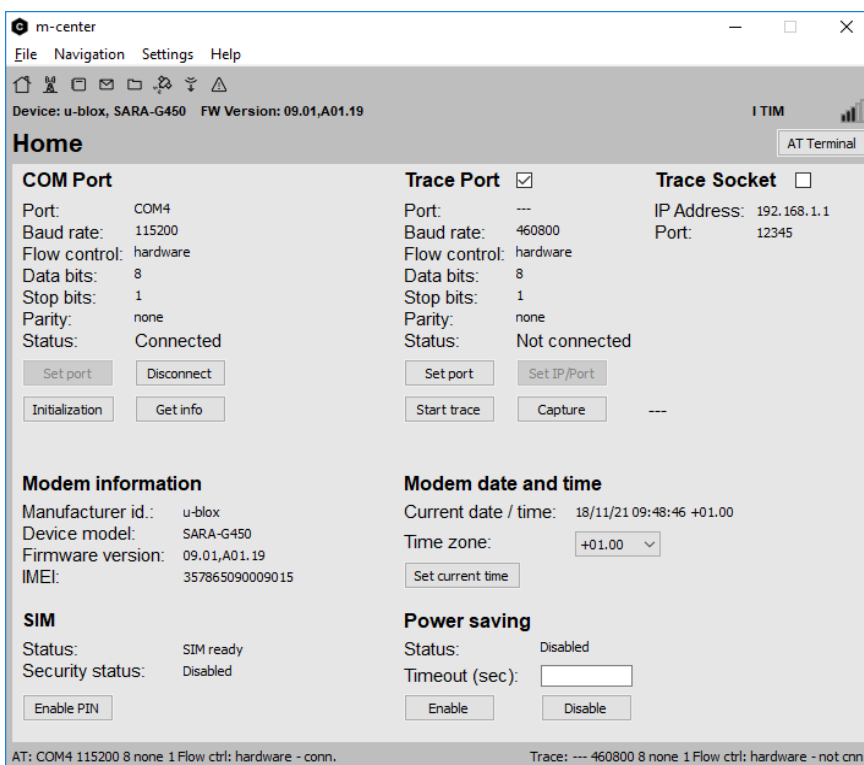

Figure 18: m-center Home page

3. On the **Home** page, set up the AT COM port with setting values below:
 - o Data rate: 115200 bit/s
 - o Data bits: 8
 - o Parity: N
 - o Stop bits: 1
 - o Flow control: HW
4. Check in the Windows Device Manager to find out which specific COM port is being used by the EVK-R10.
5. Enable the connection to u-blox cellular module by clicking on the **Connect** button.
6. Retrieve the module and network information by clicking on the **Get info** button.
7. The module information is retrieved and displayed on the **Home** page.

8. Click on the **AT Terminal** button, found at the upper right of the **Home** page. A new window opens, and the AT command terminal is now ready for communication with the EVK-R10.

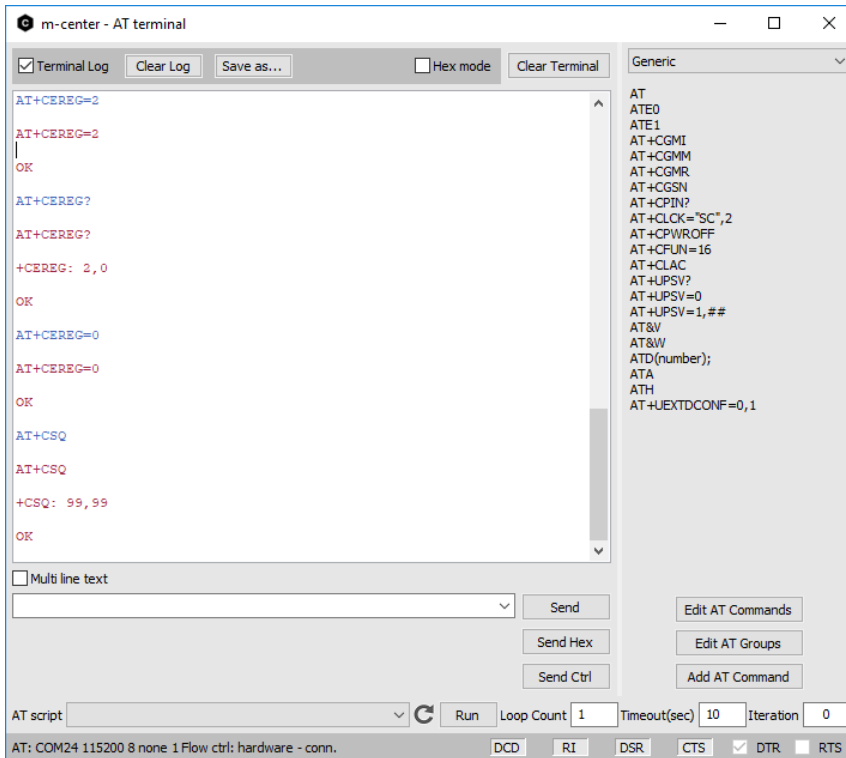

Figure 19: AT terminal window

For more information on using the u-blox m-center, press the **F1** key to open the m-center help window on the computer.

For the complete list of the AT commands supported by the modules and their syntax, see the AT commands manual [1].

B Glossary

Abbreviation	Definition
AC	Alternating current
ADC	Analog to Digital Converter
ADP	Adapter Board
APN	Access Point Name
AT	AT Command Interpreter Software Subsystem, or attention
B2B	Board-To-Board
CTS	Clear To Send
DC	Direct current
DCD	Data Carrier Detect
DCE	Data Communication Equipment
DIL	Dual In Line
DSR	Data Set Ready
DTE	Data Terminal Equipment
DTR	Data Terminal Ready
EVB	Evaluation Board
EVK	Evaluation Kit
GND	Ground
GNSS	Global Navigation Satellite System
GPIO	General Purpose Input Output
HW	Hardware
I2C	Inter-Integrated Circuit
IoT	Internet of Things
IP	Internet Protocol
LED	Light Emitting Diode
LTE	Long Term Evolution
MCU	Micro-Controller Unit
NB	Narrow Band
PDP	Packet Data Protocol
PSU	Power Supply Unit
RAT	Radio Access Technology
RF	Radio Frequency
RI	Ring Indicator
RTS	Request To Send
Rx	Receiver
SIM	Subscriber Identity Module
SMA	SubMiniature version A
TCP	Transfer Control Protocol
Tx	Transmitter
UART	Universal Asynchronous Receiver-Transmitter serial interface

Related documentation

- [1] u-blox LEXI-R10 series AT commands manual, [UBXDOC-686885345-1786](#)
- [2] u-blox LEXI-R10 series data sheet, [UBX-23007594](#)
- [3] u-blox LEXI-R10 series system integration manual, [UBX-23008149](#)
- [4] u-blox LEXI-R10 series application development guide, [UBXDOC-686885345-1983](#)



For product change notifications and regular updates of u-blox documentation, register on our website, www.u-blox.com.

Revision history

Revision	Date	Name	Comments
R01	21-Feb-2024	sses	Initial release
R02	05-Jun-2024	yatu	Minor editing
R03	31-Jul-2024	fvid / sses	Extended applicability to EVK-LEXI-R10001D. Added description of the “new” version of the cellular adapter board design.

Contact

u-blox AG

Address: Zürcherstrasse 68
8800 Thalwil
Switzerland

For further support and contact information, visit us at www.u-blox.com/support.

X-ON Electronics

Largest Supplier of Electrical and Electronic Components

Click to view similar products for [Mobile Development Tools](#) category:

Click to view products by [U-Blox](#) manufacturer:

Other Similar products are found below :

[5G-SOC-EVB-KIT](#) [MIKROE-5124](#) [EVK-R422M8S-0](#) [76002147](#) [ADP-SARA-R500E-01](#) [6000648](#) [6001457](#) [MIKROE-2535](#) [1946](#) [1963](#)
[2687](#) [2691](#) [XK3-C-G1-UT-W](#) [XK3-C-G4-UT-W](#) [XK3-C-GM2-UT-W](#) [MIKROE-4118](#) [MIKROE-1298](#) [MIKROE-1375](#) [MIKROE-1720](#)
[MIKROE-3294](#) [MIKROE-4506](#) [MIKROE-5991](#) [MIKROE-6256](#) [MIKROE-6277](#) [MIKROE-6318](#) [EG800QEULC-N03-TA0AA](#) [109030001](#)
[109030002](#) [Monarch 2 NEKTAR-B-GM02S](#) [Monarch 2 NEKTAR-B-GM02SP](#) [Monarch-Go-STK](#) [Monarch-Go-GPS-STK](#) [6001458](#)
[SKY68001-31EK1](#) [CEL-13120](#) [CEL-14997](#) [KIT-21229](#) [WRL-20409](#) [ADP-LEXI-R520-02](#) [ADP-R10801D-00](#) [ADP-R8001-00C](#) [ADP-](#)
[R8001M10-00C](#) [ADP-SARA-R520-02](#) [ADP-SARA-R520M10-02](#) [ADP-LEXI-R422-01](#) [EVK-LEXI-R422-01](#) [EVK-R10801D-00](#) [EVK-](#)
[R422M10S-0](#) [EVK-R8001-00C](#) [EVK-R8001M10-00C](#)