

BMD-380

Stand-alone Bluetooth 5 low energy and IEEE 802.15.4 module

Data sheet



Abstract

This technical data sheet describes the BMD-380 stand-alone Bluetooth® low energy and IEEE 802.15.4 module. The OEMs can embed their own application on top of the integrated Bluetooth low energy stack using Nordic Semiconductor SDK integrated development environment (IDE).

Document information

Title	BMD-380	
Subtitle	Stand-alone Bluetooth 5 low energy and IEEE 802.15.4 module	
Document type	Data sheet	
Document number	UBX-19039467	
Revision and date	R07	22-Jun-2022
Disclosure restriction	C1-Public	

Product status	Corresponding content status	
Functional sample	Draft	For functional testing. Revised and supplementary data will be published later.
In development / Prototype	Objective specification	Target values. Revised and supplementary data will be published later.
Engineering sample	Advance information	Data based on early testing. Revised and supplementary data will be published later.
Initial production	Early production information	Data from product verification. Revised and supplementary data may be published later.
Mass production / End of life	Production information	Document contains the final product specification.

This document applies to the following products:

Product name	Type number	Firmware version	PCN reference	Product status
BMD-380	BMD-380-A-R-10	N/A	N/A	Initial production

u-blox or third parties may hold intellectual property rights in the products, names, logos and designs included in this document. Copying, reproduction, modification or disclosure to third parties of this document or any part thereof is only permitted with the express written permission of u-blox.

The information contained herein is provided "as is" and u-blox assumes no liability for its use. No warranty, either express or implied, is given, including but not limited to, with respect to the accuracy, correctness, reliability and fitness for a particular purpose of the information. This document may be revised by u-blox at any time without notice. For the most recent documents, visit www.u-blox.com.

Copyright © u-blox AG.

Contents

Document information	2
Contents	3
1 Functional description	5
1.1 Features.....	5
1.2 Applications.....	6
1.3 Block diagram.....	6
1.4 Product specifications.....	7
2 Pin definition	9
2.1 Pin assignment.....	9
2.2 Peripheral pins.....	11
3 Electrical specifications	12
3.1 Absolute maximum ratings.....	12
3.2 Operating conditions.....	12
3.3 Power and DCDC configuration.....	13
3.3.1 USB power.....	13
3.3.2 Normal (LV) power mode examples.....	14
3.3.3 High voltage (HV) power mode examples.....	15
3.4 General purpose I/O.....	15
3.5 Module reset.....	16
3.6 Debug and programming.....	16
3.7 Clocks.....	16
3.7.1 32.768 kHz crystal (LFXO).....	17
3.7.2 32.768 kHz clock source comparison.....	17
4 Firmware	18
4.1 Factory image.....	18
4.2 SoftDevices.....	18
4.2.1 S140.....	18
4.2.2 S340.....	18
4.3 IEEE 802.15.4 (Thread and Zigbee).....	19
4.4 Bluetooth device address.....	19
5 Mechanical specifications	20
5.1 Dimensions.....	20
5.2 Recommended PCB land pads.....	20
5.3 Module and label marking.....	21
6 RF design notes	22
6.1 Recommended RF layout and ground plane.....	22
6.2 Mechanical enclosure.....	22
6.3 Antenna patterns.....	23
6.3.1 X-Y plane.....	23
6.3.2 X-Z plane.....	24

6.3.3 Y-Z plane.....	24
7 BMD-380 evaluation development kit.....	25
8 Qualification and approvals.....	26
8.1 United States (FCC)	26
8.1.1 Labeling and user information requirements	26
8.1.2 RF exposure	26
8.2 Canada (ISED).....	27
8.2.1 Labeling and user information requirements	27
8.2.2 RF exposure	27
8.3 European Union regulatory compliance	27
8.3.1 Radio Equipment Directive (RED) 2014/53/EU	28
8.4 Australia / New Zealand (RCM)	28
8.5 Bluetooth qualification.....	28
9 Environmental.....	29
9.1 RoHS	29
9.2 REACH.....	29
9.3 California proposition 65 (P65)	29
10 Product handling.....	30
10.1 Packaging	30
10.1.1 Reel packaging	30
10.1.2 Carrier tape dimensions	30
10.2 Carrier tape orientation	30
10.3 Moisture sensitivity level.....	31
10.4 Reflow soldering	31
10.5 ESD precautions.....	31
11 Ordering information.....	32
12 Life support and other high-risk warnings.....	33
Related documents	34
Revision history	34
Contact.....	34

1 Functional description

The BMD-380 is a small form factor, advanced, highly flexible, ultra-low power multiprotocol System on Module (SoM) that enables Bluetooth 5 low energy and IEEE 802.15.4 (Thread and Zigbee) connectivity for portable, extremely low power embedded systems. With an Arm® Cortex®-M4 with FPU processor, integrated 2.4 GHz transceiver, and an integrated antenna, the BMD-380 provides a complete RF solution allowing faster time to market with reduced development costs. Providing full use of the Nordic Semiconductor nRF52840's capabilities and peripherals, the BMD-380 can power the most demanding applications, all while simplifying designs and reducing BOM costs. The BMD-380 is an ideal solution for designs that require Bluetooth 5 features or 802.15.4 based networking for Thread and Zigbee. Increased integration with built in USB and 5.5 V compatible DC/DC supply reduces design complexity and BOM cost, while expanding possible applications.

1.1 Features

- Based on the Nordic Semiconductor nRF52840 SoC
- Bluetooth 5 PHYs: LE 1M, LE 2M, and LE Coded (long range)
- Bluetooth 5 features: Advertising Extensions, Channel Selection Algorithm #2
- Bluetooth Mesh
- IEEE 802.15.4 with Thread and Zigbee support
- Complete RF solution with integrated chip antenna
- Integrated DC-DC converters
- No external components required
- Arm® Cortex®-M4 with FPU 32-bit processor
- ARM® TrustZone® Cryptocell 310 security
- True Random Number Generator
- Serial Wire Debug (SWD)
- Nordic Semiconductor SoftDevice ready
- 1MB embedded flash memory
- 256 kB RAM
- 44 General Purpose I/O Pins
- 12-bit/200KSPS ADC
- One Full-Speed USB (12 Mbps)
- Four SPI Master/Slave (8 Mbps)
- Quad SPI with Execute in Place (XIP)
- PWM 4 blocks x 4-channels each
- General Purpose and Low power comparators
- Temperature sensor
- Two 2-wire Master/Slave (I2C compatible)
- I2S audio interface
- Two UARTs (w/ CTS/RTS and DMA)
- 20-channel CPU independent Programmable Peripheral Interconnect (PPI)
- Quadrature Demodulator (QDEC)
- 5 x 32 bit timer/counters
- 3 x 24 bit Real Timer Counters (RTC)
- NFC-A tag interface for OOB pairing
- Dimensions: 9.5 x 7.5 x 1.5 mm

1.2 Applications

- Climate Control
- Lighting products
- Safety and Security
- Home Appliances
- Access Control
- Internet of Things
- Home Health Care
- Advanced Remote Controls
- Smart Energy Management
- Low-Power Sensor Networks
- Interactive Entertainment Devices
- Environmental Monitoring
- Hotel Automation
- Office Automation

1.3 Block diagram

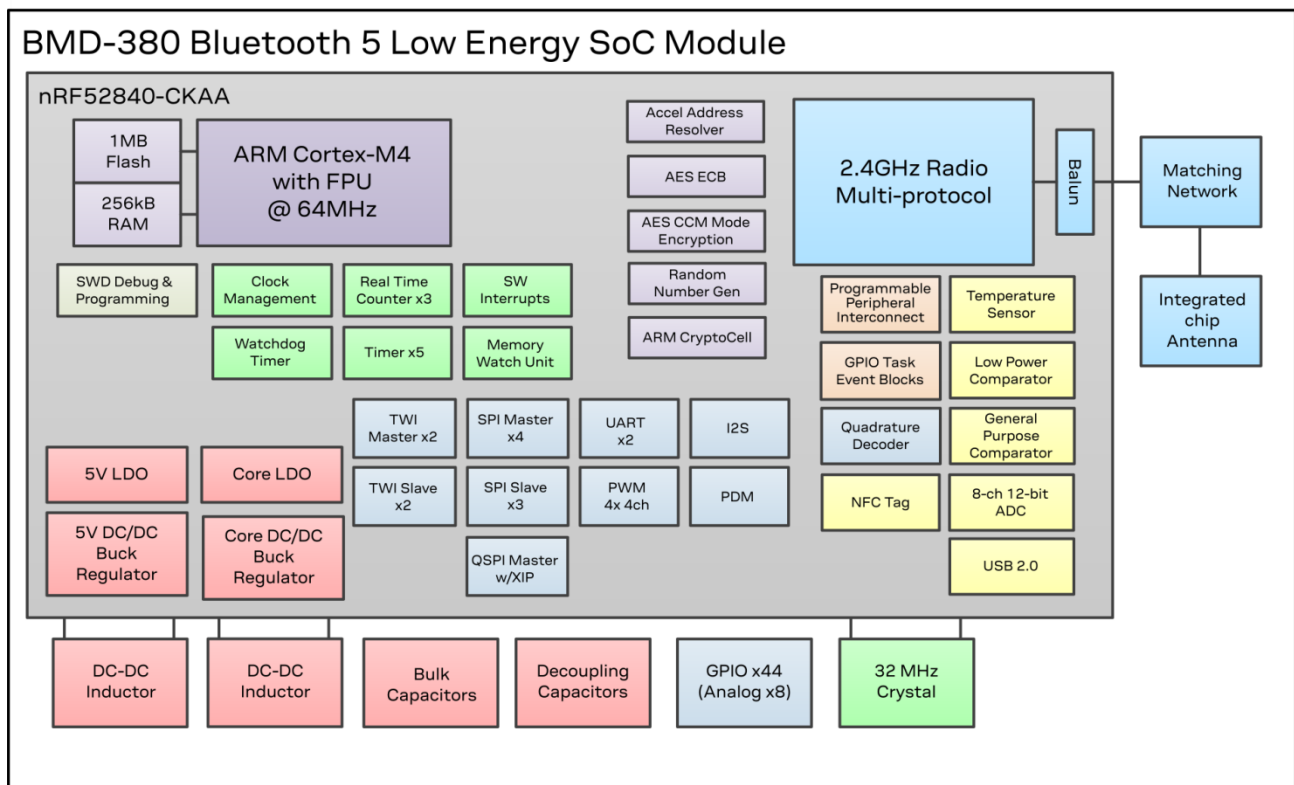

Figure 1: Block diagram of BMD-380

1.4 Product specifications

Detail	Description
Bluetooth	
Bluetooth version	Bluetooth v5.1 Low Energy, Concurrent Central & Peripheral (S140), LE Coded PHY (Long Range), LE 2M PHY, LE 1M PHY, Advertising Extensions, CSA #2, Bluetooth mesh
Security	AES-128, Arm® Cryptocell accelerated
LE connections	Concurrent central, observer, peripheral, and broadcaster roles with up to twenty concurrent connections along with one Observer and one Broadcaster (S140)
IEEE 802.15.4	
Thread stack	OpenThread, Thread 1.1
Thread security	AES-128, Arm® Cryptocell accelerated
Zigbee stack	Zigbee Compliant Platform
Radio	
Frequency	2.360 GHz to 2.500 GHz
Modulations	GFSK at 1 Mbps and 2 Mbps, QPSK at 250 Kbps
Transmit power	+8 dBm maximum
Receiver sensitivity	-96 dBm (Bluetooth low energy mode)
Antenna	Integrated chip (-1 dBi max gain)
Current consumption	
TX only @ +8 dBm, 0 dBm @ 3V, DCDC enabled	14.8 mA, 4.8 mA
TX only @ +8 dBm, 0 dBm	32.7 mA, 10.6 mA
RX only @ 1 Mbps @ 3V, DCDC enabled	4.6 mA
RX only @ 1 Mbps	9.9 mA
CPU @ 64 MHz from flash, from RAM	6.3 mA, 5.2 mA
CPU @ 64 MHz from flash, from RAM @ 3 V, DCDC enabled	3.3 mA, 2.8 mA
System Off, On (Supply on VDD), no RAM retention	0.4 μA, 0.97 μA
System Off, On (Supply on VDD), full 256 KB RAM retention	1.86 μA, 2.35 μA
Dimensions	
BMD-380	Length: 9.5 mm ± 0.3 mm
	Width: 7.5 mm ± 0.3 mm
	Height: 1.5 mm ± 0.1 mm
Hardware	
Interfaces	SPI Master/Slave x 4 Quad SPI x 1 UART x 2 Two-Wire Master/Slave (I2C) x 2 GPIO x 44 I2S x 1 PWM x 16 (4 blocks x 4-channels each) PDM x 1 USB 2.0 x 1 Analog input x 8
Power supply	VDD: 1.7 V to 3.6 V, 1.75 V required to start DCDC VDDH: 2.5 V to 5.5 V VBUS: 4.35 V to 5.5 V (For USB operation)

Detail	Description
Temperature range	-40 °C to +85 °C
Certifications	
USA (FCC)	FCC part 15.247 modular certification FCC ID: XPYBMD380
Canada (ISED)	Innovation, Science and Economic Development Canada RSS-247 modular certification IC: 8595A-BMD380
Europe (CE)	3.1 (a): Health and Safety of the User <ul style="list-style-type: none"> • EN 62368-1:2014+A11:2017 • EN 62479:2010 3.1 (b): Electromagnetic Compatibility <ul style="list-style-type: none"> • EN 301 489-1 V2.2.3 • EN 301 489-17 V3.2.2 3.2: Effective use of spectrum allocated <ul style="list-style-type: none"> • EN 300 328 V2.2.2
Australia / New Zealand (RCM)	AS/NZS 4268:2017, Radio equipment and systems – Short range devices
Bluetooth	v5.1 BMD-380 End Product – DID: D050595; QDID: 138767
Radio chip	
Nordic Semiconductor nRF52840	Additional details: nRF52840 Product Specification Software Development Kit

Table 1: Radio performance

2 Pin definition

2.1 Pin assignment

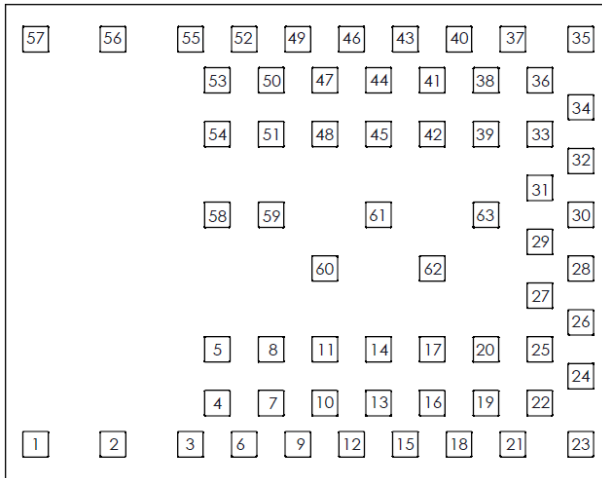

Figure 2: BMD-380 pin assignment (Top view)

Pin	Name	Direction	Description	nRF52 pin	Remarks
1	GND	Power	Electrical Ground		
2	GND	Power	Electrical Ground		
3	GND	Power	Electrical Ground		
4	SWCLK	In	SWD Clock	SWCLK	
5	GND	Power	Electrical Ground		
6	P0.22	In/Out	GPIO	P0.22	
7	SWDIO	In/Out	SWD IO	SWDIO	
8	P0.25	In/Out	GPIO	P0.25	
9	P0.19	In/Out	GPIO	P0.19	
10	P0.21	In/Out	GPIO	P0.21	
11	P1.00	In/Out	GPIO/TRACEDATA[0]/SWO	P1.00	
12	P0.18	In/Out	GPIO/RESET	P0.18	
13	P0.17	In/Out	GPIO	P0.17	
14	P0.20	In/Out	GPIO	P0.20	
15	VBUS	Power	USB PHY supply: 4.35 V to 5.5 V in Connect to USB Host device 5 V supply	VBUS	
16	P0.14	In/Out	GPIO	P0.14	
17	P0.13	In/Out	GPIO	P0.13	
18	P0.11	In/Out	GPIO/TRACEDATA[2]	P0.11	
19	USB-D-	In/Out	USB Data -	USB-D-	
20	P0.15	In/Out	GPIO	P0.15	
21	USB-D+	In/Out	USB Data +	USB-D+	
22	VCCH	Power	LV Mode: Connect to VCC HV Mode: 2.5 V to 5.5 V in	VDDH	The module has an internal 4.7 μ F bulk capacitor. However, it is good design practice to add additional bulk capacitance as required for your application, i.e., for heavy GPIO usage and/or current draw.
23	GND	Power	Electrical Ground		

Pin Name	Direction	Description	nRF52 pin	Remarks	
24	VCC	Power In/Out	VDD	The module has an internal 4.7 μ F bulk capacitor. However, it is good design practice to add additional bulk capacitance as required for your application, i.e., for heavy GPIO usage and/or current draw.	
25	P1.08	In/Out	GPIO	P1.08	Standard drive, low frequency I/O only (<10 kHz)
26	P0.12	In/Out	GPIO/TRACEDATA[1]	P0.12	
27	P0.07	In/Out	GPIO/TRACECLK	P0.07	
28	P1.09	In/Out	GPIO/TRACEDATA[3]	P1.09	
29	P0.08	In/Out	GPIO	P0.08	
30	P0.06	In/Out	GPIO	P0.06	
31	P0.05	In/Out	GPIO/AIN3	P0.05	
32	P0.27	In/Out	GPIO	P0.27	
33	P0.26	In/Out	GPIO	P0.26	
34	P0.04	In/Out	GPIO/AIN2	P0.04	
35	GND	Power	Electrical Ground		
36	P0.01	In/Out	GPIO/XTAL2 (32.768kHz)	P0.01	
37	P0.29	In/Out	GPIO/AIN5	P0.29	Standard drive, low frequency I/O only (<10 kHz)
38	P0.00	In/Out	GPIO/XTAL1 (32.768kHz)	P0.00	
39	P0.31	In/Out	GPIO/AIN7	P0.31	Standard drive, low frequency I/O only (<10 kHz)
40	P1.15	In/Out	GPIO	P1.15	Standard drive, low frequency I/O only (<10 kHz)
41	P0.02	In/Out	GPIO/AIN0	P0.02	Standard drive, low frequency I/O only (<10 kHz)
42	P0.30	In/Out	GPIO/AIN6	P0.30	Standard drive, low frequency I/O only (<10 kHz)
43	P0.28	In/Out	GPIO/AIN4	P0.28	Standard drive, low frequency I/O only (<10 kHz)
44	P1.12	In/Out	GPIO	P1.12	Standard drive, low frequency I/O only (<10 kHz)
45	P1.14	In/Out	GPIO	P1.14	Standard drive, low frequency I/O only (<10 kHz)
46	P0.03	In/Out	GPIO/AIN1	P0.03	Standard drive, low frequency I/O only (<10 kHz)
47	P1.13	In/Out	GPIO	P1.13	Standard drive, low frequency I/O only (<10 kHz)
48	P1.03	In/Out	GPIO	P1.03	Standard drive, low frequency I/O only (<10 kHz)
49	P1.10	In/Out	GPIO	P1.10	Standard drive, low frequency I/O only (<10 kHz)
50	P1.06	In/Out	GPIO	P1.06	Standard drive, low frequency I/O only (<10 kHz)
51	P1.11	In/Out	GPIO	P1.11	Standard drive, low frequency I/O only (<10 kHz)
52	P0.10	In/Out	GPIO/NFC2	P0.10	Standard drive, low frequency I/O only (<10 kHz)
53	P0.09	In/Out	GPIO/NFC1	P0.09	Standard drive, low frequency I/O only (<10 kHz)
54	GND	Power	Electrical Ground		
55	GND	Power	Electrical Ground		
56	GND	Power	Electrical Ground		
57	GND	Power	Electrical Ground		
58	GND	Power	Electrical Ground		
59	P1.02	In/Out	GPIO	P1.02	Standard drive, low frequency I/O only (<10 kHz)
60	P0.24	In/Out	GPIO	P0.24	
61	P0.23	In/Out	GPIO	P0.23	
62	P0.16	In/Out	GPIO	P0.16	
63	GND	Power	Electrical Ground		

Table 2: BMD-380 pin-out

¹ In HV mode, VCC acts as a regulated supply that can power other external devices. The voltage output of VCC can be configured in software but is limited to no more than VCCH-0.3 V. In System Off mode, VCC can supply no more than 1 mA.

2.2 Peripheral pins

The BMD-380 features a pin multiplexing system that allows most internal peripherals, such as UART and SPI, to be used on any GPIO pin. This freedom in pin choice enables better optimization of designs and PCB layout.

 Only one peripheral signal can be multiplexed to a GPIO pin at a time. Some functions are restricted to certain pins due to additional internal circuitry required by the interface. These include Trace signals, analog inputs, XTAL signals, USB signals, SWD interface, and reset. See [Table 3](#).

Peripheral	Signal	Pin Options
UART0, UART1, I2C0, I2C1, SPI0, SPI1, SPI2, SPI3, I2S0, QSPI0, PDM0, PWM0, PWM1, PWM2, PWM3	All	P0.00-P0.31, P1.00-P1.15
ADC, COMP, LPCOMP	All	P0.02-P0.05, P0.28-P0.31 (AIN0-AIN7)
NFC	NFC1	P0.09
	NFC2	P0.10
Reset	RESET	P0.18
Trace	TRACECLK	P0.07
	SWO/TRACEDATA[0]	P1.00
	TRACEDATA[1]	P0.12
	TRACEDATA[2]	P0.11
	TRACEDATA[3]	P1.09
SWD	SWD Clock	SWCLK
	SWD IO	SWDIO
32.768 kHz Crystal	XTAL1	P0.00
	XTAL2	P0.01
USB	USB Data +	USB-D+
	USB Data -	USB-D-

Table 3 – Peripheral pin options

 Some peripherals on the BMD-380 share the same memory location for their registers. This means that only one of these peripherals can be used at a time. It is possible to switch between peripherals that share the same register location by clearing and reinitializing the associated configuration registers. See Nordic Semiconductor nRF52840 Product Specification for details.

Peripheral ID	Base address	Shared peripherals	
3	0x40003000	SPI0	I2C0
4	0x40004000	SPI1	I2C1

Table 4 – Peripherals with shared registers

3 Electrical specifications

Stressing the device above one or more of the [Absolute maximum ratings](#) can cause permanent damage. These are stress ratings only. Operating the module at these or at any conditions other than those specified in the [Operating conditions](#) should be avoided. Exposure to absolute maximum rating conditions for extended periods may affect device reliability.

All given application information is only advisory and does not form part of the specification.

3.1 Absolute maximum ratings

Symbol	Description	Min	Max	Unit
V _{CC_MAX}	Voltage on supply pin	-0.3	3.9	V
V _{CCH_MAX}	Voltage on VCCH supply pin	-0.3	5.8	V
V _{BUS_MAX}	Voltage on VBUS Supply pin	-0.3	5.8	V
V _{IO_MAX}	Voltage on GPIO pins (VCC > 3.6 V)	-0.3	3.9	V
V _{IO_MAX}	Voltage on GPIO pins (VCC ≤ 3.6 V)	-0.3	VCC + 0.3 V	V
T _S	Storage Temperature Range	-40	125	°C

Table 5: Absolute maximum ratings

The product is not protected against overvoltage or reversed voltages. If necessary, voltage spikes exceeding the power supply voltage specification, given in [Table 5](#), must be limited to values within the specified boundaries by using appropriate protection devices.

3.2 Operating conditions

Unless otherwise specified, all operating condition specifications are at an ambient temperature of 25 °C and a supply voltage of 3.3 V.

Operation beyond the specified operating conditions is not recommended and extended exposure beyond them may affect device reliability.

Symbol	Parameter	Min	Typ.	Max	Unit
V _{CC_IN}	VCC operating supply voltage in	1.7	3.0	3.6	V
V _{CC_START}	VCC DCDC starting voltage	1.75	-	-	V
V _{CCH_HV}	VCCH operating supply voltage in	2.5	5.0	5.5	V
V _{BUS_IN}	VBUS operating supply voltage in	4.35	5.0	5.5	V
T _{R_VCC}	VCC Supply rise time (0 V to 1.7 V)	-	-	60	ms
T _{R_VCCH}	VCCH Supply rise time (0 V to 3.7 V) ²	-	-	100	ms
T _A	Operating Ambient Temperature Range	-40	25	85	°C

Table 6: Operating conditions

² Applies when the module is configured to use HV mode. When using LV mode T_{R_VCC} applies.

3.3 Power and DCDC configuration

 The BMD-380 is based on the nRF52840, revision 2 or newer IC.

The BMD-380 has two internal regulator stages that each contain an LDO and DCDC regulator. The first regulator, REG0, is fed by the **VCCH** pin and can accept a source voltage of 2.5 V to 5.5 V. The output of REG0 is connected to the **VCC** pin and the input of the second regulator stage REG1. REG1 supplies power to the module core and can accept an input source voltage of 1.7 V to 3.6 V. Depending on how the **VCC** and **VCCH** pins are connected, the module will operate in one of two modes: Normal/Low Voltage (LV) or High Voltage (HV). The voltage present on the VCC pin is always the GPIO high logic level voltage, regardless of power mode.

To enter LV Mode, the same source voltage is applied to both the **VCC** and **VCCH** pins causing REG0 to automatically shut down leaving only the REG1 stage active. To enter HV, the source voltage is only applied to **VCCH** causing the **VCC** pin to become an output source supplied by REG0.

Mode	Pin	Name	Connection
Normal (LV)	24	VCC	1.7V to 3.6V source in
	22	VCCH	Same source as VCC
High Voltage (HV)	24	VCC	1.8V to 3.3V supply out
	22	VCCH	2.5V to 5.5V source in

Table 7: Power mode pin connections

 **Important:** In both LV and HV modes, the GPIO logic level voltage is determined by the **VCC** pin. In HV mode, all external devices that are connected to the BMD-380's GPIO must either be powered by the module (from **VCC**) or use level translation.

REG0 can supply a maximum current of 25 mA for the module and external circuits in System On Mode and 1 mA in System Off Mode. External circuits powered from VCC in HV mode should be limited to no more than 5 mA to ensure stability at all radio transmit power levels.

3.3.1 USB power

The USB interface on the BMD-380 can be used when the module is in either Normal (LV) or High Voltage (HV) mode. The BMD-380 USB PHY is powered by a dedicated, internal LDO regulator that is fed by the VBUS pin (66). This means that applying power to only the VBUS pin will not power the rest of the module. In order for the USB PHY to operate, VBUS must be externally powered.

3.3.2 Normal (LV) power mode examples

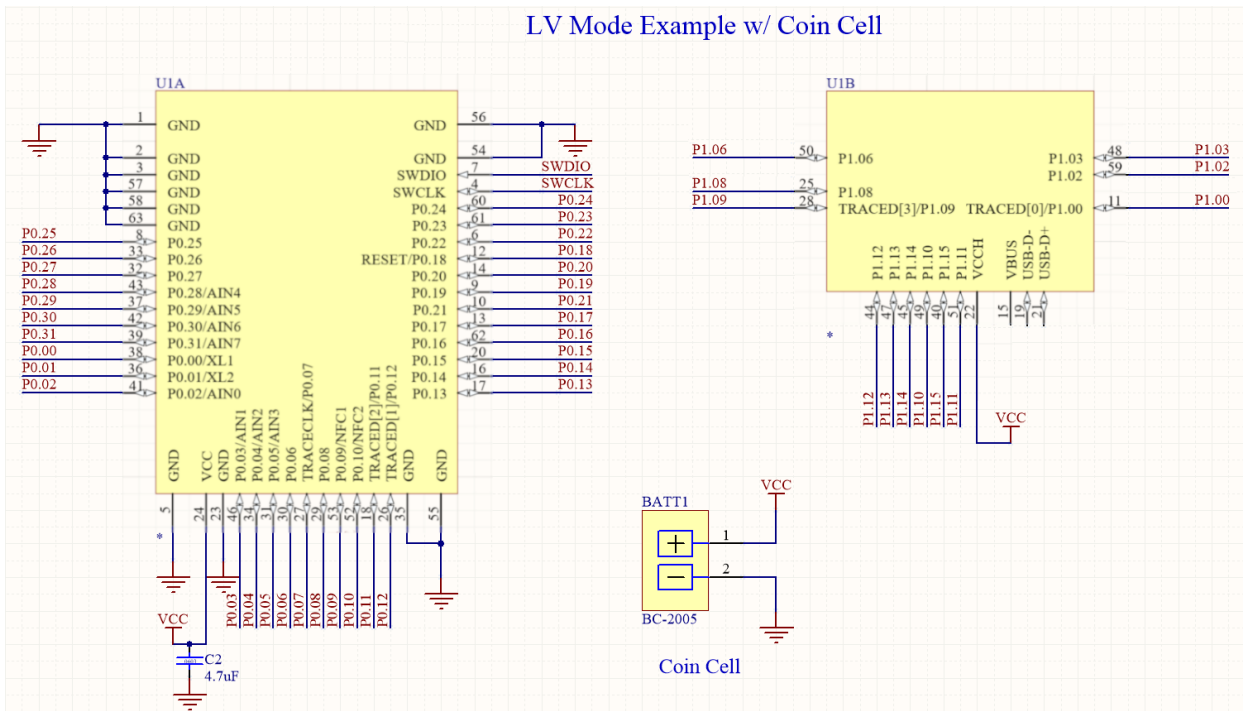

Figure 3: LV mode w/ coin cell example

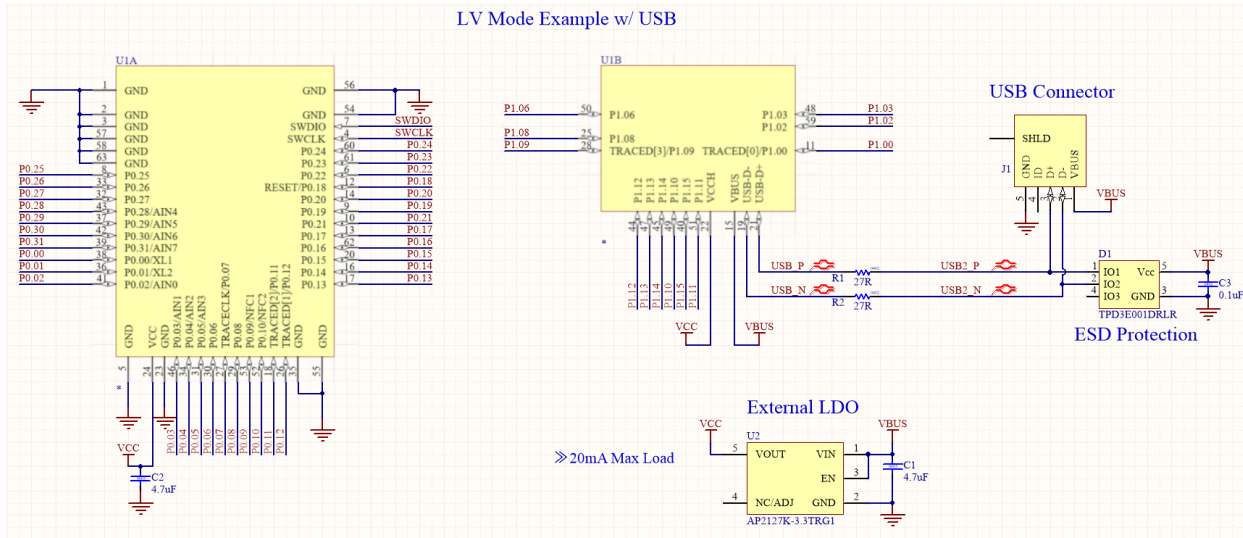

Figure 4: LV mode example w/ USB and external regulator

3.3.3 High voltage (HV) power mode examples

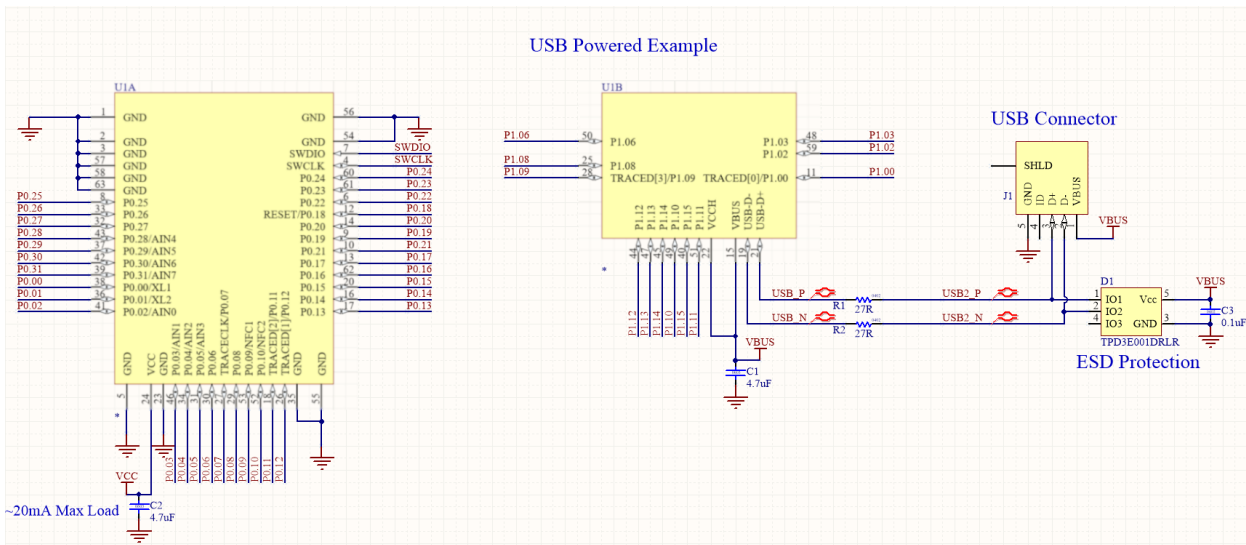

Figure 5: USB-Powered HV mode example

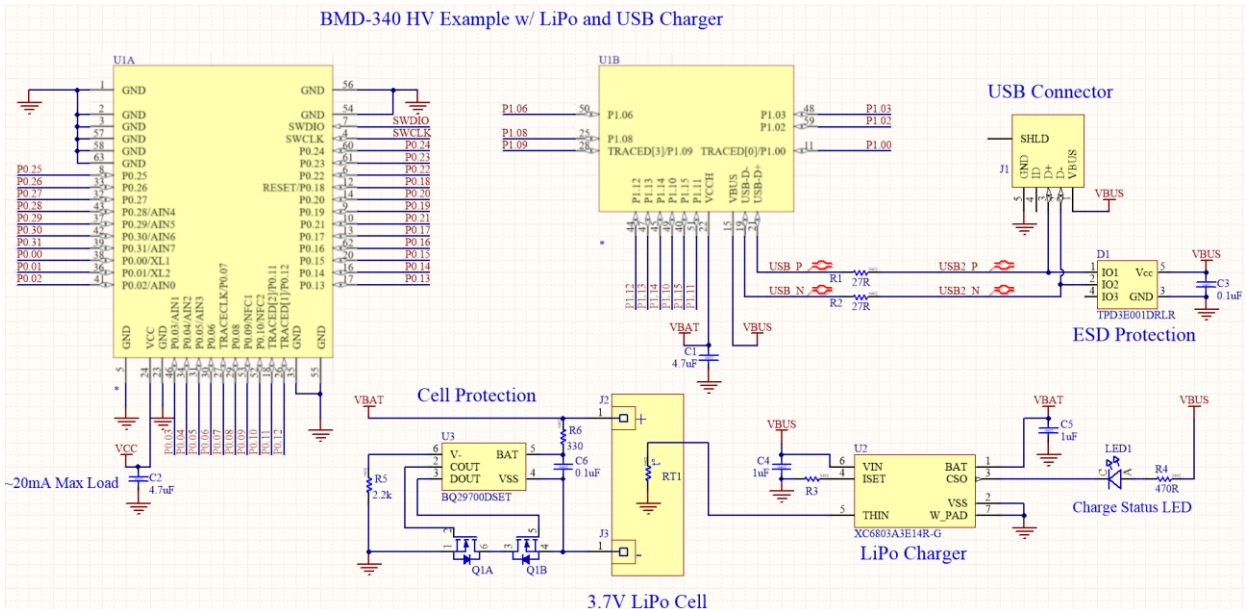

Figure 6: LiPo Powered HV example w/ USB charger

⚠ Important: The LiPo circuit above is meant to be a generic example of how the BMD-380's power modes can be used. Great care must be taken when integrating Lithium-Ion batteries into a design. Protection circuits suitable for the type of battery used and the application must always be implemented.

3.4 General purpose I/O

The general purpose I/O is organized as two ports enabling access and control of 44 available GPIO pins. The first port allows access of P0.00 to P0.31, similar to the one port available on the BMD-350. The second port allows access to P1.00 to P1.15 (excluding P1.01, P1.04, P1.05, P1.07). Each GPIO can be accessed individually with the following user configurable features:

- Input/output direction
- Output drive strength

- Internal pull-up and pull-down resistors
- Wake-up from high- or low-level triggers on all pins
- Trigger interrupt on all pins
- All pins can be used by the PPI task/event system; the maximum number of pins that can be interfaced through the PPI simultaneously is limited by the number of GPIOTE channels
- All pins can be individually configured to carry serial interface or quadrature demodulator signals
- Pins P1.01, P1.04, P1.05, and P1.07 are not available on the BMD-380

Symbol	Parameter	Min.	Typ.	Max.	Unit
V _{IH}	Input High Voltage	0.7 x VCC	-	VCC	V
V _{IL}	Input Low Voltage	VSS	-	0.3 x VCC	V
V _{OH}	Output High Voltage	VCC - 0.4	-	VCC	V
V _{OL}	Output Low Voltage	VSS	-	VSS + 0.4	V
R _{PU}	Pull-up Resistance	11	13	16	kΩ
R _{PD}	Pull-down Resistance	11	13	16	kΩ

Table 8: GPIO electrical specifications

3.5 Module reset

GPIO pin P0.18 may be used for a hardware reset. In order to utilize P0.18 as a hardware reset, the UICR registers PSELRESET[0] and PSELRESET[1] must be set alike, to the value of 0x7FFFFFFD2. When P0.18 is programmed as RESET, the internal pull-up is automatically enabled. Nordic Semiconductor example applications and development kits program P0.18 as RESET_N.

3.6 Debug and programming

The BMD-380 series supports the two pin Serial Wire Debug (SWD) interface and offers flexible and powerful mechanism for non-intrusive debugging of program code. Breakpoints, single stepping, and instruction trace capture of code execution flow are part of this support.

The BMD-380 also supports ETM and ITM trace. The trace data from the ETM and the ITM is sent to an external debugger via a 4-bit wide parallel trace port. In addition to parallel trace, the TPIU supports serial trace via the Serial Wire Output (SWO) trace protocol.

3.7 Clocks

The BMD-380 requires two clocks, a high frequency clock and a low frequency clock.

The high frequency clock is provided on-module by a high-accuracy 32 MHz crystal as required by the nRF528340 for radio operation.

The low frequency clock can be provided internally by an RC oscillator or synthesized from the fast clock, or externally by a 32.768 kHz crystal. An external crystal provides the lowest power consumption and greatest accuracy. Using the internal RC oscillator with calibration provides acceptable performance for Bluetooth low energy applications at a reduced cost and slight increase in power consumption.

3.7.1 32.768 kHz crystal (LFXO)

Symbol	Parameter	Typ.	Max.	Unit
F_{NOM_LFXO}	Crystal frequency	32.768	-	kHz
$F_{TOL_LFXO_BLE}$	Frequency tolerance, Bluetooth low energy applications ³	-	±500	ppm
$f_{TOL_LFXO_ANT}$	Frequency Tolerance, ANT applications ⁴	-	±50	ppm
C_{L_LFXO}	Load Capacitance	-	12.5	pF
C_{0_LFXO}	Shunt Capacitance	-	2	pF
R_{S_LFXO}	Equivalent series resistance	-	100	kΩ
C_{pin}	Input Capacitance on XL1 & XL2 pads	4	-	pF

Table 9: 32.768 kHz crystal (LFXO)

3.7.2 32.768 kHz clock source comparison

Symbol	Parameter	Min.	Typ.	Max.	Unit
I_{LFXO}	Current for 32.768 kHz Crystal Oscillator	-	0.23	-	μA
I_{LFRC}	Current for 32.768 kHz RC Oscillator	-	0.7	1	μA
I_{LFSYNT}	Current for 32.768 kHz Synthesized Oscillator	-	100	-	μA
$f_{TOL_LFXO_BLE}$	Frequency Tolerance, 32.768 kHz Crystal Oscillator (Bluetooth low energy Stack) ³	-	-	±500	ppm
$f_{TOL_LFXO_ANT}$	Frequency Tolerance, 32.768 kHz Crystal Oscillator (ANT Stack) ⁴	-	-	±50	ppm
f_{TOL_LFRC}	Frequency Tolerance, 32.768 kHz RC Oscillator	-	-	±5	%
$f_{TOL_CAL_LFRC}$	Frequency tolerance, 32.768 kHz RC after calibration	-	-	±500	ppm
f_{TOL_LFSYNT}	Frequency Tolerance, 32.768 kHz Synthesized Oscillator	-	-	±48	ppm

Table 10: 32.768 kHz clock source comparison

³ $f_{TOL_LFXO_BLE}$ and $f_{TOL_LFXO_ANT}$ are the maximum allowed for Bluetooth low energy and ANT applications. Actual tolerance depends on the crystal used.

⁴ The ANT protocol requires the use of an external crystal.

4 Firmware

Projects for the BMD-380 should utilize the [Nordic Semiconductor SDK](#) and the nRF52840 tools for new development. This will allow access to the very latest Bluetooth support from Nordic Semiconductor and provide an ongoing path as new features are released.

4.1 Factory image

The BMD-380 module is not loaded with a factory firmware image. The unique, public IEEE Bluetooth device address is printed on the module label and is also programmed into the UICR.

4.2 SoftDevices

Nordic Semiconductor protocol stacks for Bluetooth and ANT are known as SoftDevices. SoftDevices are pre-compiled, pre-linked binary files. SoftDevices can be programmed in nRF52 series SoCs and are downloadable from the Nordic Semiconductor website. The BMD-380 with the nRF52840 SoC supports the S140 (Bluetooth low energy Peripheral) and S340 (ANT & Bluetooth low energy) SoftDevices.

4.2.1 S140

The SoftDevice S140 is a feature complete Bluetooth 5 qualified protocol stack for the nRF52840 SoC. It supports up to 20 concurrent links in all roles. It supports Bluetooth 5 features: 2 Mbps, Long Range, Advertising Extensions and channel selection algorithm #2(CSA #2). The number of connections and bandwidth per connection are configurable, offering memory and performance optimization.

It is a complete stack with GAP, GATT, ATT, SM, L2CAP, and Link Layer. Both GATT Server and Client are supported. The broad feature set also includes Privacy 1.2, LE Data Length Extension (DLE), configurable ATT MTU, L2CAP connection-oriented channels and LE Secure Connections.

SoftDevice S140 is available for download [here](#).

4.2.2 S340

SoftDevice S340 is a combined Bluetooth 5 and ANT™ protocol stack for the nRF52840 SoC, supporting concurrent operation of the two.

It is a Bluetooth 5 qualified protocol stack that offers up to 20 concurrent links in all roles. It supports all Bluetooth 5 features: 2 Mbps, Long Range, Advertising Extensions and channel selection algorithm #2 (CSA #2). The number of connections and bandwidth per connection is configurable, offering memory and performance optimization.

It is a complete Bluetooth LE stack with GAP, GATT, ATT, SM, L2CAP, and Link Layer. Both GATT Server and Client are supported. The broad feature set also includes Privacy 1.2, LE Data Length Extension (DLE), configurable ATT MTU, L2CAP connection-oriented channels and LE Secure Connections.

It supports all ANT features and offers a variety of network topologies, including peer-to-peer, star and tree. Up to 15 individual channels are available, with broadcast, acknowledged, or burst transfer communication.

SoftDevice S340 is available for download [here](#).

4.3 IEEE 802.15.4 (Thread and Zigbee)

IEEE 802.15.4 based protocols, such as Thread and Zigbee, on the BMD-380 are not implemented using a SoftDevice. Nordic Semiconductor provides an IEEE 802.15.4 compliant MAC stack which does not require a SoftDevice to be loaded to operate. Nordic Semiconductor also provides pre-compiled Thread and Zigbee stacks. See the [Nordic Semiconductor SDK](#) for more information on developing applications that utilize IEEE 802.15.4. Both allow for concurrent operation with BLE SoftDevices.

4.4 Bluetooth device address

The BMD-380 module is preprogrammed from the factory with a unique public Bluetooth device (MAC) address stored in the CUSTOMER[0] and CUSTOMER[1] registers of the User Information Configuration Registers (UICR). The Bluetooth device address consists of the IEEE Organizationally Unique Identifier (OUI) combined with the six hexadecimal digits that are printed in human-readable text on the module label. The full Bluetooth device address is also available in the 2D barcode on the module label. See also [Module and label marking](#). The Bluetooth device address is stored in little endian format. The most significant bytes of the CUSTOMER[1] register are 0xFF to complete the 32-bit register.

UICR Register	Address	Description	Remarks
CUSTOMER[0]	0x10001080	Bluetooth_addr [0] (0xFF)	Printed on module label in 2D barcode and human readable text.
CUSTOMER[0]	0x10001081	Bluetooth_addr [1] (0xEE)	Printed on module label in 2D barcode and human readable text.
CUSTOMER[0]	0x10001082	Bluetooth_addr [2] (0xDD)	Printed on module label in 2D barcode and human readable text.
CUSTOMER[0]	0x10001083	Bluetooth_addr [3] (0xCC)	IEEE OUI. Printed on module label in 2D barcode.
CUSTOMER[1]	0x10001084	Bluetooth_addr [4] (0xBB)	IEEE OUI. Printed on module label in 2D barcode.
CUSTOMER[1]	0x10001085	Bluetooth_addr [5] (0xAA)	IEEE OUI. Printed on module label in 2D barcode.
CUSTOMER[1]	0x10001086	0xFF	Unused
CUSTOMER[1]	0x10001087	0xFF	Unused

Table 11: Bluetooth device address

5.3 Module and label marking

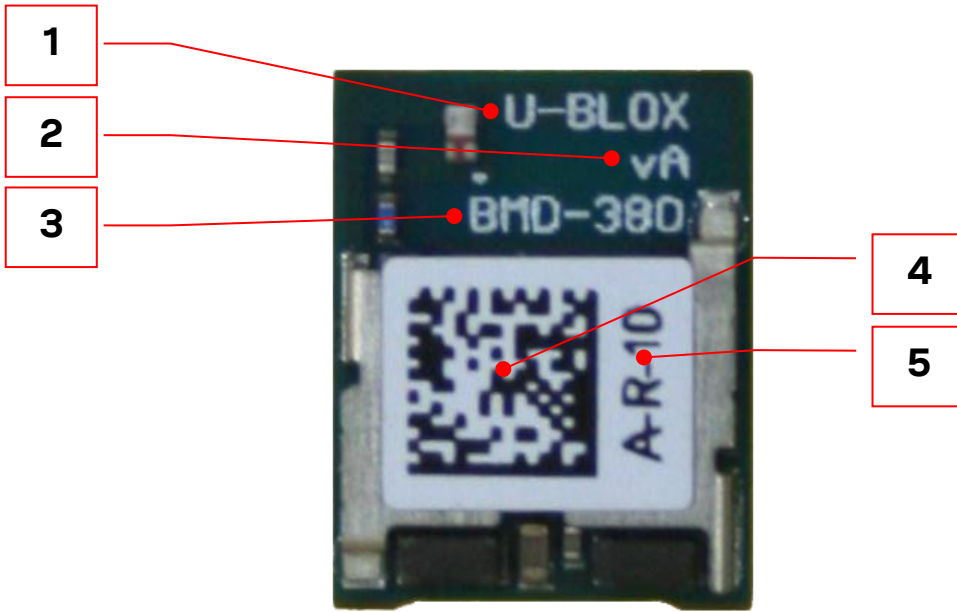

Figure 9: Module marking for type number BMD-380-A-R-10

Reference	Description
1	“U-BLOX” imprinted on silkscreen
2	PCB revision
3	Product name (Model)
4	Data Matrix with unique serial number of 19 alphanumeric symbols. The first 3 symbols represent module type number unique to each module variant, the next 12 symbols represent the unique hexadecimal Bluetooth device address of the module AABBCCDDEEFF, and the last 4 symbols represent the hardware and firmware version encoded HHFF.
3+5	Product type number



Table 12: Module and label marking for type number BMD-380-A-R-10

6 RF design notes

6.1 Recommended RF layout and ground plane

The integrated antenna requires a suitable ground plane to radiate effectively.

The area under and extending out from the antenna portion of the module should be kept clear of copper and other metal. The module should be placed at the edge of the PCB with the antenna edge facing out. Reducing the ground plane from that shown in [Figure 10](#) will reduce the effective radiated power.

-  Align the module keep-out with edge of host PCB copper pour (top of 2.90 mm dimension below).
-  For best performance, center the module on the longest edge of the host PCB.
-  If a different size board is used, place the sides of the module at least 10 mm from the corresponding PCB board edge.

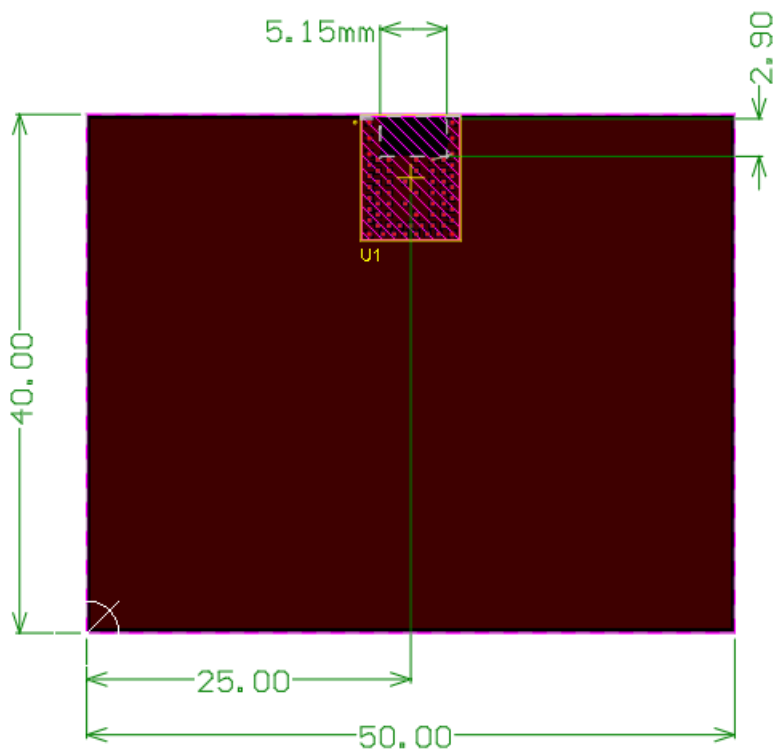

Figure 10: BMD-380 recommended RF layout and ground plane

6.2 Mechanical enclosure

Care should be taken when designing and placing the BMD-380 module into an enclosure. Metal should be kept clear from the antenna area, both above and below. Any metal around the module can negatively impact RF performance.

The module is designed and tuned for the antenna and RF components to be in free air. Any potting, epoxy fill, plastic over-molding, or conformal coating can negatively impact RF performance and must be evaluated by the customer.

6.3 Antenna patterns

Antenna patterns are based on the BMD-380 Evaluation Kit with a ground plane size of 109 mm x 56 mm. The X-Y-Z orientation is shown in [Figure 11](#):

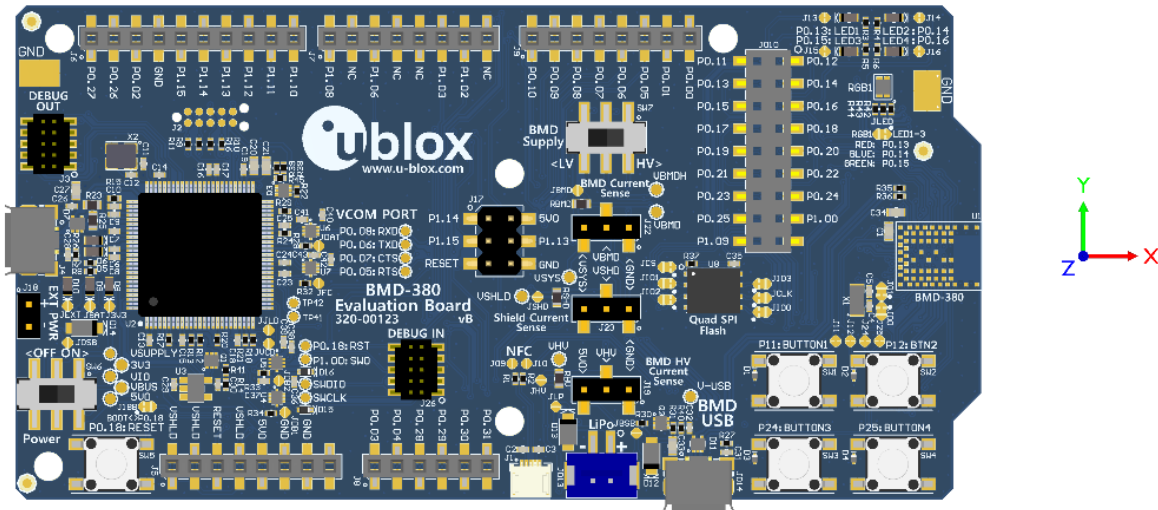

Figure 11: X-Y-Z antenna orientation

6.3.1 X-Y plane

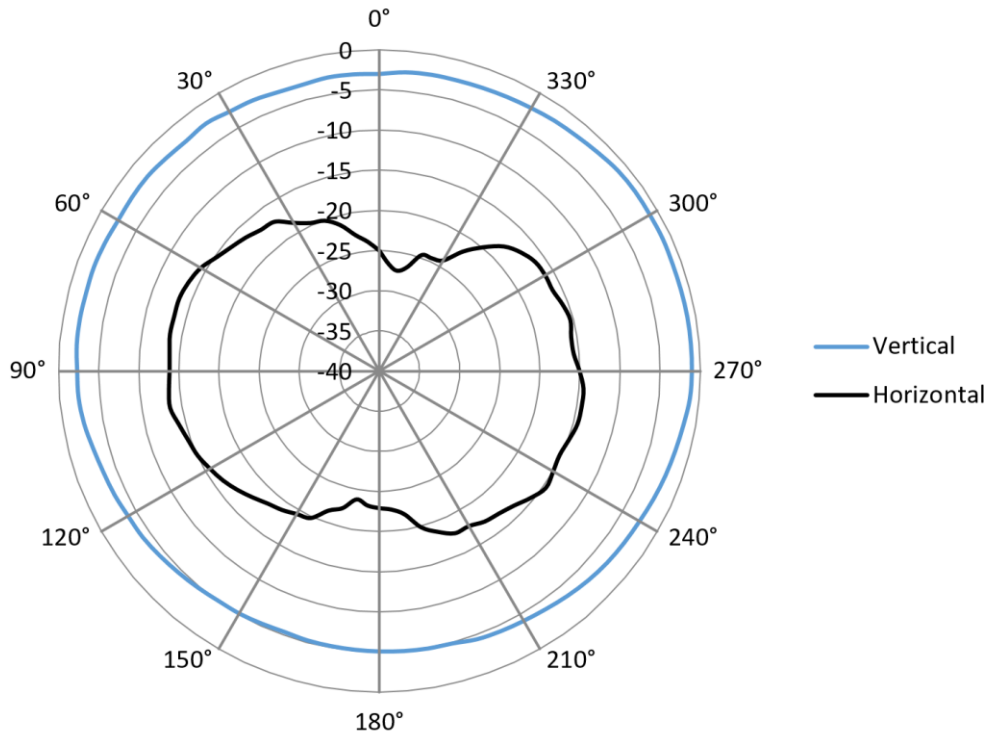

Figure 12: X-Y plane antenna pattern

6.3.2 X-Z plane

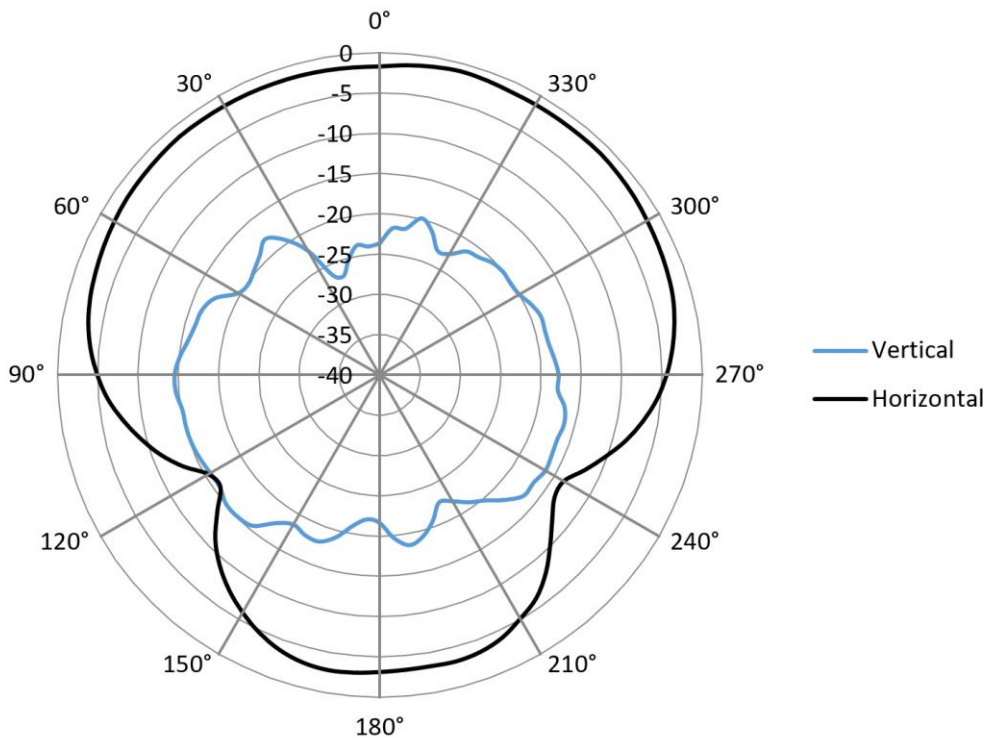

Figure 13: X-Z plane antenna pattern

6.3.3 Y-Z plane

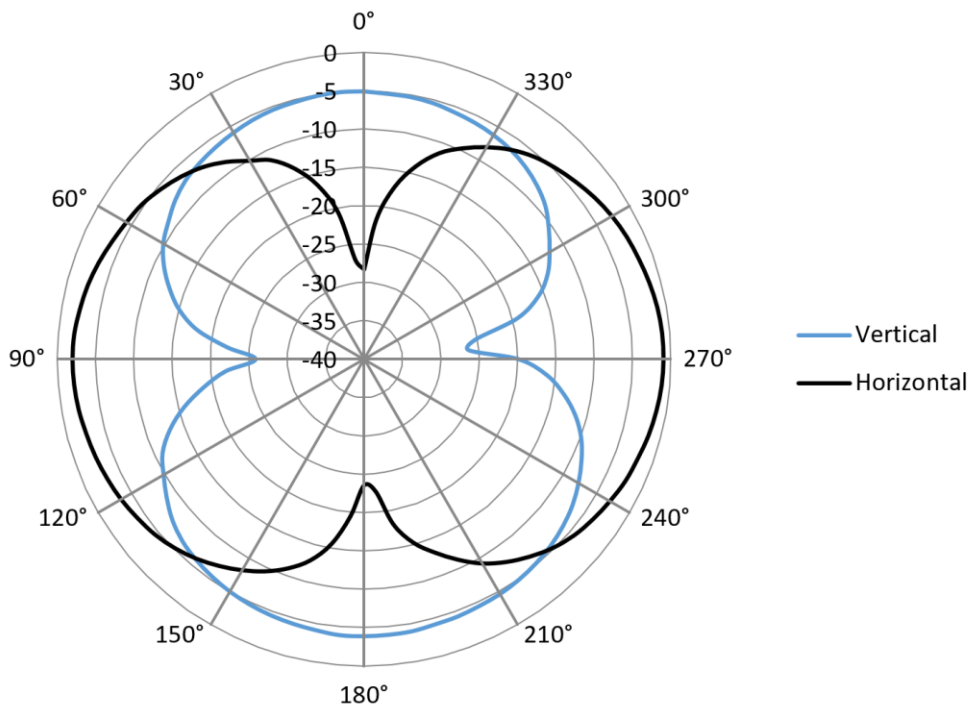

Figure 14: Y-Z plane antenna pattern

7 BMD-380 evaluation development kit

u-blox has developed full featured evaluation boards that provide a complete I/O pin out to headers, on-board programming and debugging, 32.768 kHz crystal, power, and virtual COM port over USB, BMD-380 USB connector, 64 Mb quad SPI Flash, four user LEDs, and four user buttons. The evaluation boards also provide the option to be powered from a CR2032 coin cell battery or a LiPo battery through a JST-PH connector and have current sense resistors and headers to allow for convenient current measurements. Arduino Mega style headers are provided for easy prototyping of additional functions. The evaluation boards also support programming off-board u-blox modules based on Nordic Semiconductor nRF5 SoCs.

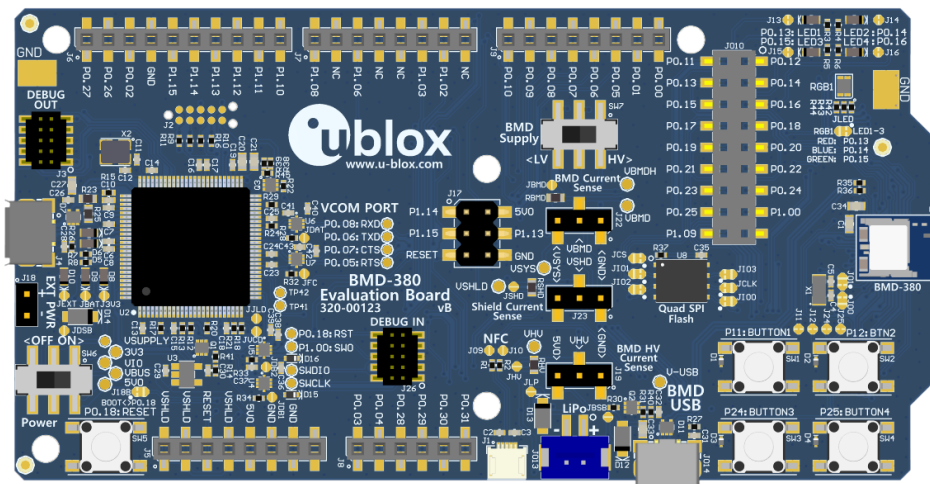

Figure 15: BMD-380 evaluation board

8 Qualification and approvals

8.1 United States (FCC)

(OEM) Integrator has to assure compliance of the entire end-product incl. the integrated RF Module. For 15 B (§15.107 and if applicable §15.109) compliance, the host manufacturer is required to show compliance with 15 while the module is installed and operating.

Furthermore, the module should be transmitting and the evaluation should confirm that the module's intentional emissions (15C) are compliant (fundamental / out-of-band). Finally, the integrator has to apply the appropriate equipment authorization (e.g., Verification) for the new host device per definition in §15.101.

The integrator is reminded to assure that these installation instructions will not be made available to the end-user of the final host device.

8.1.1 Labeling and user information requirements

The BMD-380 is assigned the FCC ID number: XPYBMD380

The final host device, into which this RF Module is integrated" has to be labeled with an auxiliary label stating the FCC ID of the RF Module, such as:

"Contains FCC ID: **XPYBMD380**

"This device complies with part 15 of the FCC rules. Operation is subject to the following two conditions:

1. This device may not cause harmful interference, and
2. This device must accept any interference received, including interference that may cause undesired operation.

"Changes or modifications to this unit not expressly approved by the party responsible for compliance could void the user's authority to operate the equipment."

 This equipment has been tested and found to comply with the limits for a Class B digital device, pursuant to part 15 of the FCC Rules. These limits are designed to provide reasonable protection against harmful interference in a residential installation. This equipment generates uses and can radiate radio frequency energy and, if not installed and used in accordance with the instructions, may cause harmful interference to radio communications. However, there is no guarantee that interference will not occur in a particular installation. If this equipment does cause harmful interference to radio or television reception, which can be determined by turning the equipment off and on, the user is encouraged to try to correct the interference by one or more of the following measures:

- Reorient or relocate the receiving antenna.
- Increase the separation between the equipment and receiver.
- Connect the equipment into an outlet on a circuit different from that to which the receiver is connected.
- Consult the dealer or an experienced radio/TV technician for help.

8.1.2 RF exposure

 The Integrator will be responsible to satisfy SAR/ RF Exposure requirements, when the module integrated into the host device.

All transmitters regulated by FCC must comply with RF exposure requirements. [KDB 447498 General RF Exposure Guidance](#) provides guidance in determining whether proposed or existing transmitting facilities, operations or devices comply with limits for human exposure to Radio Frequency (RF) fields adopted by the Federal Communications Commission (FCC).

This module is approved for installation into mobile and/or portable host platforms and must not be co-located or operating in conjunction with any other antenna or transmitter except in accordance with FCC multi-transmitter guidelines. End users must be provided with transmitter operating conditions for satisfying RF Exposure compliance.

8.2 Canada (ISED)

The BMD-380 module is certified for use in Canada under Innovation, Science and Economic Development Canada (ISED) Radio Standards Specification (RSS) RSS-247 Issue 2 and RSSGen.

8.2.1 Labeling and user information requirements

The final host device, into which this RF Module is integrated has to be labeled with an auxiliary label stating the IC of the RF Module, such as:

“Contains transmitter module IC: 8595A-BMD380

This device complies with Industry Canada license-exempt RSS standard(s). Operation is subject to the following two conditions:

1. This device may not cause interference, and
2. This device must accept any interference, including interference that may cause “undesired operation of the device.”

Le périphérique hôte final, dans lequel ce module RF est intégré "doit être étiqueté avec une étiquette auxiliaire indiquant le CI du module RF, tel que"

“Contient le module émetteur IC: 8595A-BMD380

Le présent appareil est conforme aux CNR d'Industrie Canada applicables aux appareils radio exempts de licence. L'exploitation est autorisée aux deux conditions suivantes:

1. L'appareil ne doit pas produire de brouillage, et
2. L'utilisateur de l'appareil doit accepter tout brouillage radioélectrique subi, même si le brouillage est susceptible d'en compromettre le fonctionnement. “

8.2.2 RF exposure

All transmitters regulated by ISED must comply with RF exposure requirements listed in RSS-102 - Radio Frequency (RF) Exposure Compliance of Radiocommunication Apparatus (All Frequency Bands). This module is approved for installation into mobile and/or portable host platforms and must not be co-located or operating in conjunction with any other antenna or transmitter except in accordance with Industry Canada's multi-transmitter guidelines. End users must be provided with transmitter operating conditions for satisfying RF Exposure compliance.

8.3 European Union regulatory compliance

Information about regulatory compliance of the European Union for the BMD-380 module is available in the BMD-380 Declaration of Conformity.

8.3.1 Radio Equipment Directive (RED) 2014/53/EU

The BMD-380 module complies with the essential requirements and other relevant provisions of Radio Equipment Directive (RED) 2014/53/EU.

8.4 Australia / New Zealand (RCM)

The BMD-380 has been tested to comply with the AS/NZS 4268:2017, Radio equipment and systems – Short range devices – Limits and methods of measurement. The report may be obtained from your local FAE and may be used as evidence in obtaining permission to use the Regulatory Compliance Mark (RCM).

Information on registration as a Responsible Party, license and labeling requirements may be found at the following websites:

Australia: <http://www.acma.gov.au/theACMA/radiocommunications-short-range-devices-standard-2004>

New Zealand: <http://www.rsm.govt.nz/compliance>

Only Australian-based and New Zealand-based companies who are registered may be granted permission to use the RCM. An Australian-based or New Zealand-based agent or importer may also register as a Responsible Party to use the RCM on behalf of a company not in Australia or New Zealand.

8.5 Bluetooth qualification

The Bluetooth SIG maintains the Bluetooth Specification and ensures that products are properly tested and comply with the Bluetooth license agreements. Companies that list products with the Bluetooth SIG are required to be members of the SIG and submit the listed fees. Refer to this link for details: <https://www.bluetooth.com/develop-with-bluetooth/qualification-listing>

The BMD-380 Bluetooth low energy module based on Nordic Semiconductor SoCs is listed as a “Tested Component”. This allows an end product based on a u-blox module to inherit the component listings without the need to run all of the tests again. The end product will often inherit several different listings, known as Qualified Design IDs (QDID), and are identified on a “Declaration of Compliance”.

The list of qualified products is found here: <https://launchstudio.bluetooth.com/Listings/Search>

The BMD-380 primarily utilizes the S140 SoftDevice.

9 Environmental

9.1 RoHS

BMD-380 modules are in compliance with Directive 2011/65/EU, 2015/863/EU of the European Parliament and the Council on the restriction of the use of certain hazardous substances in electrical and electronic equipment.

9.2 REACH

BMD-380 modules do not contain the [SVHC \(Substance of Very High Concern\)](#), as defined by Directive EC/1907/2006 Article according to REACH Annex XVII.

9.3 California proposition 65 (P65)

This product can expose you to Nickel (metallic), which is known to the State of California to cause cancer. For more information go to www.P65Warnings.ca.gov.

 Warnings are not required where the listed chemical is inaccessible to the average user of the end product.

10 Product handling

10.1 Packaging

10.1.1 Reel packaging

Modules are packaged on 330 mm reels loaded with 1000 modules. Each reel is placed in an antistatic bag with a desiccant pack and humidity card and placed in a 370 x 355 x 56 mm box. See the u-blox package information guide [1] for full specifications on reel dimensions, box sizes and shipping label content. BMD-380 uses u-blox reel type A2.

10.1.2 Carrier tape dimensions

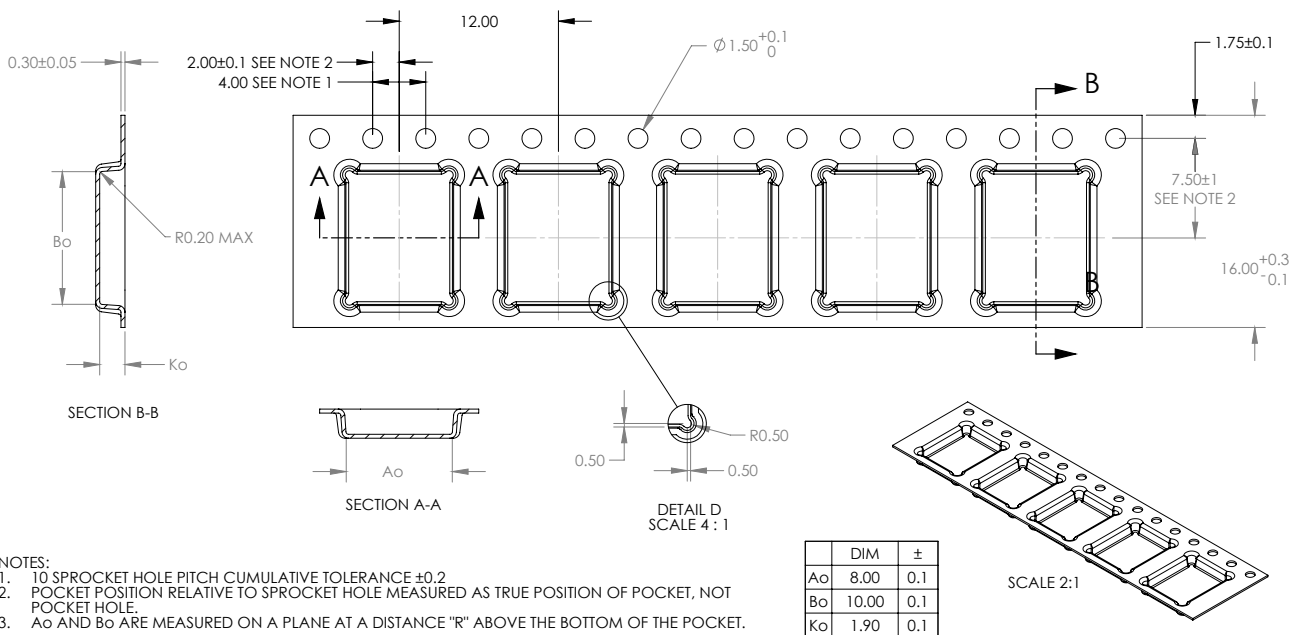

Figure 16: Carrier tape dimensions

10.2 Carrier tape orientation

BMD-380 modules are positioned in the carrier tape with the antenna oriented toward the sprocket holes. See Figure 17.

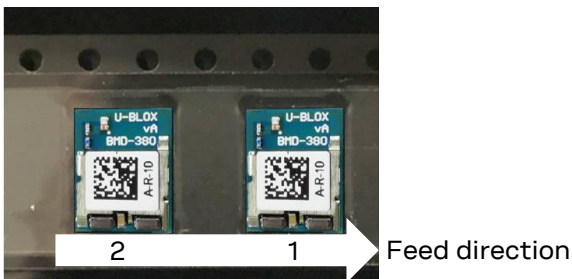

Figure 17: Carrier tape orientation

☞ “Feed direction” is defined in such a way that at the customer’s assembly line a module is first picked at position “1” and then picked at position “2”.

10.3 Moisture sensitivity level

The BMD-380 is rated for MSL 3, 168-hour floor life after opening.

10.4 Reflow soldering

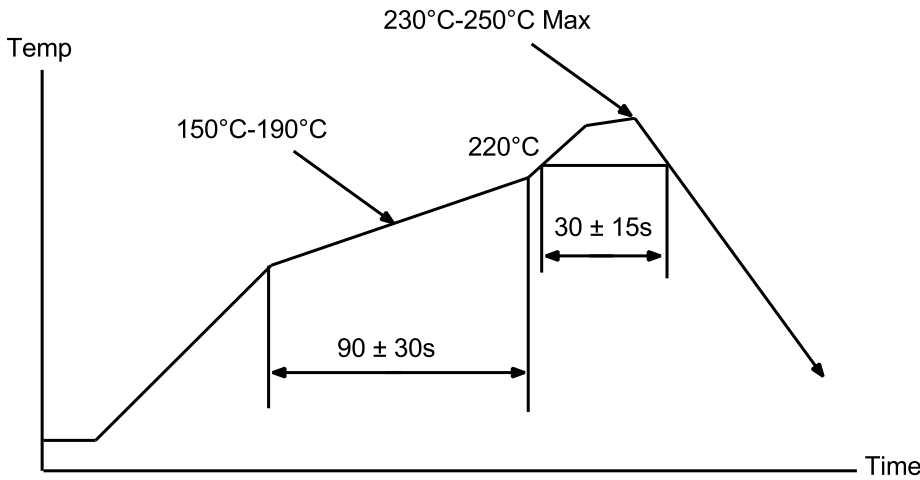

Figure 18: Reflow profile for lead free solder

10.5 ESD precautions

- ⚠ The BMD-380 module contains highly sensitive electronic circuitry and is an Electrostatic Sensitive Device (ESD). Handling the BMD-380 module without proper ESD protection may destroy or damage them permanently.

Proper ESD handling and packaging procedures must be applied throughout the processing, handling, and operation of any application that incorporates the BMD-380 module. Failure to observe these recommendations can result in severe damage to the device.

11 Ordering information

Ordering Code	Product
BMD-380-A-R	BMD-380 module, Rev A, nRF52840-QIAA, Tape & Reel, 1000-pieces per reel
BMD-380-EVAL	BMD-380 evaluation kit w/ SEGGER J-Link-OB debug probe

Table 13: Product ordering codes

12 Life support and other high-risk warnings

This product is not designed nor intended for use in a life support device or system, nor for use in other fault-intolerant, hazardous or other environments requiring fail-safe performance, such as any application in which the failure or malfunction of the product could lead directly or indirectly to death, bodily injury, or physical or property damage (collectively, “High-Risk Environments”).

 u-blox expressly disclaims any express or implied warranty of fitness for use in high-risk environments.

The customer using this product in a High-Risk Environment agrees to indemnify and defend u-blox from and against any claims and damages arising out of such use.

Related documents

- [1] u-blox package information guide, doc. no. [UBX-14001652](#)
- [2] Nordic Semiconductor, [nRF52840 Product Specification](#)
- [3] Nordic Semiconductor, [nRF5 Software Development Kit](#)

 For regular updates to u-blox documentation and to receive product change notifications, register on our homepage (www.u-blox.com).

Revision history

Revision	Date	Name	Comments
0.5	16-Apr-2019		Preliminary release for engineering samples.
0.6	10-May-2019		Added reference to S340 SoftDevice. Updated Nordic Semiconductor links Updated HV power output specifications. Updated RC Oscillator specifications
R03	12-Dec-2019		Product / document status updated to Engineering sample. Document converted from Rigado BMD-380 Data Sheet to u-blox BMD-380 data sheet. Added dimension drawing (section 5.1).
R04	20-Dec-2019	brec	Corrected antenna patterns legends, added antenna gain, corrected PWM and GPIO references, added pin land pad dimensions
R05	08-May-2020	brec	Added type number BMD-380-A-R-10, added module marking information for new type number, updated product photo, clarified PWM feature, corrected block diagram, updated US and Canada RF statements, minor typographical corrections, removed QSPI pin suggestions in Table 2, corrected pin numbers in Table 7, added suggested RF ground plane in Figure 10
R06	10-July-2020	brec, lalb	Changed product/document status to Initial Production. Removed information about the Engineering Sample ordering code/type number BMD-380-A-R-00. Removed "pending" notes for certifications for Europe, US, Canada, Australia/New Zealand and Bluetooth qualification as certifications are completed, updated revisions of the completed European regulatory tests. Updated Bluetooth qualification to v5.1
R07	22-Jun-2022	brec	Added Carrier tape orientation . Removed ambiguous description of operating condition ranges in Electrical specifications . Added ESD precautions . Updated contact information.

Contact

For further support and contact information, visit us at www.u-blox.com/support.

X-ON Electronics

Largest Supplier of Electrical and Electronic Components

Click to view similar products for [Bluetooth Modules - 802.15.1 category](#):

Click to view products by [U-Blox manufacturer](#):

Other Similar products are found below :

[CYW20732S](#) [968EMB0019](#) [BM83SM1-00AA](#) [BM833](#) [ESP32-S2-MINI-2-N4](#) [ESP32-S2-MINI-2-N4R2](#) [ESP32-S2-SOLO-2-N4](#) [ESP32-S3-MINI-1U-N8](#) [ATWINC1510-MR210PB1976](#) [RC2202A](#) [RN4020-V/RMBEC133](#) [1327](#) [WT32I-A-AI6](#) [RN42HID-I/RM](#) [RN4678-V/RM100](#) [ENW-89829C3KF](#) [BM64SPKA1MC2-0001AA](#) [BT800-ST-01-T/R](#) [SPBTLE-RFTR](#) [451-00001](#) [ENW89837AWKF](#) [RN4871-I/RM128](#) [BM23SPKA1NB9-0B02AA](#) [BM71BLES1FC2-0B02AA](#) [RN4870-I/RM130](#) [BM78SPPS5MC2-0004AA](#) [BM70BLES1FC2-0B03AA](#) [BM78SPP05MC2-0004AA](#) [BM70BLE01FC2-0B03AA](#) [WSM-BL241-ADA-008](#) [ENW89837A5KF](#) [BGM113A256V2R](#) [ARTIK-020-AV2](#) [902-0110-000](#) [MBH7BLZ07-109033](#) [FWM8BLZ02-109042](#) [UGMZ2AA001A](#) [ACN52832](#) [A2541E24A10GM](#) [RN42-I/RM630](#) [450-0168R](#) [FC6A-PC4](#) [MOTG-BLUETOOTH](#) [SPBTLE-1S](#) [88980124](#) [ABBTM-NVC-MDCS42A](#) [ACN52840](#) [4076](#) [4077](#) [4078](#)