

M2-JODY-W2

M.2 card for the JODY-W2 Wi-Fi 5 and Bluetooth 5.2 module

Data sheet



Abstract

This technical data sheet describes the M2-JODY-W2 card module which offers 1x1 802.11n/ac and dual-mode Bluetooth 5.2 in an M.2 Key E form factor. The M2-JODY-W2 card provides all the features and functionality supported in the JODY-W2 module, with the added benefits associated with easy installation and replacement. The card can be inserted in a standard M.2 Key E slot without the need to solder the module on a host or carrier PCB.

Document information

Title	M2-JODY-W2	
Subtitle	M.2 card for the JODY-W2 Wi-Fi 5 and Bluetooth 5.2 module	
Document type	Data sheet	
Document number	UBX-21008472	
Revision and date	R06	20-Mar-2024
Disclosure restriction	C1-Public	

Product status	Corresponding content status	
Functional sample	Draft	For functional testing. Revised and supplementary data will be published later.
In development / Prototype	Objective specification	Target values. Revised and supplementary data will be published later.
Engineering sample	Advance information	Data based on early testing. Revised and supplementary data will be published later.
Initial production	Early production information	Data from product verification. Revised and supplementary data may be published later.
Mass production / End of life	Production information	Document contains the final product specification.

This document applies to the following products:

Product name	Chipset	Type number	IN/PCN reference	Product status
M2-JODY-W263	NXP 88W8987	M2-JODY-W263-00C-00	N/A	Initial production

u-blox or third parties may hold intellectual property rights in the products, names, logos and designs included in this document. Copying, reproduction, or modification of this document or any part thereof is only permitted with the express written permission of u-blox. Disclosure to third parties is permitted for clearly public documents only.

The information contained herein is provided "as is". No warranty of any kind, either express or implied, is made in relation to the accuracy, reliability, fitness for a particular purpose or content of this document. This document may be revised by u-blox at any time. For most recent documents, please visit www.u-blox.com.

Copyright © u-blox AG.

Contents

Document information	2
Contents	3
1 Functional description	5
1.1 Overview.....	5
1.2 Product features.....	5
1.3 Product description.....	6
1.4 Block diagram.....	6
2 Interfaces	7
2.1 Boot configuration pins.....	7
2.2 SDIO.....	8
2.3 UART.....	8
2.4 PCM/I2S.....	8
3 Pin definition	9
3.1 Pin assignment.....	9
3.2 Pin description.....	10
4 Electrical specifications	13
4.1 Absolute maximum ratings.....	13
4.2 Maximum ESD ratings.....	13
4.3 Operating conditions.....	13
4.1 Power consumption.....	13
4.2 Digital pad ratings.....	14
4.3 Radio specifications.....	14
4.3.1 Bluetooth.....	14
4.3.2 Wi-Fi.....	14
5 Antenna connectors	17
6 Voltages	18
7 Test points	20
8 Mechanical specification	21
8.1 Physical dimensions.....	21
9 Software	22
10 Approvals	23
10.1 Configuration of Wi-Fi transmit power limits.....	23
10.1.1 Wi-Fi power table.....	23
11 Product handling	24
11.1 Packaging.....	24
11.2 Shipment, storage, and handling.....	24
11.2.1 ESD handling precautions.....	24
12 Labeling and ordering	25
12.1 Ordering codes.....	26

Appendix	27
A Wi-Fi Tx output power limits	27
A.1. FCC/ISED regulatory domain	27
A.1.1. Wi-Fi Output power for 2.4 GHz band	27
A.1.2. Wi-Fi output power for 5 GHz band.....	27
B Glossary	29
Related documentation	30
Revision history	30
Contact	30

1 Functional description

1.1 Overview

The M2-JODY-W2 card integrates the JODY-W2 multi-radio module, based on the NXP 88W8987 chipset. The Type 2230 Key E M.2 card supports all features and functionality of the module on a convenient expansion card that plugs directly to the host platform.

JODY-W2 modules can be operated in the following modes:

- Wi-Fi 1x1 802.11a/b/g/n/ac in 2.4 GHz or 5 GHz bands
- Dual-mode Bluetooth 5, including audio, can be operated simultaneously with Wi-Fi

Even though the M2-JODY-W2 card is of standard grade, the module variant used on the card is the JODY-W263-00B professional grade module.

1.2 Product features

As the M2-JODY-W2 card supports all the features supported in the JODY-W2 module that it integrates, this document aims to describe the extended features of the M2-JODY-W2 card specifically. For more information about the JODY-W2 module, see the JODY-W2 series data sheet [1]. [Table 1](#) describes the features of the M2-JODY-W2 module.

M2-JODY-W263	
Grade	
Automotive	
Professional	
Standard	•
Radio	
Chip inside	NXP 88W8987
Bluetooth qualification	v5.2
Bluetooth profiles	HCI
Bluetooth BR/EDR	•
Bluetooth Low Energy	•
Wi-Fi IEEE 802.11 standards	a/b/g/n/ac
Wi-Fi 2.4 / 5 [GHz]	2.4 and 5
Max output power at antenna pin [dBm]	18
Antenna type	2 U.FL connectors
OS support	
Android / Linux drivers (from u-blox)	•
Interfaces	
UART ^B	1
SDIO [version] ^W	v3
PCM (Bluetooth audio)	1
Features	
Micro Access Point [max connects]	8
AES hardware support	•
RF parameters in OTP memory	•
MAC addresses in OTP memory	•

B = For Bluetooth only
W = For Wi-Fi only

Table 1: Key features of the M2-JODY-W2 module

1.3 Product description

Product name	Description
M2-JODY-W2	Standard grade M.2 card module with two antenna connectors (one for 2.4 GHz and 5 GHz 802.11 ac and another for Bluetooth/Bluetooth Low Energy (LE) 5.2). NXP chipset 88W8987

Table 2: Product description

1.4 Block diagram

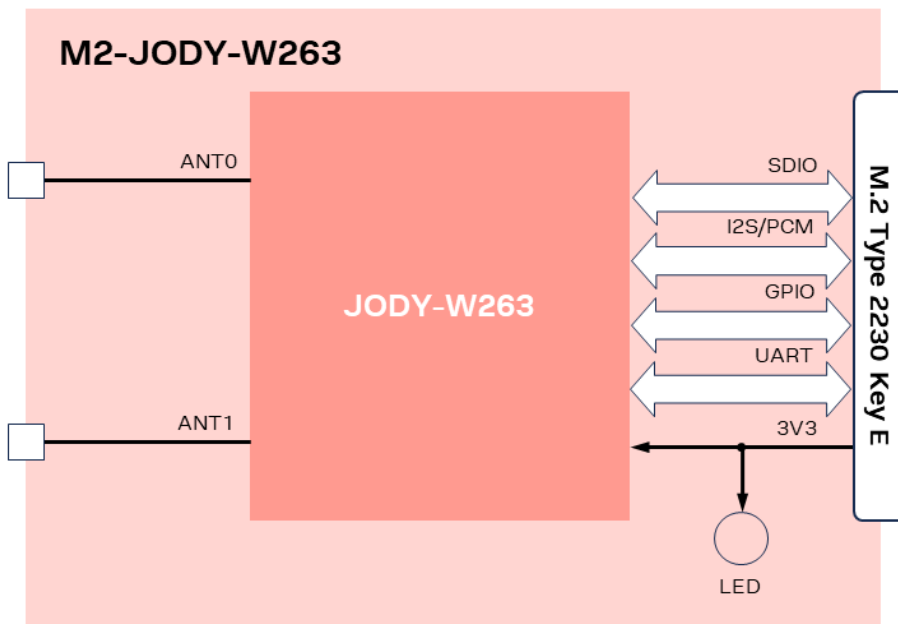

Figure 1: Block diagram of the M2-JODY-W2 card module

2 Interfaces

The M2-JODY-W2 card supports all JODY-W2 module interfaces. For more information about these interfaces, see the JODY-W2 series data sheet [1].

2.1 Boot configuration pins

By default, the M2-JODY-W2 card is configured for using the SDIO interface for Wi-Fi and the UART interface for Bluetooth.

Host interface selection and firmware boot options are selected using the JODY-W2 module configuration pins **CONFIG[1]** and **CONFIG[0]**. The configuration settings for the available boot options are shown in Table 3.

CONFIG[1]	CONFIG[0]	Wi-Fi	Bluetooth	Firmware download	Number of SDIO functions
1	0	SDIO	UART	SDIO+UART (parallel/serial)	1 (Wi-Fi)
1	1	SDIO	SDIO	SDIO+SDIO (parallel/serial) ¹	2 (Wi-Fi, Bluetooth)

¹ SDIO+SDIO configuration requires a different firmware image and soldering of a pull-down resistor.

Table 3: Firmware boot options of the JODY-W2 module

The M2-JODY-W2 card supports the same boot options as the JODY-W2 module. To set any **CONFIG[1:0]** configuration pin to logic-low level (“0”), it must be pulled down with a 100 kΩ resistor to GND. JODY-W2 has internal pull-up resistors and as a result, no external pull-up resistors are required to set a configuration pin to logic-high level (“1”).

Figure 2 shows the “10” default configuration used to select the SDIO interface for Wi-Fi and UART interface for Bluetooth.

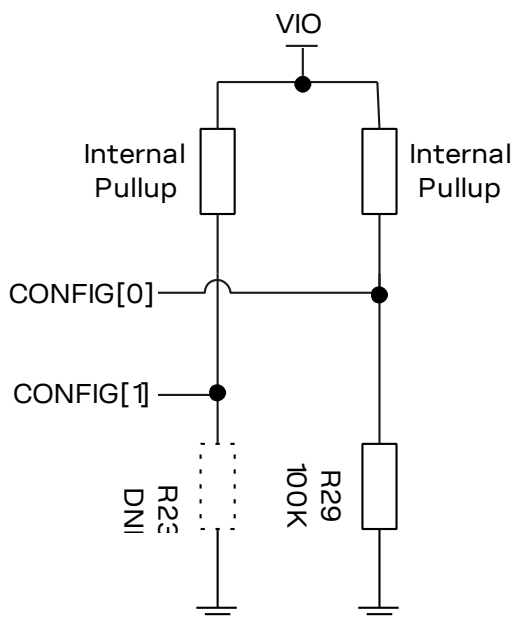

Figure 2: Default configuration of the M2-JODY-W2 boot pins

Figure 3 shows the physical locations of pulldown resistor positions, R23 and R29.

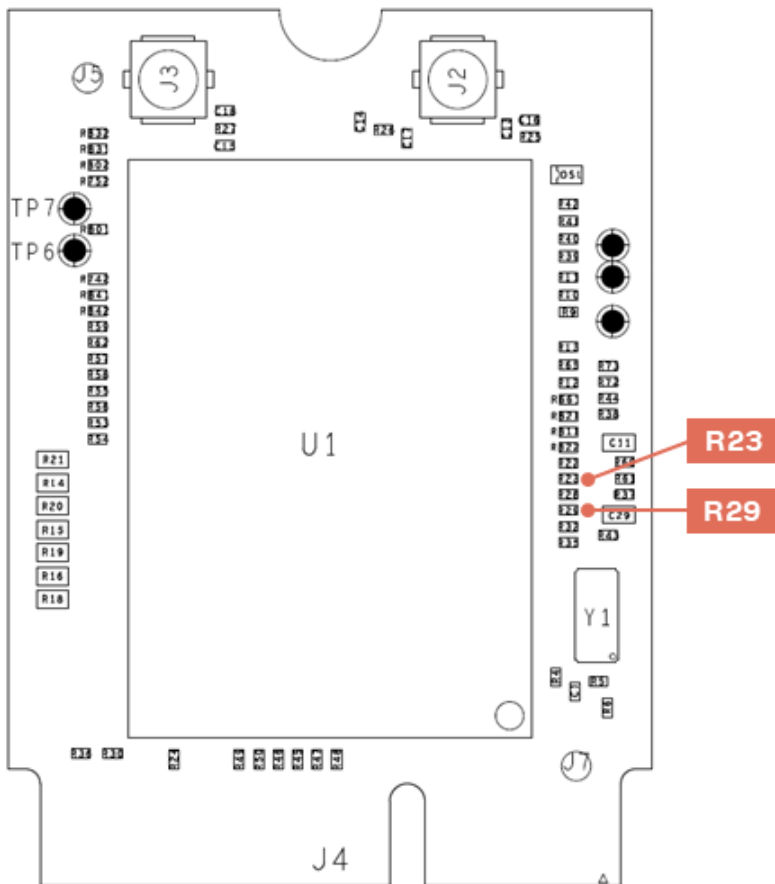

Figure 3: Position of resistors R23 and R29 on M2-JODY-W2 (top side)

2.2 SDIO

The SDIO device interface is conformant with the industry standard SDIO 3.0 specification (UHS-I up to 104 MB/s) and allows a host controller to access JODY-W2 Wi-Fi (and optionally, Bluetooth) functionality using the SDIO bus protocol. The interface supports 4-bit SDIO transfer mode over the full clock range up to 208 MHz. All bus speed modes are supplied from a 1.8 V power supply.

2.3 UART

JODY-W2 series modules support a high-speed UART interface that is conformant with the industry-standard 16550 specification. For information about the features and baud rates supported in the JODY-W2 series high-speed UART, see the JODY-W2 data sheet [1].

2.4 PCM/I2S

M2-JODY-W2 supports the full functionality of the JODY-W2 series PCM and I2S interfaces for audio. The pins of the PCM and I2S interfaces are shared.

3 Pin definition

The M2-JODY-W2 card module implements the standard pinout of M.2 mechanical Type E sockets as defined by the PCI Express M.2 Specification [5]. In co-operation with NXP, the card fully supports the optional sideband and debug signals as defined by the NXP Wi-Fi/Bluetooth M.2 Key E Pinout Definition [6].

3.1 Pin assignment

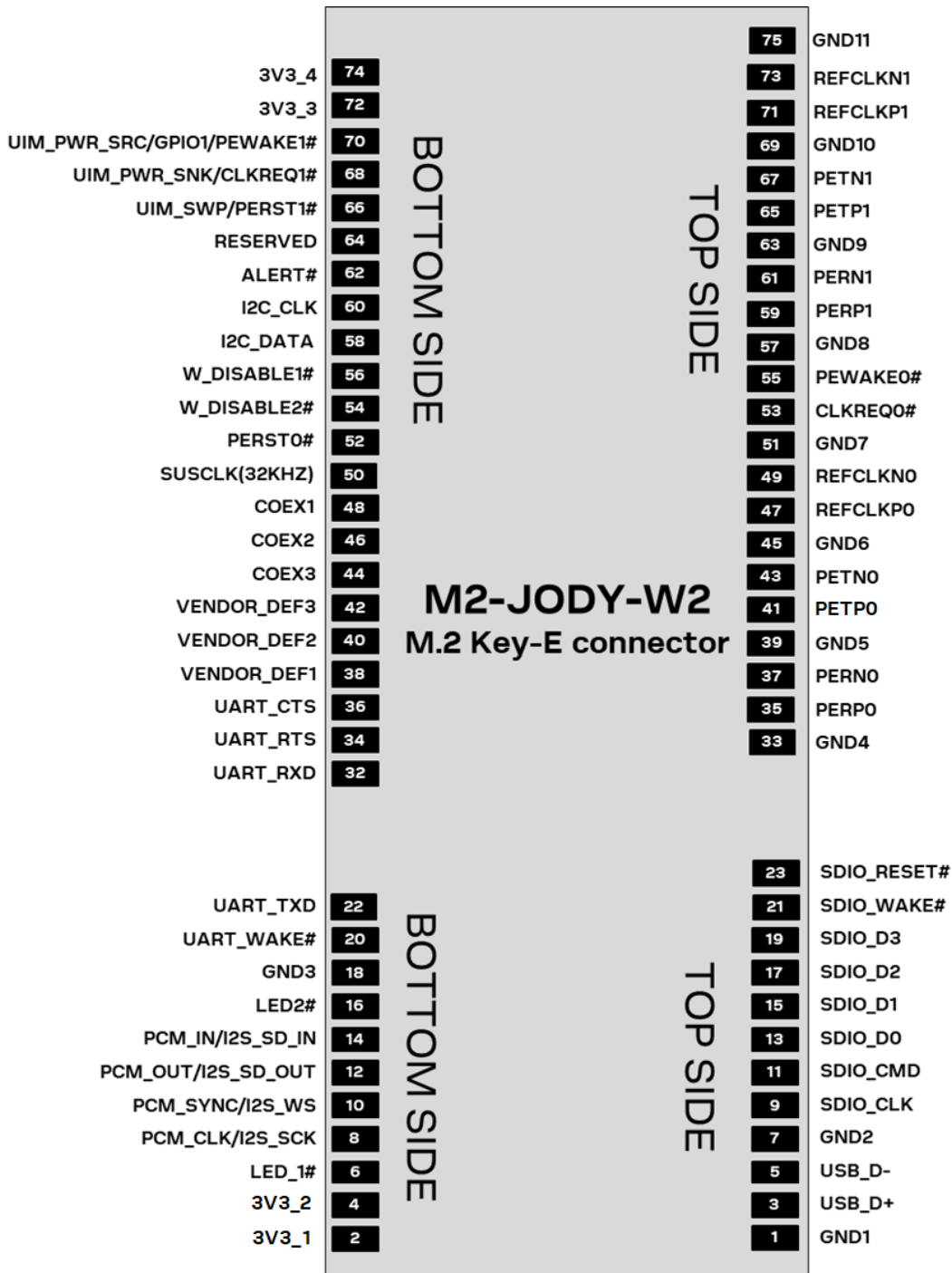

Figure 4: M2-JODY-W2 pin assignment

3.2 Pin description

Table 4 and Table 5 describe the M2-JODY-W2 pins located at the top and bottom side of the M.2 card, respectively. The signal direction of the pins (inputs or outputs) is shown from the M2-JODY-W2 card perspective.

Pin no.	Pin name	Pin type	Voltage	Description
1	GND1	GND		Ground
3	USB_D+	NC		USB data + serial data interface. Not connected
5	USB_D-	NC		USB data - serial data interface. Not connected
7	GND2	GND		Ground
9	SDIO_CLK	I	1V8	SDIO Clock
11	SDIO_CMD	I/O	1V8	SDIO Command
13	SDIO_D0	I/O	1V8	SDIO Data 1
15	SDIO_D1	I/O	1V8	SDIO Data 2
17	SDIO_D2	I/O	1V8	SDIO Data 3
19	SDIO_D3	I/O	1V8	SDIO Data 4
21	SDIO_WAKE#	O	VIO	NXP usage: WLAN_WAKE_HOST . Sideband signal used by the Wi-Fi radio to wake up the platform. Active Low by default. Connect to Host GPIO Open drain. Pullup required on platform
23	SDIO_RESET#	I	VIO	NXP usage: WLAN_INDEPENDENT_RESET . Sideband signal to independently reset the Wi-Fi radio. Active Low by default. Connect to Host GPIO
M.2 Key E connector notch				
33	GND4	GND		Ground
35	PERP0	NC		PCIe RX. Not connected
37	PERN0	NC		PCIe RX. Not connected
39	GND5	GND		Ground
41	PETP0	NC		PCIe TX. Not connected
43	PETN0	NC		PCIe TX. Not connected
45	GND6	GND		Ground
47	REFCLKP0	NC		PCIe Reference Clock. Not connected
49	REFCLKN0	NC		PCIe Reference Clock. Not connected
51	GND7	GND		Ground
53	CLKREQ0#	NC		PCIe Clock Request. Not connected
55	PEWAKE0#	NC		PCIe PME Wake. Not connected
57	GND8	GND		Ground
59	PERP1	NC		PCIe RX. Not connected
61	PERN1	NC		PCIe RX. Not connected
63	GND9	GND		Ground
65	PETP1	NC		PCIe TX. Not connected
67	PETN1	NC		PCIe TX. Not connected
69	GND10	GND		Ground

Pin no.	Pin name	Pin type	Voltage	Description
71	REFCLKP1	NC		PCIe Reference Clock. Not connected
73	REFCLKN1	NC		PCIe Reference Clock. Not connected
75	GND11	GND		Ground

Table 4: M2-JODY-W2 pinout – top side

Pin no.	Pin name	Pin type	Voltage	Description
2	3V3_1	P	3.3 V	Supply voltage pin
4	3V3_2	P	3.3 V	Supply voltage pin
6	LED_1#	NC		Not connected
8	PCM_CLK/I2S_SCK	I/O	VIO	PCM data clock
10	PCM_SYNC/I2S_WS	I/O	VIO	PCM frame sync
12	PCM_OUT/I2S_SD_OUT	O	VIO	PCM data output
14	PCM_IN/I2S_SD_IN	I	VIO	PCM data input
16	LED2#	NC		Not connected
18	GND3	GND		Ground
20	UART_WAKE#	O	3.3 V	NXP usage: BT_WAKE_HOST . Sideband signal used by the Bluetooth radio to wake up the platform. Active Low by default. Connect to Host GPIO Open drain. Pullup required on platform. See footnote ¹ .
22	UART_TXD	O	VIO	UART transmit. Connected to host platform UART receive (UART_RXD)
M.2 Key E connector notch				
32	UART_RXD	I	VIO	UART receive. Connected to host platform UART transmit (UART_TXD)
34	UART_RTS	O	VIO	UART Request-To-Send. Connected to host platform UART Clear-To-Send (UART_CTS)
36	UART_CTS	I	VIO	UART Clear-To-Send. Connected to host platform UART Request-To-Send (UART_RTS)
38	VENDOR_DEF1	I/O	VIO	NXP usage: JTAG_TDO . Used for debug. Not connected
40	VENDOR_DEF2	I	VIO	NXP usage: DEV_WLAN_WAKE . Sideband signal used by the platform to wake up the Wi-Fi radio. Active Low. Connect to Host GPIO
42	VENDOR_DEF3	I	VIO	NXP usage: DEV_BT_WAKE . Sideband signal used by the platform to wake up the Bluetooth radio. Active Low. Connect to Host GPIO
44	COEX3	I/O	VIO	NXP usage: JTAG_TDI Used for debug. Not connected
46	COEX2	I/O	VIO	NXP usage: JTAG_TCK . Used for debug. Not connected
48	COEX1	I/O	VIO	NXP usage: JTAG_TMS . Used for debug. Not connected
50	SUSCLK(32KHZ)	NC		Not connected
52	PERST0#	NC		PCIe host indication to reset the device. Not connected
54	W_DISABLE2#	I	3.3 V	NXP usage: BT_INDEPENDENT_RESET . Sideband signal to independently reset the Bluetooth radio. Active Low by default. Connected to Host GPIO. See footnote ¹ .

Pin no.	Pin name	Pin type	Voltage	Description
56	W_DISABLE1#	I	3.3 V	NXP usage. PDn . Full Power-down for the Wi-Fi/BT radio: High = normal mode, Low = full power-down mode. Connect to Host GPIO. See footnote ¹
58	I2C_DATA	NC		I2C data. Not connected
60	I2C_CLK	NC		I2C clock. Not connected
62	ALERT#	NC		Not connected
64	RESERVED	NC		Not connected
66	UIM_SWP/PERST1#	NC		Not connected
68	UIM_PWR_SNK/CLKREQ1#	NC		Not connected
70	UIM_PWR_SRC/GPIO1/PEWAKE1#	NC		Not connected
72	3V3_3	P	3.3 V	Supply voltage pin
74	3V3_4	P	3.3 V	Supply voltage pin

Table 5: M2-JODY-W2 pinout (bottom side)

¹ It is recommended to insert a 3V3 CMOS buffer along each one of the sideband signal lines, between the host platform and the M.2 card socket. Signals **W_DISABLE1#** and **W_DISABLE2#** are outputs from the host platform and inputs to the M.2 card, therefore the buffer outputs must be connected to those signals. Signal **UART_WAKE#** is output from the M.2 card and input to the host platform, therefore the buffer input must be connected to that signal.

4 Electrical specifications

⚠ Stressing the device above one or more of the [Absolute maximum ratings](#) can cause permanent damage. These are stress ratings only. Operating the module at these or at any conditions other than those specified in the [Operating conditions](#) should be avoided. Exposure to absolute maximum rating conditions for extended periods can affect device reliability.

4.1 Absolute maximum ratings

Symbol	Description	Min.	Max.	Units
3V3	Power supply voltage	-0.3	4.0	V
T _{STORAGE}	Storage temperature	-40	+85	°C

Table 6: Absolute maximum ratings

4.2 Maximum ESD ratings

Applicability	Min.	Max.	Units
Human Body Model (HBM), according to ANSI/ESDA/JEDEC JS-001	-1500	+1500	V
Charged Device Model (CDM), according to ANSI/ESDA/JEDEC JS-002	-500	+500	V

Table 17: Maximum ESD ratings

4.3 Operating conditions

Symbol	Parameter	Min.	Typ.	Max.	Units
3V3	Power supply voltage	3.2	3.3	3.465	V
T _A	Ambient operating temperature	-40	-	+85	°C
Ripple Noise	Peak-to-peak voltage ripple on all supply lines.	-	-	10	mV

Table 18: Operating conditions

4.1 Power consumption

Peak current condition	Temperature	Supply current	Units
Active transmission at max. rated output power (WiFi)	Room temperature	0.37	A
Active transmission at max. rated output power (Bluetooth)	Room temperature	0.13	A
Firmware Initialization	Room temperature	1.0	A

Table 19: Peak current consumption

4.2 Digital pad ratings

Symbol	Parameter	VIO	Min.	Max.	Units
V _{IH}	Input high voltage	1.8 V or 3.3 V	0.7*VIO	VIO+0.4	V
V _{IL}	Input low voltage	1.8 V or 3.3 V	-0.4	0.3*VIO	V
V _{HYS}	Input hysteresis	1.8 V or 3.3 V	100	-	mV
V _{OH}	Output high voltage	1.8 V or 3.3V	VIO-0.4	-	V
V _{OL}	Output low voltage	1.8 V or 3.3 V	-	0.4	V

Table 22: DC characteristics VIO

4.3 Radio specifications

4.3.1 Bluetooth

Parameter	Specification
RF Frequency Range	2.4 – 2.5 GHz
Supported Modes	Bluetooth 5.2
Number of channels	79 (BR/EDR) 40 (LE)
Modulation	1 Mbps: GFSK (BR) 2 Mbps: $\pi/4$ DQPSK (EDR) 3 Mbps: 8DQPSK (EDR)
Transmit Power	Class 1 BR +10 dBm Class 1 EDR +9 dBm LE +8 dBm
Receiver sensitivity (typical values)	BR -87 dBm \pm 1.5 dB EDR -86 dBm \pm 1.5 dB LE -99 dBm \pm 1.5 dB

Table 23: Bluetooth radio parameters

4.3.2 Wi-Fi

M2-JODY-W2 cards support dual-band Wi-Fi with 802.11a/b/g/n/ac operation in the 2.4 GHz and 5 GHz radio bands.

Parameter	Operation mode	Specification
RF Frequency range	802.11b/g/n	2.400 – 2.500 GHz
	802.11a/n/ac	4.900 – 5.925 GHz
Modulation	802.11b	CCK and DSSS
	802.11a/g/n/ac	OFDM
Supported data rates	802.11b	1, 2, 5.5, 11 Mbps
	802.11a/g	6, 9, 12, 18, 24, 36, 48, 54 Mbps
	802.11n SISO	MCS0 - MCS7 (150 Mbps)
	802.11ac SISO	MCS0 – MCS9 (433 Mbps)

Parameter	Operation mode	Specification
Supported channel bandwidth	802.11n	20, 40 MHz
	802.11ac	20, 40, 80 MHz
Supported guard interval (GI)	802.11n	400, 800 ns
	802.11ac	Short guard interval supported

Table 24: Wi-Fi radio features and specifications

Parameter	Frequency	Operation mode	802.11 EVM limit	Specification (typ. output power tolerance ± 2 dB)
Maximum transmit power	2.4 GHz	DSSS/CCK	-9 dB	19 dBm ²
		OFDM, BPSK	-8 dB	19 dBm
		OFDM, QPSK	-13 dB	18 dBm
		OFDM, 16-QAM	-19 dB	18 dBm
		OFDM, 64-QAM, 3/4	-25 dB	17 dBm
		OFDM, 64-QAM, 5/6	-28 dB	17 dBm
	5 GHz	OFDM, BPSK	-5 dB	16 dBm
		OFDM, QPSK	-13 dB	15 dBm
		OFDM, 16-QAM	-19 dB	15 dBm
		OFDM, 64-QAM, 3/4	-25 dB	15 dBm
		OFDM, 64-QAM, 5/6	-28 dB	15 dBm
		OFDM, 256-QAM, 3/4	-30 dB	15 dBm
		OFDM, 256-QAM, 5/6	-32 dB	14 dBm

Table 25: Wi-Fi Radio maximum transmit power parameter

Band	Operating mode	Data rate	Bandwidth	Specification
2.4 GHz	802.11b	1 Mbps/2 Mbps	20 MHz	-97 dBm/-94 dBm
		5.5 Mbps/11 Mbps		-92 dBm/-88 dBm
	802.11g	6Mbps/9Mbps	-89 dBm/-88 dBm	
		12 Mbps/18 Mbps	-86 dBm/-84 dBm	
		24 Mbps/36 Mbps	-81 dBm/-79 dBm	
		48 Mbps/54 Mbps	-75 dBm/-73 dBm	
	802.11n	MCS0/MCS1	-89 dBm/-88 dBm	
		MCS2/MCS3	-86 dBm/-84 dBm	
		MCS4/MCS5	-81 dBm/-79 dBm	
		MCS6/MCS7	-75 dBm/-73 dBm	

² FCC output power limit 12 dBm

Band	Operating mode	Data rate	Bandwidth	Specification	
5 GHz	802.11a	6 Mbps/9 Mbps	20 MHz	-88 dBm/-87 dBm	
		12 Mbps/18 Mbps		-88 dBm/-86 dBm	
		24 Mbps/36 Mbps		-83 dBm/-80 dBm	
		48 Mbps/54 Mbps		-75 dBm/-74 dBm	
	802.11ac	MCS0/MCS1	20 MHz	-88 dBm/-87 dBm	
				MCS2/MCS3	-85 dBm/-82 dBm
				MCS4/MCS5	-80 dBm/-76 dBm
				MCS6/MCS7	-75 dBm/-73 dBm
				MCS8	-69 dBm
		MCS0/MCS1	40 MHz	-85 dBm/-84 dBm	
				MCS2/MCS3	-82 dBm/-79 dBm
				MCS4/MCS5	-77 dBm/-73 dBm
				MCS6/MCS7	-72 dBm/-71 dBm
				MCS8/MCS9	-67 dBm/-65 dBm
		MCS0/MCS1	80 MHz	-81 dBm/-81 dBm	
				MCS2/MCS3	-79 dBm/-76 dBm
				MCS4/MCS5	-74 dBm/-70 dBm
				MCS6/MCS7	-69 dBm/-68 dBm
				MCS8/MCS9	-63 dBm/-61 dBm

Table 26: Wi-Fi radio sensitivity

5 Antenna connectors

The M2-JODY-W2 card features two U.FL connectors, one for each of the two antenna pins:

- Connector J3 is connected to JODY-W2 pin 29 (**ANT1**) for Wi-Fi operation.
- Connector J2 is connected to JODY-W2 pin 24 (**ANT0**) for Bluetooth.

The location of the U.FL connectors on the M.2 card is shown in [Figure 5](#).

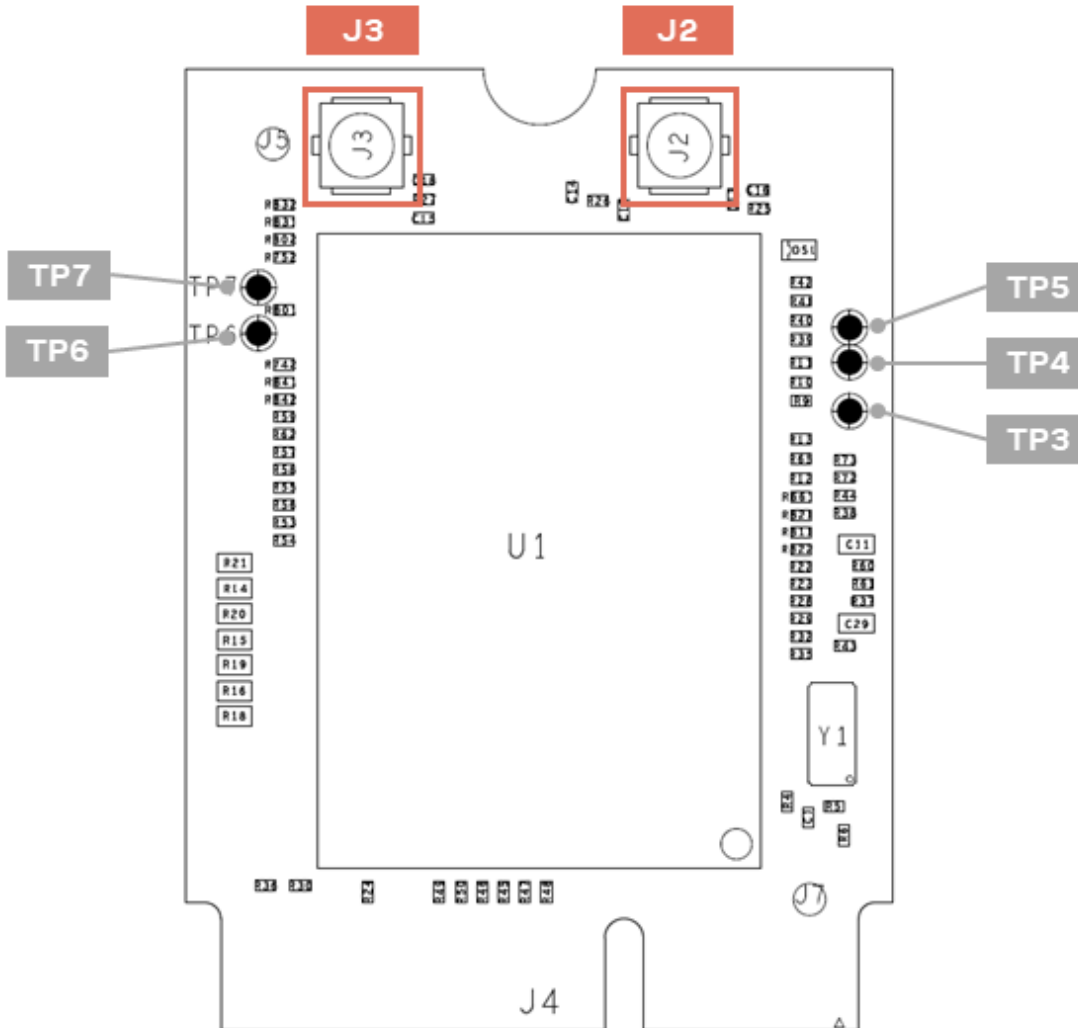



Figure 5: Location of M2-JODY-W2 antenna U.FL connectors and test points

 Given the small size and low profile of the U.FL connector, be sure to follow the manufacturer's instructions to avoid any damage when mating and un-mating the connector. See also the U.FL series guideline [\[7\]](#) and U.FL series data sheet [\[8\]](#).

6 Voltages

The M2-JODY-W2 card requires a 3.3 V power supply. The card takes the 3.3 V supply from the **3V3** pins on the M.2 connector, while the 1.8 V supply is generated by the on-card DC-DC converter.

The default setting for **VIO** is 1.8 V but this can be changed to 3.3 V by moving the 0 Ω resistor in position R1 to R7 (default = DNI), as shown on [Figure 6](#). Note that R1 and R7 share a common pad. Only one of the two resistors R1 and R7 should be present at any time.

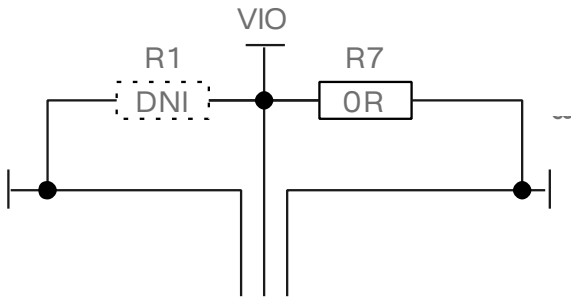

Figure 6: Placement of 0 Ω resistor to change VIO from 1V8 V to 3V3

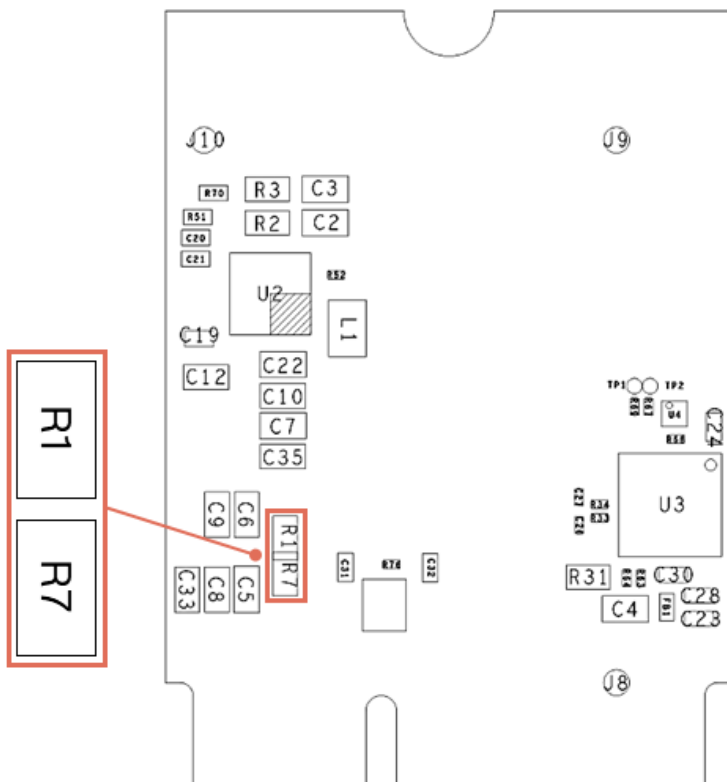

Figure 7: Position of R1 and R7 on M2-JODY-W2 (bottom side)

An on-card level-shifter (as shown on [Figure 8](#)) translates M.2 signals **W_DISABLE1#**, **W_DISABLE2#** and **UART_WAKE#** from 3.3 V to VIO. See footnote¹.

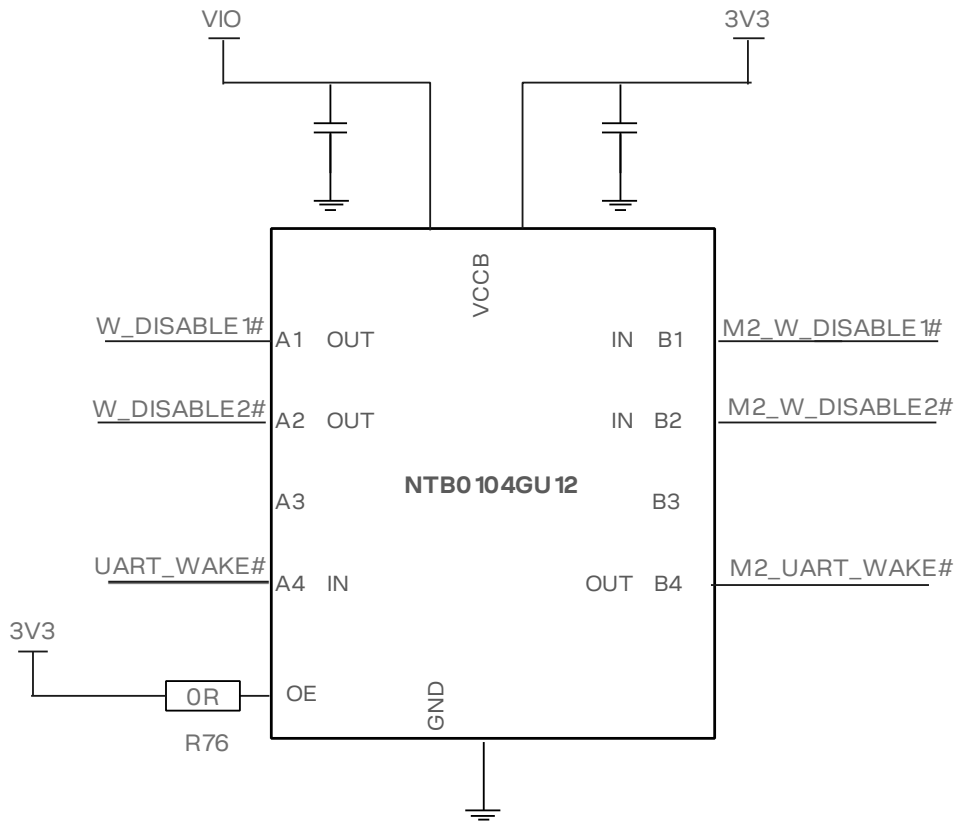

Figure 8: VIO-to-3.3 V level shifter showing M.2 signal translation

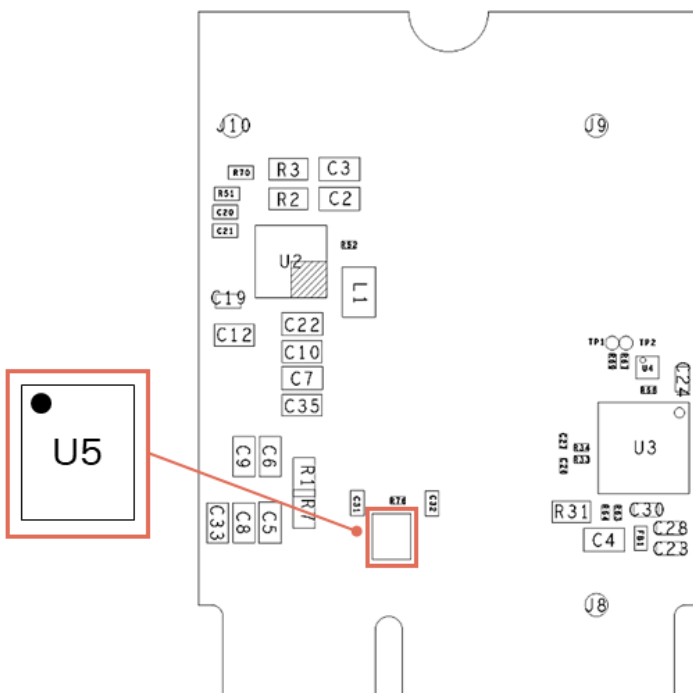

Figure 9: Position of VIO-to-3.3 V level shifter on M2-JODY-W2 (bottom side)

7 Test points

On-card test points, TP1, TP2, and TP3, allow NXP sideband signals to be probed, as shown on [Table 7](#). For information that describes how these signals are used in NXP platforms, see the [Pin description](#) tables and the NXP M.2 Key E Pinout Definition [\[6\]](#). The position of the test points on the card is shown in [Figure 5](#).

Test point #	M.2 pin#	NXP usage
TP1	21	WLAN_WAKE_HOST
TP2	20	BT_WAKE_HOST
TP3	23	WLAN_INDEPENDENT_RESET

Table 7: M.2 pin number and functionality of the M2-JODY-W2 cards test points

8 Mechanical specification

8.1 Physical dimensions

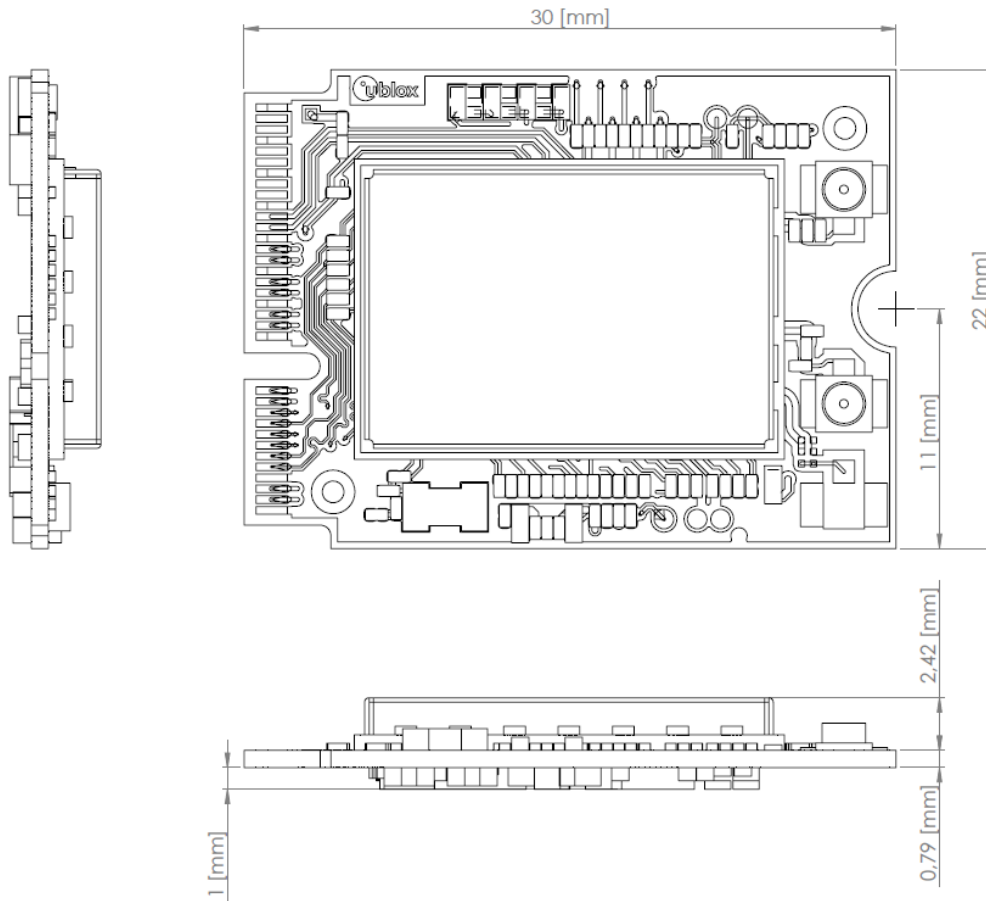

Figure 10: Physical dimensions of the M2-JODY-W2 card

9 Software

M2-JODY-W2 cards are based on the NXP 88W8987 chipset and the drivers and firmware required to operate JODY-W2 series modules are developed by NXP. A firmware binary is downloaded by the host operating system driver at start-up.

The following software options are available for the card:

- Open-source Linux/Android driver (`mxm_mwiflex`) for mainstream use is available free of charge and already integrated into the Linux BSP for NXP i.MX application processors
- Proprietary Linux/Android drivers providing different feature packs
- MCUXpresso Wi-Fi/Bluetooth support for supported NXP MCUs

The proprietary drivers are distributed by u-blox to customers that have signed a limited use license agreement (LULA-M) [9] with u-blox. The license can be signed electronically. [Contact](#) your local support team for more information. The driver package is also available directly from NXP.

The software packages typically include:

- Dedicated kernel driver that binds the Wi-Fi device to the kernel. Driver sources are provided.
- Dedicated Wi-Fi firmware image that is uploaded during initialization of the Wi-Fi device.
- Dedicated Bluetooth firmware image that is uploaded during initialization of the Bluetooth device.
- Laboratory and manufacturing tools.

10 Approvals

M2-JODY-W2 cards are designed to comply with the regulatory demands of the Federal Communications Commission (FCC), Industry Canada (IC), and European standards for CE marking.

For detailed information about regulatory compliance requirements of end products that use M2-JODY-W2 modules, see the JODY-W2 system integration manual [2].

10.1 Configuration of Wi-Fi transmit power limits

JODY-W2 modules contain calibration data for the output power limits in OTP. This calibration data enables the module to achieve maximum transmit power levels that still pass the required EVM and spectral mask limits. The maximum transmit-power levels that can be used in an end-product also depend on:

- Regulatory domain limits
- Restricted band of usage
- Gain of the antenna and antenna trace design

A configuration file on the host system and the utility `m1anut1` is used to reduce the transmit power levels as required.



Transmit power limit configuration files are provided by u-blox for the certified regulatory domains which addresses the reference designs and the approved antennas.

- ⚠ The correct transmit power limits must be applied to the module after startup of the host system or change of the regulatory domain during runtime.

10.1.1 Wi-Fi power table

The Wi-Fi power table defines the transmit power levels for the Wi-Fi radio. The power levels are based on regulatory compliance, IEEE 802.11 requirements, and product design constraints. The TX power table can be adjusted to achieve the highest transmit power level for each Wi-Fi channel, bandwidth, and modulation within the constraints defined by the certification.

The Wi-Fi power table is defined in a transmit power configuration file, `txpwrlimit_cfg_XX.conf`, where “XX” stands for the alpha2 country code. It allows developers to fine tune specific transmit power levels for the Wi-Fi radio, including:

- Band (2G and 5G)
- Channel
- Modulation rate (CCK and OFDM)
- Bandwidth (20, 40, and 80 MHz)



Transmit power configuration files for each completed certification are included in the Yocto meta-layer. Transmit power config files are named as per the name of the certification region, for example `txpwrlimit_cfg_ETSI.conf`. The configuration files are used by the recipe in the meta-layer to derive binary files, which can be automatically loaded by the driver, for each country in the certification region, such as, Germany (DE), France (FR), and so on.

For the exact power limits used for the various certifications, see the [Appendix: Wi-Fi Tx output power limits](#). The JODY-W2 system integration manual [2] contains details about configuring Wi-Fi Tx output power limits along with examples.

11 Product handling

11.1 Packaging

Packaged and shipped in trays containing multiple M.2 cards.

11.2 Shipment, storage, and handling

 For information about shipment, storage, and handling, see the Product packaging guide [\[3\]](#)

11.2.1 ESD handling precautions

 M2-JODY-W2 cards are Electrostatic Sensitive Devices (ESD) that demand the observance of special handling precautions against electrostatic damage. Failure to observe the precautions can result in severe damage to the card.

M2-JODY-W2 cards are manufactured through a highly automated process, which complies with IEC61340-5-1 (STM5.2-1999 Class M1 devices) standard. In compliance with the following European regulations, proper measures must be taken to protect M2-JODY-W2 from ESD events on any pin that might be exposed to the end user:

- ESD testing standard CENELEC EN 61000-4-2
 - Radio equipment standard ETSI EN 301 489-1
- The minimum requirements that must be met to satisfy European regulations are described in [Table 8](#).

Application	Category	Immunity level
All exposed surfaces of the radio equipment and ancillary equipment in a representative configuration of the end product.	Contact discharge	4 kV
	Air discharge	8 kV

Table 8: Minimum ESD immunity requirements based on EN 61000-4-2

Compliance with standard protection level specified in EN 61000-4-2 is achieved by including proper ESD protection in the production line and close to all areas that are accessible to the end user.

12 Labeling and ordering

The labels applied to M2-JODY-W2 cards include important product information.

Figure 11 shows the label applied to M2-JODY-W2 cards. Each of the given label references are described in Table 9.

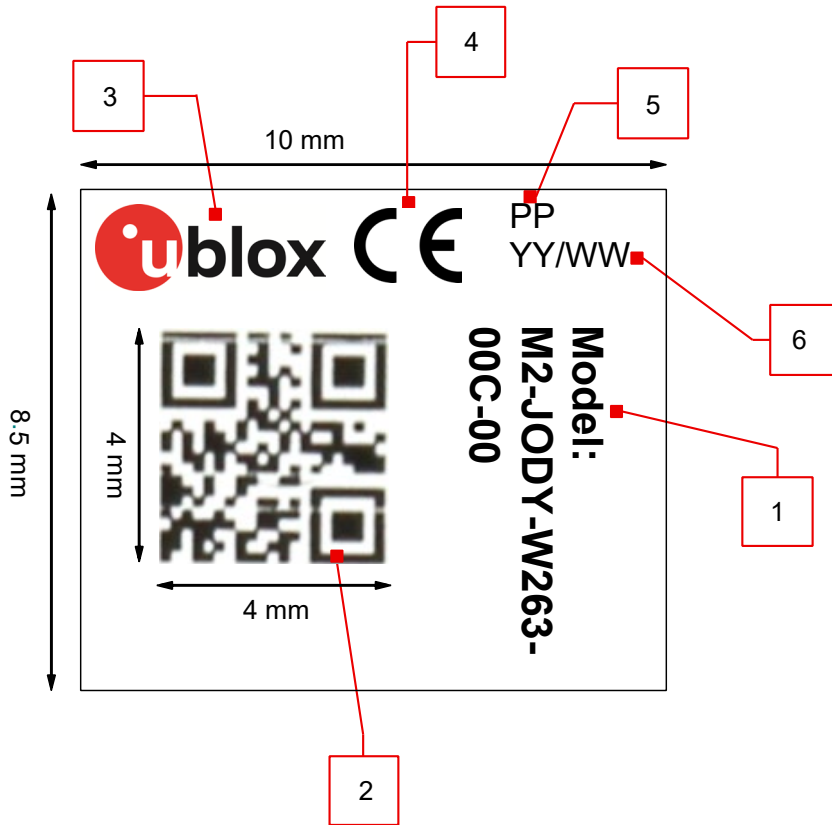

Figure 11. Product label format with dimensions

Reference	Description
1	Text in bold font: "Model:" type number with the product version
2	DataMatrix (product identifier, serial number, datacode) <ul style="list-style-type: none"> Product identifier: 3 digits defined by EMS Serial number Datacode: 4 digits
3	Company logo and trademark
4	Placeholder for CE marking (when certified)
5	Panel position number
6	Production date YY/WW (year/week)

Table 9. M2-JODY-W2 card label description

12.1 Ordering codes

Ordering Code	Product name	Product
M2-JODY-W263-00C	M2-JODY-W263	M.2 key E card (2230) with two antenna U.FL connectors (one for 2.4 GHz and 5 GHz 802.11ac and another for Bluetooth/Bluetooth Low Energy 5.2). Operational temperature -40 °C to +85 °C, standard grade module with NXP chipset 88W8987. Packaged in tray containing multiple M.2 cards.

Table 10: Product ordering codes

 Product changes affecting form, fit or function are documented by u-blox. Visit our website for a list of Product Change Notifications (PCNs).

Appendix

A Wi-Fi Tx output power limits

A.1. FCC/ISED regulatory domain

A.1.1. Wi-Fi Output power for 2.4 GHz band

Channel	Modulation	Channel bandwidth	Data rates	Maximum power setting
1 - 11	CCK and DSSS	20 MHz	1, 2, 5.5, 11 Mbps	12 dBm
1	OFDM	20 MHz	6, 9, 12, 18, 24, 36, 48, 54 Mbps	11 dBm
2 - 10	OFDM	20 MHz	6, 9, 12, 18, 24, 36, 48, 54 Mbps	16 dBm
11	OFDM	20 MHz	6, 9, 12, 18, 24, 36, 48, 54 Mbps	11 dBm
1	OFDM	20 MHz	HT20 MCS0-MCS7	11 dBm
2 - 10	OFDM	20 MHz	HT20 MCS0-MCS7	16 dBm
11	OFDM	20 MHz	HT20 MCS0-MCS7	11 dBm
3	OFDM	40 MHz	HT40 MCS0-MCS7	8 dBm
4	OFDM	40 MHz	HT40 MCS0-MCS7	9 dBm
5, 9	OFDM	40 MHz	HT40 MCS0-MCS7	10 dBm
6 - 8	OFDM	40 MHz	HT40 MCS0-MCS7	11 dBm

Table 11: FCC Wi-Fi power table for operation in the 2.4 GHz band

A.1.2. Wi-Fi output power for 5 GHz band

Channel	Modulation	Channel bandwidth	Data rates	Maximum power setting
36 - 64	OFDM	20 MHz	6, 9, 12, 18, 24, 36, 48, 54 Mbps	14 dBm
36 - 64	OFDM	20 MHz	HT20 MCS0-MCS7	14 dBm
36 - 64	OFDM	20 MHz	VHT20 MCS0-MCS8	14 dBm
38 - 62	OFDM	40 MHz	HT40 MCS0-MCS7	14 dBm
38 - 62	OFDM	40 MHz	VHT40 MCS0-MCS9	14 dBm
42, 58	OFDM	80 MHz	VHT80 MCS0-MCS9	12 dBm

Table 12: FCC Wi-Fi power table for operation in the 5 GHz U-NII-1 and U-NII-2A bands

Channel	Modulation	Channel bandwidth	Data rates	Maximum power setting
100 - 144	OFDM	20 MHz	6, 9, 12, 18, 24, 36, 48, 54 Mbps	14 dBm
100 - 144	OFDM	20 MHz	HT20 MCS0-MCS7	14 dBm
100 - 144	OFDM	20 MHz	VHT20 MCS0-MCS8	14 dBm
102	OFDM	40 MHz	HT40 MCS0-MCS7	14 dBm
102	OFDM	40 MHz	VHT40 MCS0-MCS9	14 dBm
110-142	OFDM	40 MHz	HT40 MCS0-MCS7	14 dBm
110-142	OFDM	40 MHz	VHT40 MCS0-MCS9	13 dBm
106 - 138	OFDM	80 MHz	VHT80 MCS0-MCS9	12 dBm

Table 13: FCC Wi-Fi power table for operation in the 5 GHz U-NII-2e band

Channel	Modulation	Channel bandwidth	Data rates	Maximum power setting
149 – 165	OFDM	20 MHz	6, 9, 12, 18, 24, 36, 48, 54 Mbps	15 dBm
149 – 165	OFDM	20 MHz	HT20 MCS0-MCS7	15 dBm
149 – 165	OFDM	20 MHz	VHT20 MCS0-MCS8	15 dBm
151 – 159	OFDM	40 MHz	HT40 MCS0-MCS7	13 dBm
151 – 159	OFDM	40 MHz	VHT40 MCS0-MCS9	13 dBm
155	OFDM	80 MHz	VHT80 MCS0-MCS9	13 dBm

Table 14: FCC Wi-Fi power table for operation in the 5 GHz U-NII-3 band

B Glossary

Abbreviation	Definition
BLE	Bluetooth Low Energy
BSP	Board Support Package
BT	Bluetooth
DNI	Do Not Insert
I2S	Inter-IC-Sound
IC	Integrated Circuit
PCIe	Peripheral Component Interconnect Express
PCM	Pulse Code Modulation
SDIO	Secure Digital Input Output
TBD	To be defined / determined
UART	Universal Asynchronous Receiver-Transmitter
USB	Universal Serial Bus
VIO	Input /Output Voltage
U.FL	Low-profile SMT coaxial connector

Table 15: Explanation of the abbreviations and terms used

Related documentation

- [1] JODY-W2 series data sheet, [UBX-18017567](#)
- [2] JODY-W2 system integration manual, [UBX-18068879](#)
- [3] Product packaging reference guide, [UBX-14001652](#)
- [4] Marvell 88W8987 datasheet, Doc. No. MV-S110948-00, Rev. E August 20, 2019, 2.00
- [5] PCI Express M.2 Specification Revision 4.0, Version 1.0, November 5, 2020
- [6] Wi-Fi/Bluetooth M.2 Key E Pinout Definition – NXP Application Note AN13049, Rev.1, November 12, 2020
- [7] Hirose Electric Co. LTD - U.FL Series Catalog, August 2021
- [8] Hirose Electric Co. LTD - U.FL Series Specification Sheet, June 19, 2020
- [9] u-blox Limited Use License Agreement (LULA-M)

 For product change notifications and regular updates of u-blox documentation, register on our website, www.u-blox.com.

Revision history

Revision	Date	Name	Comments
R01	9-Apr-2021	gima	Initial release
R02	17-Feb-2022	gmet	Updated figures and tables with latest product information. Added Software , Approvals , Product handling , and Labeling and ordering chapters.
R03	16-Nov-2022	gmet	Added Electrical specifications and Appendix A . Updated Approvals . Updated product name, type number, and product status in Document information . Revised disclosure restriction class.
R04	23-Nov-2022	ctur	Revised disclosure restriction class for public distribution.
R05	03-May-2023	gmet	Updated contact information and Electrical specifications .
R06	20-Mar-2024	iban, gmet	Updated sections Pin description , Antenna connectors , Test points and Approvals .

Contact

u-blox AG

Address: Zürcherstrasse 68
8800 Thalwil
Switzerland

For further support and contact information, visit us at www.u-blox.com/support.

X-ON Electronics

Largest Supplier of Electrical and Electronic Components

Click to view similar products for [Multiprotocol Modules](#) category:

Click to view products by [U-Blox](#) manufacturer:

Other Similar products are found below :

[9260.NGWG.NV 958867](#) [AX210.NGWG.NV](#) [BM833](#) [ESP32-C3-MINI-1U-H4](#) [ESP32-WROOM-32U-16MB](#) [ESP32-WROOM-32UE](#)
[ESP32-WROOM-32D-H4](#) [ESP32-WROOM-32U-H4](#) [ESP32-PICO-MINI-02U-N8R2](#) [ESP32-C6-WROOM-1-N4](#) [ESP32-C6-WROOM-1U-N4](#)
[ESP32-C6-WROOM-1-N8](#) [BE200.NGWG.NV](#) [BE200.NGWG](#) [BE202.NGWG.NV](#) [BE200.NGWG.NVX](#) [AX411.NGWG.NV](#) [AX210.D2WG](#)
[AX210.NGWG.NVX](#) [AX211.NGWG](#) [EC200UEUAA-N05-TA0AA](#) [SC20ELSATEA-8GB-UGAD](#) [SG560DEUPA-U61-TA0AA](#)
[AX211.NGWG.NV](#) [ISM43340-M4G-L44-10CF-C6.2.1.11](#) [KG100SABMD](#) [BC40P](#) [S007-PIN254](#) [S007-PIN127](#) [ESP32-C3-12F](#)
[FC41DAHMD](#) [EWM-W179M201E](#) [ESP32-C6-WROOM-1U-N8](#) [ATWILC3000-MR110CA](#) [RS9113-NBZ-D5W](#) [ATWINC3400-](#)
[MR210UA122](#) [ESP32-WROOM-32](#) [AMPAK AP12356 WIFI/BT KIT](#) [AIW-154BN](#) [AIW-165BN](#) [AIW-166K1](#) [AIW-166K2](#) [AIW-166K3](#)
[AIW-166K4](#) [AIW-355 DQ-N01](#) [AIW-355 DQ-C01](#) [EWM-W159M201E](#) [EWM-W192K1](#) [EWM-W192K2](#) [W106C](#)