



MAX-F10S

Standard precision GNSS module

Professional grade

Data sheet



Abstract

This data sheet describes the MAX-F10S module, an L1/L5 dual-band GNSS receiver for meter-level accuracy in urban environment.

Note! GPS L5 signals are pre-operational and not used by default. Refer to the Overview section for more information.

www.u-blox.com

UBXDOC-963802114-12732 - R02
C1-Public



Document information

Title	MAX-F10S	
Subtitle	Standard precision GNSS module	
Document type	Data sheet	
Document number	UBXDOC-963802114-12732	
Revision and date	R02	28-Aug-2024
Disclosure restriction	C1-Public	

Product status	Corresponding content status	
Functional sample	Draft	For functional testing. Revised and supplementary data will be published later.
In development / prototype	Objective specification	Target values. Revised and supplementary data will be published later.
Engineering sample	Advance information	Data based on early testing. Revised and supplementary data will be published later.
Initial production	Early production information	Data from product verification. Revised and supplementary data may be published later.
Mass production / End of life	Production information	Document contains the final product specification.

This document applies to the following products:

Product name	Type number	FW version	IN/PCN reference	Product status
MAX-F10S	MAX-F10S-00B-00	ROM SPG 6.00	UBXDOC-963802114-12967	Initial production

u-blox or third parties may hold intellectual property rights in the products, names, logos and designs included in this document. Copying, reproduction, or modification of this document or any part thereof is only permitted with the express written permission of u-blox. Disclosure to third parties is permitted for clearly public documents only.

The information contained herein is provided "as is" and u-blox assumes no liability for its use. No warranty, either express or implied, is given, including but not limited to, with respect to the accuracy, correctness, reliability and fitness for a particular purpose of the information. This document may be revised by u-blox at any time without notice. For the most recent documents, visit www.u-blox.com.

Copyright © 2024, u-blox AG.

Contents

1 Functional description.....	4
1.1 Overview.....	4
1.2 Performance.....	4
1.3 Supported GNSS constellations.....	5
1.4 Supported protocols.....	6
1.5 Firmware features.....	6
2 Block diagram.....	7
3 Pin definition.....	8
3.1 Pin assignment.....	8
3.2 Pin state.....	9
4 Electrical specifications.....	10
4.1 Absolute maximum ratings.....	10
4.2 Operating conditions.....	10
4.3 Indicative power requirements.....	11
5 Communication interfaces.....	13
5.1 UART.....	13
5.2 I2C.....	13
5.3 Default interface settings.....	15
6 Mechanical specifications.....	16
7 Qualifications and approvals.....	17
8 Product handling.....	18
8.1 Packaging.....	18
8.1.1 Reels.....	18
8.1.2 Tapes.....	18
8.2 Soldering.....	19
9 Labeling and ordering information.....	20
9.1 Product labeling.....	20
9.2 Explanation of product codes.....	20
9.3 Ordering codes.....	20
Related documents.....	22
Revision history.....	23

1 Functional description

1.1 Overview

MAX-F10S is built on the u-blox F10 dual-band GNSS technology using L1 and L5 band signals. The proprietary dual-band multipath mitigation technology enables the u-blox F10 to use the best signals from the L1 and L5 bands providing a solid meter-level position accuracy in urban environment.

- ⚠ At the time of writing, the GPS L5 signals remain pre-operational and are set as unhealthy until sufficient monitoring capability is established. This is an operational issue concerning the satellites / space segment and not a limitation of u-blox products.
- ⚠ Due to the pre-operational status, the GPS L5 signals are not used for the navigation solution by default. However, it is possible to evaluate the GPS L5 signals before they become fully operational by changing the receiver configuration to override the GPS L5 health status. Refer to the Integration manual [1] for details.

1.2 Performance

Parameter	Specification	Value
Receiver type		u-blox F10 dual-band receiver
Accuracy of time pulse signal	RMS	30 ns
	99%	60 ns
Frequency of time pulse signal		Default 1PPS (0.25 Hz to 10 MHz configurable)
Operational limits ¹	Dynamics	≤ 4 g
	Altitude	80,000 m
	Velocity	500 m/s
Velocity accuracy ²		0.05 m/s
Dynamic heading accuracy ²		0.3 deg

Table 1: MAX-F10S specifications

Table 2 shows typical performance values in multi-GNSS configurations³. SBAS is enabled in all measurements.

Parameter	GPS+GAL +BDS (Default)	GPS+BDS	GPS+GAL	GPS+NavIC	Unit
Max navigation update rate ⁴	10	10	10	10	Hz
Position accuracy (CEP) ⁵	1	1	1	1	m
Time To First Fix (TTFF) ⁶	Cold start	28	28	27	s
	Hot start	1	1	1	s
	AssistNow Online ⁷	1	1	1	s

¹ Assuming Airborne 4 g platform.

² 50% at 30 m/s for dynamic operation.

³ The GPS L5 signal health status is ignored. Configuration required.

⁴ Minimum 98% fix rate under typical conditions.

⁵ CEP, 50%, 24 hours static, -130 dBm, > 6 SVs for each GNSS system.

⁶ Commanded starts. All satellites signals at -130 dBm. Measured at room temperature.

⁷ Depends on the speed and latency of the aiding data connection, commanded starts.

Parameter		GPS+GAL +BDS (Default)	GPS+BDS	GPS+GAL	GPS+NavIC	Unit
Sensitivity ¹⁰	AssistNow Offline ⁸	3	3	2	2	s
	AssistNow Autonomous ⁹	4	4	4	4	s
	Tracking and navigation	-167	-167	-167	-167	dBm
	Reacquisition	-159	-159	-159	-159	dBm
	Cold Start	-148	-148	-148	-148	dBm
	Hot start	-159	-159	-159	-159	dBm

Table 2: MAX-F10S typical performance in multi-GNSS configurations

Table 3 shows typical performance values in single-GNSS configurations³. SBAS is enabled in all measurements.

Parameter		GPS	BDS	Unit
Max navigation update rate ⁴		20	20	Hz
Position accuracy (CEP) ⁵		1.5	1	m
Time To First Fix (TTFF) ⁶	Cold start	27	42	s
	Hot start	1	1	s
	AssistNow Online ⁷	1	N/A	s
Sensitivity ¹⁰	Tracking and navigation	-167	-163	dBm
	Reacquisition	-159	-156	dBm
	Cold Start	-148	-137	dBm
	Hot start	-159	-157	dBm

Table 3: MAX-F10S typical performance in single-GNSS configurations

1.3 Supported GNSS constellations

MAX-F10S is a concurrent GNSS receiver that can receive and track multiple GNSS systems. The dual-band RF front-end architecture enables concurrent reception of multiple dual frequency GNSS constellations. The receiver can be configured for a subset of GNSS constellations to achieve lower power consumption.

The default configuration on MAX-F10S is concurrent reception of GPS, Galileo and BeiDou with SBAS enabled.

The following GNSS and their signals are supported:

System	Signals
GPS / QZSS	L1C/A (1575.42 MHz), L5 (1176.450 MHz)
Galileo	E1-B/C (1575.42 MHz), E5a (1176.450 MHz)
BeiDou	B1C (1575.42 MHz), B2a (1176.450 MHz)
NavIC	SPS-L5 (1176.450 MHz)

Table 4: Supported GNSS and signals on MAX-F10S

The following GNSS assistance services are supported:

⁸ Using seven days old AssistNow Offline data. External memory may be required.

⁹ Using two days old orbital predicted data. External memory may be required.

¹⁰ Demonstrated with a good external LNA. Measured at room temperature.

Service	Support
AssistNow™ Online	GPS L1C/A, Galileo E1, QZSS L1C/A
AssistNow™ Offline	GPS L1C/A, Galileo E1, QZSS L1C/A
AssistNow™ Autonomous	GPS L1C/A, Galileo E1, QZSS L1C/A

Table 5: Supported Assisted GNSS (A-GNSS) services

The following augmentation systems are supported:

System	Support
SBAS ¹¹	EGNOS, GAGAN, MSAS, WAAS, and BDSBAS
QZSS	L1S (SLAS), L1Sb (SBAS)

Table 6: Supported augmentation systems

The augmentation systems SBAS and QZSS can be enabled only if GPS operation is also enabled.

1.4 Supported protocols

MAX-F10S supports the following interface protocols:

Protocol	Type
UBX	Input/output, binary, u-blox proprietary
NMEA versions 2.1, 2.3, 4.0, 4.10 and 4.11 (default)	Input/output, ASCII

Table 7: Supported protocols

1.5 Firmware features

Feature	Description
Antenna supervisor ¹²	Antenna supervisor for active antenna control and short detection
Assisted GNSS	AssistNow Online, AssistNow Offline and AssistNow Autonomous
Backup modes	Hardware backup mode and software standby mode
Protection level	Real-time position accuracy estimate with 95% confidence level ¹³
Galileo return link messages	Galileo search and rescue (SAR) return link messages (RLM) via Galileo satellite signal
Odometer	Measure traveled distance with support for different user profiles

Table 8: Firmware features

Feature	Description
Anti-jamming	RF interference and jamming detection and reporting
Anti-spoofing	Spoofing detection and reporting
Configuration lockdown	Receiver configuration can be locked by command
Message integrity	All messages can be cryptographically signed
Secure boot	Only signed firmware images are executed

Table 9: Security features

¹¹ Ionospheric correction service is the only SBAS service supported by MAX-F10S

¹² External components required, some pins need to be reconfigured.

¹³ Verified for automotive environment only.

2 Block diagram

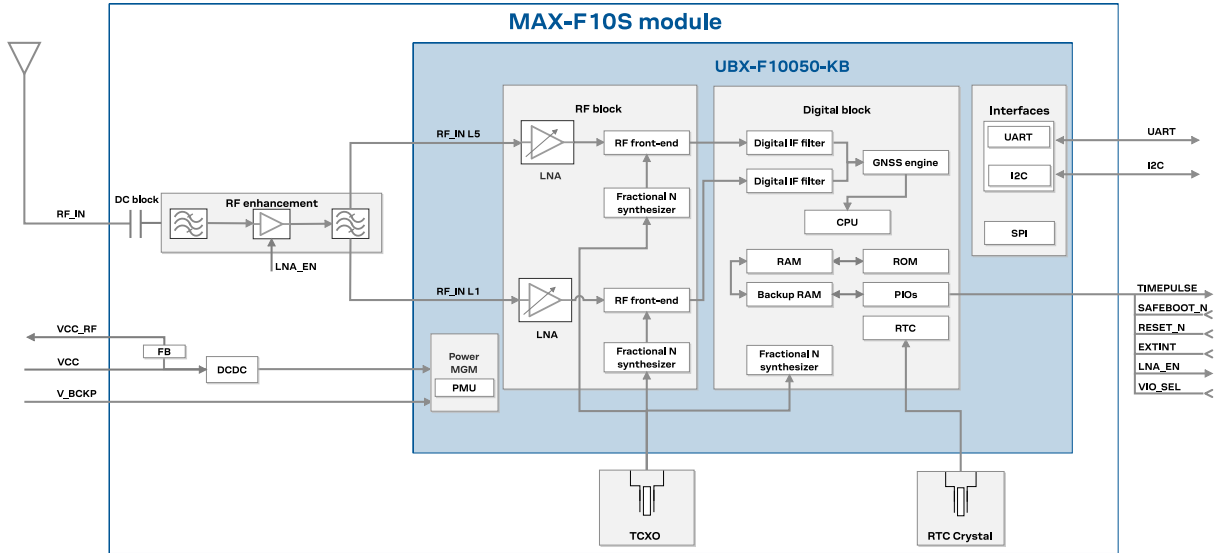

Figure 1: MAX-F10S block diagram

3 Pin definition

3.1 Pin assignment

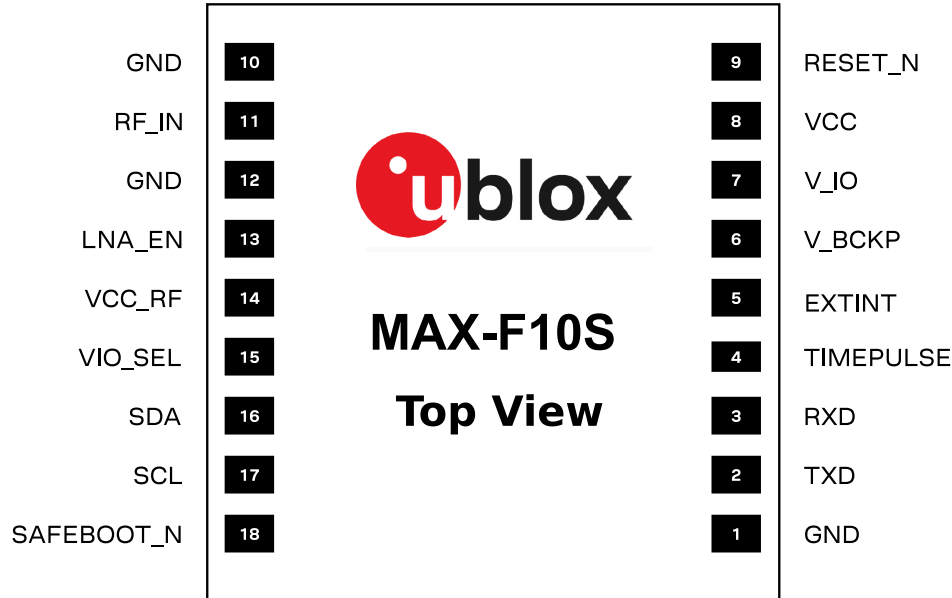

Figure 2: MAX-F10S pin assignment

Pin no.	Name	PIO no.	I/O	Description
1	GND	-	-	Connect to GND
2	TXD	1	O	UART TX. Leave open if not used.
3	RXD	0	I	UART RX. Leave open if not used.
4	TIMEPULSE	4	O	Time pulse signal (shared with SAFEBOOT_N pin) ¹⁴
5	EXTINT	5	I	External interrupt. Leave open if not used.
6	V_BCKP	-	I	Backup voltage supply
7	V_IO	-	I	IO voltage supply
8	VCC	-	I	Main voltage supply
9	RESET_N	-	I	System reset (active low). Has to be low for at least 1 ms to trigger a reset.
10	GND	-	-	Connect to GND
11	RF_IN	-	I	GNSS signal input
12	GND	-	-	Connect to GND
13	LNA_EN	-	O	On/Off external LNA or active antenna
14	VCC_RF	-	O	Output voltage RF section
15	VIO_SEL	-	I	Voltage selector for V_IO supply. Connect to GND for 1.8 V supply, or leave open for 3.3 V supply.
16	SDA	2	I/O	I2C data. Leave open if not used.
17	SCL	3	I	I2C clock. Leave open if not used.
18	SAFEBOOT_N	-	I	Safeboot mode (active low). Leave open if not used. ¹⁴

Table 10: MAX-F10S pin assignment

¹⁴ The receiver enters safeboot mode if this pin is low at start up. The SAFEBOOT_N pin is internally connected to TIMEPULSE pin through a 1 kΩ series resistor.

3.2 Pin state

Table 11 defines the state of the PIOs and RESET_N pins in different modes. The functions of the PIOs are as defined in the default configuration.

PIO no.	Pin no.	Default function	Continuous mode	Software standby mode	Safe boot mode
0	3	RXD	Input pull-up	Input pull-up	Input pull-up
1	2	TXD	Output	Input pull-up	Output
2	16	SDA	Input pull-up	Input pull-up	Input pull-up
3	17	SCL	Input pull-up	Input pull-up	Input pull-up
4 ¹⁴	18	SAFEBOOT_N	Output	Input pull-up	Output (low)
	4	TIMEPULSE	Output	Input pull-up	Output (low)
5	5	EXTINT	Input pull-up	Input pull-up	Input pull-up
7	13	LNA_EN	Output (high)	Input pull-down	Input pull-up
-	9	RESET_N	Input pull-up	Input pull-up	Input pull-up

Table 11: Pin state





In reset mode (RESET_N = low), all PIOs are configured as input pull-up.



In hardware backup mode (VCC = 0 V and V_IO = 0 V), PIOs must not be driven.

4 Electrical specifications

4.1 Absolute maximum ratings

-  CAUTION. Risk of device damage. Exceeding the absolute maximum ratings may affect the lifetime and reliability of the device or permanently damage it. Do not exceed the absolute maximum ratings.
-  This product is not protected against overvoltage or reversed voltages. Use appropriate protection to avoid device damage from voltage spikes exceeding the specified boundaries.

Symbol	Parameter	Min	Max	Unit
VCC	Main supply voltage	-0.3	3.6	V
V _{IO}	IO supply voltage, V _{IO_SEL} = GND.	-0.3	VCC + 0.3 (max 1.98)	V
	IO supply voltage, V _{IO_SEL} = open.	-0.3	VCC + 0.3 (max 3.6)	V
	Voltage ramp on V _{IO} ¹⁵	25	35000	μs/V
V _{BCKP}	Backup supply voltage	-0.3	3.6	V
V _{PIO}	Input voltage on RESET_N and digital pins V _{IO_SEL} = GND	-0.3	V _{IO} + 0.3 (max 1.98)	V
	Input voltage on RESET_N and digital pins V _{IO_SEL} = open.	-0.3	V _{IO} + 0.3 (max 3.6)	V
I _{PIO}	Max source / sink current, digital pins ¹⁶	-10	10	mA
ICC _{RF}	Max source current, VCC _{RF}		200	mA
V _{DC_{rfin}}	DC voltage at RF_IN	-5.5	+5.5	V
P _{rfin}	RF input power at RF_IN ¹⁷		0	dBm
T _{amb}	Ambient temperature	-40	+85	°C
T _s	Storage temperature	-40	+85	°C

Table 12: Absolute maximum ratings

4.2 Operating conditions

Table 13 shows the general operating conditions. Table 14 shows the electrical parameters for digital I/O.

 The V_{IO} voltage range is selected with the V_{IO_SEL} pin.

-  For designs with 1.8 V supply at V_{IO} and V_{BCKP} supplied, switch off V_{IO} supply 100 ms before VCC when transitioning to hardware backup mode. Alternatively, put the receiver to software standby mode by sending UBX-RXM-PMREQ message before switching off V_{IO} and VCC. For designs with 3 V supplies, both supplies can be switched off simultaneously or ensure that V_{IO} is switched off before VCC.

Symbol	Parameter	Min	Typical	Max	Unit
VCC	Main supply voltage	1.76	1.8, 3.3	3.6	V

¹⁵ Exceeding the voltage ramp speed may permanently damage the device.

¹⁶ The SAFEBOOT_N pin has an internal 1 kΩ series resistor.

¹⁷ Test conditions: source impedance = 50 Ω, continuous wave.

Symbol	Parameter	Min	Typical	Max	Unit
V _{IO}	IO supply voltage, V _{IO_SEL} = GND	1.76	1.8	VCC (max 1.98)	V
	IO supply voltage, V _{IO_SEL} = open	2.7	3.3	VCC (max 3.6)	V
V _{BCKP}	Supply voltage, backup domain	1.65		3.6	V
V _{IOSWITCH}	V _{IO} voltage threshold to switch an internal supply for the backup domain from V _{IO} to V _{BCKP}		1.45		V
VCC _{RF}	VCC _{RF} output voltage		VCC - 0.1		V
ICC _{RF}	VCC _{RF} output current			50	mA
Z _{in} ¹⁸	Input impedance at RF_IN		50		Ω
NF _{tot}	Receiver chain noise figure (L1)		3.5		dB
	Receiver chain noise figure (L5)		3		dB
Ext_gain ¹⁹	External gain at RF_IN, low gain mode			30	dB
	External gain at RF_IN, bypass mode	10	25	40	dB
T _{opr}	Operating temperature	-40		+85	°C

Table 13: General operating conditions

Symbol	Parameter	Min	Typical	Max	Unit
I _{leak}	Leakage current input pins ²⁰		25		nA
V _{in}	Input pin voltage range	0		V _{IO}	V
V _{il}	Low-level input voltage			0.63	V
V _{ih}	High-level input voltage	0.68 x V _{IO}			V
V _{ol}	Low-level output voltage, I _{out} = -2 mA ²¹			0.4	V
V _{oh}	High-level output voltage, I _{out} = 2 mA ²¹	V _{IO} - 0.4			V
R _{pu,IO}	Pull-up resistance, Digital IO ²² . V _{IO_SEL} = GND	6	17	72	kΩ
R _{pu,IO}	Pull-up resistance, Digital IO ²² . V _{IO_SEL} = open	8	18	40	kΩ
R _{pd,IO}	Pull-down resistance, Digital IO	21	80	180	kΩ
R _{pu,SAFEBOOT_N}	Pull-up resistance, SAFEBOOT_N ²³	6	17	72	kΩ
R _{pu,RESET_N}	Pull-up resistance, RESET_N	7	10	13	kΩ

Table 14: Digital IO

4.3 Indicative power requirements

This section provides examples of typical current requirements. They are characterized on samples using a cold start command. The actual power requirements may vary depending on the firmware version used, the external circuitry, the number of satellites tracked, the signal strength, the type and time of start, duration, internal LNA gain mode, and the test conditions.

All values in [Table 15](#) and [Table 17](#) have been measured at 25 °C ambient temperature with the default configuration unless otherwise stated. SBAS is active in all measurements.

¹⁸ The RF_IN input integrates a built-in DC block.

¹⁹ The internal LNA gain is configurable.

²⁰ V_{in} = V_{IO}, at room temperature.

²¹ TIMEPULSE (PIO4) has 4 mA current drive/sink capability.

²² TXD, RXD, TIMEPULSE, EXTINT, SCL, SDA, and LNA_EN.

²³ The SAFEBOOT_N pin has an additional 1 kΩ series resistor.

Table 15 shows indicative current consumption for VCC with a 3.0 V supply.

Symbol (Parameter)	Conditions	GPS+GAL +BDS (Default)	GPS+BDS	GPS+GAL	GPS +NavIC	GPS	BDS	Unit
I_{VCC}^{24} (VCC current)	Acquisition ²⁵	21	21	17	16	15	18	mA
	Tracking	16	16	15	14	13	14	mA
$I_{V_{IO}}^{26}$ (V_IO current)	Acquisition and Tracking	3	3	3	3	3	3	mA

Table 15: Typical currents for 3.0 V supply at VCC and V_IO

Symbol (Parameter)	Conditions	GPS+GAL +BDS (Default)	GPS+BDS	GPS+GAL	GPS +NavIC	GPS	BDS	Unit
I_{VCC}^{24} (VCC current)	Acquisition ²⁵	31	31	25	22	21	26	mA
	Tracking	23	23	21	19	18	20	mA
$I_{V_{IO}}^{26}$ (V_IO current)	Acquisition and Tracking	3	3	3	3	3	3	mA

Table 16: Typical currents for 1.8 V supply at VCC and V_IO



The inrush current can go up to 100 mA at startup. Ensure that the external power supply is able to deliver up to 100 mA.

Table 17 shows current consumption for backup modes.

Symbol	Parameter	Conditions	Typical	Unit
$I_{V_{BCKP}}^{27}$	Total current in hardware backup mode	$V_{BCKP} = 3.3\text{ V}; VCC = V_{IO} = 0\text{ V}$	28	μA
$I_{V_{IO}}$	V_IO current in software standby mode	V_{IO} (low range) = 1.8 V	37	μA
		V_{IO} (high range) = 3.3 V	46	μA
I_{VCC}	VCC current in software standby mode	$VCC = 3.3\text{ V}$	120	nA

Table 17: Backup currents



Extreme operating temperatures can significantly impact the specified values. If an application operates near the min or max temperature limits, ensure the specified values are not exceeded.

²⁴ 1 Hz navigation update rate. Simulated signals using power levels of -130 dBm.

²⁵ Average current from start-up until the first fix.

²⁶ Same current with voltage at $V_{IO} = 1.8\text{ V}$ and 3.3 V .

²⁷ $I_{V_{BCKP}}$ current in normal operation ($V_{BCKP} = 3.3\text{ V}$) is $\sim 3\ \mu\text{A}$.

5 Communication interfaces

The receiver supports communication over the UART only.

All the inputs have an internal pull-up resistor in normal operation and can be left open if not used. The voltage level at the PIO pins is related to the VCC supply voltage.

5.1 UART

The UART interface supports configurable baud rates. Hardware flow control is not supported. UART specifications are described in [Table 18](#).

Symbol	Parameter	Min	Max	Unit
R_u	Baud rate	9600	921600	bit/s
Δ_{Tx}	Tx baud rate accuracy	-1%	+1%	-
Δ_{Rx}	Rx baud rate tolerance	-2.5%	+2.5%	-

Table 18: UART specifications

5.2 I2C

An I2C interface is available for communication with an external host CPU in the I2C Fast-mode. Backwards compatibility with the Standard-mode I2C bus operation is not supported. The interface can be operated only in the peripheral mode with a maximum clock frequency of 320 kHz²⁸.

The interface can make use of clock stretching by holding the SCL line LOW to pause a transaction. In this case, the bit transfer rate is reduced. The maximum clock stretching time is 20 ms.

²⁸ External pull-up resistors may be needed to achieve 320 kbit/s communication speed, as the internal pull-up resistance can be very large.

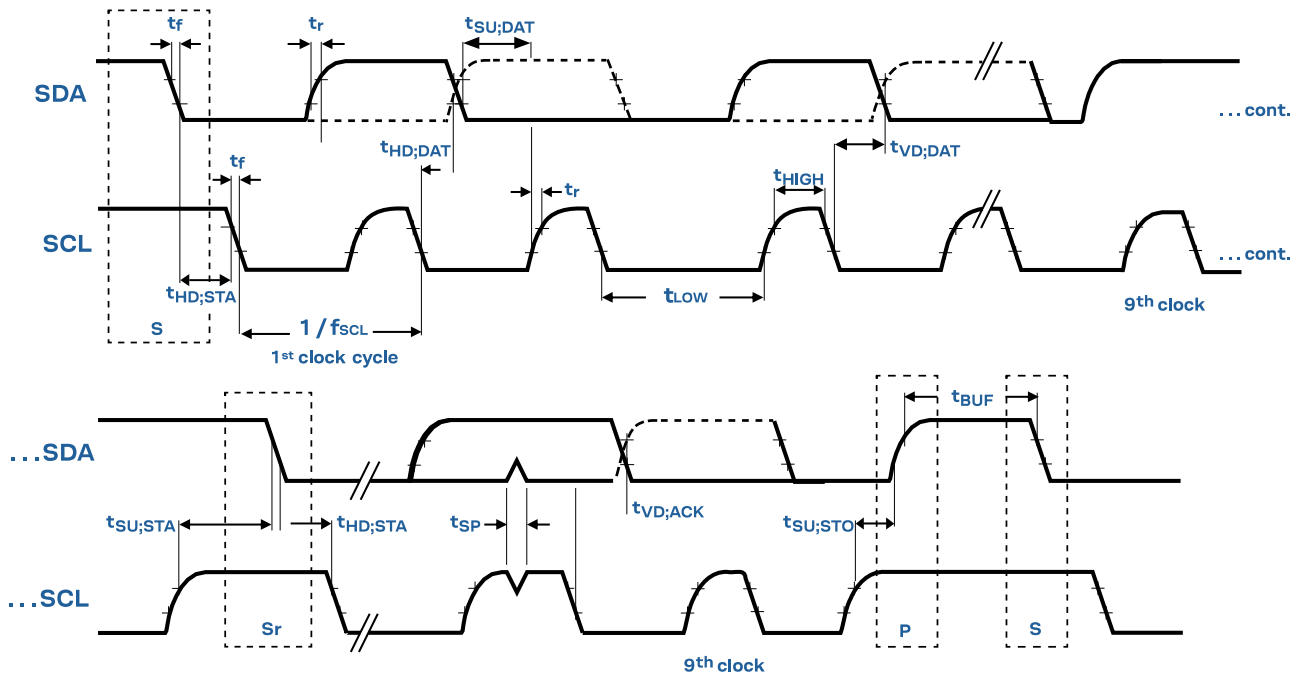

$$V_{IL} = 0.3 V_{DD}$$

$$V_{IH} = 0.7 V_{DD}$$

Figure 3: I2C peripheral specification

Symbol	Parameter	I2C Fast-mode		Unit
		Min	Max	
f_{SCL}	SCL clock frequency	0	320	kHz
$t_{HD;STA}$	Hold time (repeated) START condition	0.6	-	μs
t_{LOW}	Low period of the SCL clock	1.3	-	μs
t_{HIGH}	High period of the SCL clock	0.6	-	μs
$t_{SU;STA}$	Setup time for a repeated START condition	0.6	-	μs
$t_{HD;DAT}$	Data hold time	0 ²⁹	_30	μs
$t_{SU;DAT}$	Data setup time	100	-	ns
t_r	Rise time of both SDA and SCL signals	-	300 (for C = 400pF)	ns
t_f	Fall time of both SDA and SCL signals	-	300 (for C = 400pF)	ns
$t_{SU;STO}$	Setup time for STOP condition	0.6	-	μs
t_{BUF}	Bus-free time between a STOP and START condition	1.3	-	μs
$t_{VD;DAT}$	Data valid time	-	0.9 ³⁰	μs
$t_{VD;ACK}$	Data valid acknowledge time	-	0.9 ³⁰	μs
V_{nL}	Noise margin at the low level	0.1 V_{IO}	-	V

²⁹ External device must provide a hold time of at least one transition time (max 300 ns) for the SDA signal (with respect to the min V_{ih} of the SCL signal) to bridge the undefined region of the falling edge of SCL.

³⁰ The maximum $t_{HD;DAT}$ must be less than the maximum $t_{VD;DAT}$ or $t_{VD;ACK}$ with a maximum of 0.9 μs by a transition time. This maximum must only be met if the device does not stretch the LOW period (t_{LOW}) of the SCL signal. If the clock stretches the SCL, the data must be valid by the set-up time before it releases the clock.

Symbol	Parameter	I2C Fast-mode		Unit
		Min	Max	
V _{nH}	Noise margin at the high level	0.2 V _{IO}	-	V

Table 19: MAX-F10S I2C peripheral timing and specifications

5.3 Default interface settings

Interface	Settings
UART	<ul style="list-style-type: none"> 9600 baud, 8 bits, no parity bit, 1 stop bit. Input messages: NMEA and UBX. Output messages: NMEA GGA, GLL, GSA, GSV³¹, RMC, VTG and TXT.
I2C	<ul style="list-style-type: none"> 7-bit I2C address (0x42). Input messages: NMEA and UBX. Output messages: NMEA GGA, GLL, GSA, GSV³¹, RMC, VTG and TXT.

Table 20: Default interface settings

³¹ In the default configuration, the NMEA-GSV messages are sent at 5-second intervals to avoid overflow in the TX buffer.

6 Mechanical specifications

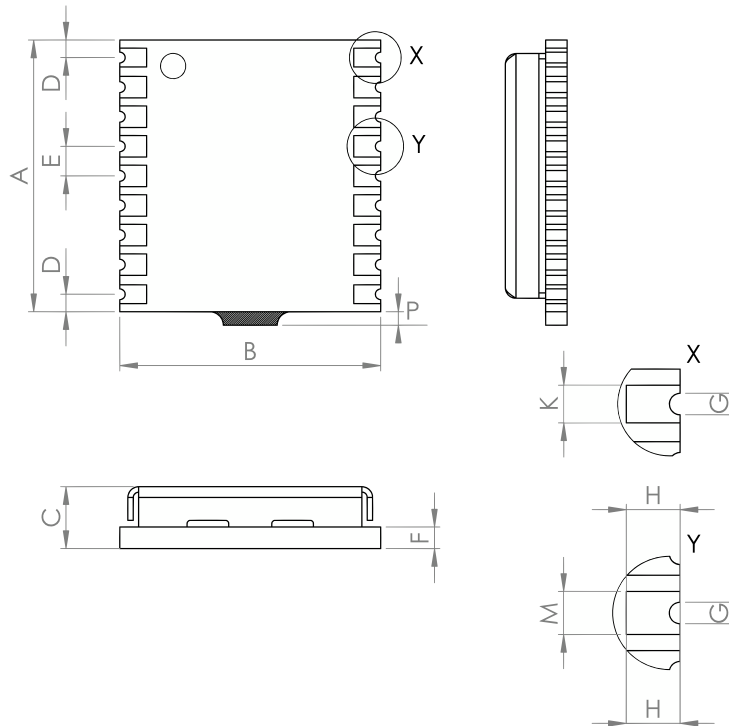





Figure 4: MAX-F10S mechanical drawing

Symbol	Min (mm)	Typical (mm)	Max (mm)
A	10.0	10.1	10.7
B	9.6	9.7	9.8
C	2.2	2.5	2.7
D	0.55	0.65	0.95
E	1.0	1.1	1.2
F	-	0.76	-
G	0.3	0.4	0.5
H	0.9	1.0	1.1
K	0.6	0.7	0.8
M	0.7	0.8	0.9
P	0.0	0.3	0.6
Weight		0.5 g	

Table 21: MAX-F10S mechanical dimensions

-  The mechanical picture of the de-paneling residual tab (P) is an approximate representation, shape and position may vary.
-  Take the size of the de-paneling residual tabs into account when designing the component keepout area.
-  The width (K) applies to all four corner pins.
-  The pitch (E) applies to all pins.

7 Qualifications and approvals

Type	Description
Quality and reliability	
Product qualification	Qualified according to u-blox qualification policy, based on a subset of AEC-Q104
Manufacturing	Manufactured at ISO/TS 16949 certified sites
Environmental	
RoHS compliance	Yes
Moisture sensitivity level (MSL) ^{32, 33}	4
Type approvals	
European RED certification (CE)	Declaration of Conformity (DoC) is available on the u-blox website .
UK conformity assessment (UKCA)	Yes

Table 22: Qualifications and approvals

³² For MSL standard see IPC/JEDEC J-STD-020 and J-STD-033 [5].

³³ For more information regarding moisture sensitivity levels, labeling, storage, and drying, see the Product packaging reference guide [4].

8 Product handling

8.1 Packaging

The MAX-F10S modules are delivered as hermetically sealed, reeled tapes to enable efficient production, production lot set-up and tear-down. For more information, see the Product packaging reference guide [4].

8.1.1 Reels

MAX-F10S modules are deliverable in quantities of 500 pieces on a reel. They are shipped on reel type B, as specified in the Product packaging reference guide [4].

8.1.2 Tapes

Figure 5 shows the feed direction and illustrates the orientation of the components on the tape.

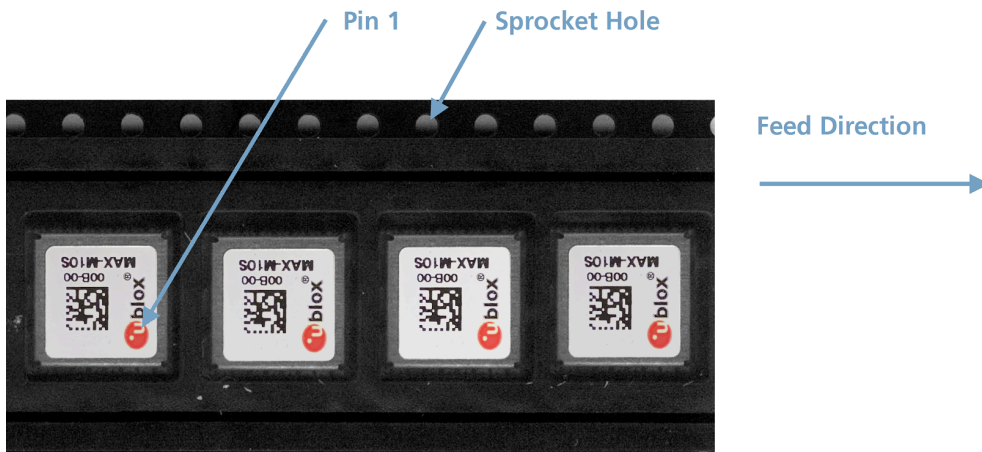
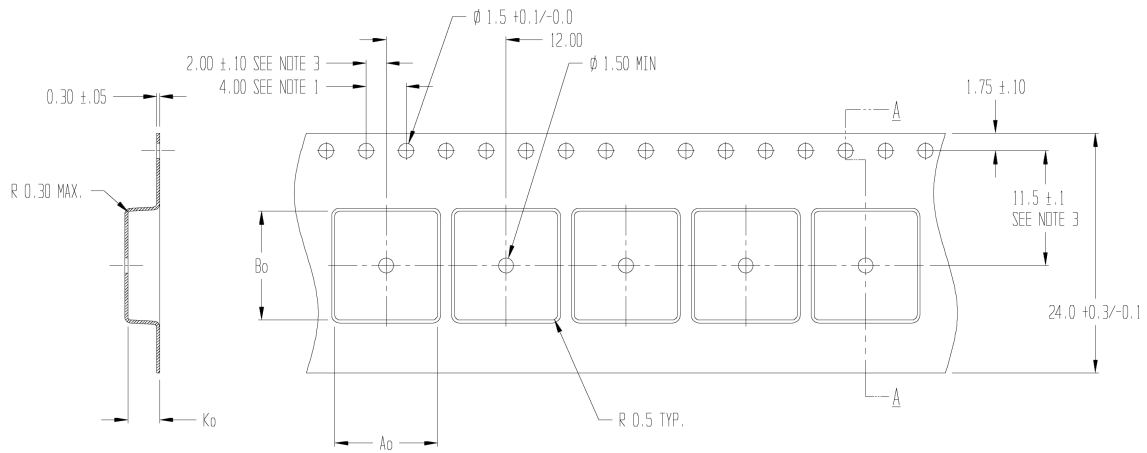

Figure 5: Orientation of the components on the tape

The feed direction into the pick and place pick-up is from the reel (located on the left of the figure) towards right, and the tape is fed to the right.

The dimensions of the tape are specified in Figure 6 (measurements in mm).



SECTION A - A

$A_0 = 10.30$
 $B_0 = 10.90$
 $K_0 = 3.20$

Measurements in mm.

Tolerances unless noted: 1Pl ± 0.2 2Pl ± 0.10

Notes:

1. 10 sprocket hole pitch cumulative tolerance ± 0.2
2. Pocket position relative to sprocket hole measured as true position of pocket, not pocket hole.
3. A_0 and B_0 are calculated on a plane at a distance "R" above the bottom of the pocket.

Figure 6: Tape dimensions (mm)

8.2 Soldering

Reflow soldering is described in the IPC/JEDEC J-STD-020 standard [5].

9 Labeling and ordering information

This section provides information about product labeling and ordering.

9.1 Product labeling

The labeling of MAX-F10S package provides product information and revision information. For more information, contact u-blox sales.

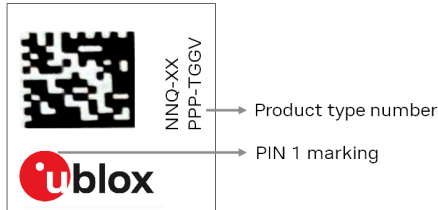

Figure 7: MAX-F10S label

The parts of the product code are explained in [Table 23](#)

Code	Meaning	Example
PPP	Product family	MAX
TGG	Platform	F10 = u-blox F10
V	Variant	S = Standard precision, ROM, TCXO, LNA, and SAW filter
NN	Option	00, 01, 02, ...
Q	Quality grade	A = Automotive, B = Professional
XX	Product detail	Describes hardware and firmware versions

Table 23: Part identification code

9.2 Explanation of product codes

Three product code formats are used in the product label. The product name is used in documentation such as this data sheet and identifies all u-blox products, independent of packaging and quality grade. The ordering code includes options and quality, while the type number includes the hardware and firmware versions.

[Table 24](#) describes the three different product code formats used in the MAX-F10S module.

Format	Structure	Product code
Product name	PPP-TGGV	MAX-F10S
Ordering code	PPP-TGGV-NNQ	MAX-F10S-00B
Type number	PPP-TGGV-NNQ-XX	MAX-F10S-00B-00

Table 24: Product code formats

9.3 Ordering codes

Ordering code	Product	Remark
MAX-F10S-00B	u-blox F10 multi-band GNSS receiver module, LCC, professional grade	

Table 25: Product ordering codes



Product changes affecting form, fit or function are documented by u-blox. For a list of Product Change Notifications (PCNs) see our website at: <https://www.u-blox.com/en/product-resources>.

Related documents

- [1] MAX-F10S Integration manual, [UBXDOC-963802114-12892](#)
- [2] u-blox F10 SPG 6.00 Interface description, [UBX-23002975](#)
- [3] u-blox F10 SPG 6.00 Release note, [UBXDOC-963802114-12318](#)
- [4] Product packaging reference guide, [UBX-14001652](#)
- [5] Joint IPC/JEDEC standard, www.jedec.org



For regular updates to u-blox documentation and to receive product change notifications please register on our homepage <https://www.u-blox.com>.

Revision history

Revision	Date	Comments
R01	14-Aug-2024	Engineering sample
R02	28-Aug-2024	Initial production Added section <ul style="list-style-type: none">• Packaging Updated sections <ul style="list-style-type: none">• Absolute maximum ratings• Operating conditions• Indicative power requirements• Qualifications and approvals• Related documents

Contact

u-blox AG

Address: Zürcherstrasse 68
8800 Thalwil
Switzerland

For further support and contact information, visit us at www.u-blox.com/support.

X-ON Electronics

Largest Supplier of Electrical and Electronic Components

Click to view similar products for [U-Blox](#) manufacturer:

Other Similar products are found below :

[ADP-LEXI-R422-01](#) [ADP-LEXI-R520-02](#) [ADP-R10801D-00](#) [ADP-R8001-00C](#) [ADP-R8001M10-00C](#) [ADP-SARA-R500E-01](#) [ADP-SARA-R520-02](#) [ADP-SARA-R520M10-02](#) [ANNA-B112-02B](#) [ANT-B10-00C](#) [ANT-B10-10C](#) [ANT-B11-00C](#) [ANT-B11-10C](#) [BMD-300-A-R](#) [BMD-300-EVAL](#) [BMD-301-EVAL](#) [BMD-330-A-R](#) [BMD-330-EVAL](#) [BMD-340-EVAL](#) [BMD-350-A-R](#) [BMD-350-EVAL](#) [C212-NORA-B126](#) [EVA-M8Q-0](#) [EVK-LEXI-R422-01](#) [EVK-LILY-W132](#) [EVK-M8QCAM-0](#) [EVK-NINA-B501](#) [EVK-NINA-B506](#) [EVK-NINA-W101](#) [EVK-NINA-W102](#) [EVK-NINA-W131](#) [EVK-NORA-B120](#) [EVK-NORA-B126](#) [EVK-R10801D-00](#) [EVK-R422M10S-0](#) [EVK-R422M8S-0](#) [EVK-R8001-00C](#) [EVK-R8001M10-00C](#) [EVK-SARA-R500E-01](#) [EVK-SARA-R520-02](#) [EVK-SARA-R520M10-02](#) [IRIS-W101-00B](#) [IRIS-W106-00B](#) [JODY-W263-00A](#) [JODY-W263-01A](#) [JODY-W354-00A](#) [JODY-W374-00A](#) [LEA-M8T-1](#) [M2-JODY-W263-10C](#) [M2-MAYA-W161-10C](#)