

# APPROVAL SHEET

To :

Customer P/N :

UDE P/N : RU4-ZZ-0105

Description : RJ45 Tab up over USB 2.0 stack

Through Hole

2.5G Base-T

Contact Area : 30 $\mu$ " Min. Gold

LED : L-Green/Orange; R-Yellow



Spec No.  
RU419056-00

Update Date  
2019/9/12

Revision  
A

Approved	Checked	Prepared



湧德電子 股份有限公司  
UDE Corp.

桃園市(33852) 蘆竹區內溪路 68 巷13號

No.13, Ln. 68, Neixi Rd., Luzhu Dist., Taoyuan City (33852), Taiwan

TEL: 886-3-3242000 FAX: 886-3-3246611

<http://www.ude-corp.com/>

Revision History

Issue Date	Revision	Comments	Operator
2019/9/12	A	Initial Release .	Joyce

1. MECHANICAL DIMENSION

Product Dimension

Unit:mm	General Tolerance :	X.X : ± 0.38
		X.XX : ± 0.20

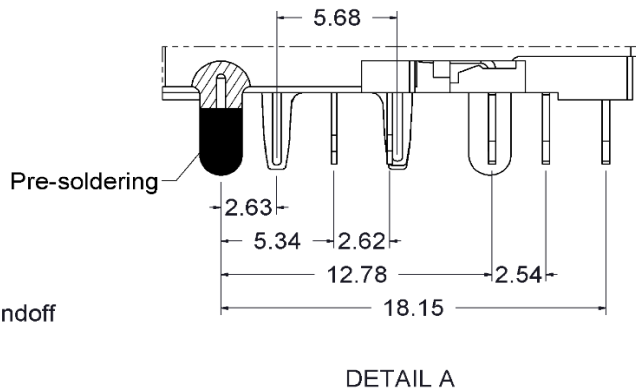
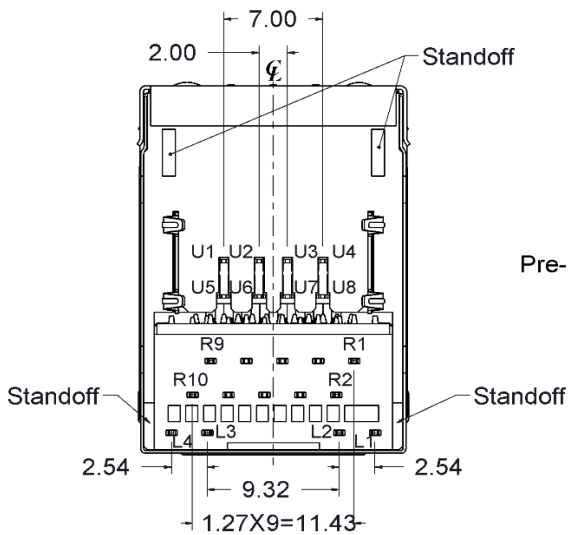
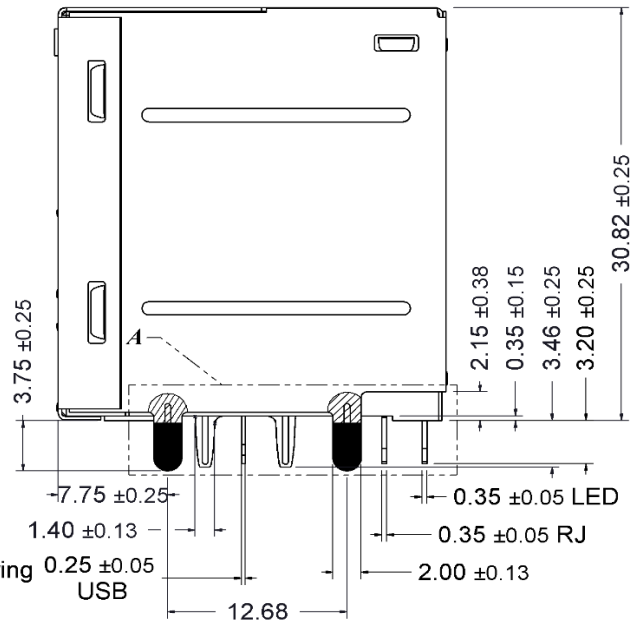
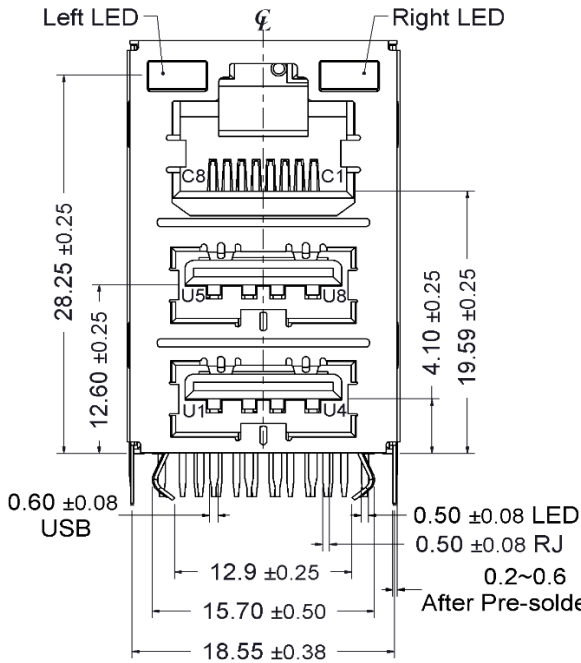
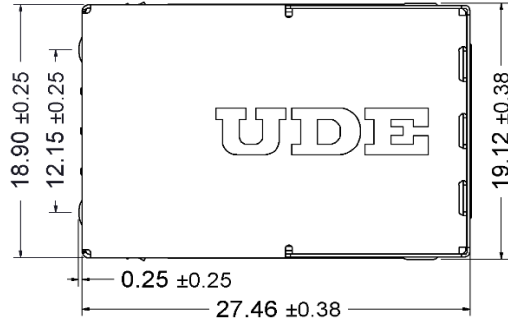
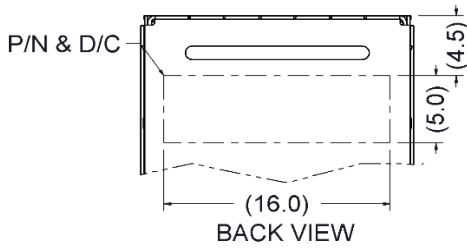

Recommended PCB Layout. Component side of board

All dimension units are "mm".

All dimension tolerances are ±0.05mm unless otherwise specified.

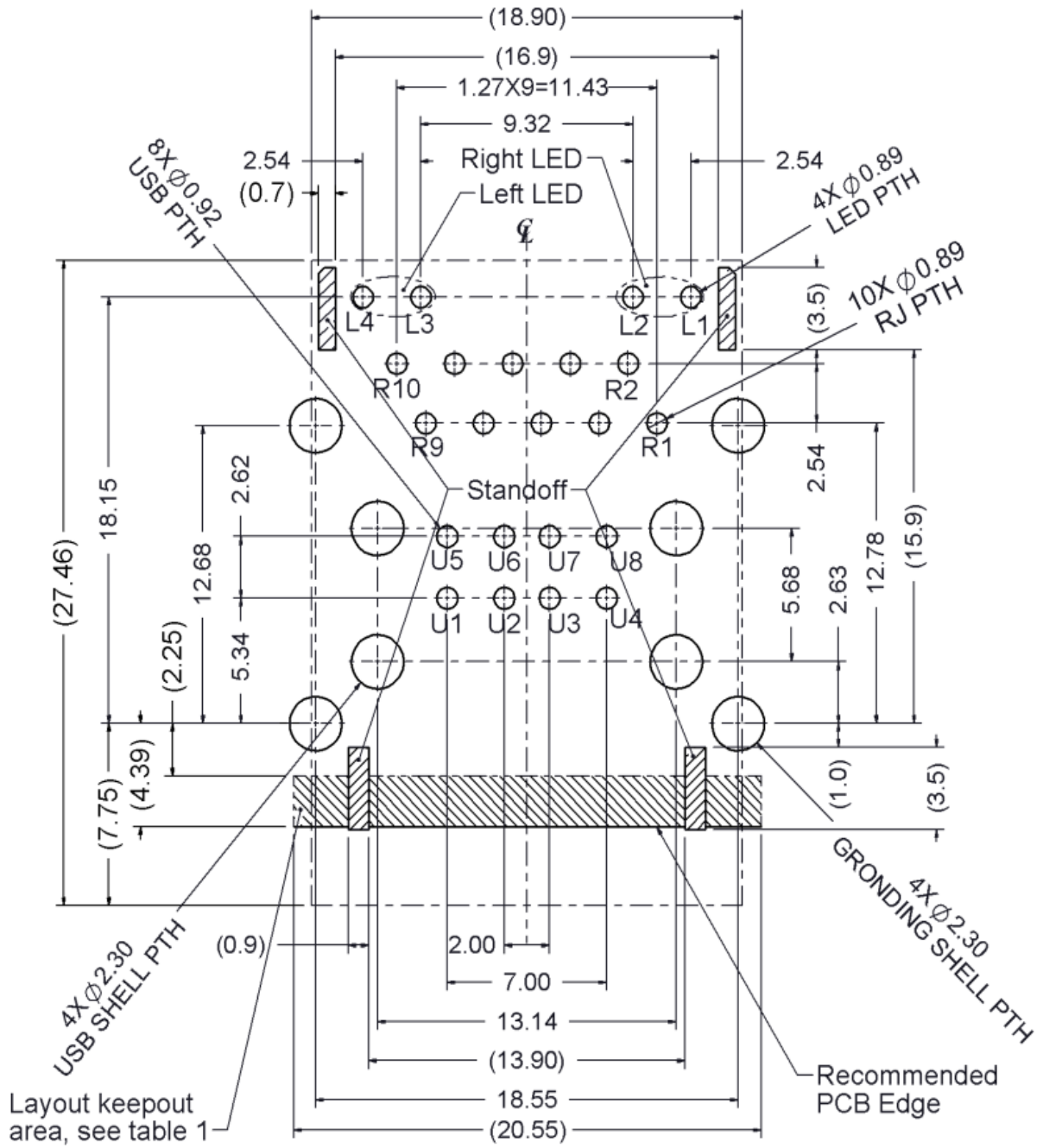
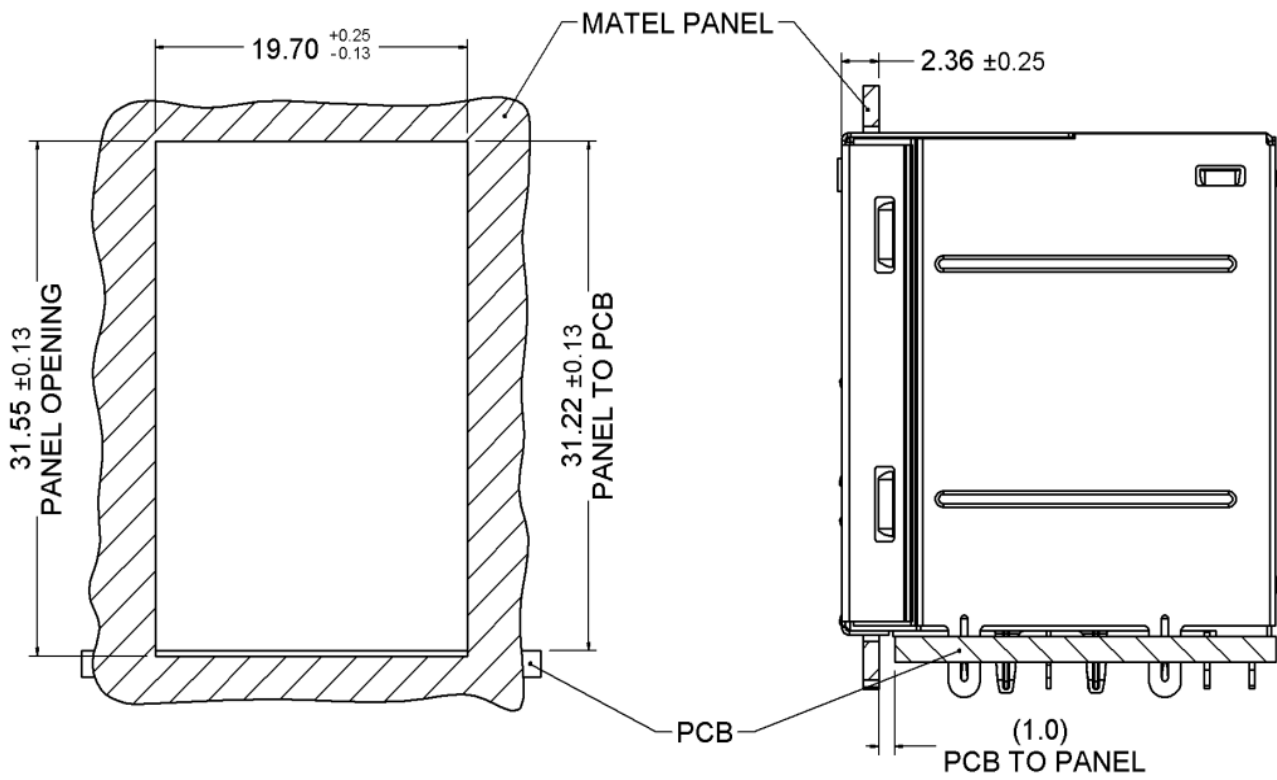

Table1

Layout Layer	Trace	component	Grounding	Test Point	Via Hole	PTH	NPTH
Component side	X	X	O	X	X	X	O
Inner layer	O	NA	O	NA	O	X	O
Bottom side	O	O	O	O	O	X	O

X--Forbid; O--OK; NA--Not Applicable.

Recommended Panel cutout



2. Packing Information

40 pcs finished goods per tray

5 trays(200 pcs finished goods) per inner box

4 Inner boxes(800 pcs finished goods) per master carton

### 3. Standard RJ45 Plug Specification

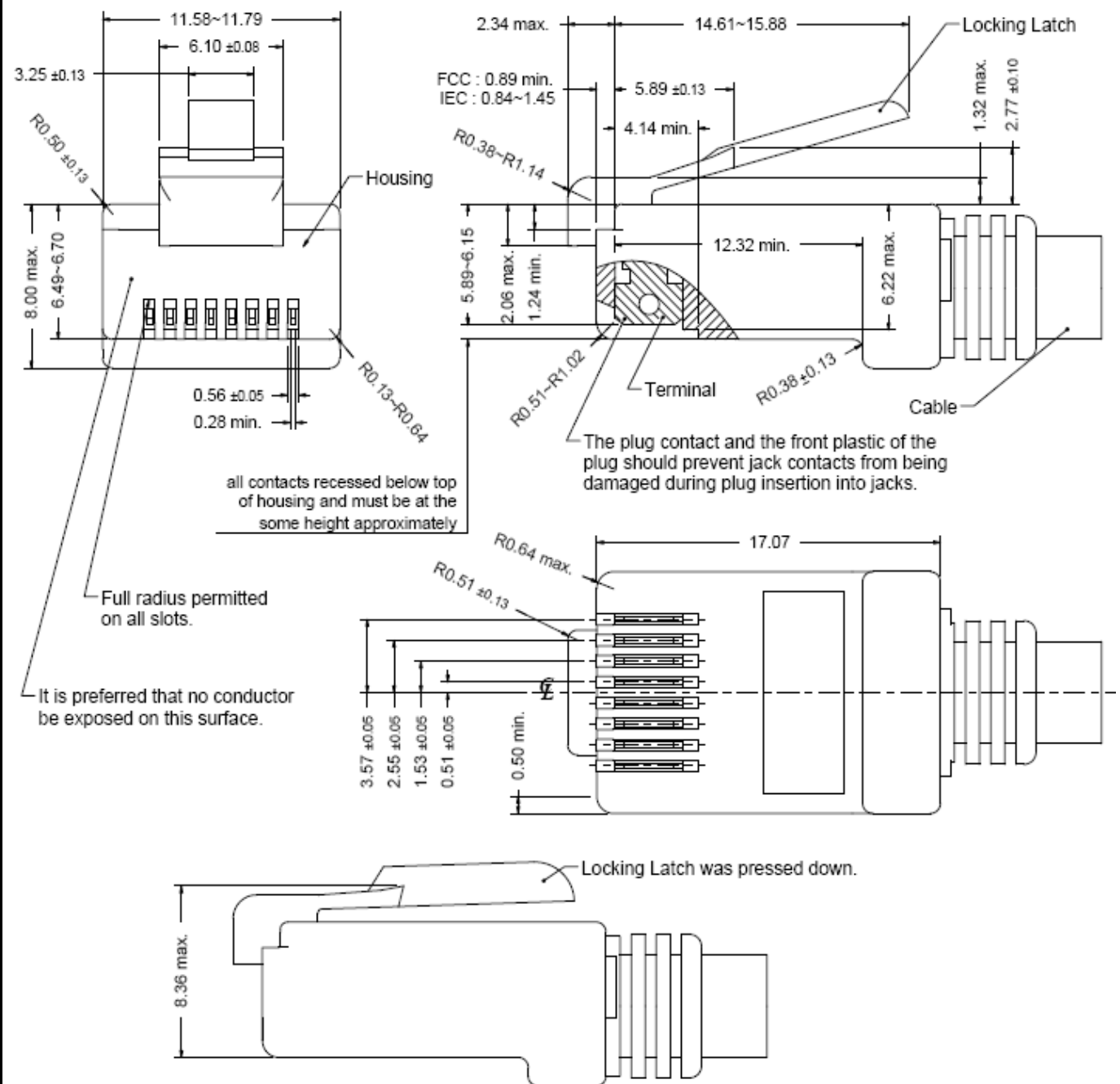

- All dimensions follow :  
 FCC subpart F, 68,500, Figure (C)(2)(i) & (C)(2)(ii) & (C)(3)(i)  
 IEC 60603-7
- All plugs must be meeting the requirements of plug Go & No-Go gauge.  
 Gauge follow : FCC subpart F, 68,500, Figure (C)(4)(i) & (C)(5)(i)
- There must be no damage to Housing and Locking Latch.
- There must be no nicks and cuts in cable.
- Durability : 750 cycles generally

### 4. Standard USB 2.0 Plug Specification

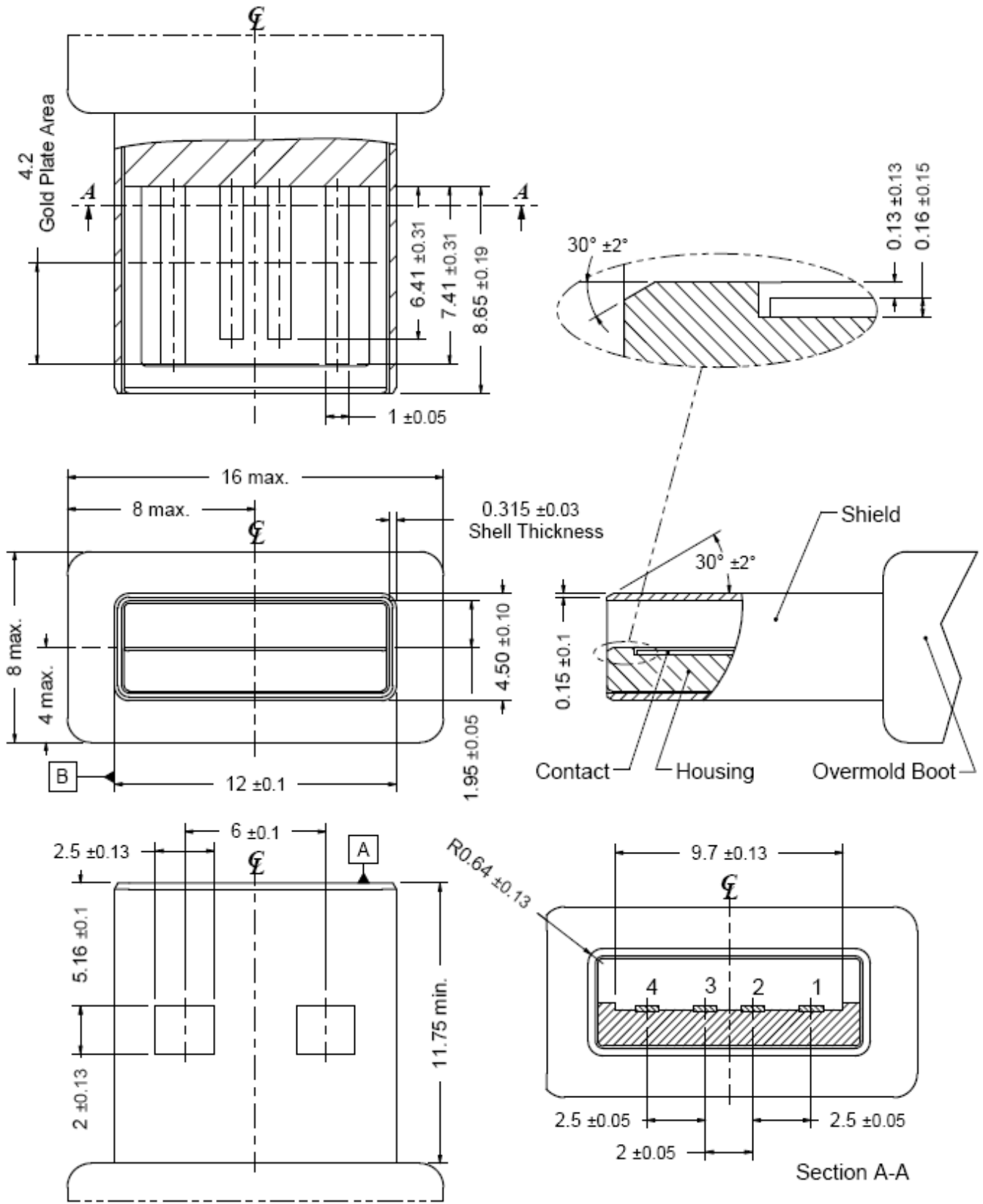

- All dimensions follow : Universal Series Bus Specification 2.0 (April 27,2000)  
Figure 6-9. USB Series A Plug Interface Drawing

## 5. REQUIREMENTS

### Design and Construction

Product shall be of design, construction and physical dimensions specified on applicable.

### Material

Terminal Parts (Underplating : 50 $\mu$ " min. Nickel overall)

RJ Terminal : Phosphor Bronze, Thickness=0.30mm

Finish Contact Area : 30 $\mu$ " min. Gold

USB Terminal : Phosphor Bronze, Thickness=0.25mm

Finish Contact Area : 30 $\mu$ " min. Gold

Solder Tail : 100 $\mu$ " min. Bright Tin

Input Terminal : Brass, Thickness=0.35mm

Finish : 100 $\mu$ " min. Bright Tin

Case Terminal : CP Wire, Diameter=0.40mm

Finish : 100 $\mu$ " min. Bright Tin

Plastic Parts <UL94V-0>

Housing : PBT, Black

Case : PF2A5-151J(b), Black

Spacer : PBT, Black

Shield Parts

Front Shield : stainless steel, Thickness=0.25mm, unplating

Back Shield : stainless steel, Thickness=0.20mm, Pre-soldering

USB Kink : Brass, Thickness=0.25mm

Finish : 100 $\mu$ " min. Tin over 30 $\mu$ " min. Nickel overall



## 6. Operating and Storage Temperature

Operating Temperature : 0°C to +70°C

Storage Temperature : -40°C to +85°C

## 7. RJ45 specifications

Insulation Resistance : 500MΩ min.

Insertion force with the latch depressed : 20N max.

Removal force with the latch depressed : 20N max.

Locking Force of Plug Latch : 50N min. @ 60+/-5 sec.

Durability : 2500 cycles

## 8. USB 2.0 specifications

Insulation Resistance : 1000MΩ min.

Dielectric Withstanding Voltage : 500Vac @1min.

Insertion force : 35N max.

Removal force : 10N min.

Durability : 1500 cycles

## 9. Performance and Test Description

Product is designed to meet electrical, mechanical and environmental performance requirements specified in below table.

All tests are performed at ambient environmental conditions per MIL-STD-1344A and EIA-364 unless otherwise specified.

## 10 Packaging and Packing

All parts shall be packaged and packed to protect against physical damage, corrosion and deterioration during shipment and storage.

11. USB 2.0 Standard-A Schematic

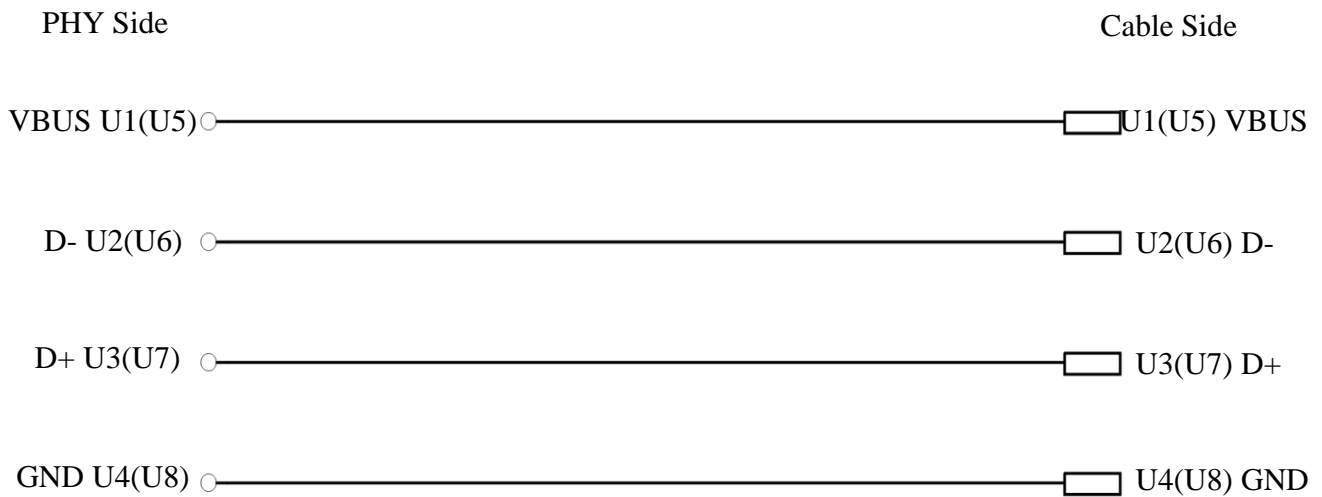

USB 2.0 Standard-A Pin Assignment

Pin Number	Signal Name	Description	Mating Sequence
U1&U5	VBUS	Power	Second
U2&U6	D-	USB 2.0 Differential pair	Third
U3&U7	D+		
U4&U8	GND	Ground for power return	Second
Shell	Shield	Connector metal shell	First

12. ELECTRICAL CHARACTERISTICS @25°C

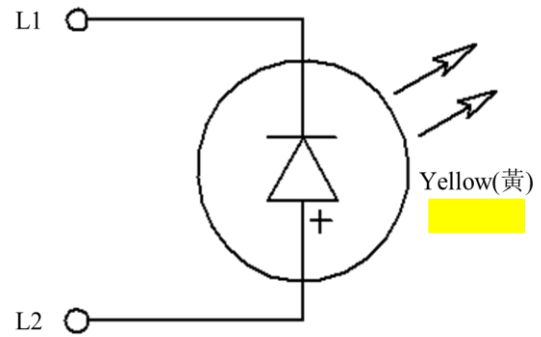
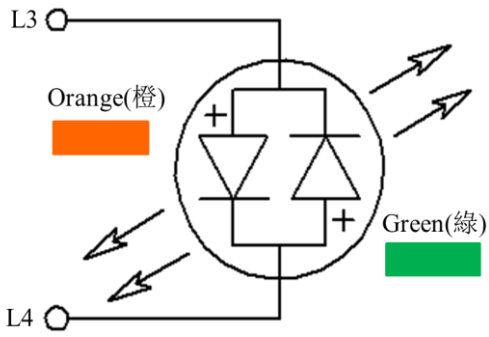
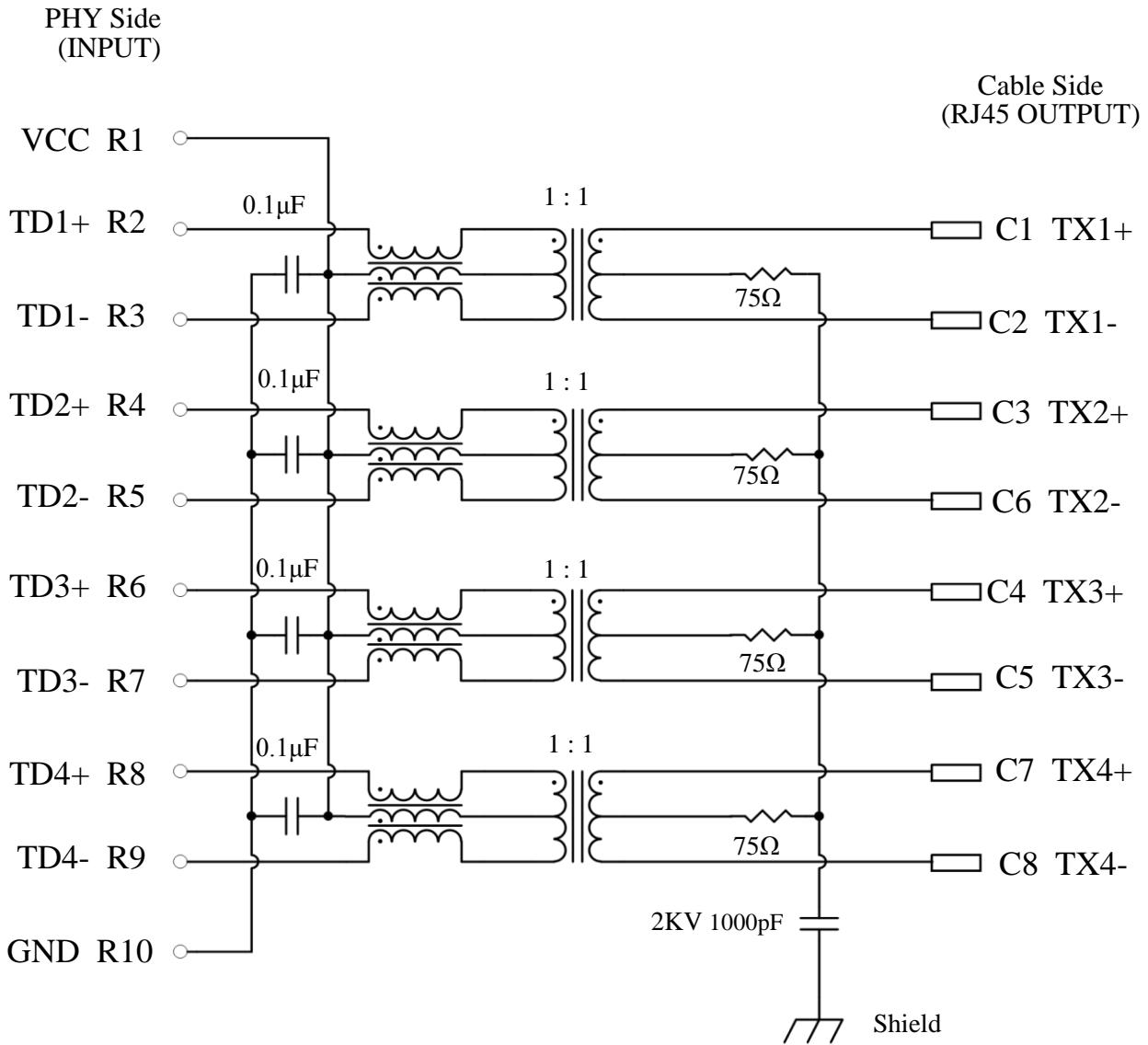

Emitting Color	$\lambda_p$ (nm)	$V_f$ @ $I_f=20mA$	$I_r$ @ $V_r=5V$
Green	570	1.7 ~2.6 V	10 $\mu$ A max.
Yellow	588	1.7 ~2.6 V	10 $\mu$ A max.
Orange	605	1.7 ~2.6 V	10 $\mu$ A max.

## Transmitter filter &amp; Receiver filter

Type : Balance low pass 100Ω impedance

Insertion loss : 1~50MHz -0.5dB max.

50~125MHz -1.0dB max.

125~200MHz -2.0dB max.

Return loss : 1~40MHz -20dB min.

40~200MHz  $-20+15*\log(\text{Freq MHz}/40\text{MHz})$  dB min.

## Reflected CM to Diff Conversion(REF)

1MHz -30dB min.

50MHz -30dB min.

100MHz -27dB min.

200MHz -24dB min.

## CM to DM Conversion(REF)

1-50MHZ -35 dB min

125MHZ -30 dB min

200MHZ -25 dB min

## Reflected Diff to CM Conversion(REF)

1-10MHZ -48 dB min

10-200MHz  $-48+19*\log(\text{Freq MHz}/10\text{MHz})$  dB min

## CM to CM Attenuation (REF)

1-200MHZ -25 dB min

## Cross Talk

1~40MHz -35dB min.

40~125MHz  $-35+15\log((\text{Freq MHz}/40\text{MHz}))$  dB min.

## Inductance (OCL) @ 100KHz, 0.1V, 8mA DC BIAS

Input(TD1+,TD1-) ; (TD2+,TD2-) ; (TD3+,TD3-) ; (TD4+,TD4-) : 180 μH min.

## HiPot Test

PHY Side(input) To Cable Side(output) : 1500Vac 60s or 2250Vdc 60s

### 13. WAVE SOLDERING TEMPERATURE PROFILE

Note :

The measuring point for the specified temperature shall be on the soldered part of the lead.

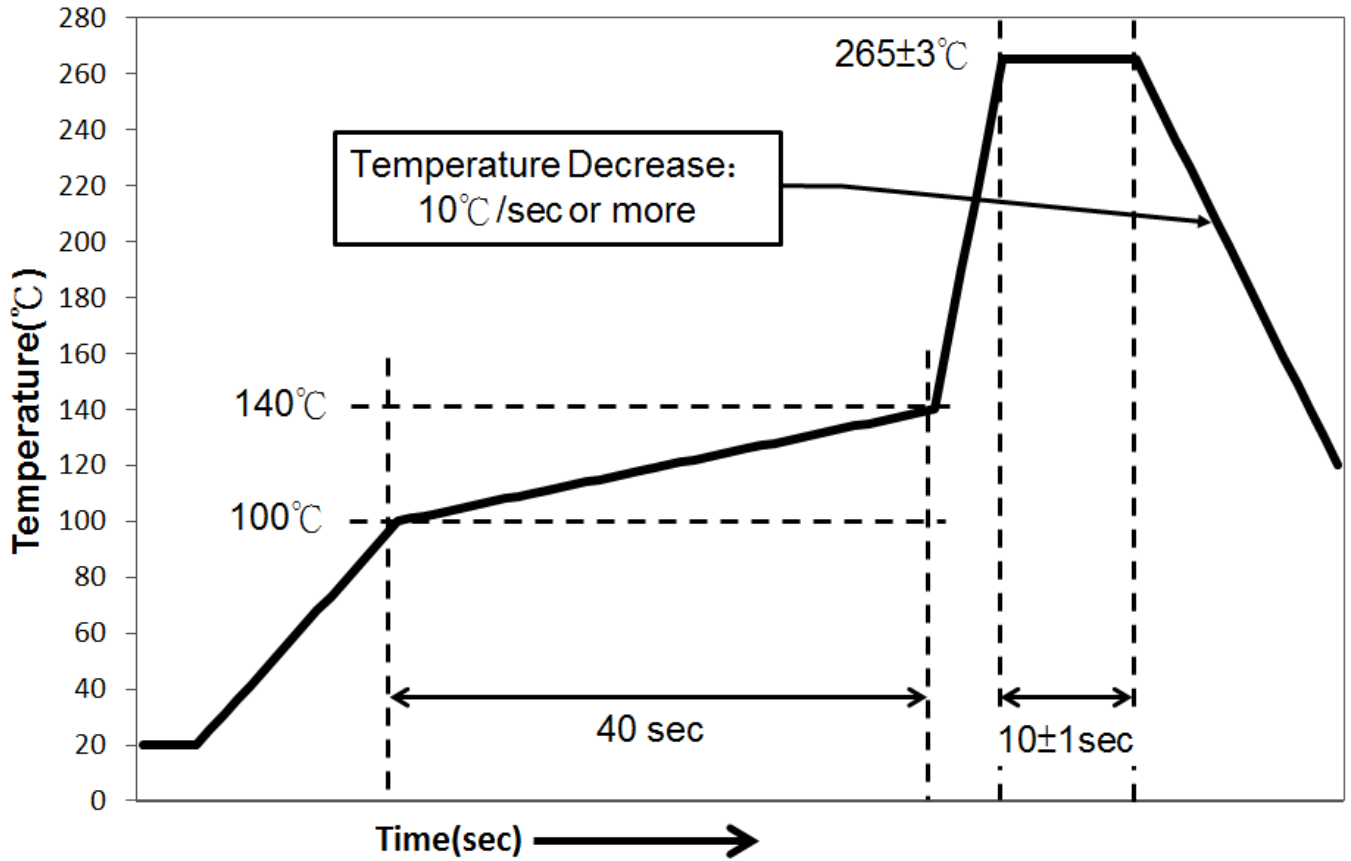

## X-ON Electronics

Largest Supplier of Electrical and Electronic Components

*Click to view similar products for [Modular Connectors](#) / [Ethernet Connectors](#) category:*

*Click to view products by [UDE manufacturer](#):*

Other Similar products are found below :

[8949-H88/06BLKA/SN](#) [74441-0010/BKN](#) [PHP-6P6C-5](#) [GAX-3-66](#) [GDCX-PN-66](#) [GLX-A-44](#) [GLX-N-1010M-BLK](#) [GLX-S-88M-BLK](#)  
[GMX-SMT4-N-88](#) [GSGX-N-2-88](#) [GSGX-N-4-88](#) [GSX-NS2-88-3.05](#) [GSX-NS-88-3.68](#) [PT-108A-8C-UL](#) [PTS-J531-8CS-50UL](#) [A-2014-0-4](#)  
[GWLX-S9-88-YG](#) [DC-1021-8-WH-6](#) [1300530003](#) [1324640-4](#) [132764-001](#) [1413235](#) [MPS88RX-5000](#) [E5288-S000K3-L](#) [155302-001](#)  
[AX101050](#) [AX101063](#) [AX101065](#) [AX101072](#) [AX101307](#) [AX101315](#) [AX101318](#) [AX102271](#) [AX102277](#) [AX102651](#) [AX102660](#) [AX104024](#)  
[203475](#) [PC4D0018P](#) [KIT38082NI](#) [8949-B88/6](#) [2-6609208-5](#) [30-8956](#) [30-8964-100](#) [SM85](#) [SM99S01VBNN04G7](#) [17-103540](#) [191587](#) [PDI-68-RV](#) [PHP-8P8C-S-5](#)