

8-Bit Dual-Supply Bus Transceiver With Configurable Voltage Translation and 3-State Outputs

UM3608AO SSOP24

UM3608UO TSSOP24

UM3608QA QFN24 3.5×5.5

General Description

UM3608 are octal bus transceivers that utilize deep micron CMOS Technology are intended for bus oriented application. This 8-bit non-inverting bus transceiver uses two separate configurable power-supply rails to implement universal low voltage bidirectional translation between any of the 1.8V, 2.5V, 3.3V and 5.5V voltage nodes. The UM3608 is optimized to operate with V_{CCA} and V_{CCB} set at 1.65V to 5.5V. The A port is designed to track V_{CCA} . V_{CCA} accepts any supply voltage from 1.65V to 5.5V. The B port is designed to track V_{CCB} . V_{CCB} accepts any supply voltage from 1.65V to 5.5 V.

The UM3608 is designed for asynchronous communication between two data buses. The logic levels of the direction-control (DIR) input and the output-enable (OE) input activate either the B-port outputs or the A-port outputs or place both output ports into the high-impedance mode. The device transmits data from the A bus to the B bus when the B-port outputs are activated, and from the B bus to the A bus when the A-port outputs are activated. The input circuitry on both A and B ports must have a logic HIGH or LOW level applied to prevent excess I_{CC} and I_{CCZ} .

UM3608 is fully specified for partial power down applications using I_{off} . The I_{off} circuitry disables the outputs, preventing damaging the current back flow through the device when it is powered down. The V_{CC} isolation feature ensures that if either V_{CC} Input is at GND, all outputs are in the high impedance state. To ensure the high impedance state during power up or power down. OE should be tied to V_{CC} through a pull up resistor. The UM3608 is designed so that the control pins (DIR and OE) are supplied by V_{CCA} .

The UM3608 series are available in SSOP24, TSSOP24 and QFN24 3.5×5.5 packages.

Applications

- Personal Electronic
- Industrial
- Enterprise
- Telecom

Features

- Control Inputs V_{IH}/V_{IL} Levels Are Referenced to V_{CCA} Voltage
- V_{CC} Isolation Feature – If Either V_{CC} Input Is at GND, All Are in the High-Impedance State
- Fully Configurable Dual-Rail Design Allows Each Port to Operate Over the Full 1.65V to 5.5V Power-Supply Range
- Latch-Up Performance Exceeds 100 mA Per JESD 78, Class II
- ESD Protection Exceeds JESD22 4000V Human-Body Model (A114-A) 100V Machine Model (A115-A) 1000V Charged-Device Model (C101)
- Available in SSOP24, TSSOP24 and QFN24 3.5×5.5 Packages
- Maximum Data Rates
150 Mbps ($V_{CCA} < 3.3$ V or $V_{CCB} < 3.3$ V)
220 Mbps ($V_{CCA} \geq 3.3$ V and $V_{CCB} \geq 3.3$ V)

Logic Diagram (Positive Logic)

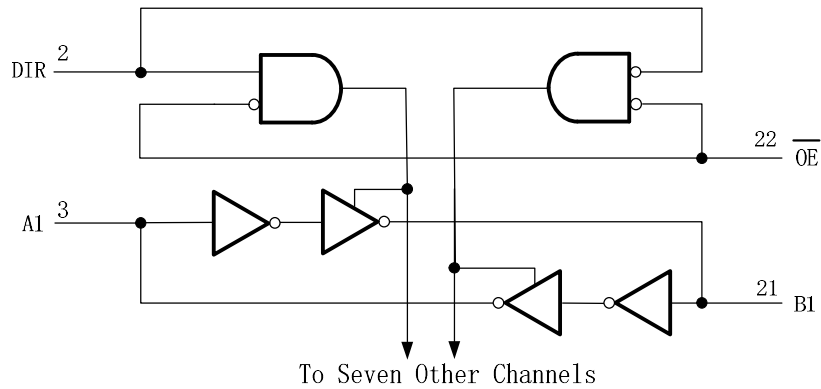

Pin Configurations

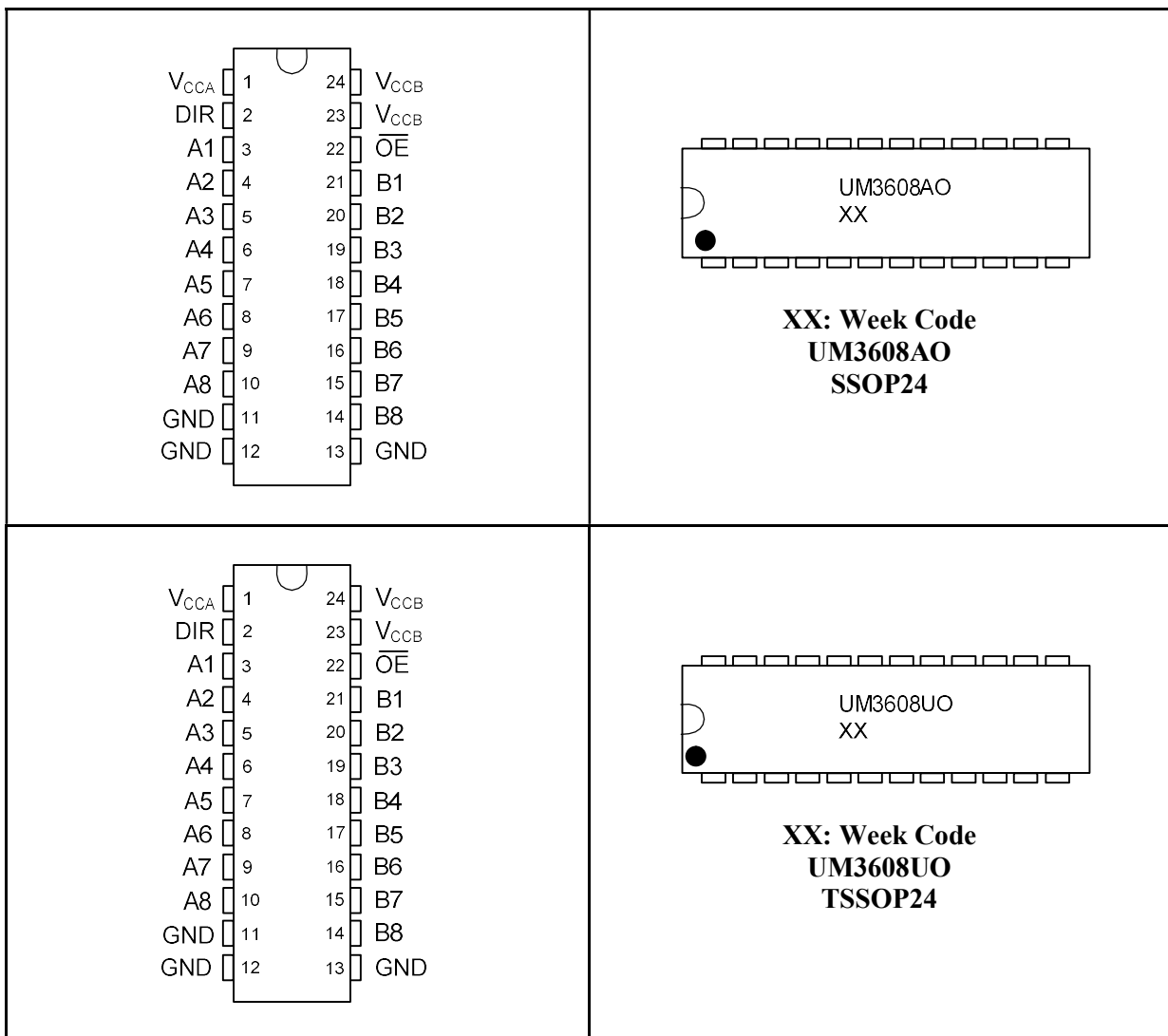

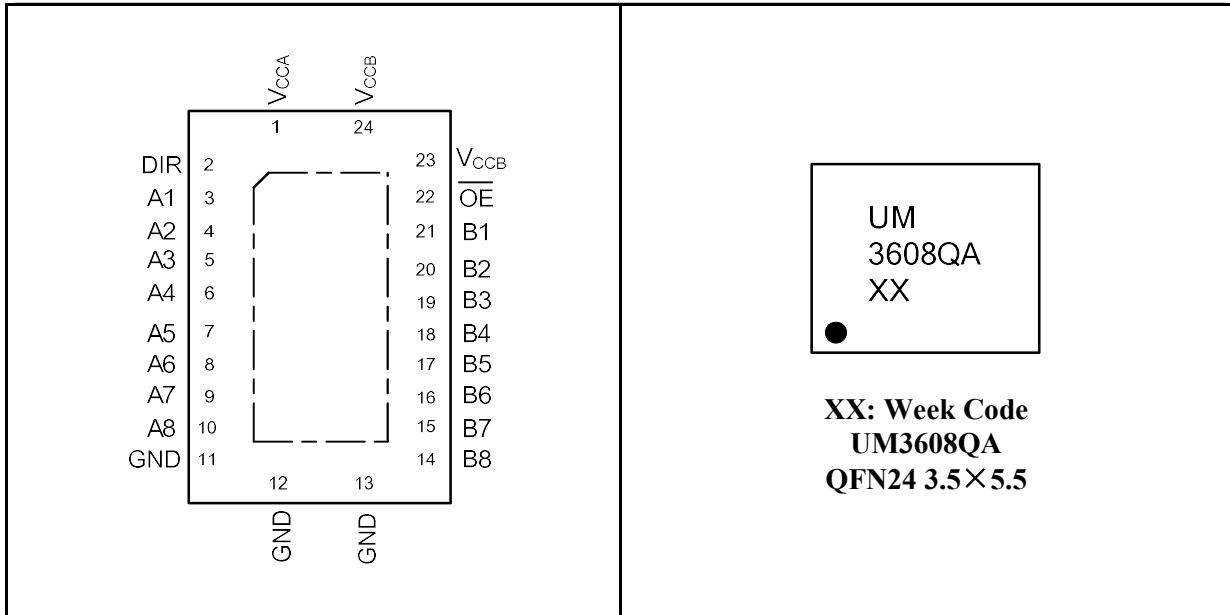

Pin Descriptions

Pin No.	Pin Name	Function
1	V _{CCA}	A-port supply voltage. $1.65\text{ V} \leq V_{CCA} \leq 5.5\text{ V}$.
2	DIR	Direction-control signal.
3	A1	Input/output A1. Referenced to V _{CCA} .
4	A2	Input/output A2. Referenced to V _{CCA} .
5	A3	Input/output A3. Referenced to V _{CCA} .
6	A4	Input/output A4. Referenced to V _{CCA} .
7	A5	Input/output A5. Referenced to V _{CCA} .
8	A6	Input/output A6. Referenced to V _{CCA} .
9	A7	Input/output A7. Referenced to V _{CCA} .
10	A8	Input/output A8. Referenced to V _{CCA} .
11-13	GND	Ground.
14	B8	Input/output B8. Referenced to V _{CCB} .
15	B7	Input/output B7. Referenced to V _{CCB} .
16	B6	Input/output B6. Referenced to V _{CCB} .
17	B5	Input/output B5. Referenced to V _{CCB} .
18	B4	Input/output B4. Referenced to V _{CCB} .
19	B3	Input/output B3. Referenced to V _{CCB} .
20	B2	Input/output B2. Referenced to V _{CCB} .
21	B1	Input/output B1. Referenced to V _{CCB} .
22	OE	3-state output-mode enables. Pull OE high to place all outputs in 3-state mode. Referenced to V _{CCA} .
23-24	V _{CCB}	B-port supply voltage. $1.65\text{ V} \leq V_{CCB} \leq 5.5\text{ V}$.

Ordering Information

Part Number	Marking	Package Type	Shipping Qty
UM3608AO	UM3608AO	SSOP24	2000pcs/13Inch Tape & Reel
UM3608UO	UM3608UO	TSSOP24	3000pcs/13Inch Tape & Reel
UM3608QA	UM3608QA	QFN24 3.5×5.5	3000pcs/13Inch Tape & Reel

Absolute Maximum Ratings (Note 1)

Over operating free-air temperature range (unless otherwise noted)

Symbol	Parameter	Value	Unit
V_{CCA}	Supply Voltage Range	-0.5 to +6.5	V
V_{CCB}	Supply Voltage Range	-0.5 to +6.5	V
V_I	Input Voltage Range (Note 2)	A ports	-0.5 to +6.5
		B ports	-0.5 to +6.5
V_O	Voltage Range Applied to Any Output in the High-Impedance or Power-Off State (Note 2)	A ports	-0.5 to +6.5
		B ports	-0.5 to +6.5
V_O	Voltage Range Applied to Any Output in the High or Low State (Note 2, 3)	A ports	-0.5 to ($V_{CCA}+0.5$)
		B ports	-0.5 to ($V_{CCB}+0.5$)
I_{IK}	Input Clamp Current	$V_I < 0$	-50
I_{OK}	Output Clamp Current	$V_O < 0$	-50
I_O	Continuous Output Current		± 50
	Continuous Current through V_{CCA} , V_{CCB} , or GND		± 100
T_{OP}	Operating Temperature Range	-40 to +85	$^{\circ}\text{C}$
T_J	Operating Junction Temperature	-40 to +125	$^{\circ}\text{C}$
T_{STG}	Storage Temperature Range	-65 to +150	$^{\circ}\text{C}$

Note 1: Stresses beyond those listed under "absolute maximum ratings" may cause permanent damage to the device. These are stress ratings only, and functional operation of the device at these or any other conditions beyond those indicated under "recommended operating conditions" is not implied. Exposure to absolute-maximum-rated conditions for extended periods may affect device reliability.

Note 2: The input and output negative-voltage ratings may be exceeded if the input and output current ratings are observed.

Note 3: The value of V_{CCA} and V_{CCB} are provided in the recommended operating conditions table.

Package Thermal Impedance

Symbol	Parameter	Value	Unit
$R_{\theta JA}$	Junction-to-ambient thermal resistance	SSOP24	88.5
		TSSOP24	90.6
		QFN24 3.5×5.5	37.4
$R_{\theta JC(top)}$	Junction-to-case (top) thermal resistance	SSOP24	48.7
		TSSOP24	27.6
		QFN24 3.5×5.5	38.1
$R_{\theta JB}$	Junction-to-board thermal resistance	SSOP24	44.1
		TSSOP24	45.3
		QFN24 3.5×5.5	15.2

ESD Rating

Symbol	Parameter	Value	Unit
ESD Protection	Human body model (HBM)	-4000 to +4000	V
	Charged device model (CDM)	-1000 to +1000	

Recommended Operating Conditions (Note 1, 2,3,4)

Symbol	Parameter		V _{CCI}	V _{CCO}	Min	Max	Unit
V _{CCA}	Supply Voltage				1.65	5.5	V
V _{CCB}					1.65	5.5	
V _{IH}	High Level Input Voltage	Data Inputs ⁽⁵⁾	1.65 V to 1.95 V		V _{CCI} ×0.65		V
			2.3 V to 2.7 V		1.7		
			3 V to 3.6 V		2		
			4.5 V to 5.5 V		V _{CCI} ×0.7		
V _{IL}	Low Level Input Voltage	Data Inputs ⁽⁵⁾	1.65 V to 1.95 V			V _{CCI} ×0.35	V
			2.3 V to 2.7 V			0.7	
			3 V to 3.6 V			0.8	
			4.5 V to 5.5 V			V _{CCI} ×0.3	
V _{IH}	High Level Input Voltage	Control inputs (referenced to V _{CCA}) ⁽⁶⁾	1.65 V to 1.95 V		V _{CCI} ×0.65		V
			2.3 V to 2.7 V		1.7		
			3 V to 3.6 V		2		
			4.5 V to 5.5 V		V _{CCI} ×0.7		
V _{IL}	Low Level Input Voltage	Control inputs (referenced to V _{CCA}) ⁽⁶⁾	1.65 V to 1.95 V			V _{CCI} ×0.35	V
			2.3 V to 2.7 V			0.7	
			3 V to 3.6 V			0.8	
			4.5 V to 5.5 V			V _{CCI} ×0.3	
V _I	Input voltage	Control Inputs			0	5.5	V
V _{I/O}	Input/output voltage	Active state			0	V _{CCO}	V
		Three-State			0	5.5	
I _{OH}	High-level output current		1.65 V to 1.95 V			-4	mA
			2.3 V to 2.7 V			-8	
			3 V to 3.6 V			-24	
			4.5 V to 5.5 V			-32	
I _{OL}	Low-level output current		1.65 V to 1.95 V			4	mA
			2.3 V to 2.7 V			8	
			3 V to 3.6 V			24	
			4.5 V to 5.5 V			32	
Δt/ΔV	Input Transition Rise or Fall Time	Data Inputs	1.65 V to 1.95 V			20	ns/V
			2.3 V to 2.7 V			20	
			3 V to 3.6 V			10	
			4.5 V to 5.5 V			5	

Note 1: V_{CCI} is the V_{CC} associated with the data input port.

Note 2: V_{CCO} is the V_{CC} associated with the output port.

Note 3: All unused or driven (floating) data inputs (I/Os) of the device must be held at logic HIGH or LOW (preferably V_{CCI} or GND) to ensure proper device operation and minimize power.

Note 4: All unused control inputs must be held at V_{CCA} or GND to ensure proper device operation and minimize power consumption.

Note 5: For V_{CCI} values not specified in the data sheet, V_{IH} min = V_{CCI} × 0.7 V, V_{IL} max = V_{CCI} × 0.3 V.

Note 6: For V_{CCA} values not specified in the data sheet, V_{IH} min = V_{CCA} × 0.7 V, V_{IL} max = V_{CCA} × 0.3 V.

Electrical Characteristics (Note 1, 2)

Over recommended operating free-air temperature range (unless otherwise noted)

Parameter	Test Conditions	V _{CCA}	V _{CCB}	T _A =25°C		-40°C to 85°C		Unit	
				Typ	Max	Min	Max		
V _{OH}	I _{OH} =-100μA, V _I =V _{IH}	1.65V to 4.5V	1.65V to 4.5V			V _{CCO} -0.1		V	
	I _{OH} =-4mA, V _I =V _{IH}	1.65V	1.65V			1.2			
	I _{OH} =-8mA, V _I =V _{IH}	2.3V	2.3V			1.9			
	I _{OH} =-24mA, V _I =V _{IH}	3V	3V			2.4			
	I _{OH} =-32mA, V _I =V _{IH}	4.5V	4.5V			3.8			
V _{OL}	I _{OL} =100μA, V _I =V _{IL}	1.65V to 4.5V	1.65V to 4.5V				0.1	V	
	I _{OL} =4mA, V _I =V _{IL}	1.65V	1.65V				0.45		
	I _{OL} =8mA, V _I =V _{IL}	2.3V	2.3V				0.3		
	I _{OL} =24mA, V _I =V _{IL}	3V	3V				0.55		
	I _{OL} =32mA, V _I =V _{IL}	4.5V	4.5V				0.55		
I _I	DIR	V _I = V _{CCA} or GND	1.65V to 5.5V	1.65V to 5.5V			±1	±2	μA
I _{off}	A or B Port	V _I or V _O = 0 to 5.5 V	0V	0V to 5.5V			±1	±2	μA
			0V to 5.5V	0V			±1	±2	
I _{OZ}	A or B Port	V _O = V _{CCO} or GND, OE = V _{IH}	1.65V to 5.5V	1.65V to 5.5V			±1	±2	μA
I _{CCA}		V _I =V _{CCI} or GND I _O =0	1.65V to 5.5V	1.65 V to 5.5 V				15	μA
			5 V	0 V				15	
			0 V	5 V				-2	
I _{CCB}		V _I =V _{CCI} or GND I _O =0	1.65V to 5.5V	1.65 V to 5.5 V				15	μA
			5 V	0 V				-2	
			0 V	5 V				15	
I _{CCA} +I _{CCB}		V _I =V _{CCI} or GND I _O =0	1.65V to 5.5V	1.65V to 5.5V				25	μA
ΔI _{CCA}	A port	One A port at V _{CCA} - 0.6 V, DIR at V _{CCA} , B port = open						50	μA
	DIR	DIR at V _{CCA} - 0.6 V, B port = open, A port at V _{CCA} or GND	3V to 5.5V	3V to 5.5V				50	
ΔI _{CCB}	B port	One B port at V _{CCB} - 0.6 V, DIR at GND, A port = open	3V to 5.5V	3V to 5.5V				50	μA
C _i	Control inputs	V _I =V _{CCI} or GND	3.3V	3.3V	4			5	pF
C _{io}	A or B Port	V _O = V _{CCA/B} or GND	3.3V	3.3V	8.5			10	pF

 Note 1: V_{CCI} is the supply voltage associated with the input port.

 Note 2: V_{CCO} is the supply voltage associated with the output port.

Switching Characteristics

 Over recommended operating free-air temperature range, $V_{CCA} = 1.8V \pm 0.15V$ (unless otherwise noted)

Parameter	From (Input)	To (Output)	$V_{CCB}=1.8V \pm 0.15V$		$V_{CCB}=2.5V \pm 0.2V$		$V_{CCB}=3.3V \pm 0.3V$		$V_{CCB}=5V \pm 0.5V$		Unit
			Min	Max	Min	Max	Min	Max	Min	Max	
t_{PLH}	A	B	1.7	21.9	1.3	9.2	1	7.4	0.8	7.1	ns
t_{PHL}											
t_{PLH}	B	A	0.9	23.8	0.8	23.6	0.7	23.4	0.7	23.4	ns
t_{PHL}											
t_{PHZ}	\overline{OE}	A	1.5	29.6	1.5	29.4	1.5	29.3	1.4	29.2	ns
t_{PLZ}											
t_{PHZ}	\overline{OE}	B	2.4	32.2	1.9	18.2	1.7	17.6	1.3	16.3	ns
t_{PLZ}											
t_{PZH}	\overline{OE}	A	0.4	26.5	0.4	25.8	0.4	25.7	0.4	25.7	ns
t_{PZL}											
t_{PZH}	\overline{OE}	B	1.8	32	1.5	17.5	1.2	16.6	0.9	15.8	ns
t_{PZL}											

Switching Characteristics

 Over recommended operating free-air temperature range, $V_{CCA} = 2.5V \pm 0.2V$ (unless otherwise noted)

Parameter	From (Input)	To (Output)	$V_{CCB}=1.8V \pm 0.15V$		$V_{CCB}=2.5V \pm 0.2V$		$V_{CCB}=3.3V \pm 0.3V$		$V_{CCB}=5V \pm 0.5V$		Unit
			Min	Max	Min	Max	Min	Max	Min	Max	
t_{PLH}	A	B	1.5	21.4	1.2	9	0.8	6.2	0.6	4.8	ns
t_{PHL}											
t_{PLH}	B	A	1.2	9.3	1	9.1	1	8.9	0.9	8.8	ns
t_{PHL}											
t_{PHZ}	\overline{OE}	A	1.4	17.8	1.4	17.7	1.4	16.5	1.4	16.6	ns
t_{PLZ}											
t_{PHZ}	\overline{OE}	B	2.3	29.6	1.8	13.3	1.7	11.7	0.9	11.5	ns
t_{PLZ}											
t_{PZH}	\overline{OE}	A	1	16.5	1	16.5	1	16.5	1	16.4	ns
t_{PZL}											
t_{PZH}	\overline{OE}	B	1.7	28.2	1.5	12.9	1.2	11.1	1	10.5	ns
t_{PZL}											

Switching Characteristics

 Over recommended operating free-air temperature range, $V_{CCA} = 3.3V \pm 0.3V$ (unless otherwise noted)

Parameter	From (Input)	To (Output)	$V_{CCB}=1.8V \pm 0.15V$		$V_{CCB}=2.5V \pm 0.2V$		$V_{CCB}=3.3V \pm 0.3V$		$V_{CCB}=5V \pm 0.5V$		Unit
			Min	Max	Min	Max	Min	Max	Min	Max	
t_{PLH}	A	B	1.5	21.2	1.1	8.8	0.8	6.3	0.5	4.4	ns
t_{PHL}											
t_{PLH}	B	A	0.8	7.2	0.8	6.2	0.7	6.1	0.6	6	ns
t_{PHL}											
t_{PHZ}	\overline{OE}	A	1.6	14.6	1.6	14.5	1.6	14.3	1.6	14.2	ns
t_{PLZ}											
t_{PHZ}	\overline{OE}	B	2.1	29	1.7	10.8	1.5	10.1	0.8	12.1	ns
t_{PLZ}											
t_{PZH}	\overline{OE}	A	0.8	13.7	0.8	13.5	0.8	13.3	0.8	13.2	ns
t_{PZL}											
t_{PZH}	\overline{OE}	B	1.8	27.7	1.4	12.4	1.1	9.5	0.9	8.9	ns
t_{PZL}											

Switching Characteristics

 Over recommended operating free-air temperature range, $V_{CCA} = 5V \pm 0.5V$ (unless otherwise noted)

Parameter	From (Input)	To (Output)	$V_{CCB}=1.8V \pm 0.15V$		$V_{CCB}=2.5V \pm 0.2V$		$V_{CCB}=3.3V \pm 0.3V$		$V_{CCB}=5V \pm 0.5V$		Unit
			Min	Max	Min	Max	Min	Max	Min	Max	
t_{PLH}	A	B	1.5	21.4	1	8.8	0.7	6	0.4	4.2	ns
t_{PHL}											
t_{PLH}	B	A	0.7	7	0.4	4.8	0.3	4.5	0.3	4.3	ns
t_{PHL}											
t_{PHZ}	\overline{OE}	A	0.3	11.6	0.3	11.5	0.3	11.3	0.3	11.2	ns
t_{PLZ}											
t_{PHZ}	\overline{OE}	B	2	28.7	1.6	9.7	1.4	8.9	0.7	7.8	ns
t_{PLZ}											
t_{PZH}	\overline{OE}	A	0.7	10.7	0.7	10.5	0.7	10.4	0.7	10.2	ns
t_{PZL}											
t_{PZH}	\overline{OE}	B	1.5	27.6	1.3	11.4	1	8.8	0.9	8.1	ns
t_{PZL}											

Operating Characteristics
 $T_A = 25^\circ C$

Parameter		Test Conditions	$V_{CCA}=V_{CCB}=1.8V$	$V_{CCA}=V_{CCB}=2.5V$	$V_{CCA}=V_{CCB}=3.3V$	$V_{CCA}=V_{CCB}=5V$	Unit
			Typ	Typ	Typ	Typ	
$C_{pdA(1)}$	A-port input, B-port output	$C_L = 0,$ $f = 10\text{ MHz},$ $t_r = t_f = 1\text{ ns}$	4	4	4	4	PF
	B-port input, A-port output		55	55	55	55	
$C_{pdB(1)}$	A-port input, B-port output		55	55	55	55	
	B-port input, A-port output		4	4	4	4	

(1) Power dissipation capacitance per transceiver

Typical Characteristics

Figure 1 V_{OL} Voltage vs I_{OL} Current

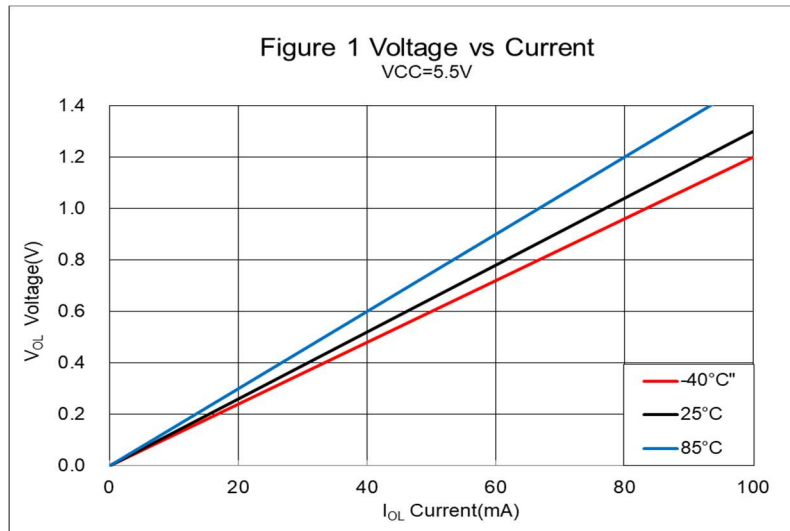
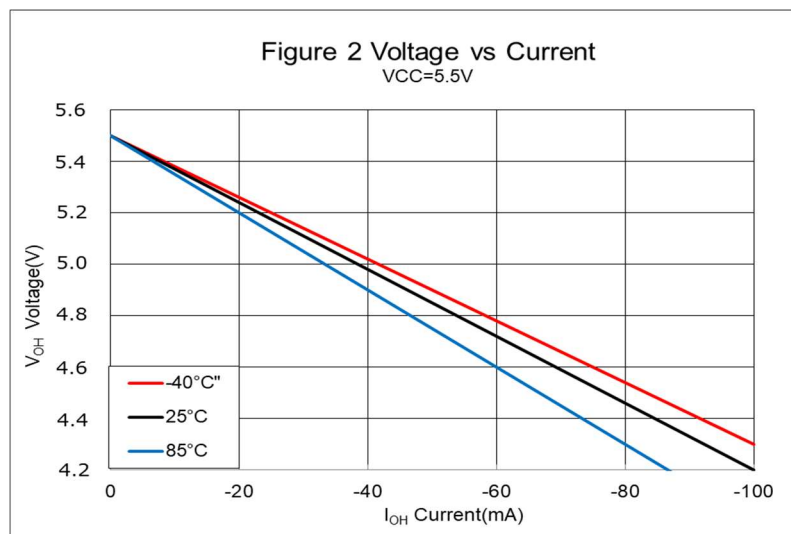
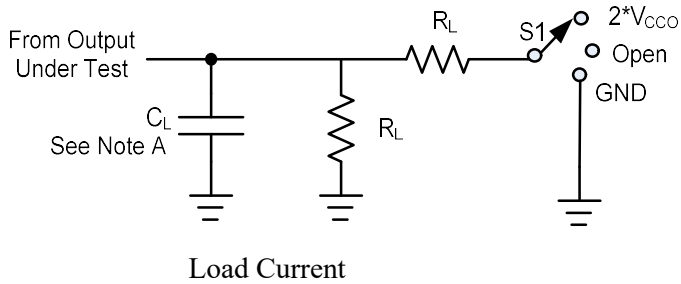

Figure 2 V_{OH} Voltage vs I_{OH} Current



Parameter Measurement Information



TEST	S1
tpd	Open
tPLZ/tPZL	2 × V _{CCO}
tPHZ/tPZH	GND

V _{CCO}	C _L	R _L	V _{TP}
1.8 V ± 0.15 V	15PF	2kΩ	0.15V
2.5V ± 0.2V	15PF	2kΩ	0.15V
3.3V ± 0.3V	15PF	2kΩ	0.3V
5V ± 0.5V	15PF	2kΩ	0.3V

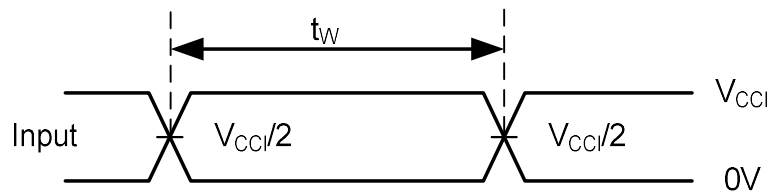

VOLTAGE WAVEFORMS PULSE DURATION

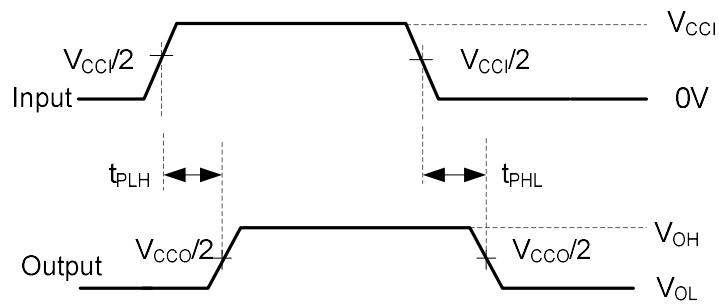

VOLTAGE WAVEFORMS PROPAGATION DELAY TIMES

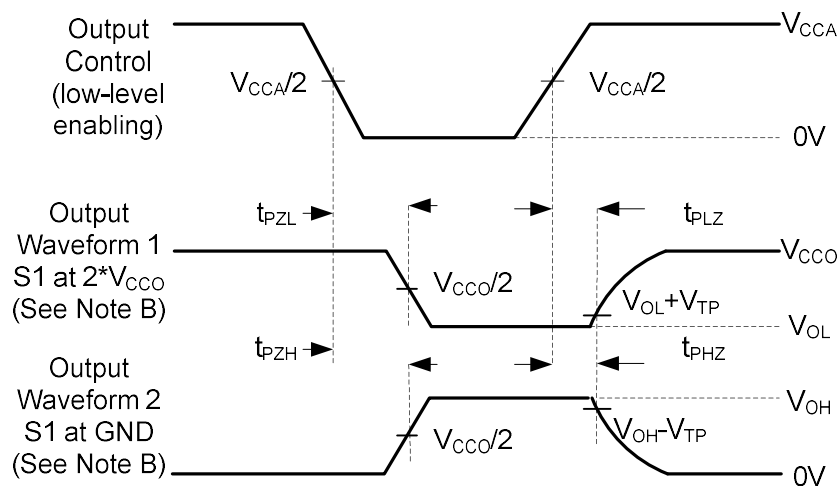

VOLTAGE WAVEFORMS ENABLE AND DISABLE TIMES

NOTES:

- A. C_L includes probe and jig capacitance.
- B. Waveform 1 is for an output with internal conditions such that the output is low, except when disabled by the output control. Waveform 2 is for an output with internal conditions such that the output is high, except when disabled by the output control.
- C. All input pulses are supplied by generators having the following characteristics: $PRR \leq 10$ MHz, $Z_O = 50\Omega$, $dv/dt \geq 1V/ns$.
- D. The outputs are measured one at a time, with one transition per measurement.
- E. t_{PLZ} and t_{PHZ} are the same as t_{dis} .
- F. t_{PZL} and t_{PZH} are the same as t_{en} .
- G. t_{PLH} and t_{PHL} are the same as t_{pd} .
- H. V_{CCI} is the V_{CC} associated with the input port.
- I. V_{CCO} is the V_{CC} associated with the output port.
- J. All parameters and waveforms are not applicable to all devices.

Detailed Description

The UM3608 is an 8-bit, dual supply non-inverting bus transceiver. Pin A and direction control pin are support by V_{CCA} and pin B is support by V_{CCB} . The A port is able to accept I/O voltages ranging from 1.65 V to 5.5 V, while the B port can accept I/O voltages from 1.65 V to 5.5 V. The high on DIR allows data transmission from A to B and a low on DIR allows data transmission from B to A.

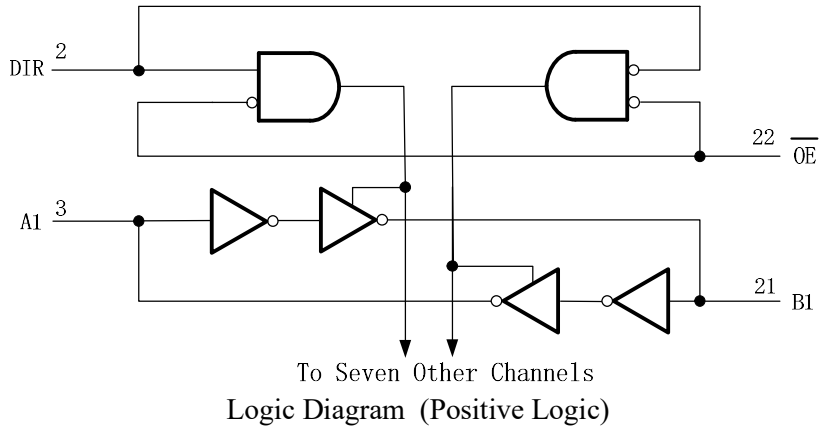
Functional Block Diagram

Feature Description
Fully Configurable Dual-Rail Design Allows Each Port to Operate Over the Full 1.65V to 5.5V Power-Supply Range

Both V_{CCA} and V_{CCB} can be supplied at any voltage between 1.65V and 5.5V making the device suitable for translating between any of the voltage nodes (1.8V, 2.5V, 3.3V and 5V).

 I_{off} Supports Partial-Power-Down Mode Operation

I_{off} prevents backflow current by disabling I/O output circuits when device is in partial-power-down mode.

Device Functional Modes

The UM3608 is bus transceiver that can operate from 1.65V to 5.5V (V_{CCA}) and 1.65V to 5.5V (V_{CCB}). The signal translation between 1.65V and 5.5V requires direction control and output enable control. When OE is low and DIR is high, data transmission is from A to B. When OE is low and DIR is low, data transmission is from B to A. When OE is high, both output ports will be high-impedance.

**Table 1. Function Table(1)
(Each 8-Bit Section)**

CONTROL INPUTS		OUTPUT CIRCUITS		OPERATION
OE	DIR	A PORT	B PORT	
L	L	Enabled	Hi-Z	B data to A bus
L	H	Hi-Z	Enabled	A data to B bus
H	X	Hi-Z	Hi-Z	Isolation

(1) Input circuits of the data I/Os are always active.

Application Information

The UM3608 device can be used in level-translation applications for interfacing devices or systems operating at different interface voltages with one another. The maximum output current can be up to 32 mA when device is powered by 5 V.

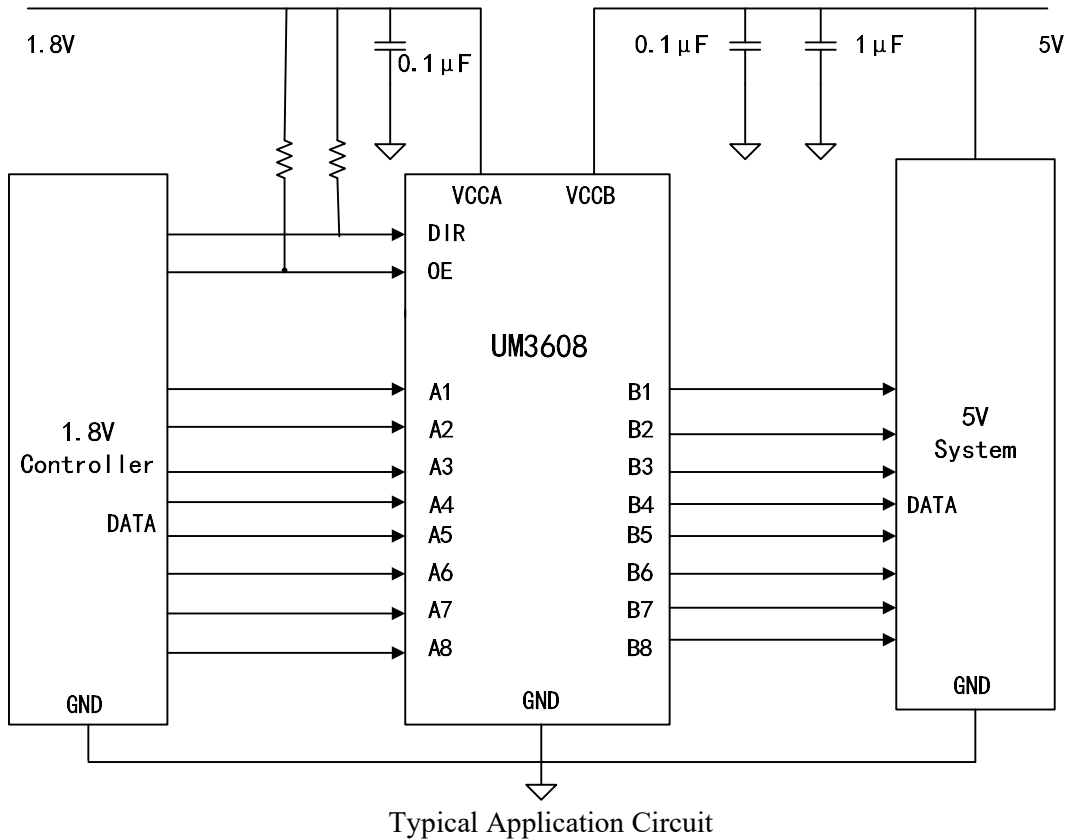

Package Information

UM3608AO SSOP24

Outline Drawing

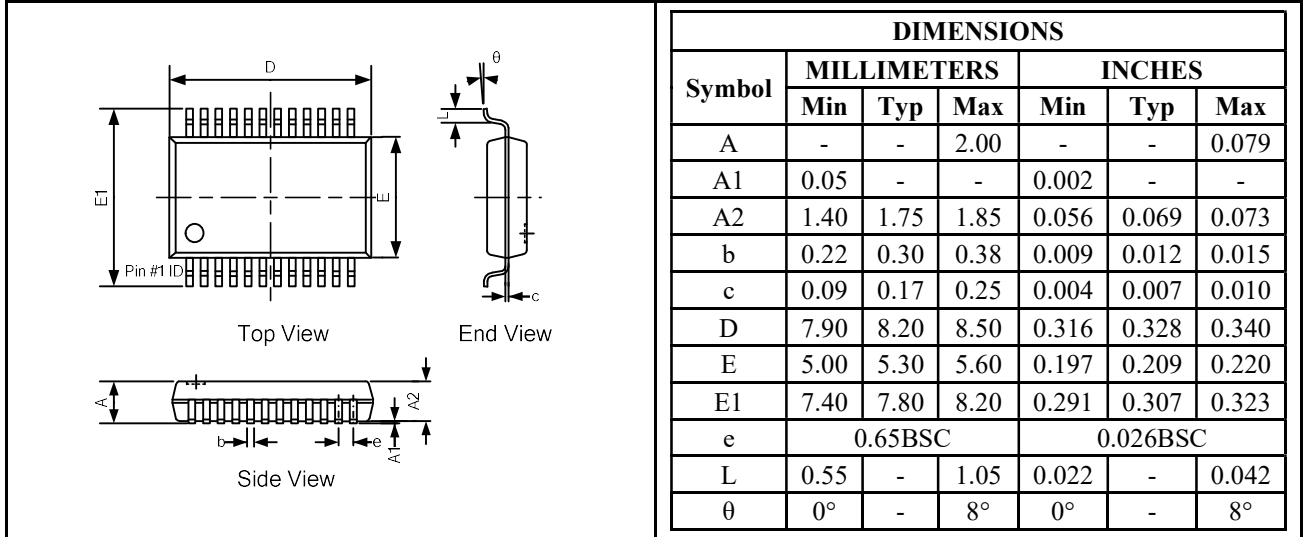

Land Pattern

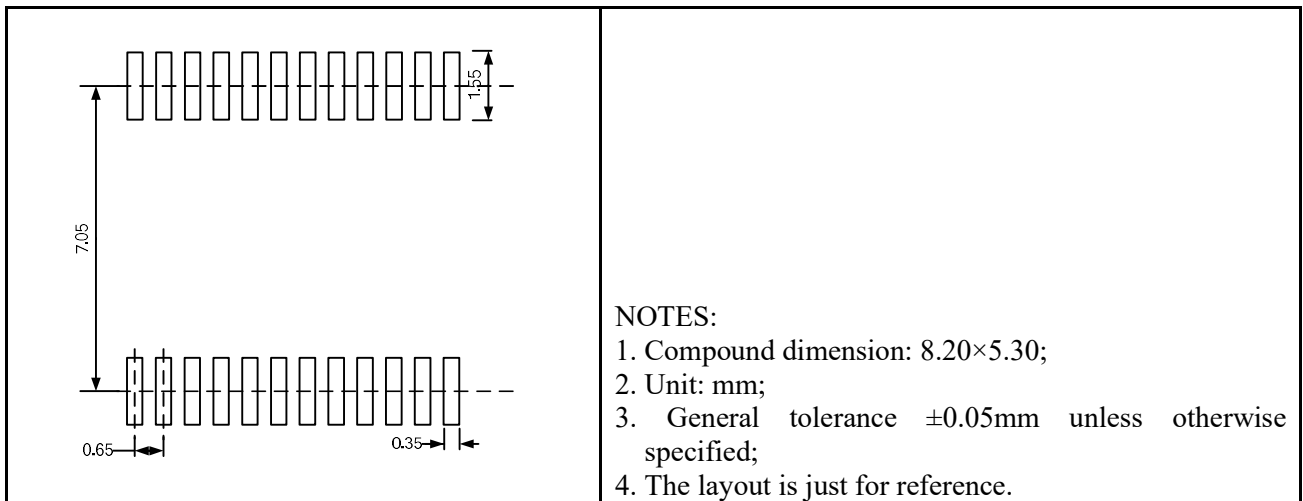

Tape and Reel Orientation



UM3608UO TSSOP24

Outline Drawing

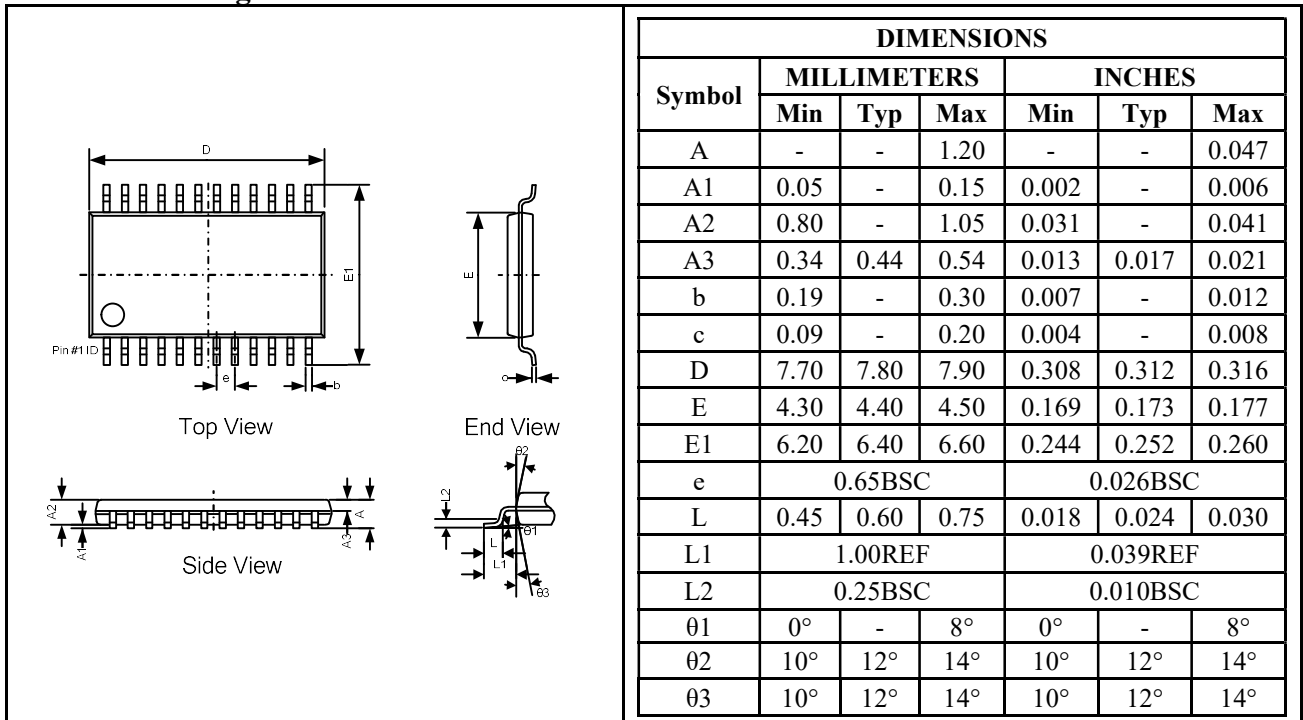

Land Pattern

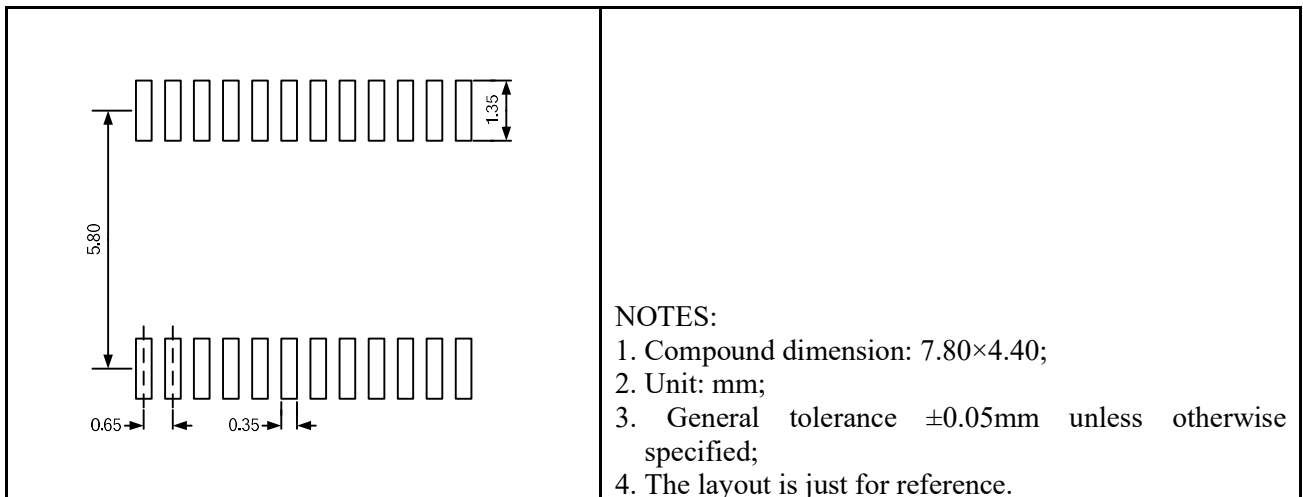

Tape and Reel Orientation



UM3608QA QFN24 3.5×5.5

Outline Drawing

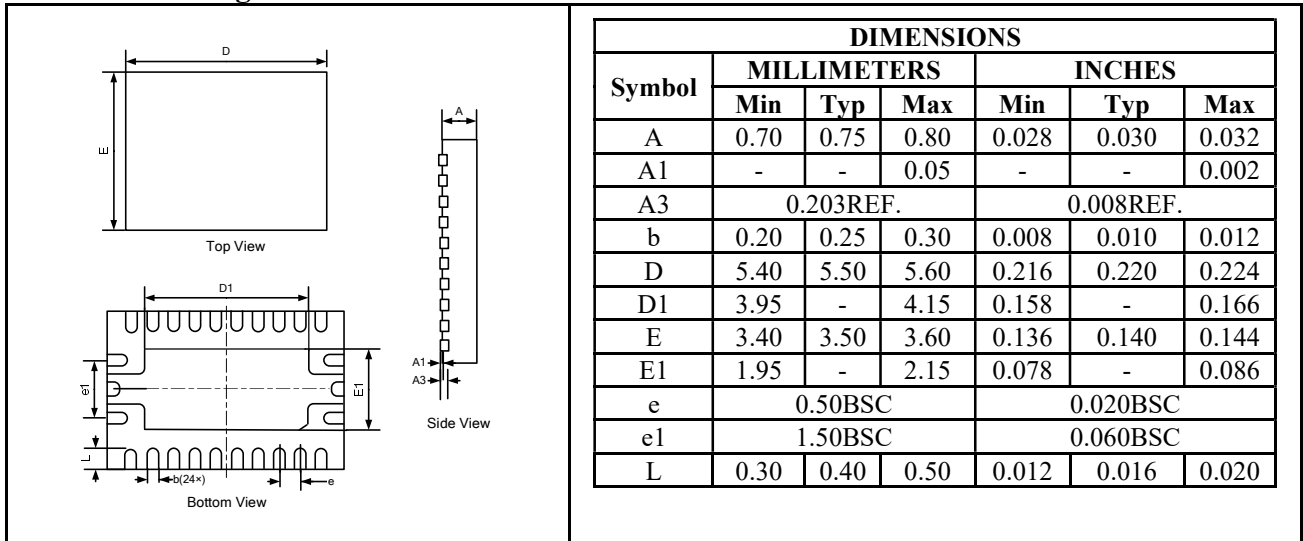

Land Pattern

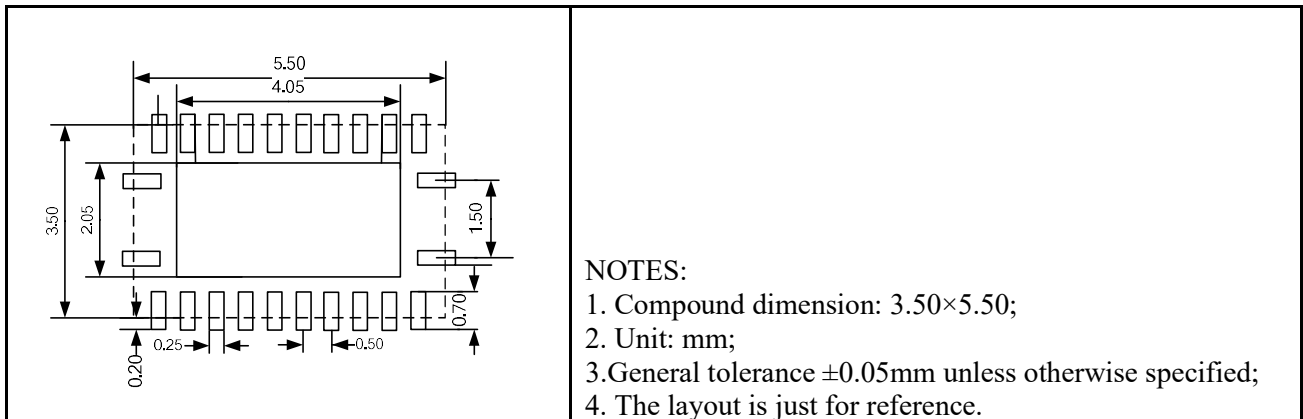

Tape and Reel Orientation

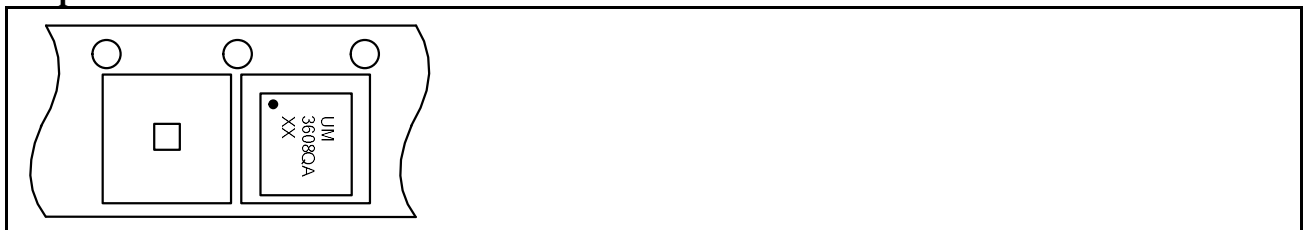

GREEN COMPLIANCE

Union Semiconductor is committed to environmental excellence in all aspects of its operations including meeting or exceeding regulatory requirements with respect to the use of hazardous substances. Numerous successful programs have been implemented to reduce the use of hazardous substances and/or emissions.

All Union components are compliant with the RoHS directive, which helps to support customers in their compliance with environmental directives. For more green compliance information, please visit:

http://www.union-ic.com/index.aspx?cat_code=RoHSDeclaration

IMPORTANT NOTICE

The information in this document has been carefully reviewed and is believed to be accurate. Nonetheless, this document is subject to change without notice. Union assumes no responsibility for any inaccuracies that may be contained in this document, and makes no commitment to update or to keep current the contained information, or to notify a person or organization of any update. Union reserves the right to make changes, at any time, in order to improve reliability, function or design and to attempt to supply the best product possible.



Union Semiconductor, Inc

Add: Unit 606, No.570 Shengxia Road, Shanghai 201210

Tel: 021-51093966

Fax: 021-51026018

Website: www.union-ic.com

X-ON Electronics

Largest Supplier of Electrical and Electronic Components

Click to view similar products for [CAN Interface IC category](#):

Click to view products by [Union manufacturer](#):

Other Similar products are found below :

[PCA82C250T/N4](#) [TLE7251VLE](#) [SIT1051AT/3](#) [TJA1042T](#) [TJA1044T](#) [TJA1040T](#) [TJA1051T/3](#) [TPT1042V-SO1R-S](#) [SCM3425ASA](#)
[NCA1042-DSPR](#) [SIT1057QTK/3](#) [SIT1042AQT/3](#) [SIT1051AQT/3](#) [SIT1044QTK/3](#) [MCP2515-I](#) [TJA1051T](#) [PCA82C251T](#) [MAX3051ESA](#)
[UM3608QA](#) [CA-IF1042VS-Q1](#) [CA-IF1044VS-Q1](#) [HMT1050T](#) [HMT1040T](#) [HGA82C251M/TR](#) [TJA1040M/TR](#) [HG65HVD230M/TR](#)
[TJA1042M-3/TR](#) [PCA82C251M/TR](#) [TDA51SCANHC](#) [TJA1044GT/1](#) [TJA1055T/3/1](#) [SIT1042AQT/3](#) [SIT1051AT](#) [SIT1044QT/3](#)
[SIT1057QT](#) [SIT1042QT](#) [SIT1051QT](#) [SIT1057QT/3](#) [SIT1051AQT/E](#) [SIT1057T/3](#) [SIT1043QTK](#) [SIT1042AT](#) [SIT1042AQT](#) [SIT1042AT/3](#)
[SIT1043QT](#) [SIT1042ATK/3](#) [SIT1057TK/3](#) [SL1040S](#) [SJA1000M/TR](#) [HT82C251ANZ](#)