

4-Pin μ P Voltage Monitors with Manual Reset Input**UM805/811/812 SOT143****General Description**

The UM805/811/812 are low-power microprocessor (μ P) supervisory circuits used to monitor power supplies in μ P and digital systems. They provide excellent circuit reliability and low cost by eliminating external components and adjustments when used with 5V-powered or 3V-powered circuits. The UM805/811/812 also provide a debounced manual reset input.

These devices perform a single function: They assert a reset signal whenever the V_{CC} supply voltage falls below a preset threshold, keeping it asserted for at least 140ms after V_{CC} has risen above the reset threshold. Reset thresholds are available for operation with a variety of supply voltages.

The UM805 has an open-drain output stage, while the UM811/812 have push-pull outputs. The UM805's open-drain $\overline{\text{RESET}}$ output requires a pull-up resistor that can be connected to a voltage higher than V_{CC} . The UM805/811 have an active-low $\overline{\text{RESET}}$ output, while the UM812 has an active-high RESET output. The reset comparator is designed to ignore fast transients on V_{CC} , and the outputs are guaranteed to be in the correct logic state for V_{CC} down to 1V.

Low supply current makes the UM805/811/812 ideal for use in portable equipments. The devices come in a 4-pin SOT143 package.

Applications

- Computers
- Controllers
- Portable/Battery-Powered Equipments
- Intelligent Instruments
- Critical μ P and μ C Power Monitoring

Features

- No External Components
- V_{CC} Transient Immunity
- Correct Logic Output Guaranteed to $V_{CC}=1.0V$
- Precision V_{CC} Monitoring of 3.0V, 3.3V and 5.0V Supplies
- 2 μ A Supply Current
- 140ms Minimum Power-On Reset Pulse Width
- Guaranteed Over Temperature
- Available in 3 Output Configurations:
Open-Drain Active-Low $\overline{\text{RESET}}$ Output (UM805)
Push-Pull Active-Low $\overline{\text{RESET}}$ Output (UM811)
Push-Pull Active-High RESET Output (UM812)
- 4-Pin SOT143 Package
- Wide Operation Temperature: -40°C to +85°C

Pin Configurations

Top View

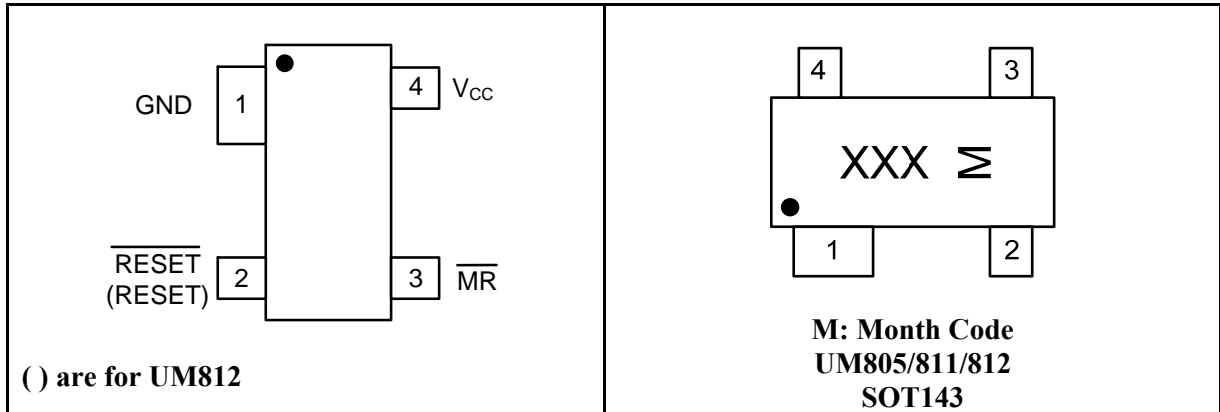

Ordering Information

UM8 XX Z P

XX: Output Type

=05 Open-Drain Active Low

=11 Push-Pull Active Low

=12 Push-Pull Active High

Z: Reset Threshold (V)

=L 4.63

=M 4.38

=J 4.00

=T 3.08

=S 2.93

=R 2.63

=Z 2.32

P: Package Type

=E SOT143

Typical Operating Circuit

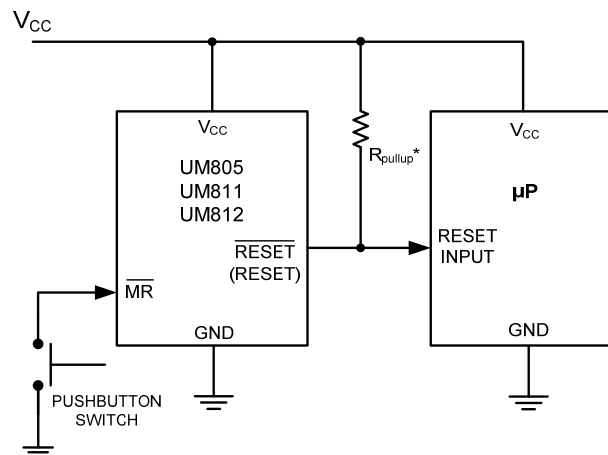

*UM805 ONLY
() are for UM812

Pin Description

Pin Number	Pin Name	Function
1	GND	Ground
2	$\overline{\text{RESET}}$ (UM805/811)	Active-Low Reset Output. $\overline{\text{RESET}}$ remains low while V_{CC} is below the reset threshold or while $\overline{\text{MR}}$ is held low. It remains low for the Reset Active Timeout Period (t_{RP}) after the reset conditions are terminated. See Figure 1. UM811: CMOS push-pull output (sources and sinks current). UM805: Open-drain, active low, NMOS output (sinks current only). Connect a pull-up resistor from $\overline{\text{RESET}}$ to any supply voltage up to 6V.
	RESET (UM812)	Active-High Reset Output. RESET remains high while V_{CC} is below the reset threshold or while $\overline{\text{MR}}$ is held low. RESET remains high for Reset Active Timeout Period (t_{RP}) after the reset conditions are terminated.
3	$\overline{\text{MR}}$	Manual Reset Input. A logic low on $\overline{\text{MR}}$ asserts reset. Reset remains asserted as long as $\overline{\text{MR}}$ is low and for 240ms after $\overline{\text{MR}}$ returns high. This active-low input has an internal 20k Ω pull-up resistor. It can be driven from a TTL or CMOS-logic line, or shorted to ground with a switch. Leave open if unused. See Figure 2.
4	V_{CC}	+5V, +3.3V or +3V Supply Voltage

Absolute Maximum Ratings (Note 1)

Symbol	Parameter	Value	Unit
V_{CC}	Supply Voltage	-0.3 to +6.0	V
	RESET, $\overline{\text{RESET}}$ (Push-Pull)	-0.3 to ($V_{CC}+0.3$)	
	$\overline{\text{RESET}}$ (Open-Drain)	-0.3 to +6.0	
I_{CC}	Input Current, V_{CC} , $\overline{\text{MR}}$	20	mA
I_O	Output Current, RESET, $\overline{\text{RESET}}$	20	mA
P_D	Continuous Power Dissipation (Derate 4mW/°C above 70°C)	320	mW
T_A	Operating Temperature Range	-40 to +105	°C
T_{STG}	Storage Temperature Range	-65 to +160	°C
	Lead Temperature (Soldering, 10s)	+300	°C

Note 1: Stresses beyond those listed under “Absolute maximum Ratings” may cause permanent damage to the device. These are stress ratings only and functional operation of the device at these or any other conditions beyond those indicated in the operational sections of the specifications are not implied. Exposure to absolute maximum rating conditions for extended periods may affect device reliability.

Electrical Characteristics

($V_{CC}=5V$ for L/M/J versions, $V_{CC}=3.3V$ for T/S versions, $V_{CC}=3V$ for R version, and $V_{CC}=2.5V$ for Z version, $T_A=-40^{\circ}C$ to $+85^{\circ}C$, unless otherwise noted. Typical values are at $T_A=+25^{\circ}C$.) (Note 2)

Symbol	Parameter	Conditions	Min	Typ	Max	Unit	
V_{CC}	Supply Voltage Range	$T_A=0^{\circ}C$ to $+70^{\circ}C$	1.0		5.5	V	
I_{CC}	Supply Current			2.0	5.0	μA	
V_{TH+}	Reset Threshold	L Version	$T_A=+25^{\circ}C$	4.56	4.63	4.70	V
			$T_A=-40^{\circ}C$ to $+85^{\circ}C$	4.50		4.75	
		M Version	$T_A=+25^{\circ}C$	4.31	4.38	4.45	
			$T_A=-40^{\circ}C$ to $+85^{\circ}C$	4.25		4.50	
		J Version	$T_A=+25^{\circ}C$	3.93	4.00	4.06	
			$T_A=-40^{\circ}C$ to $+85^{\circ}C$	3.89		4.10	
		T Version	$T_A=+25^{\circ}C$	3.04	3.08	3.11	
			$T_A=-40^{\circ}C$ to $+85^{\circ}C$	3.00		3.15	
		S Version	$T_A=+25^{\circ}C$	2.89	2.93	2.96	
			$T_A=-40^{\circ}C$ to $+85^{\circ}C$	2.85		3.00	
		R Version	$T_A=+25^{\circ}C$	2.59	2.63	2.66	
			$T_A=-40^{\circ}C$ to $+85^{\circ}C$	2.55		2.70	
		Z Version	$T_A=+25^{\circ}C$	2.28	2.32	2.35	
			$T_A=-40^{\circ}C$ to $+85^{\circ}C$	2.25		2.38	
	Reset Threshold Tempco			150		ppm/ $^{\circ}C$	
	V_{CC} to Reset Delay (Note 3)			10		μs	
t_{RP}	Reset Active Timeout Period		140	240	560	ms	
t_{MR}	\overline{MR} Minimum Pulse Width		10			μs	
	\overline{MR} Glitch Immunity (Note 4)			100		ns	
t_{MD}	\overline{MR} to Reset Propagation Delay			0.5		μs	
V_{IH}	\overline{MR} Input Threshold	$V_{CC}>V_{TH(MAX)}$ UM805/811/812LE/ME/JE	2.3			V	
V_{IL}					0.8		
V_{IH}		$V_{CC}>V_{TH(MAX)}$ UM805/811/812TE/SE/RE/ZE	$0.7 \times V_{CC}$				
V_{IL}					$0.25 \times V_{CC}$		
	\overline{MR} Pull-Up Resistance		10	20	30	k Ω	

Electrical Characteristics (Continued)

($V_{CC}=5V$ for L/M/J versions, $V_{CC}=3.3V$ for T/S versions, $V_{CC}=3V$ for R version, and $V_{CC}=2.5V$ for Z version, $T_A=-40^{\circ}C$ to $+85^{\circ}C$, unless otherwise noted. Typical values are at $T_A=+25^{\circ}C$.) (Note 2)

Symbol	Parameter	Conditions	Min	Typ	Max	Unit	
V_{OH}	RESET Output Voltage	$I_{SOURCE}=150\mu A$, $1.8V < V_{CC} < V_{TH(MIN)}$ UM812LE/ME/JE/TE/SE/RE/ZE	$0.8 \times V_{CC}$			V	
V_{OL}		$I_{SINK}=1.2mA$ UM812TE/SE/RE/ZE			0.3		
		$I_{SINK}=3.2mA$ UM812LE/ME/JE			0.4		
V_{OH}	RESET Output Voltage	$I_{SOURCE}=500\mu A$, $V_{CC} > V_{TH(MAX)}$ UM811TE/SE/RE/ZE	$0.8 \times V_{CC}$			V	
		$I_{SOURCE}=800\mu A$, $V_{CC} > V_{TH(MAX)}$ UM811LE/ME/JE	$V_{CC}-1.5$				
V_{OL}		$I_{SINK}=1.2mA$, $V_{CC}=V_{TH(MIN)}$ UM805/811TE/SE/RE/ZE					0.3
		$I_{SINK}=3.2mA$, $V_{CC}=V_{TH(MIN)}$ UM805/811LE/ME/JE					0.4
		$I_{SINK}=50\mu A$, $V_{CC} > 1.0V$					0.3

Note 2: Production testing done at $T_A=+25^{\circ}C$; limits over temperature guaranteed by design only.

Note 3: RESET output for UM805/811; RESET output for UM812.

Note 4: "Glitches" of 100ns or less typically will not generate a reset pulse.

Typical Operating Characteristics

($T_A=+25^\circ\text{C}$, unless otherwise noted.)

Supply Current vs. Temperature
(UM811RE)

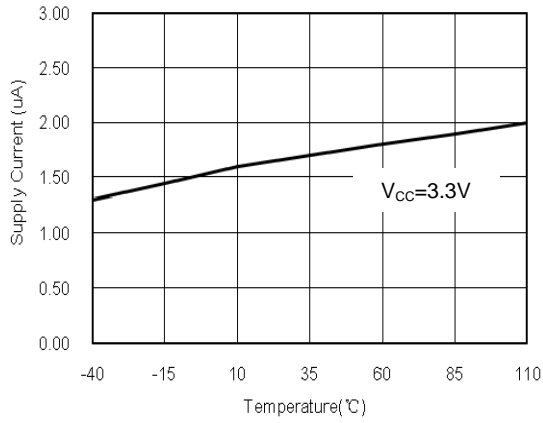

Power-down RESET Delay vs. Temperature
(UM811RE)

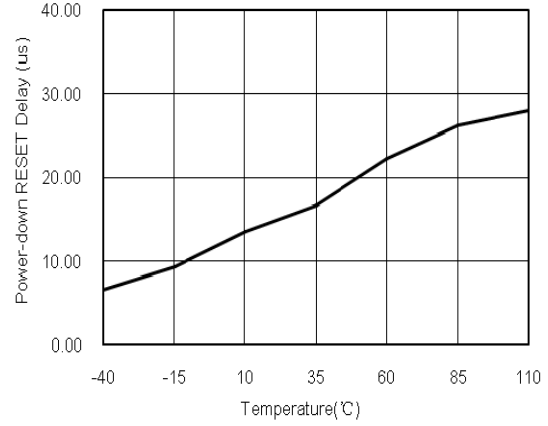

Power-up RESET Timeout vs. Temperature

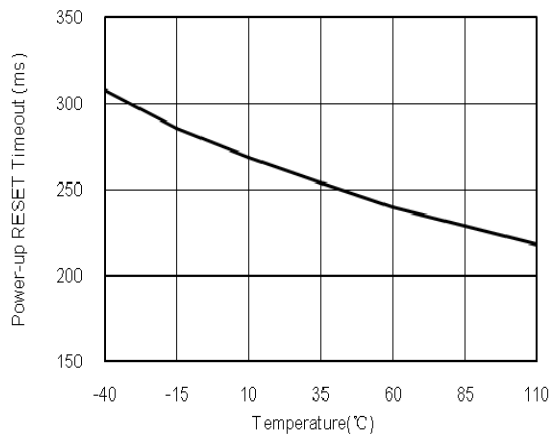

Detailed Description

RESET Timing

The reset signal is asserted LOW for the UM811 and HIGH for the UM812 when the power supply voltage falls below the threshold trip voltage and remains asserted for at least 140ms after the power supply voltage has risen above the threshold.

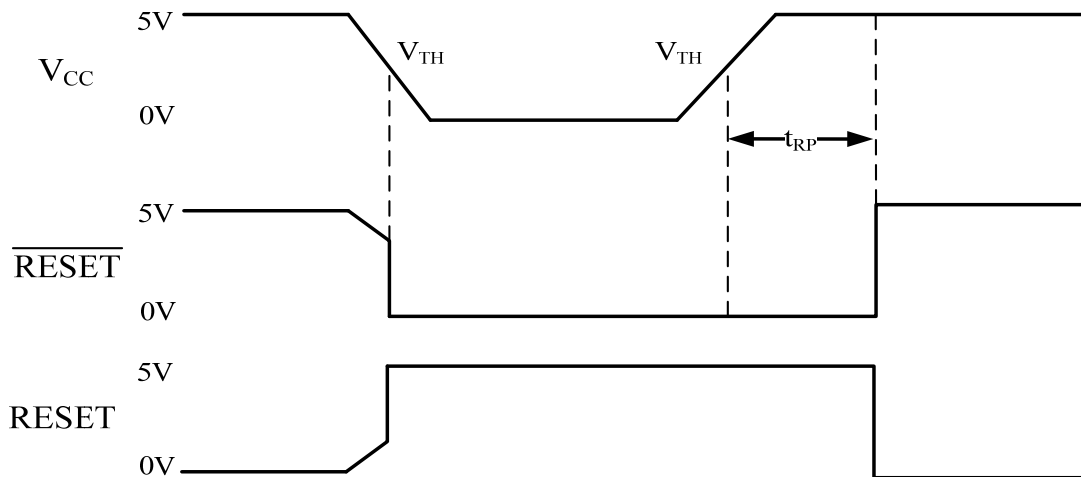

Figure 1. RESET vs. V_{CC} Timing Diagram

The reset signal is asserted LOW for the UM811 and HIGH for the UM812 when \overline{MR} is low and remains asserted for at least 140ms after \overline{MR} is high.

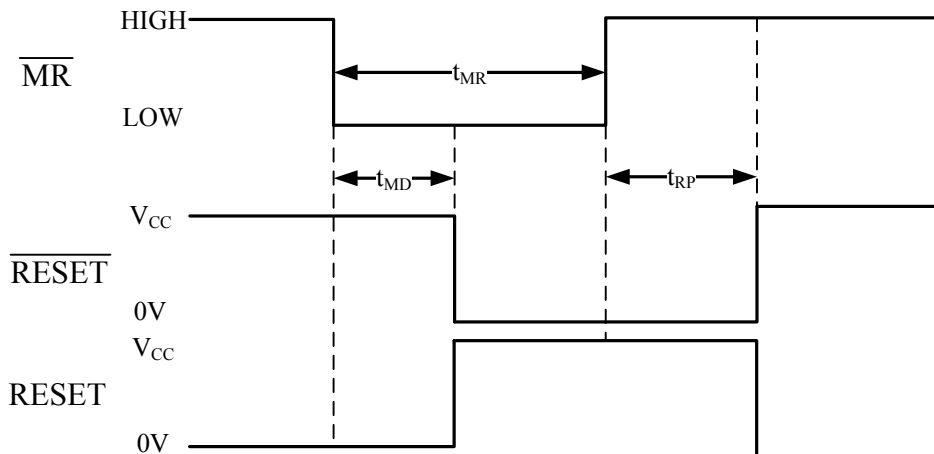

Figure 2. RESET vs. \overline{MR} Timing Diagram

Reset Output

A microprocessor's (μP 's) reset input starts the μP in a known state. These μP supervisory circuits assert reset to prevent code execution errors during power-up, power-down, or brownout conditions. \overline{RESET} is guaranteed to be a logic low for $V_{CC} > 1V$. Once V_{CC} exceeds the reset threshold, an internal timer keeps \overline{RESET} low for the reset timeout period; after this interval, \overline{RESET} goes high.

If a brownout condition occurs (V_{CC} dips below the reset threshold), \overline{RESET} goes low. Any time

V_{CC} goes below the reset threshold, the internal timer resets to zero, and $\overline{\text{RESET}}$ goes low. The internal timer starts after V_{CC} returns above the reset threshold, and $\overline{\text{RESET}}$ remains low for the reset timeout period.

The manual reset input ($\overline{\text{MR}}$) can also initiate a reset. See the *Manual Reset Input* section.

The UM812 has an active-high RESET output that is the inverse of the UM805/811's $\overline{\text{RESET}}$ output. The UM805 uses an open-drain output, and the UM811/812 have a push-pull output stage. Connect a pull-up resistor on the UM805's $\overline{\text{RESET}}$ output to any supply between 0 and 6V.

Manual Reset Input

Many μP -based products require manual reset capability, allowing the operator, a test technician, or external logic circuitry to initiate a reset. A logic low on $\overline{\text{MR}}$ asserts reset. Reset remains asserted while $\overline{\text{MR}}$ is low, and for the Reset Active Timeout Period (t_{RP}) after $\overline{\text{MR}}$ returns high. This input has an internal 20k Ω pull-up resistor, so it can be left open if it is not used. $\overline{\text{MR}}$ can be driven with TTL or CMOS-logic levels, or with open-drain/collector outputs. Connect a normally open momentary switch from $\overline{\text{MR}}$ to GND to create a manual-reset function; external debounce circuitry is not required. If $\overline{\text{MR}}$ is driven from long cables or if the device is used in a noisy environment, connecting a 0.1 μF capacitor from $\overline{\text{MR}}$ to ground provides additional noise immunity.

Reset Threshold Accuracy

The UM805/811/812 are ideal for systems using a 5V \pm 5% or 3V \pm 5% power supply with ICs specified for 5V \pm 10% or 3V \pm 10%, respectively. They are designed to meet worst-case specifications over temperature. The reset is guaranteed to assert after the power supply falls out of regulation, but before power drops below the minimum specified operating voltage range for the system ICs. The thresholds are pre-trimmed and exhibit tight distribution, reducing the range over which an undesirable reset may occur.

Applications Information

Negative-Going V_{CC} Transients

In addition to issuing a reset to the μP during power-up, power-down, and brownout conditions, the UM805/811/812 are relatively immune to short-duration negative-going V_{CC} transients (glitches). Figure 3 shows typical transient duration vs. reset comparator overdrive, for which the UM805/811/812 do not generate a reset pulse. The graph was generated using a negative-going pulse applied to V_{CC} , starting above the actual reset threshold and ending below it by the magnitude indicated (reset comparator overdrive). The graph indicates the typical maximum pulse width a negative-going V_{CC} transient may have without causing a reset pulse to be issued. As the magnitude of the transient increases (goes farther below the reset threshold), the maximum allowable pulse width decreases. Typically, for the UM8__LE/ME/JE, a V_{CC} transient that goes 125mV below the reset threshold and lasts 40 μs or less will not cause a reset pulse to be issued. A 0.1 μF capacitor mounted as close as possible to the V_{CC} provides additional transient immunity.

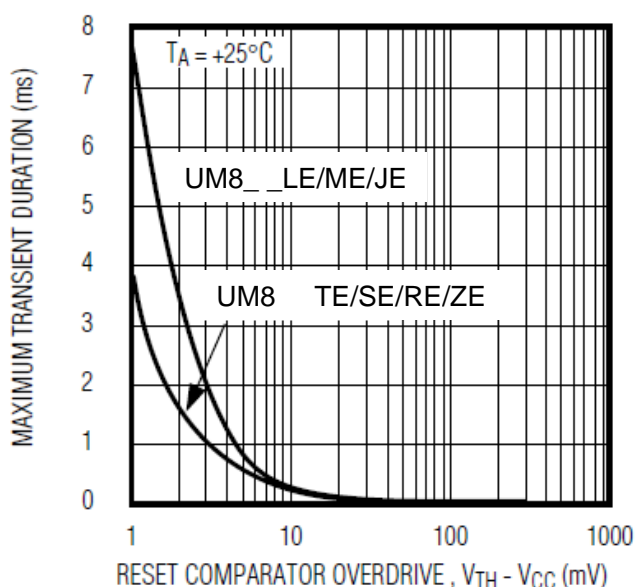

Figure 3. Maximum Transient Duration without Causing a Reset Pulse vs. Reset Comparator Overdrive

Ensuring a Valid \overline{RESET} Output Down to $V_{CC}=0V$

When V_{CC} falls below 1V, the UM811 \overline{RESET} output no longer sinks current—it becomes an open circuit. Therefore, high-impedance CMOS-logic inputs connected to \overline{RESET} can drift to undetermined voltages. This presents no problem in most applications since most μP and other circuitry is inoperative with V_{CC} below 1V. However, in applications where \overline{RESET} must be valid down to 0V, adding a pull-down resistor to \overline{RESET} pin will cause any stray leakage currents to flow to ground, holding \overline{RESET} low (Figure 4). $R1$'s value is not critical; 100k Ω is large enough not to load \overline{RESET} and small enough to pull \overline{RESET} to ground.

A 100k Ω pull-up resistor to V_{CC} is also recommended for the UM812 if \overline{RESET} is required to remain valid for $V_{CC} < 1V$.

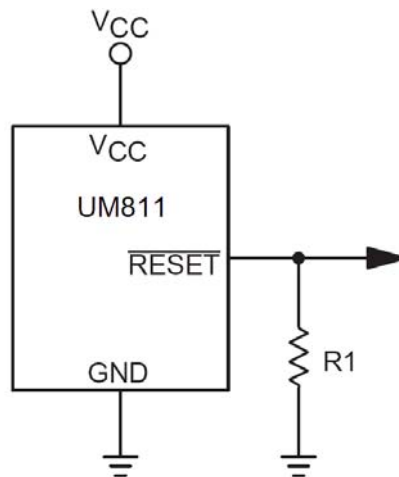

Figure 4. $\overline{\text{RESET}}$ Valid to $V_{CC}=\text{Ground}$ Circuit

Interfacing to μPs with Bidirectional Reset Pins

μPs with bidirectional reset pins (such as the Motorola68HC11 series) can contend with the UM811/812 reset outputs. If, for example, the UM811 $\overline{\text{RESET}}$ output is asserted high and the μP wants to pull it low, indeterminate logic levels may result. To correct such cases, connect a 4.7k Ω resistor between the UM811 $\overline{\text{RESET}}$ (or UM812 $\overline{\text{RESET}}$) output and the μP reset I/O (Figure 5). Buffer the reset output to other system components.

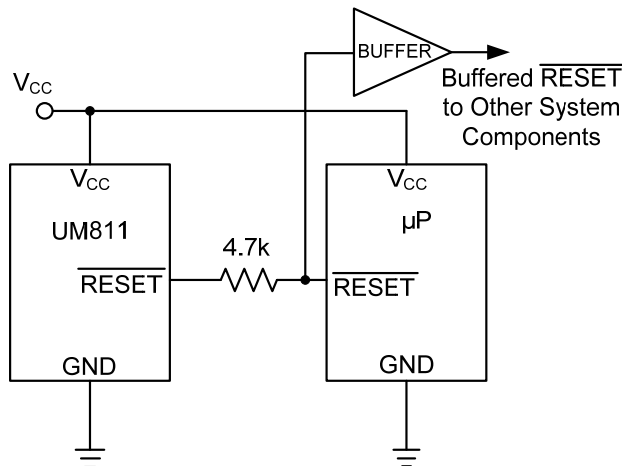

Figure 5. Interfacing to μPs with Bidirectional Reset I/O

UM805 Open-Drain $\overline{\text{RESET}}$ Output Allows Use with Multiple Supplies

Generally, the pull-up connected to the UM805 will connect to the supply voltage that is being monitored at the IC's V_{CC} pin. However, some systems may use the open-drain output to level-shift from the monitored supply to reset circuitry powered by some other supply (Figure 6). Note that as the UM805's V_{CC} decreases below 1V, so does the IC's ability to sink current at $\overline{\text{RESET}}$. Also, with any pull-up, $\overline{\text{RESET}}$ will be pulled high as V_{CC} decays toward 0. The voltage where this occurs depends on the pull-up resistor value and the voltage to which it is connected.

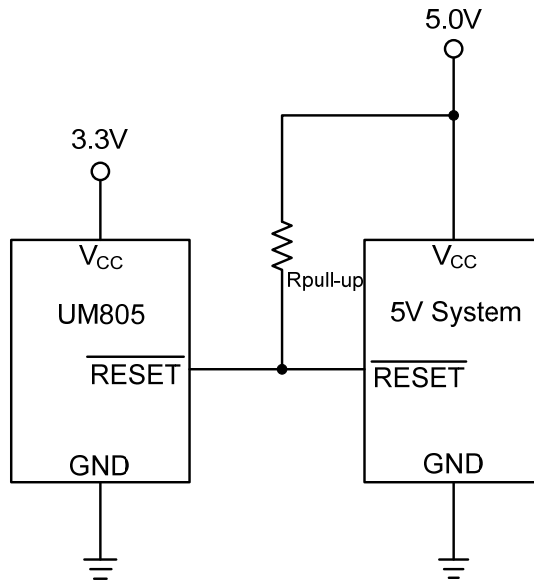
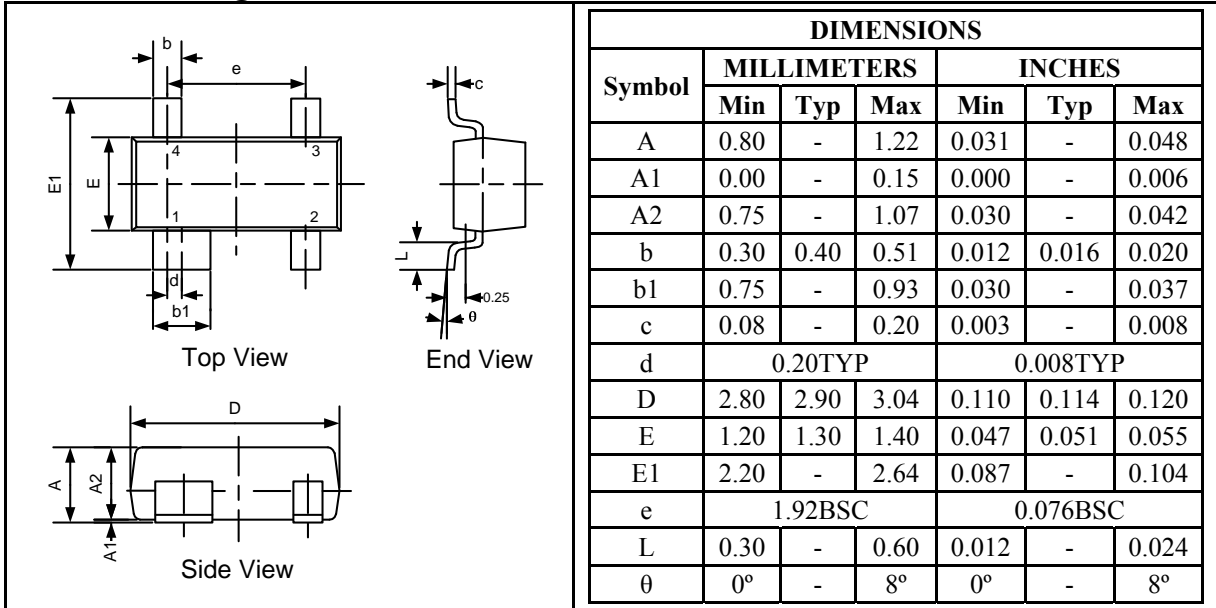

Figure 6. UM805 Open-Drain $\overline{\text{RESET}}$ Output Allows Use with Multiple Supplies

Package Information

UM805/811/812 SOT143

Outline Drawing



Land Pattern

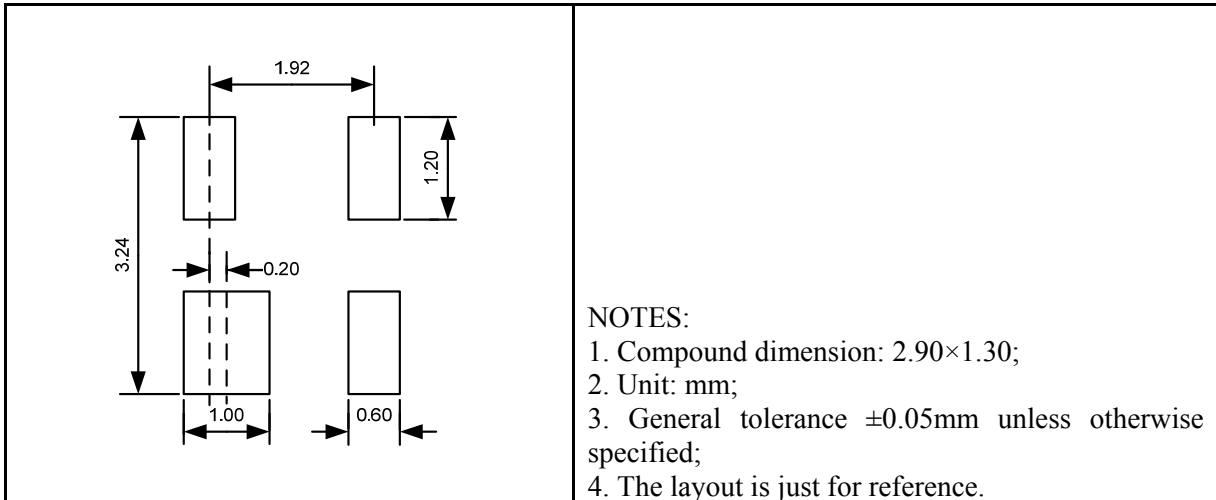

Tape and Reel Orientation

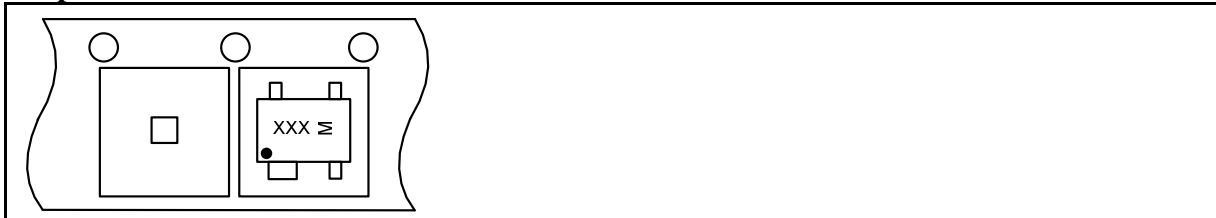

Selection Table

Part Number	RESET Threshold (V)	Timeout Period (ms)	Output Type	Marking Code	Package Type	Shipping Qty
UM805LE	4.63	240	Open-Drain, Active Low	05L	SOT143	3000pcs/7Inch Tape & Reel
UM805ME	4.38	240	Open-Drain, Active Low	05M		
UM805JE	4.00	240	Open-Drain, Active Low	05J		
UM805TE	3.08	240	Open-Drain, Active Low	05T		
UM805SE	2.93	240	Open-Drain, Active Low	05S		
UM805RE	2.63	240	Open-Drain, Active Low	05R		
UM805ZE	2.32	240	Open-Drain, Active Low	05Z		
UM811LE	4.63	240	Push-Pull, Active Low	11L		
UM811ME	4.38	240	Push-Pull, Active Low	11M		
UM811JE	4.00	240	Push-Pull, Active Low	11J		
UM811TE	3.08	240	Push-Pull, Active Low	11T		
UM811SE	2.93	240	Push-Pull, Active Low	11S		
UM811RE	2.63	240	Push-Pull, Active Low	11R		
UM811ZE	2.32	240	Push-Pull, Active Low	11Z		
UM812LE	4.63	240	Push-Pull, Active High	12L		
UM812ME	4.38	240	Push-Pull, Active High	12M		
UM812JE	4.00	240	Push-Pull, Active High	12J		
UM812TE	3.08	240	Push-Pull, Active High	12T		
UM812SE	2.93	240	Push-Pull, Active High	12S		
UM812RE	2.63	240	Push-Pull, Active High	12R		
UM812ZE	2.32	240	Push-Pull, Active High	12Z		

GREEN COMPLIANCE

Union Semiconductor is committed to environmental excellence in all aspects of its operations including meeting or exceeding regulatory requirements with respect to the use of hazardous substances. Numerous successful programs have been implemented to reduce the use of hazardous substances and/or emissions.

All Union components are compliant with the RoHS directive, which helps to support customers in their compliance with environmental directives. For more green compliance information, please visit:

http://www.union-ic.com/index.aspx?cat_code=RoHSDeclaration

IMPORTANT NOTICE

The information in this document has been carefully reviewed and is believed to be accurate. Nonetheless, this document is subject to change without notice. Union assumes no responsibility for any inaccuracies that may be contained in this document, and makes no commitment to update or to keep current the contained information, or to notify a person or organization of any update. Union reserves the right to make changes, at any time, in order to improve reliability, function or design and to attempt to supply the best product possible.



Union Semiconductor, Inc

Add: Unit 606, No.570 Shengxia Road, Shanghai 201210

Tel: 021-51093966

Fax: 021-51026018

Website: www.union-ic.com

X-ON Electronics

Largest Supplier of Electrical and Electronic Components

Click to view similar products for [Supervisory Circuits](#) category:

Click to view products by [Union manufacturer](#):

Other Similar products are found below :

[CAT1161LI-25-G](#) [CAT853STBI-T3](#) [TC54VN2402EMB713](#) [MCP1316T-44NE/OT](#) [MCP1316MT-45GE/OT](#) [MCP1316MT-23LI/OT](#)
[DS1232L](#) [NCV302HSN45T1G](#) [MCP1316T-23LI/OT](#) [PT7M6130NLTA3EX](#) [S-1000N28-I4T1U](#) [CAT1161LI-28-G](#) [MCP1321T-29AE/OT](#)
[MCP1319MT-47QE/OT](#) [S-1000N23-I4T1U](#) [S-1000N19-I4T1U](#) [CAT824UTDI-GT3](#) [TC54VC2502ECB713](#) [PT7M6133NLTA3EX](#)
[PT7M6127NLTA3EX](#) [BD48E23G-TR](#) [BD48E49G-TR](#) [BD48E52G-TR](#) [MP6412GQGU-Z](#) [XC61GN2502HR-G](#) [HG810RM3/TR](#)
[ME2808A33XG](#) [ME2801A33M3G](#) [HT7033S](#) [UM803RS](#) [UM805RE](#) [XC61CC1502MR](#) [XC61CN1802MR](#) [BL8509CCB3TR263DC](#)
[BL8506-33CRM](#) [BL8506-45CRM](#) [CL7809RS](#) [CL7809TS](#) [MB3793-37APNF-G-JN-ER6E1](#) [CPC5712U](#) [LTC693CSW](#) [TC1232EOE](#)
[TC1270ALVRCTR](#) [TC1271MERCCTR](#) [TC32MEZB](#) [TC54VC4202EMB713](#) [TC54VN2102ECB713](#) [MB3793-27DPNF-G-JN-ERE1](#) [MCP100-475HI/TO](#) [MCP100-485DI/TO](#)