

Contents

	Page
Introduction	
1.0 Scope	4
2.0 Ratings & Dimension	4~5
3.0 Structure.....	5
4.0 Marking.....	6~7
5.0 Derating Curve.....	8
6.0 Performance Specification	8~9
7.0 Explanation of Part No. System	10
8.0 Ordering Procedure	11
9.0 Packing	11~13
10.0 Note Matter.....	14

File Name: CHIP SERIES $\pm 0.5\%, \pm 1\%, \pm 2\%, \pm 5\% \& 0 \Omega$	Date	2016.02.29	Edition No.	1
---	------	------------	-------------	---

Amendment Record			Signature	
------------------	--	--	-----------	--

Edition	Prescription of amendment	Amend Page	Amend Date	Amended by	Checked by

1.0 Scope:

This specification for approve relates to the Lead-Free Thick Film Chip Resistors manufactured by ROYALOHM.

2.0 Ratings & Dimension:

01005, 0201, 0402	0603, 0805, 1206, 1210, 1812, 2010, 2512

2.1 Dimension & Resistance Range :

Type	70°C Power	Dimension(mm)					Resistance Range			
		L	W	H	A	B	0.5%	1.0%	2.0%	5.0%
01005	1/32W	0.40±0.02	0.20±0.02	0.13±0.02	0.10±0.05	0.10±0.03	--	10Ω-10MΩ	10Ω-10MΩ	1Ω-10MΩ
0201	1/20W	0.60±0.03	0.30±0.03	0.23±0.03	0.10±0.05	0.15±0.05	--	1Ω-10MΩ	1Ω-10MΩ	1Ω-10MΩ
0402	1/16W	1.00±0.10	0.50±0.05	0.35±0.05	0.20±0.10	0.25±0.10	1Ω-10MΩ	0.1Ω~22MΩ	0.1Ω~22MΩ	0.1Ω~22MΩ
0603	1/16W 1/10WS	1.60±0.10	+0.15 0.80 -0.10	0.45±0.10	0.30±0.20	0.30±0.20	1Ω-10MΩ	0.1Ω~33MΩ	0.1Ω~33MΩ	0.1Ω~100MΩ
0805	1/10W 1/8WS	2.00±0.15	+0.15 1.25 -0.10	0.55±0.10	0.40±0.20	0.40±0.20	1Ω-10MΩ	0.1Ω~33MΩ	0.1Ω~33MΩ	0.1Ω~100MΩ
1206	1/8W 1/4WS	3.10±0.15	+0.15 1.55 -0.10	0.55±0.10	0.45±0.20	0.45±0.20	1Ω-10MΩ	0.1Ω~33MΩ	0.1Ω~33MΩ	0.1Ω~100MΩ
1210	1/4W 1/3WS 1/2WSS	3.10±0.10	2.60±0.20	0.55±0.10	0.50±0.25	0.50±0.20	1Ω-10MΩ	0.1Ω~10MΩ	0.1Ω~22MΩ	0.1Ω~100MΩ
1812	1/2W 3/4WS	4.50±0.20	3.20±0.20	0.55±0.20	0.50±0.20	0.50±0.20	1Ω-10MΩ	0.1Ω-10MΩ	0.1Ω-10MΩ	0.1Ω-10MΩ
2010	1/2W 3/4WS	5.00±0.10	2.50±0.20	0.55±0.10	0.60±0.25	0.50±0.20	1Ω-10MΩ	0.1Ω~22MΩ	0.1Ω~22MΩ	0.1Ω~22MΩ
2512	1W	6.35±0.10	3.20±0.20	0.55±0.10	0.60±0.25	0.50±0.20	1Ω-10MΩ	0.1Ω~33MΩ	0.1Ω~33MΩ	0.1Ω~33MΩ

2.2 Ratings

Type	70°C Power	Max. Working Voltage	Max. Overload Voltage	Dielectric withstanding Voltage	Resistance Value of Jumper	Rated Current of Jumper	Max. Rated Current of Jumper	Operating Temperature
01005	1/32W	15V	30V	--	<50mΩ	--	--	-55°C~155°C
0201	1/20W	25V	50V	--	<50mΩ	0.5A	1A	-55°C~155°C
0402	1/16W	50V	100V	100V	<50mΩ	1A	2A	-55°C~155°C
0603	1/16W 1/10WS	75V	150V	300V	<50mΩ	1A	2A	-55°C~155°C
0805	1/10W 1/8WS	150V	300V	500V	<50mΩ	2A	5A	-55°C~155°C
1206	1/8W 1/4WS	200V	400V	500V	<50mΩ	2A	10A	-55°C~155°C
1210	1/4W 1/3WS 1/2WSS	200V	500V	500V	<50mΩ	2A	10A	-55°C~155°C
1812	1/2W 3/4WS	200V	500V	500V	<50mΩ	2A	10A	-55°C~155°C
2010	1/2W 3/4WS	200V	500V	500V	<50mΩ	2A	10A	-55°C~155°C
2512	1W	200V	500V	500V	<50mΩ	2.5A	10A	-55°C~155°C

3.0 Structure:

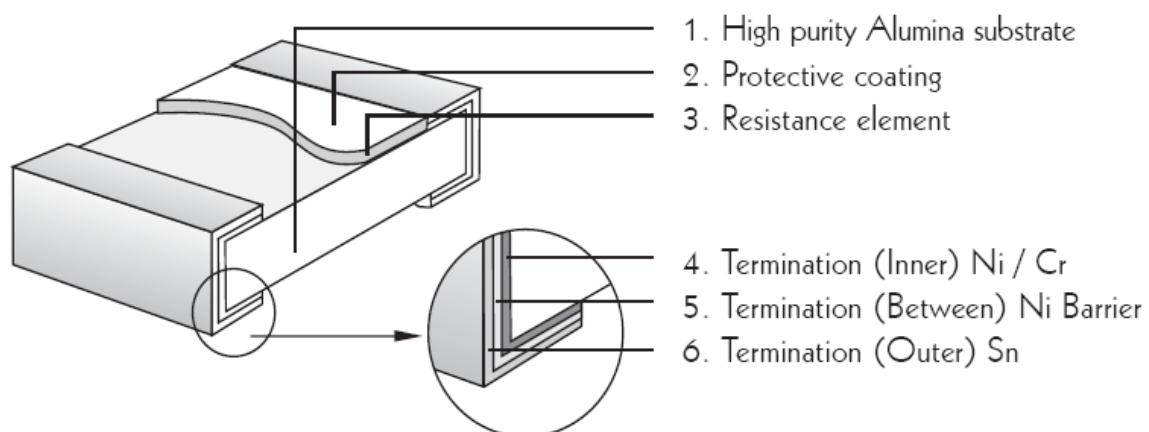

4.0 Marking:

(1) For 01005、0201 and 0402 size. Due to the very small size of the resistor's body, there is no marking on the body.

Example:



01005、0201、0402

(2) ±2%,±5%Tolerance:The first two digits are significant figures of resistance and the third denotes number of zeros following

Example:



333 → 33KΩ

(3) ±2%、±5%Tolerance: Below 10Ω show as following, read alphabet"R" as decimal point.

Example:



2R2 → 2.2Ω

(4) ±0.5%、±1% Tolerance: 4 digits, first three digits are significant; forth digit is number of zeros. Letter r is decimal point.



2701 → 2.7KΩ



10R0 → 10Ω

(5) standard E-24 and not belong to E-96 series values(in ±0.5%、±1%tolerance)of 0603 size the marking is the same as 5% tolerance but marking as underline



333 → 33KΩ



680 → 68Ω

(6) Standard E-96 series values (±0.5%、±1% tolerance) of 0603 size. Due the small size of the resistor's body, 3 digits marking will be used to indicate the accurate resistance value by using the following multiplier & resistance code.

Multiplier code:

Code	A	B	C	D	E	F	G	H	X	Y	Z
Multiplier	10 ⁰	10 ¹	10 ²	10 ³	10 ⁴	10 ⁵	10 ⁶	10 ⁷	10 ⁻¹	10 ⁻²	10 ⁻³

Coding formula

First two digits-----Resistance code Third digit-----Multiplier code

EXAMPLE: 1.96KΩ=196×10¹Ω-----29B

12.4Ω=124×10⁻¹Ω-----10X



STANDARD E-96 VALUES AND 0603 RESISTANCE CODE

Ω VALUE	CODE	Ω VALUE	CODE	Ω VALUE	CODE	Ω VALUE	CODE
100	01	178	25	316	49	562	73
102	02	182	26	324	50	576	74
105	03	187	27	332	51	590	75
107	04	191	28	340	52	604	76
110	05	196	29	348	53	619	77
113	06	200	30	357	54	634	78
115	07	205	31	365	55	649	79
118	08	210	32	374	56	665	80
121	09	215	33	383	57	681	81
124	10	221	34	392	58	698	82
127	11	226	35	402	59	715	83
130	12	232	36	412	60	732	84
133	13	237	37	422	61	750	85
137	14	243	38	432	62	768	86
140	15	249	39	442	63	787	87
143	16	255	40	453	64	806	88
147	17	261	41	464	65	825	89
150	18	267	42	475	66	845	90
154	19	274	43	487	67	866	91
158	20	280	44	499	68	887	92
162	21	287	45	511	69	909	93
165	22	294	46	523	70	931	94
169	23	301	47	536	71	953	95
174	24	309	48	549	72	976	96

(7) 0 Ω Marking:

Normally for 01005、0201 and 0402 size, no marking on the body:



Normally, the making of 0 Ω 0603, 0 Ω 0805, 0 Ω 1206, 0 Ω 1210, 0 Ω 1812, 0 Ω 2010, 0 Ω 2512 resistors as following



5.0 Derating Curve:

Resistors shall have a power rating based on continuous load operation at an ambient temperature from -55 °C to 70°C. For temperature in excess of 70°C, the load shall be derate as shown in figure 1

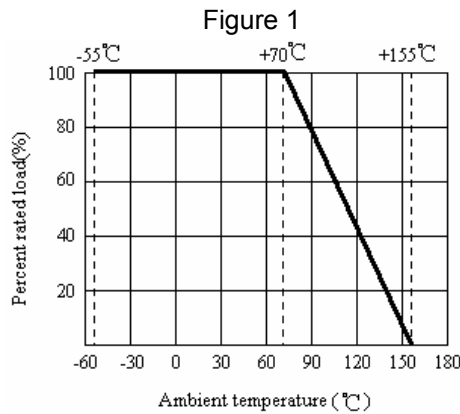

5.1 Voltage rating:

Resistors shall have a rated direct-current (DC) continuous working

voltage or an approximate sine-wave root-mean-square (RMS) alternating-current (AC) continuous working voltage at commercial-line frequency and waveform corresponding to the power rating, as determined from the following formula:

$$RCWV = \sqrt{P \times R}$$

Where: RCWV commercial-line frequency and waveform (Volt.)

P = power rating (WATT.) R = nominal resistance (OHM)

In no case shall the rated DC or RMS AC continuous working voltage be greater than the applicable maximum value.

The overload voltage is 2.5 times RCWV or Max. Overload voltage whichever is less.

6.0 Performance Specification:

Characteristic	Limits	Test Method (JIS-C-5201 & JIS-C-5202)
⊙ Temperature Coefficient	01005: 10Ω ≤ R ≤ 100Ω: ±400PPM/°C >100Ω: ±250PPM/°C	4.8 Natural resistance changes per temp. Degree centigrade $\frac{R_2 - R_1}{R_1(T_2 - T_1)} \times 10^6 \text{ (PPM/°C)}$ R1: Resistance value at room temperature. (T ₁) R2: Resistance value at room temp. plus 100°C (T ₂)
	0201: 1Ω ≤ R ≤ 10Ω: ±400PPM/°C >10Ω: ±200PPM/°C	
	0402~2512: 0.1Ω ≤ R < 1Ω: ±800PPM/°C 1Ω ≤ R ≤ 10Ω: ±400PPM/°C 10Ω < R ≤ 100Ω: ±200PPM/°C 100Ω < R < 10MΩ: ±100PPM/°C 10MΩ ≤ R ≤ 100MΩ: ±200PPM/°C	
	Provided Specially: 0603: 1Ω~10Ω: ±200PPM/°C 0805, 1206: 1Ω~10Ω: ±100PPM/°C	
⊙ *Short-time overload	±0.5%, ±1%	±(1%+0.1Ω)
	±2%, ±5%	±(2%+0.1Ω)
	01005	±(2%+0.1Ω)
	* <50mΩ	
* Dielectric withstanding voltage	No evidence of flashover mechanical damage, arcing or insulation breaks down.	4.7 Resistors shall be clamped in the trough of a 90°C metallic v-block and shall be tested at ac potential respectively specified in the given list of each product type for 1 minute.

◎ *Solderability	95% coverage Min.		4.17 Test temperature of solder: 245°C±3°C dipping time in solder: 2-3 seconds.															
Soldering temp reference	Electrical characteristics shall be satisfied. Without distinct deformation in appearance. (95 % coverage Min.)		<p><u>Wave soldering condition:</u> (2 cycles Max.) Pre-heat: 100~120°C, 30±5 sec. Suggestion solder temp.: 235~255°C, 10sec. (Max.) Peak temp.: 260°C</p> <p><u>Reflow soldering condition:</u> (2 cycles Max.) Pre-heat: 150~180°C, 90~120sec. Suggestion solder temp.: 235~255°C, 20~40sec. Peak temp.: 260°C</p> <p>Temperature profile for avaluation</p> <p><u>Hand soldering condition:</u> The soldering iron tip temperature should be less than 300°C and maximum contract time should be 5 sec.</p>															
◎ Temperature cycling	±0.5%,±1%	±(0.5%+0.05 Ω)	4.19 Resistance change after continuous five cycles for duty cycle specified below:															
	±2%,±5%	±(1.0%+0.05 Ω)																
	01005	±(1%+0.05 Ω)																
				<table border="1"> <thead> <tr> <th>Step</th> <th>Temperature</th> <th>Time</th> </tr> </thead> <tbody> <tr> <td>1</td> <td>-55°C±3°C</td> <td>30 mins</td> </tr> <tr> <td>2</td> <td>Room temp.</td> <td>10 --- 15 mins</td> </tr> <tr> <td>3</td> <td>+155°C±2°C</td> <td>30 mins</td> </tr> <tr> <td>4</td> <td>Room temp.</td> <td>10 --- 15 mins</td> </tr> </tbody> </table>	Step	Temperature	Time	1	-55°C±3°C	30 mins	2	Room temp.	10 --- 15 mins	3	+155°C±2°C	30 mins	4	Room temp.
Step	Temperature	Time																
1	-55°C±3°C	30 mins																
2	Room temp.	10 --- 15 mins																
3	+155°C±2°C	30 mins																
4	Room temp.	10 --- 15 mins																
◎ Soldering heat	Resistance change rate is: ±(1.0%+0.05 Ω)		4.18 Dip the resistor into a solder bath having a temperature of 260°C±5°C and hold it for 10±1 seconds.															
Terminal bending	±(1.0%+0.05 Ω)		4.33 Twist of test board: Y/x = 3/90 mm for 60Seconds															
* Insulation resistance	1,000 MΩ or more		4.6 The measuring voltage shall be ,measured with a direct voltage of (100±15)V or a voltage equal to the dielectric withstanding voltage., and apply for 1min															
◎ Humidity (steady state)	±0.5%,±1%	±(0.5%+0.1Ω)	4.24 Temporary resistance change after 240 hours exposure in a humidity test chamber controlled at 40±2°C and 90-95% relative humidity,															
	±2%,±5%	±(3.0%+0.1Ω)																
	01005	±(3.0%+0.05Ω)																
◎ *Load life in humidity	±0.5%,±1%	±(1.0%+0.1Ω)	7.9 Resistance change after 1,000 hours (1.5 hours "ON", 0.5 hour "OFF") at RCWV in a humidity chamber controlled at 40°C±2°C and 90 to 95% relative humidity.															
	±2%,±5%	±(3.0%+0.1Ω)																
	01005	±(3.0%+0.05Ω)																
	* <50mΩ		Apply to rated current for 0Ω															
◎ *Load life	±0.5%,±1%	±(1.0%+0.1Ω)	4.25.1 Permanent resistance change after 1,000 hours operating at RCWV with duty cycle 1.5 hours "ON", 0.5 hour "OFF" at 70°C±2°C ambient.															
	±2%,±5%	±(3.0%+0.1Ω)																
	01005	±(3.0%+0.05Ω)																
	* <50mΩ		Apply to rated current for 0Ω															
The resistors of 0Ω only can do the characteristic noted of *																		
The resistors of 01005 & 0201 only can do the characteristic noted of ◎																		

7.0 Explanation of Part No. System:

The standard Part No. includes 14 digits with the following explanation:

7.1 1st~4th digits

This is to indicate the Chip Resistor.

Example: 01005, 0201, 0402,0603,0805,1206,1210,2010,1812,2512

7.2 5th~6th digits:

7.2.1 This is to indicate the wattage or power rating. To dieting the size and the numbers,

The following codes are used; and please refer to the following chart for detail:

W=Normal Size; S=Small Size; U= Ultra Small Size; “1” ~ “G” to denotes “1” ~ “16” as Hexadecimal:

1/16W~1W:

Wattage	1/32	3/4W	1/2	1/3	1/4	1/8	1/10	1/16	1/20W	1
Normal Size	WH	07	W2	W3	W4	W8	WA	WG	WM	1W
Small Size	/	07	S2	S3	S4	S8	SA	SG	/	1S

7.2.2 For power rating less or equal to 1 watt, the 5th digit will be the letters W or S to represent the size required & the 6th digit will be a number or a letter code.

Example: WA=1/10W; S4=1/4W-S

7.3 The 7th digit is to denote the Resistance Tolerance. The following letter code is to be used for indicating the standard Resistance Tolerance.

D=±0.5% F=±1% G=±2% J=±5% K= ±10%

7.4 The 8th to 11th digits is to denote the Resistance Value.

7.4.1 For the standard resistance values of 5%&10% series, the 8th digit is “0” ,the 9th & 10th digits are to denote the significant figures of the resistance and the 11th digit is the number of zeros following;

For the standard resistance values of ≤2% series in, the 8th digit to the 10th digits is to denote the significant figures of the resistance and the 11th digit is the zeros following.

7.4.2 The following number s and the letter codes are to be used to indicate the number of zeros in the 11th digit:

0=10⁰ 1=10¹ 2=10² 3=10³ 4=10⁴ 5=10⁵ 6=10⁶ J=10⁻¹ K=10⁻² L=10⁻³ M=10⁻⁴

7.4.3 The 12th, 13th & 14th digits.

The 12th digit is to denote the Packaging Type with the following codes:

C=Bulk in (Chip Product) T=Tape/Reel

7.4.4 The 13th digit is normally to indicate the Packing Quantity of Tape/Reel packaging types. The following letter code is to be used for some packing quantities:

4=4000pcs 5=5000pcs C=10000pcs D=20000pcs E=15000pcs

Chip Product: BD=B/B-20000pcs TC=T/R-10000pcs

7.4.5 For some items, the 14th digit alone can use to denote special features of additional information with the following codes:

E= For “Environmental Protection, Lead Free type” .

S= Provided Specially.

8.0 Ordering Procedure: (Example: 1206 1/4WS ±5% 33Ω T/R-5000)

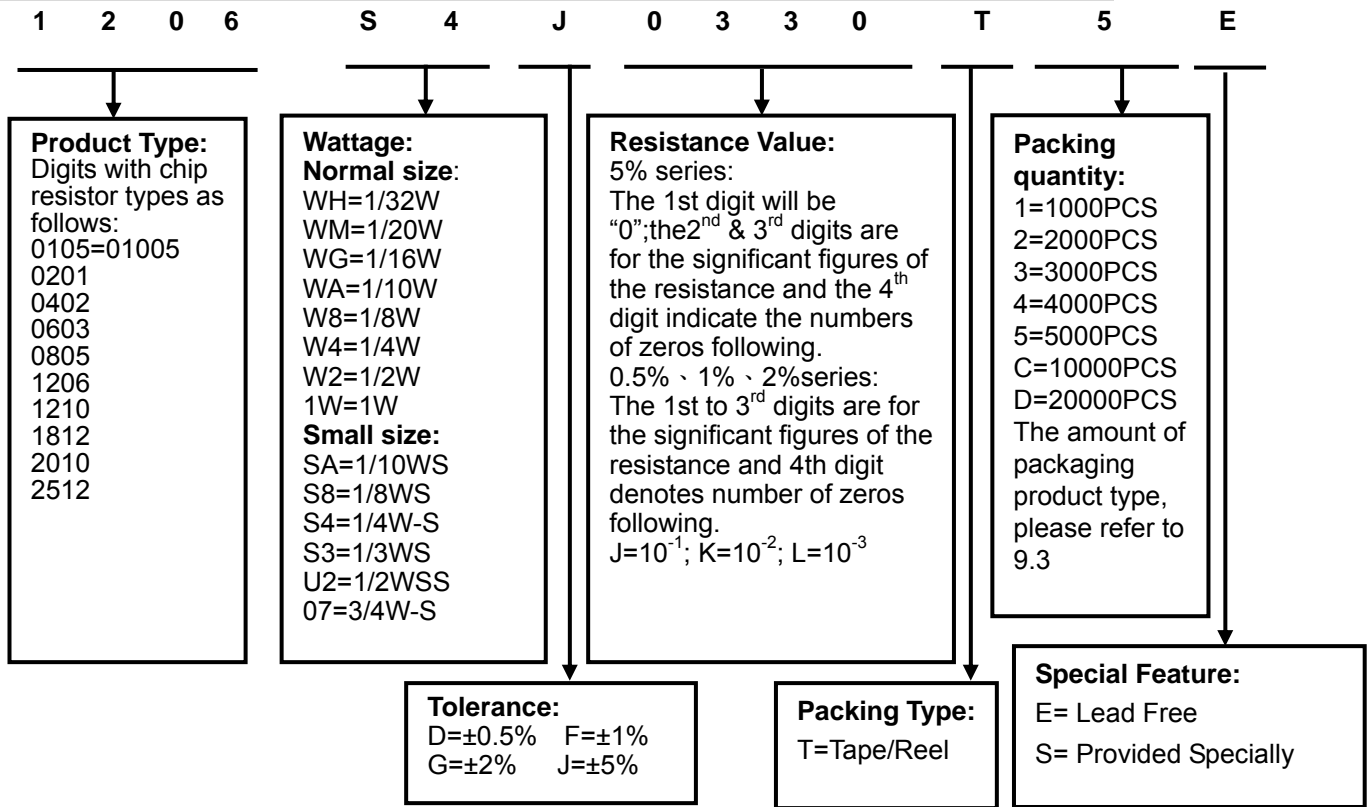

9.0 Packaging:

9.1 Tapping Dimension:

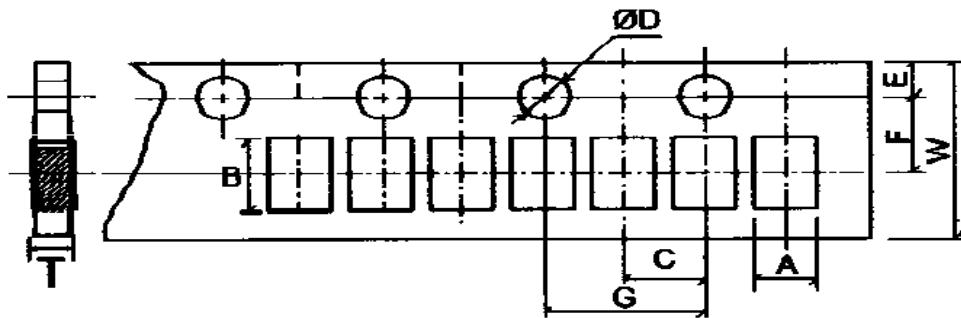

Unit: mm

Type	A	B	C±0.05	+0.1 ΦD -0	E±0.1	F±0.05	G±0.1	W±0.2	T±0.1
01005	0.24±0.05	0.45±0.05	2.00	1.50	1.75	3.50	4.00	8.00	0.40
0201	0.40±0.05	0.70±0.05	2.00	1.50	1.75	3.50	4.00	8.00	0.42
0402	0.65±0.20	1.15±0.20	2.00	1.50	1.75	3.50	4.00	8.00	0.45

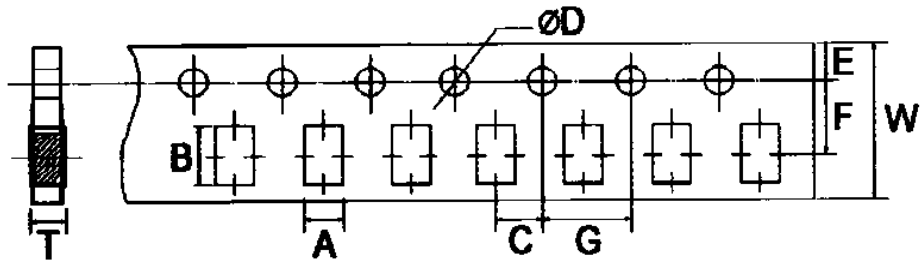

Unit: mm

Type	A ±0.2	B ±0.2	C±0.05	ΦD $\begin{matrix} +0.1 \\ -0 \end{matrix}$	E±0.1	F±0.05	G±0.1	W±0.2	T±0.1
0603	1.10	1.90	2.00	1.50	1.75	3.50	4.00	8.00	0.67
0805	1.65	2.40	2.00	1.50	1.75	3.50	4.00	8.00	0.81
1206	2.00	3.60	2.00	1.50	1.75	3.50	4.00	8.00	0.81
1210	2.80	3.50	2.00	1.50	1.75	3.50	4.00	8.00	0.75

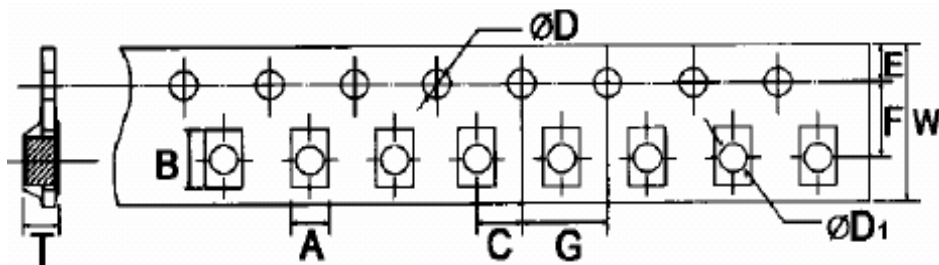

Unit: mm

Type	A±0.2	B±0.2	C±0.05	ΦD $\begin{matrix} +0.1 \\ -0 \end{matrix}$	$\Phi D1$ $\begin{matrix} +0.1 \\ -0 \end{matrix}$	E±0.1	F±0.05	G±0.1	W±0.2	T±0.1
1812	3.50	4.80	2.00	1.50	1.50	1.75	5.50	4.00	12.00	1.00
2010	2.90	5.60	2.00	1.50	1.50	1.75	5.50	4.00	12.00	1.00
2512	3.50	6.70	2.00	1.50	1.50	1.75	5.50	4.00	12.00	1.00

9.2 Peeling Strength of Top Cover Tape:

Test Condition: 0.1 to 0.7 N at a peel-off speed of 300 mm / min.

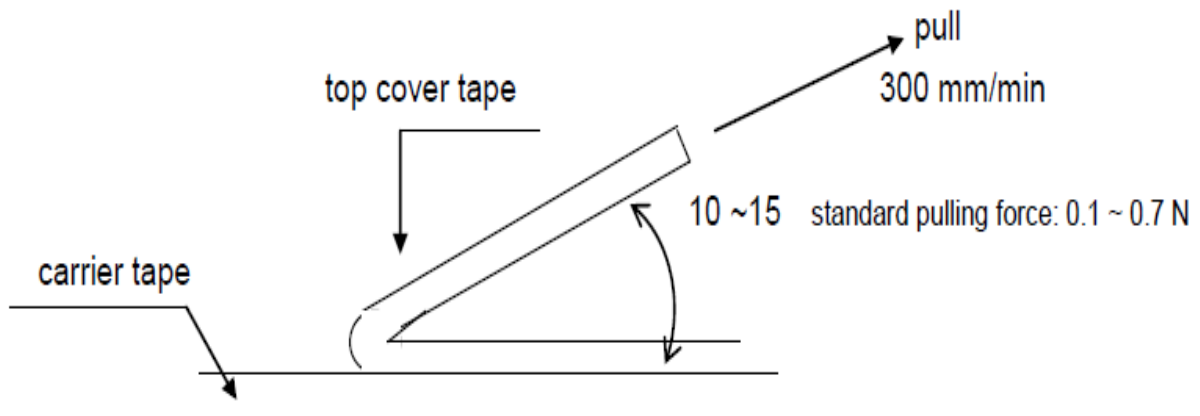

9.3 Dimension:

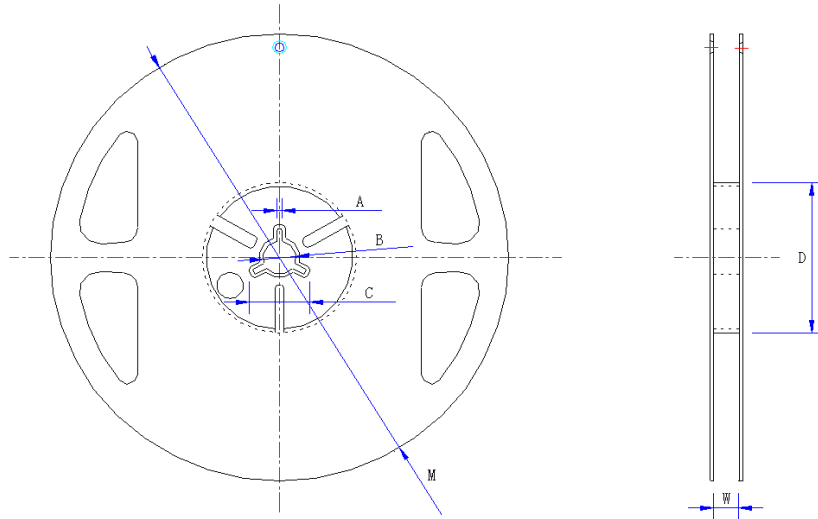

Unit: mm

Type	Taping	Qty/Reel	A±0.5	B±0.5	C±0.5	D±1	M±2	W±1
01005	Paper	20,000pcs	2.0	13.0	21.0	60.0	178.0	10.0
0201	Paper	10,000pcs	2.0	13.0	21.0	60.0	178.0	10.0
0402	Paper	10,000pcs	2.0	13.0	21.0	60.0	178.0	10.0
0603	Paper	5,000pcs	2.0	13.0	21.0	60.0	178.0	10.0
0805	Paper	5,000pcs	2.0	13.0	21.0	60.0	178.0	10.0
1206	Paper	5,000pcs	2.0	13.0	21.0	60.0	178.0	10.0
1210	Paper	5,000pcs	2.0	13.0	21.0	60.0	178.0	10.0
2010	Paper or Embossed	4,000pcs	2.0	13.0	21.0	60.0	178.0	13.8
1812	Embossed	4,000pcs	2.0	13.0	21.0	60.0	178.0	13.8
2512	Embossed	4,000pcs	2.0	13.0	21.0	60.0	178.0	13.8

10.0: Note Matter:

10.1 Environment Related Substance.

This product complies to EU RoHS directive, EU PAHs directive, EU PFOS directive and Halogen free.

10.2 Ozone layer depleting substances.

Ozone depleting substances are not used in our manufacturing process of this product. This product is not manufactured using Chloro fluorocarbons (CFCs), Hydrochlorofluorocarbons (HCFCs), Hydrobromofluorocarbons (HBFCs) or other ozone depleting substances in any phase of the manufacturing process.

10.3 Storage Condition

The performance of these products, including the solderability, is guaranteed for a year from the date of arrival at your company, provided that they remain packed as they were when delivered and stored at a temperature of 5°C~35°C and a relative humidity of 25%~75%RH.

Even within the above guarantee periods, do not store these products in the following conditions. Otherwise, their electrical performance and/or solderability may be deteriorated, and the packaging materials (e.g. taping materials) may be deformed or deteriorated, resulting in mounting failures.

1. In salty air or in air with a high concentration of corrosive gas, such as Cl₂, H₂S, NH₃, SO₂, or NO₂.
2. In direct sunlight.

10.4 The products are used in circuit board thickness greater than 1.6mm. If customers use less than the thickness of the circuit board that you should confirm with the company, in order to recommend a more suitable product.

X-ON Electronics

Largest Supplier of Electrical and Electronic Components

Click to view similar products for [Thick Film Resistors](#) category:

Click to view products by [Uniroyal](#) manufacturer:

Other Similar products are found below :

[MCR03EZPFX3162](#) [MCR004YZPJ332](#) [201007J022KT4E](#) [201007F1653T4E](#) [201007F6652T4E](#) [0603WAF137KT5E](#) [RTT204702FTE](#)
[RTT203000FTE](#) [RTT2056R0FTE](#) [CR2010F470KE04Z](#) [RTT018451FTH](#) [RTT021802DTH](#) [0402WGF510LTCE](#) [0201WMJ0200TEE](#)
[TR0603B26K7P0550Z](#) [0201WMF5102TEE](#) [1210W2J047KT5E](#) [YLR12-2-4F-W](#) [HOT\(0.25x1.3\)-3.2-0R-I](#) [HOT\(0.4x1.5\)-5.2-0R-I](#)
[HoT\(0.45x1.5\)-8.2-0R-I](#) [0201WMF1103TEE](#) [0201WMF7152TEE](#) [1210W2J0124T5E](#) [201007J010LT4E](#) [201007J0360T4E](#) [201007J0430T4E](#)
[0805W8F931KT5E](#) [1206W4F5231T5E](#) [1210W2J0620T5E](#) [201007J0822T4E](#) [0201WMF1005TCE](#) [0201WMF1212TCE](#) [0201WMF1373TCE](#)
[0201WMF1400TCE](#) [0201WMF2000TEE](#) [0201WMF2001TCE](#) [0201WMF226JTCE](#) [0201WMF2672TCE](#) [0201WMF2803TCE](#)
[0201WMF357JTCE](#) [0201WMF3743TCE](#) [0201WMF430JTCE](#) [0201WMF4990TCE](#) [0201WMF5104TCE](#) [0201WMF510JTEE](#)
[0201WMF5110TCE](#) [0201WMF6652TEE](#) [0201WMF6812TCE](#) [0201WMF8200TCE](#)