

厚 聲 電 子 工 業 有 限 公 司

UNIROYAL ELECTRONICS INDUSTRY CO., LTD.



ISO14001



ISO/TS16949



244546



245468



REG.-Nr.A759



CQC04001010658



Specification for Approval

Customer : 深圳市立创电子商务有限公司

Product Name : LEAD-FREE METAL FILM FIXED RESISTORS

Part Name : MFR SERIES $\pm 0.1\%$ ± 0.25 $\pm 0.5\%$ $\pm 1\%$ 、 $\pm 2\%$ 、 $\pm 5\%$

Part No. : MFRO*****0

88 Longteng Road, Economic & Technical Development Zone, Kunshan City, Jiangsu, CHINA 215334

TEL: 86 512 57631411 / 22 / 33

FAX: 86 512 57631431

E-mail: globalsales@uniohm.com localsales@uniohm.com

| Approved | Checked | Prepared | File NO. | Edition | Date | Page |
|--------------|-----------|----------|------------|---------|----------|------|
| William Zhao | Apple Liu | Wu Yiyun | JLC-01-008 | 1 | 2016/5/9 | 1/13 |



ISO14001



ISO/TS16949



244546



245468



REG.-Nr.A759



CQC04001010658

Content

| | |
|---|------|
| Index..... | Page |
| 1.0 Scope..... | 4 |
| 2.0 Ratings and dimension..... | 4 |
| 3.0 Structure..... | 5 |
| 4.0 Mark..... | 5 |
| 5.0 Derating curve..... | 6 |
| 6.0 Voltage rating..... | 6 |
| 7.0 Specification..... | 7 |
| 8.0 Explanation of Part No. System..... | 8 |
| 9.0 Order procedure..... | 9 |
| 10.0 Standard packing..... | 10 |
| 11.0 Note..... | 13 |

| Approved | Checked | Prepared | File NO. | Edition | Date | Page |
|--------------|-----------|----------|------------|---------|----------|------|
| William Zhao | Apple Liu | Wu Yiyun | JLC-01-008 | 1 | 2016/5/9 | 2/13 |

厚 聲 電 子 工 業 有 限 公 司

UNIROYAL ELECTRONICS INDUSTRY CO., LTD.



ISO14001



ISO/TS16949



244546



245468



REG.-Nr.A759



CQC04001010656

| File Name: MFR SERIES | | Date | 2016/5/9 | Edition No. | 1 |
|---------------------------------|-------------|------|-----------------|-------------|------------|
| Amendment Record | | | | Signature | |
| Edition | Description | Page | Date | Amended by | Checked by |
| | | | | | |

| Approved | Checked | Prepared | File NO. | Edition | Date | Page |
|---------------------|------------------|-----------------|-------------------|----------|-----------------|-------------|
| William Zhao | Apple Liu | Wu Yiyun | JLC-01-008 | 1 | 2016/5/9 | 3/13 |



ISO14001

ISO/TS16949

244546

245468

REG.-Nr.A759

CQC04001010656

1.0 Scope

This file is the specification for Lead-Free Metal Film Fixed Resistors manufactured by UNIOHM.

2.0 Ratings and dimensions

For 1/8W, 1/4WS, 0.4WSS



Other

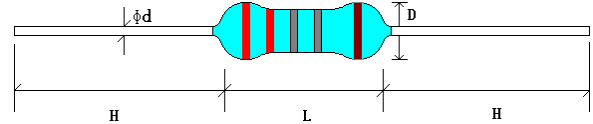

2.1 Normal size

| Type | Dimension(mm) | | | | Max Working Voltage | Max Overload Voltage | Dielectric Withstanding Voltage | Tolerance | Resistance Range |
|---------|---------------|----------|--------|-----|---------------------|----------------------|---------------------------------|-----------|------------------|
| | D | L | d±0.05 | H±3 | | | | | |
| MF 1/8W | 1.9±0.3 | 3.3±0.3 | 0.45 | 28 | 200V | 400V | 400V | ±1%、±2% | 10Ω~1MΩ |
| | | | | | | | | ±5% | 1Ω~1MΩ |
| MF 1/4W | 2.2±0.3 | 6.5±1.0 | 0.54 | 28 | 250V | 500V | 500V | ±1%、±2% | 10Ω~1MΩ |
| | | | | | | | | ±5% | 1Ω~1MΩ |
| MF 1/2W | 3.0±0.6 | 9.5±1.0 | 0.54 | 28 | 350V | 700V | 700V | ±1%、±2% | 10Ω~1MΩ |
| | | | | | | | | ±5% | 1Ω~1MΩ |
| MF 1W | 4.5±0.6 | 11.5±1.0 | 0.65 | 28 | 500V | 1000V | 1000V | ±1%、±2% | 51.1Ω~1MΩ |
| | | | | | | | | ±5% | 1Ω~1MΩ |
| MF 2W | 5.0±0.6 | 15.5±1.0 | 0.70 | 28 | 500V | 1000V | 1000V | ±1%、±2% | 51.1Ω~1MΩ |
| | | | | | | | | ±5% | 1Ω~1MΩ |
| MF 3W | 6.0±0.6 | 17.5±1.0 | 0.75 | 28 | 500V | 1000V | 1000V | ±1%、±2% | 51.1Ω~1MΩ |
| | | | | | | | | ±5% | 1Ω~1MΩ |

2.2 Small Size & ultra Small Size

| Type | Dimension(mm) | | | | Max Working Voltage | Max Overload Voltage | Dielectric Withstanding Voltage | Tolerance | Resistance Range |
|-----------|---------------|----------|--------|-----|---------------------|----------------------|---------------------------------|-------------|------------------|
| | D | L | d±0.05 | H±3 | | | | | |
| MF 1/4WS | 1.9±0.5 | 3.3±0.3 | 0.45 | 28 | 200V | 400V | 200V | ±1%、±2% | 10Ω~1MΩ |
| | | | | | | | | ±5% | 1Ω~1MΩ |
| MF 0.4WSS | 1.9±0.5 | 3.3±0.3 | 0.45 | 28 | 200V | 400V | 200V | ±1%、±2% | 10Ω~1MΩ |
| | | | | | | | | ±5% | 1Ω~1MΩ |
| MF 1/2WSS | 2.2±0.5 | 6.5±0.5 | 0.54 | 28 | 250V | 500V | 250V | ±1% | 10Ω~1MΩ |
| | | | | | | | | ±2%、±5% | 1Ω~1MΩ |
| MF 1/2WS | 2.7±0.5 | 9.0±1.0 | 0.54 | 28 | 350V | 700V | 700V | ±1%、±2% | 10Ω~1MΩ |
| | | | | | | | | ±5% | 1Ω~1MΩ |
| MF 0.6WS | 2.2±0.5 | 6.5±1.0 | 0.54 | 28 | 250V | 500V | 250V | ±1% | 10Ω~1MΩ |
| | | | | | | | | ±2%、±5% | 1Ω~1MΩ |
| MF 1WS | 3.5±0.6 | 9.5±1.0 | 0.60 | 28 | 350V | 700V | 350V | ±1%、±2%、±5% | 10Ω~1MΩ |
| MF 2WS | 4.0±0.6 | 11.5±1.0 | 0.65 | 28 | 500V | 1000V | 350V | ±1%、±2%、±5% | 10Ω~1MΩ |
| MF 3WS | 5.0±0.6 | 15.5±1.0 | 0.70 | 28 | 500V | 1000V | 350V | ±1%、±2%、±5% | 10Ω~1MΩ |

| Approved | Checked | Prepared | File NO. | Edition | Date | Page |
|--------------|-----------|----------|------------|---------|----------|------|
| William Zhao | Apple Liu | Wu Yiyun | JLC-01-008 | 1 | 2016/5/9 | 4/13 |



ISO14001



ISO/TS16949



244546



245468



REG.-Nr.A759



CQC04001610656

3.0 Structure



| No. | Name | Material |
|-----|------------------|---|
| 1 | Basic body | Rod type ceramics |
| 2 | Resistance layer | Metal Film |
| 3 | End cap | Cold steel plated with copper/tin |
| 4 | Lead wire | Tin solder coated copper wire |
| 5 | Joint | By Welding |
| 6 | Coating | 1. Inner paint: Celluloid resin 2. Outer paint: 2.1 Inflammable resin for normal size and 1/2W small size: Blue 2.2 Non-inflammable resin for other small size: Light Green 2.3 Non-inflammable resin for ultra-small size-0.4WSS: Deep Green |
| 7 | Color bands | Epoxy resin |

4.0 Mark

Resistors shall be marked with color bands which in accordance with JIS C 0802

For 1/8W, 1/4WS, 0.4WSS ($\pm 1\%$)

Another

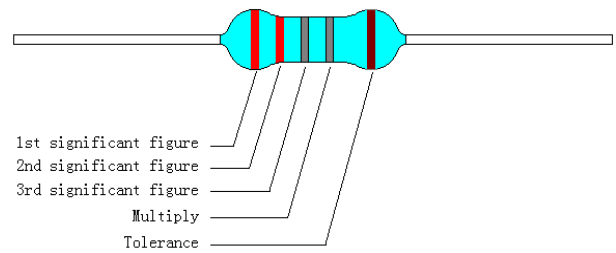
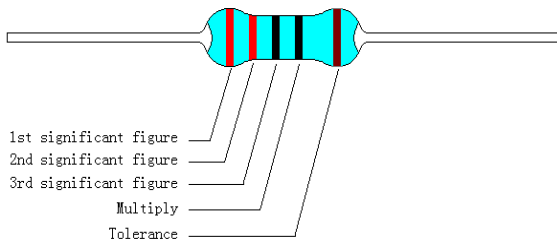

For 1/8W, 1/6W, 1/4WS, 0.4WSS ($\pm 2\%$, $\pm 5\%$)

Another

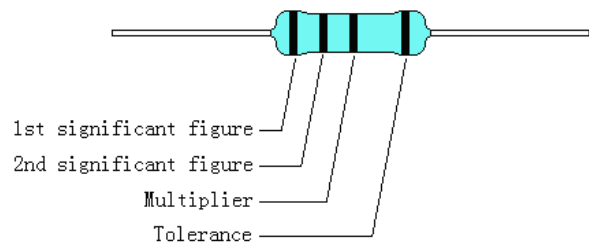
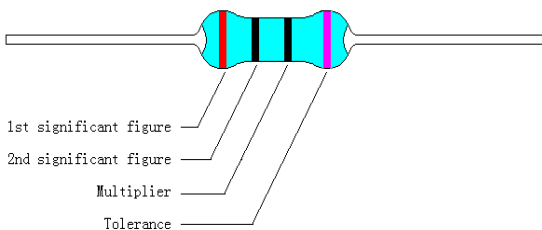

| Approved | Checked | Prepared | File NO. | Edition | Date | Page |
|--------------|-----------|----------|------------|---------|----------|------|
| William Zhao | Apple Liu | Wu Yiyun | JLC-01-008 | 1 | 2016/5/9 | 5/13 |



ISO14001



ISO/TS16949



244546



245468



REG.-Nr.A759



CQC04001010666

4.1 Label: Label includes following items:

- 4.1.1 Type and style
- 4.1.2 Nominal resistance
- 4.1.3 Resistance tolerance
- 4.1.4 Quantity
- 4.1.5 Lot. No.
- 4.1.6 TCR: PPM

Example:

| | |
|----------------------------|------------|
| METAL FILM FIXED RESISTORS | |
| WATT: 2W | VAL: 200KΩ |
| Q'TY: 1,000 | TOL: 1% |
| LOT: 3021548 | PPM: 50 |

5.0 Derating curve:

Resistors shall have a power rating based on continuous load operation at an ambient temperature from -55°C to 70°C. If temperature is above 70°C, the load shall be derate as shown in figure 1

Figure1

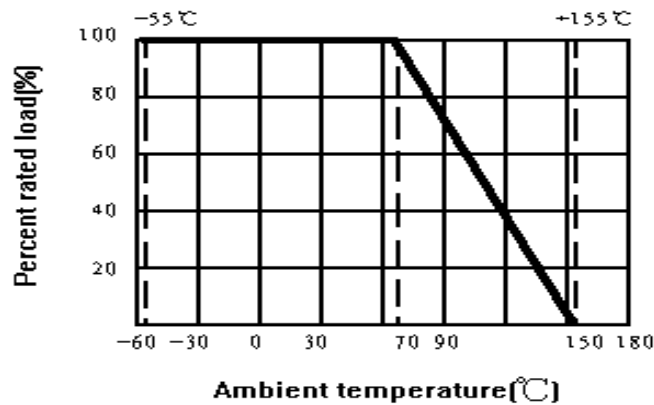

6.0 Voltage rating:

Resistors should have a power rating based on direct-current (DC) continuous voltage rating and an alternating-current (AC) continuous voltage rating which calculating formula shown as below:

$$RCWV = \sqrt{P * R}$$

RCWV: Rated DC or RMS AC continuous working voltage (Volt.)

P: Power Rating (Watt.)

R: Nominal Resistance (Ohm)

Resistors will be burned out if it overload, such as higher than the maximum value of series' RCWV. And we named 2.5 times RCWV is OVERLOAD Voltage.

| Approved | Checked | Prepared | File NO. | Edition | Date | Page |
|--------------|-----------|----------|------------|---------|----------|------|
| William Zhao | Apple Liu | Wu Yiyun | JLC-01-008 | 1 | 2016/5/9 | 6/13 |



ISO14001

ISO/TS16949

244546

245468

REG.-Nr.A759

CQC94001610656

7.0 Specification

| Item | Limits | | Test Method (JIS-C-5201&5202) | | | | | | | | | | | | | | | |
|---------------------------------|---|------------------|---|------|-------------|------|---|-------------|-------|---|------------|------------|---|--------------|-------|---|------------|------------|
| Temperature Coefficient | ± 0.1% | ± 15 PPM/°CMax.. | 4.8 Natural resistance changes per temp. Degree centigrade $\frac{R_2 - R_1}{R_1(T_2 - T_1)} * 10^6 \text{ (PPM/°C)}$ R1: resistance value at room temp. (T1) R2: resistance value at room temp. +100°C (Tt2) Test pattern: room temp. (T1), room temp. +100°C(T2) | | | | | | | | | | | | | | | |
| | ± 0.25% | ± 25 PPM/°CMax.. | | | | | | | | | | | | | | | | |
| | ± 0.5% | ± 50PPM/°CMax.. | | | | | | | | | | | | | | | | |
| | ±1% | ±50PPM/°CMax.. | | | | | | | | | | | | | | | | |
| | ±2% | ±100PPM/°CMax. | | | | | | | | | | | | | | | | |
| | ±5% | ±200PPM/°CMax.. | | | | | | | | | | | | | | | | |
| Short-time overload | Resistance change rate is: ±(0.5%+0.05Ω)Max. With no evidence of mechanical damage. | | 4.13 Permanent resistance change after the application of a potential of 2.5 times RCWV for 5 seconds. | | | | | | | | | | | | | | | |
| Dielectric withstanding voltage | No evidence of flashover mechanical damage, arcing or insulation break down. | | 4.7 Resistors shall be clamped in the trough of a 90°metallic v-block and shall be tested at ac potential respectively specified in the above list for 60-70 seconds. | | | | | | | | | | | | | | | |
| Pulse overload | Resistance change rate is: ± (1%+0.05Ω) Max. With no evidence of mechanical damage. | | 4.28 Resistance change after 10,000 cycles (1 second "ON ", 25 seconds "OFF ") at 4 times RCWV. | | | | | | | | | | | | | | | |
| Resistance to soldering heat | Resistance change rate is: ± (1%+0.05Ω) Max. With no evidence of mechanical damage | | 4.18 Permanent resistance change when leads immersed to a point 2.0-2.5mm from the body in 260°C±5°C solder for 10±1 seconds. | | | | | | | | | | | | | | | |
| Resistance to solvent | No deterioration of protective coatings & markings | | 4.29 Specimens shall be immersed in a bath of trichloroethylene completely for 3 min. With ultrasonic | | | | | | | | | | | | | | | |
| Terminal strength | No evidence of mechanical damage | | 4.16 Direct load: Resistance to a 2.5 kg direct load for 10 seconds in the direction of the longitudinal axis of the terminal leads. Twist test: Terminal leads shall be bent through 90°at a point of about 6mm from the body of the resistor and shall be rotated through 360° about the original axis of the bent terminal in alternating direction for a total of 3 rotations. | | | | | | | | | | | | | | | |
| Solderability | 95% coverage Min. | | 4.17 The area covered with a new, smooth, clean, shiny and continuous surface free from concentrated pinholes. Test temp. Of solder:245°C±3°C Dwell time in solder: 2~3seconds. | | | | | | | | | | | | | | | |
| Temperature cycling | Resistance change rate is: ±(1%+0.05Ω) Max.. With no evidence of mechanical damage. | | 4.19 Resistance change after continuous five cycles for duty cycle specified: <table border="1" style="margin-left: 20px;"> <thead> <tr> <th>Step</th> <th>Temperature</th> <th>Time</th> </tr> </thead> <tbody> <tr> <td>1</td> <td>-55°C ± 3°C</td> <td>30min</td> </tr> <tr> <td>2</td> <td>Room temp.</td> <td>10 - 15min</td> </tr> <tr> <td>3</td> <td>+155°C ± 2°C</td> <td>30min</td> </tr> <tr> <td>4</td> <td>Room temp.</td> <td>10 - 15min</td> </tr> </tbody> </table> | Step | Temperature | Time | 1 | -55°C ± 3°C | 30min | 2 | Room temp. | 10 - 15min | 3 | +155°C ± 2°C | 30min | 4 | Room temp. | 10 - 15min |
| Step | Temperature | Time | | | | | | | | | | | | | | | | |
| 1 | -55°C ± 3°C | 30min | | | | | | | | | | | | | | | | |
| 2 | Room temp. | 10 - 15min | | | | | | | | | | | | | | | | |
| 3 | +155°C ± 2°C | 30min | | | | | | | | | | | | | | | | |
| 4 | Room temp. | 10 - 15min | | | | | | | | | | | | | | | | |
| Load life in humidity | Normal type: ±1.5%; flame retardant type: ±5% | | 7.9 resistance change after 1,000 hours (1.5 hours "ON",0.5 hour "OFF") at RCWV in a humidity test chamber controlled at 40°C±2°C and 90 to 95% relative humidity. | | | | | | | | | | | | | | | |
| Load life | Normal type: ±1.5%; flame retardant type: ±5% | | 4.25.1 permanent resistance change after 1,000 hours operating at RCWV with duty cycle of 1.5 hours "ON", 0.5 hour "OFF" at 70°C±2°C ambient. | | | | | | | | | | | | | | | |

| Approved | Checked | Prepared | File NO. | Edition | Date | Page |
|--------------|-----------|----------|------------|---------|----------|------|
| William Zhao | Apple Liu | Wu Yiyun | JLC-01-008 | 1 | 2016/5/9 | 7/13 |



ISO14001



ISO/TS16949



244546



245468



REG.-Nr.A759



CQC04001610656

8.0 Explanation of Part No. System:

The standard Part No. includes 14 codes which explained as below:

8.1 1st ~ 4th codes: Item type

8.1.1 The 1st to 3rd codes: Product type;

8.1.2 The 4th code: Special feature.

Example: MFRF= Metal Film Fixed Resistors Non-flame type;

8.2 5th~6th codes: Power rating.

8.2.1 W=Normal Size; S=Small Size; U=Ultra Small Size;

1/16W~1/2W (<1W)

| | | | | | | | | |
|------------------|-----|-----|-----|-----|-----|-----|-----|-----|
| Wattage | 1/2 | 1/3 | 1/4 | 1/5 | 1/6 | 1/8 | 0.6 | 0.4 |
| Normal Size | W2 | W3 | W4 | W5 | W6 | W8 | / | / |
| Small Size | S2 | S3 | S4 | S5 | S6 | S8 | 06 | / |
| Ultra-Small Size | U2 | U3 | U4 | U5 | U6 | U8 | / | 04 |

1W~16W (≥1W)

| | | | | | | | | | |
|------------------|----|----|----|----|----|----|----|----|----|
| Wattage | 1 | 2 | 3 | 5 | 7 | 8 | 9 | 10 | 15 |
| Normal Size | 1W | 2W | 3W | 5W | 7W | 8W | 9W | AW | FW |
| Small Size | 1S | 2S | 3S | 5S | 7S | 8S | 9S | AS | FS |
| Ultra-Small Size | 1U | 2U | 3U | 5U | 7U | 8U | 9U | AU | FU |

8.2.2 If power rating is less than 1 watt, 5th code would be the letters W, S or U and 6th code would be a number or a letter code.

Example: WA=1/10W; U2=1/2W-SS.

8.2.3 If power rating is between 1~16 watt, 5th code would be a number or a letter code and 6th code will be the letters of W, S or U.

Example: AW=10W; 3S=3W-S

8.3 7th code: Resistance Tolerance.

B=±0.1% C=±0.25% D=±0.5% F=±1% G=±2% J=±5%

8.4 8th ~ 11th codes: Resistance Value

8.4.1 If resistance value belongs to E-24 series:

8.4.1.1 8th code must be "0"

8.4.1.2 9th & 10th codes: Significant figures of the resistance;

8.4.1.3 11th code: Power of ten.

8.4.2 If resistance value belongs to E-96 series:

8.4.2.1 8th ~10th codes: Significant figures of the resistance

8.4.2.2 11th code: Power of ten.

| | | | | | | |
|--------------|-----------|----------|------------|---------|----------|------|
| Approved | Checked | Prepared | File NO. | Edition | Date | Page |
| William Zhao | Apple Liu | Wu Yiyun | JLC-01-008 | 1 | 2016/5/9 | 8/13 |



8.4.2.3 We use this code in 11th code:

0=10⁰ 1=10¹ 2=10² 3=10³ 4=10⁴ 5=10⁵
 J=10⁻¹ K=10⁻² L=10⁻³ M=10⁻⁴

8.5 12th~14th codes.

8.5.1 12th code: Packaging Type

A=Tape/Box (Ammo pack) B=Bulk/Box T=Tape/Reel P=Tape/Box of PT-26

8.5.2 13th code: Packing Quantity of Tape/Box & Tape/Reel packaging types.

A=500pcs B=2500pcs 1=1000pcs 2=2000pcs

8.5.3 If product is FORMED, 13th~14th codes are forming types

MF=M-type with flattened lead wire F0= F-type
 MK= M-type with kinked lead wire F1= F1-type
 ML= M-type with normal lead wire F2= F2-type
 MC= M type with kinked lead and narrow pitch wire F3= F3-type

8.5.4 14th code: Special features of additional information

P=Panasert type 1=Avisert type 1 2=Avisert type 2
 3=Avisert type 3 A=Cutting type CO 1/4W-A type B= Cutting type CO 1/4W-B typ

9.0 Order procedure (Example: MFR 2W ±1% 200KΩ T/B-1000)



| Approved | Checked | Prepared | File NO. | Edition | Date | Page |
|--------------|-----------|----------|------------|---------|----------|------|
| William Zhao | Apple Liu | Wu Yiyun | JLC-01-008 | 1 | 2016/5/9 | 9/13 |



ISO14001



ISO/TS16949



244546



245468



REG.-Nr.A759



CQC04001010656

10.0 Standard Packing:

10.1 Tapes in Box Packing

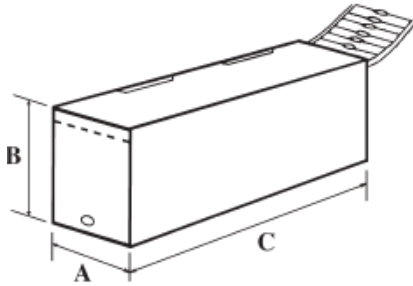

*L1-L2=1.0 Max.
 ZW: 0
 **S=0.5 Max.
 PT-26: 0.8 Max.

Dimension of T/B (mm)

| Part No. | O | P | A±5 | B±5 | C±5 | Qty/Box |
|-----------|------|--------|-----|-----|-----|----------|
| MF 1/8W | 52±1 | 5±0.3 | 75 | 70 | 255 | 5,000pcs |
| MF 1/4WS | 52±1 | 5±0.3 | 75 | 70 | 255 | 5,000pcs |
| MF 1/4W | 52±1 | 5±0.3 | 75 | 98 | 255 | 5,000pcs |
| MF 0.4WSS | 52±1 | 5±0.3 | 75 | 70 | 255 | 5,000pcs |
| MF 1/2WSS | 52±1 | 5±0.3 | 75 | 116 | 255 | 5,000pcs |
| MF 1/2WS | 52±1 | 5±0.3 | 75 | 70 | 255 | 2,000pcs |
| MF 1/2W | 52±1 | 5±0.3 | 75 | 45 | 255 | 1,000pcs |
| MF 0.6WS | 52±1 | 5±0.3 | 75 | 116 | 255 | 5,000pcs |
| MF 1WS | 58±1 | 5±0.3 | 80 | 70 | 255 | 1,000pcs |
| MF 1W | 58±1 | 5±0.3 | 80 | 82 | 255 | 1,000pcs |
| MF 2WS | 58±1 | 5±0.3 | 80 | 82 | 255 | 1,000pcs |
| MF 2W | 65±5 | 10±0.5 | 90 | 88 | 255 | 1000pcs |
| MF 3WS | 65±5 | 10±0.5 | 90 | 119 | 255 | 1000pcs |
| MF 3W | 65±5 | 10±0.5 | 90 | 88 | 255 | 500pcs |

| | | | | | | |
|--------------|-----------|----------|------------|---------|----------|-------|
| Approved | Checked | Prepared | File NO. | Edition | Date | Page |
| William Zhao | Apple Liu | Wu Yiyun | JLC-01-008 | 1 | 2016/5/9 | 10/13 |



ISO14001



ISO/TS16949



244546



245468



REG.-Nr.A759



CQC04001610666

10.2 Tapes in Reel Packing

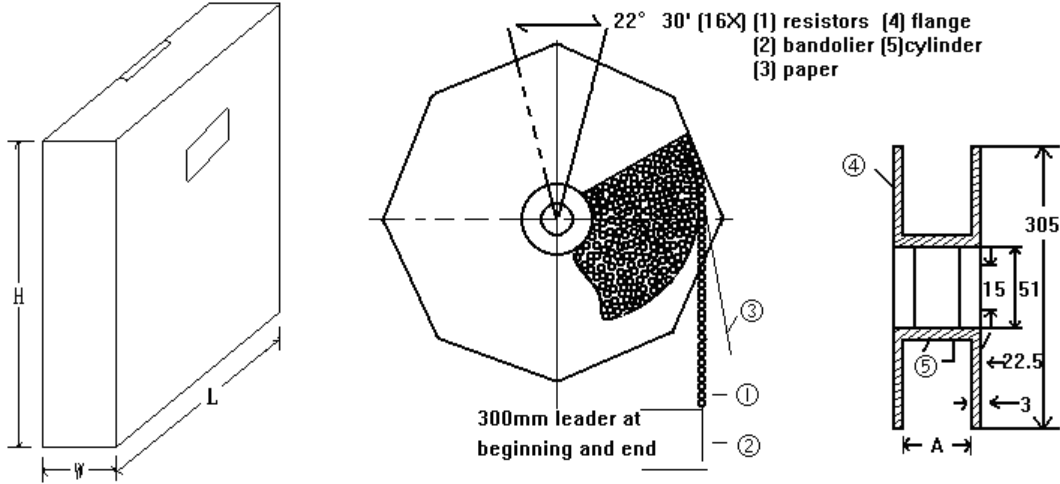

Dimension of Reel (mm)

| Part No. | A | W±5 | H±5 | L±5 | Qty/Box |
|-----------|------|-----|-----|-----|----------|
| MF 1/8W | 73±2 | 85 | 295 | 293 | 5,000pcs |
| MF 1/4WS | 73±2 | 85 | 295 | 293 | 5,000pcs |
| MF 1/4W | 73±2 | 85 | 295 | 293 | 5,000pcs |
| MF 0.4WSS | 73±2 | 85 | 295 | 293 | 5,000pcs |
| MF 1/2WSS | 73±2 | 85 | 295 | 293 | 5,000pcs |
| MF 1/2WS | 73±2 | 85 | 295 | 293 | 4,000pcs |
| MF 1/2W | 73±2 | 85 | 295 | 293 | 4,000pcs |
| MF 0.6WS | 73±2 | 85 | 295 | 293 | 5,000pcs |
| MF 1WS | 73±2 | 85 | 295 | 293 | 2,500pcs |
| MF 1W | 73±2 | 85 | 295 | 293 | 2,500pcs |
| MF 2WS | 73±2 | 85 | 295 | 293 | 2,500pcs |
| MF 2W | 80±5 | 95 | 295 | 293 | 1,000pcs |
| MF 3WS | 80±5 | 95 | 295 | 293 | 1,000pcs |
| MF 3W | 80±5 | 95 | 295 | 293 | 1,000pcs |

| Approved | Checked | Prepared | File NO. | Edition | Date | Page |
|--------------|-----------|----------|------------|---------|----------|-------|
| William Zhao | Apple Liu | Wu Yiyun | JLC-01-008 | 1 | 2016/5/9 | 11/13 |



ISO14001



ISO/TS16949



244546



245468



REG.-Nr.A759



CQC04001010656

10.3 Bulk in Box Packing



Dimension of Box (mm)

| Part No. | A±5 | B±5 | C±5 | Qty/Box |
|-----------|-----|-----|-----|-----------------|
| MF 1/8W | 140 | 80 | 240 | 1,000/20,000pcs |
| MF 1/4WS | 140 | 80 | 240 | 1,000/20,000pcs |
| MF 1/4W | 140 | 80 | 240 | 500/20,000pcs |
| MF 0.4WSS | 140 | 80 | 240 | 1,000/20,000pcs |
| MF 1/2WSS | 140 | 80 | 240 | 500/10,000pcs |
| MF 1/2WS | 140 | 80 | 240 | 500/8,000pcs |
| MF 1/2W | 140 | 80 | 240 | 250/2,000pcs |
| MF 0.6WS | 140 | 80 | 240 | 500/10,000pcs |
| MF 1WS | 140 | 80 | 240 | 200/4,000pcs |
| MF 1W | 140 | 80 | 240 | 100/2,500pcs |
| MF 2WS | 140 | 80 | 240 | 100/2,500pcs |
| MF 2W | 140 | 80 | 240 | 100/1,500pcs |
| MF 3WS | 140 | 80 | 240 | 100/1,500pcs |
| MF 3W | 140 | 80 | 240 | 100/1,500pcs |

| Approved | Checked | Prepared | File NO. | Edition | Date | Page |
|--------------|-----------|----------|------------|---------|----------|-------|
| William Zhao | Apple Liu | Wu Yiyun | JLC-01-008 | 1 | 2016/5/9 | 12/13 |



ISO14001



ISO/TS16949



244546



245468



REG.-Nr.A759



CQC04001010656

11.0 Note

11.1 UNIOHM strongly recommend the storage condition:

Temperature: 15°C~35°C; Humidity :25%~75%.

Even under storage condition UNIOHM recommended, solderability of products over 1 year would be still degraded.

11.2 Store / transport cartons in the correct direction, otherwise bent leads would be occurred due to excessive stress applied when dropping of a carton.

11.3 Product performance and soldered connections may deteriorate if the products are stored in the following places.

11.3.1 In high electrostatic;

11.3.2 In direct sunshine, rain, snow or condensation;

11.3.3 Exposed to sea winds or corrosive gases which contains Cl₂, H₂S, NH₃, SO₂, and NO₂

| Approved | Checked | Prepared | File NO. | Edition | Date | Page |
|--------------|-----------|----------|------------|---------|----------|-------|
| William Zhao | Apple Liu | Wu Yiyun | JLC-01-008 | 1 | 2016/5/9 | 13/13 |

X-ON Electronics

Largest Supplier of Electrical and Electronic Components

Click to view similar products for [Metal Film Resistors - Through Hole](#) category:

Click to view products by [Uniroyal](#) manufacturer:

Other Similar products are found below :

[MF2S-6K8JI](#) [MFP2-20KJI](#) [GP55S-1002-FTW](#) [GP55S-1004-FTW](#) [GP55S-4753-FTW](#) [QW210](#) [RCFH-0.5-5TA](#) [RCFH-100-5TA](#) [RCFH-10-5TA](#) [RCFH-110-5TA](#) [RCFH-11K-5TA](#) [RCFH-11M-5TA](#) [RCFH-12K-5TA](#) [RCFH-130K-5TA](#) [RCFH-13-5TA](#) [RCFH-13K-5TA](#) [RCFH-13M-5TA](#) [RCFH-150K-5TA](#) [RCFH-15-5TA](#) [RCFH-160-5TA](#) [RCFH-160K-5TA](#) [RCFH-16-5TA](#) [RCFH-180K-5TA](#) [RCFH-18K-5TA](#) [RCFH-1M-5TA](#) [RCFH-200-5TA](#) [RCFH-200K-5TA](#) [RCFH-20K-5TA](#) [RCFH-220-5TA](#) [RCFH-220K-5TA](#) [RCFH-22K-5TA](#) [RCFH-2.2M-5TA](#) [RCFH-240K-5TA](#) [RCFH-24K-5TA](#) [RCFH-2-5TA](#) [RCFH-27-5TA](#) [RCFH-27K-5TA](#) [RCFH-2M-5TA](#) [RCFH-330-5TA](#) [RCFH-33-5TA](#) [RCFH-3.3M-5TA](#) [RCFH-360-5TA](#) [RCFH-360K-5TA](#) [RCFH-3.6M-5TA](#) [RCFH-39-5TA](#) [RCFH-39K-5TA](#) [RCFH-3.9M-5TA](#) [RCFH-430-5TA](#) [RCFH-47K-5TA](#) [RCFH-510K-5TA](#)