

### General Description

The U3115S/U3116S Fully operated to +300V is high voltage, high speed power MOSFET and IGBT driver with dependent high and low side referenced output channels.

The logic input is compatible with standard CMOS or LSTTL output, down to 3.3V logic. The output drivers feature a high pulse current buffer stage designed for minimum driver cross-conduction. The floating channel can be used to drive an N-channel power MOSFET or IGBT in the high side configuration which operates up to 300 volts.

#### Packages

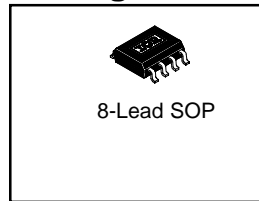

### Key Features

- Floating channel designed for bootstrap operation
- Fully operational to +300V
- Tolerant to negative transient voltage dV/dt immune
- Gate drive supply range from 10 to 20V
- Undervoltage lockout
- 3.3V, 5V and 15V input logic compatible
- Cross-conduction prevention logic
- Matched propagation delay for both channels

### Product Summary

V <sub>OFFSET</sub>	300V max
I <sub>O+/-</sub>	1.2 A / 1.5A
Built-in	DBoot(FR107)
V <sub>CCon/off (typ.)</sub>	10V & 10.3V
t <sub>on/off (typ.)</sub>	600 & 280ns
Deadtime (typ.)	200 ns
Work Tem	- 40 ~ 150°C

### Products Information

Base Part Number	Package Type	Standard OUT		V <sub>OFFSET</sub>	Logic Control
		IO+	IO-		
U3115S	SOP8	1.2A	1.5A	300V	HIN & L $\bar{I}$ N
U3116S	SOP8	1.2A	1.5A	300V	HIN & LIN

### Pin Assignments

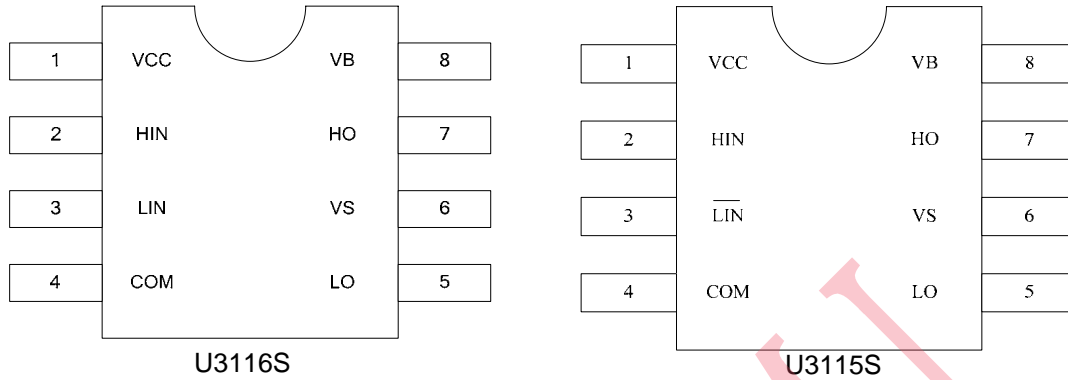

### Pin Function

Number	Symbol	Description
1	VCC	Low side and logic fixed supply
2	HIN	Logic input for high side gate driver outputs (HO), in phase
3	LIN	Logic input for low side gate driver outputs (LO), in phase
	$\overline{\text{LIN}}$	Logic input for low side gate driver outputs (LO), out of phase
4	COM	Low side return
5	LO	Low side gate drive output
6	VS	High side floating supply return
7	HO	High side gate drive output
8	VB	High side floating supply

### Typical Connection

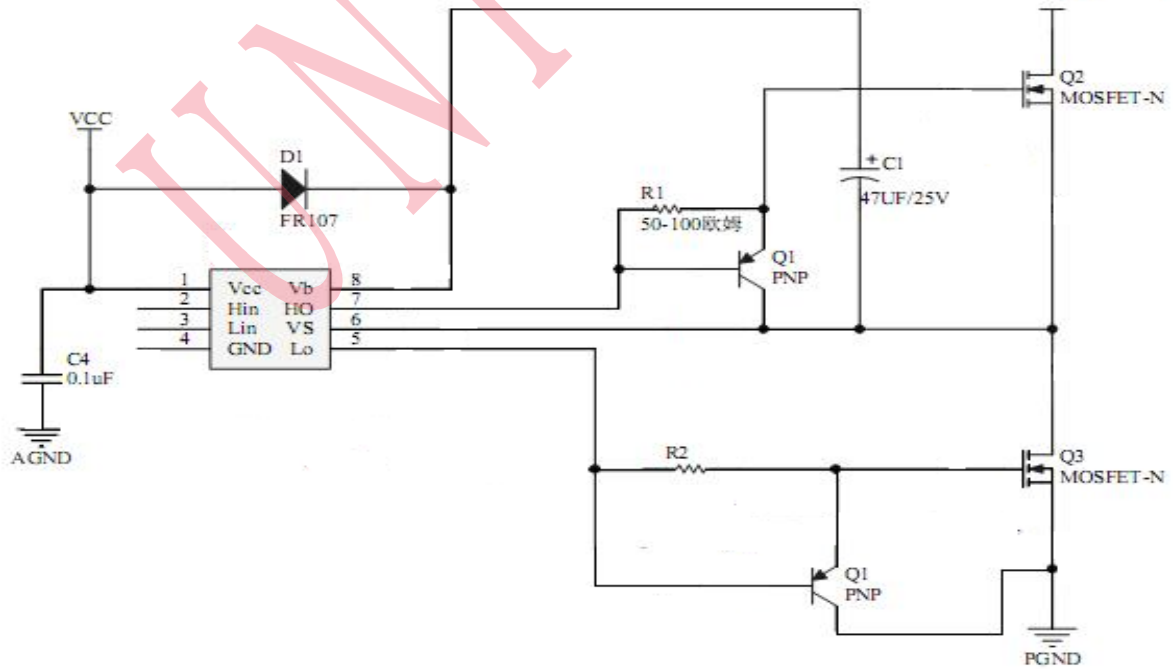
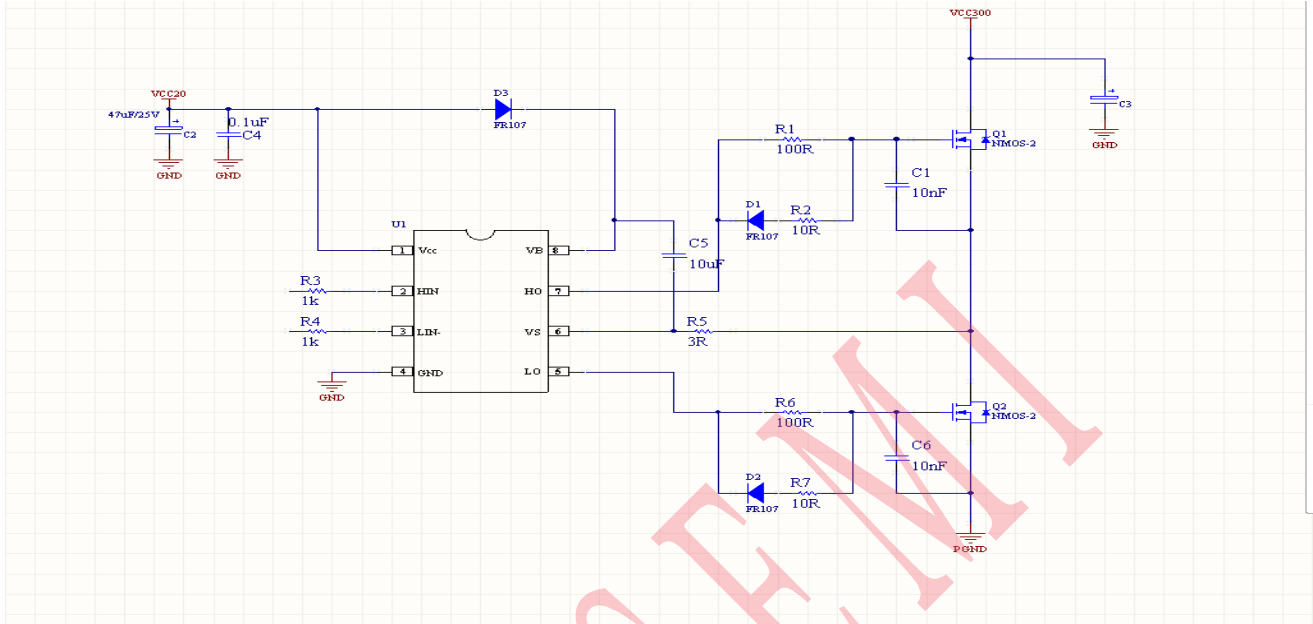

Much Big POWER application

### Absolute Maximum Ratings

Absolute maximum ratings indicate sustained limits beyond which damage to the device may occur. All voltage parameters are absolute voltages referenced to COM. The thermal resistance and power dissipation ratings are measured under board mounted and still air conditions.

Symbol	Definition	Min.	Max.	Units
VB	High side floating absolute voltage	-0.3	300	V
VS	High side floating supply offset voltage	VB-15	VB+0.3	
VHO	High side floating output voltage	VS-0.3	VB+0.3	
VLO	Low side output voltage	-0.3	V <sub>CC</sub> +0.3	
V <sub>CC</sub>	Low side and logic fixed supply voltage	-0.3	35	
VIN	Logic input voltage (HIN & LIN)	-0.3	V <sub>CC</sub> +0.3	
dVS/dt	Allowable offset supply voltage transient	-	55	V/ns
P <sub>D</sub>	Package power dissipation @ TA ≤ +25°C , DIP-8		1	W
	Package power dissipation @ TA ≤ +25°C , SOIC-8		0.625	
R <sub>thJA</sub>	Thermal resistance, junction to ambient , DIP-8		125	°C/W
	Thermal resistance, junction to ambient , SOIC-8		200	
TJ	Junction temperature	-35	150	°C
TS	Storage temperature	-55	175	
TL	Lead temperature (soldering, 10 seconds)		300	

### Recommended Operating Conditions

The Input/Output logic timing diagram is shown in Figure 1. For proper operation the device should be used within the recommended conditions. The VS offset rating is tested with all supplies biased at 15V differential.

Symbol	Definition	Min.	Max.	Units
VB	High side floating supply absolute voltage	VS + 10	VS + 20	V
VS	High side floating supply offset voltage	-10.8	100	
VHO	High side floating output voltage	VS	VB	
VLO	Low side output voltage	0	V <sub>CC</sub>	
V <sub>CC</sub>	Low side and logic fixed supply voltage	10	25	
VIN	Logic input voltage (HIN&LIN)	0	V <sub>CC</sub>	
TA	Ambient temperature	-40	150	°C

### Electrical Characteristic

#### Dynamic Electrical Characteristics

$V_{BIAS} (V_{CC}, V_{BS}) = 15V$ ,  $C_L = 1000 \text{ pF}$  and  $T_A = 25^\circ\text{C}$  unless otherwise specified.

Symbol	Definition	Min.	Typ.	Max.	Units	Test Conditions
$t_{on}$	Turn-on propagation delay	—	600	700	ns	$V_S = 0V$
$t_{off}$	Turn-off propagation delay	—	280	400		$V_S = 90V$
$t_r$	Turn-on rise time	—	600	750		
$t_f$	Turn-off fall time	—	190	300		
DT	Deadtime, LS turn-off to HS turn-on & HS turn-on to LS turn-off	180	200	260		
MT	Delay matching, HS & LS turn-on/off	—	—	60		

### Electrical Characteristic

$V_{CC} = V_{BS} = V_{BIAS} = 15V$   $T_A = 25^\circ\text{C}$  unless otherwise specified.

Symbol	Definition	Min.	Typ.	Max.	Units	Test Conditions
U3115S VCCUV+	VCC supply undervoltage positive going threshold	9.6	10.3	11	V	
U3115S VCCUV-	VCC supply undervoltage negative going threshold	8.6	9.3	10		
U3116S VCCUV+	VCC supply undervoltage positive going threshold	6.1	7.1	8.1		
U3116S VCCUV-	VCC supply undervoltage negative going threshold	5.8	6.8	7.8		
IQCC	Quiescent VCC supply current		300	500	uA	$V_{in} = 0V \text{ or } 5V$
IQBS	Quiescent VBS supply current		100	200		$V_{in} = 0V \text{ or } 5V$
ILK	Offset supply leakage current	-	-	50	uA	$V_B = V_S = 90V$
V <sub>IH</sub>	Logic "1" (HO) & Logic "0" (LO) input voltage	3	-	-		$V_{CC} = 10V \text{ to } 20V$
V <sub>IL</sub>	Logic "0" (HO) & Logic "1" (LO) input voltage	-	-	0.8		$V_{CC} = 10V \text{ to } 20V$
I <sub>IN+</sub>	Logic "1" input bias current	-	3	10		$V_{IN} = 5V$ $= 0V$ $L_{IN}$
I <sub>IN-</sub>	Logic "0" input bias current	-	-	1		$V_{IN} = 5V$ $= 0V$ $L_{IN}$
VOH	High level output voltage, $V_{BIAS} - V_O$	-	-	100		mV
VOL	Low level output voltage, $V_O$	-	-	100	$I_o = 0A$	
IO+	Output high short circuit pulsed current	1000	1200	-	mA	$V_O = 0V, V_{IN} = V_{IH}$ $PW \leq 10 \text{ us}$
IO-	Output low short circuit pulsed current	1200	1500	-		$V_O = 15V, V_{IN} = V_{IL}$ $PW \leq 10 \text{ us}$

### Block Diagram

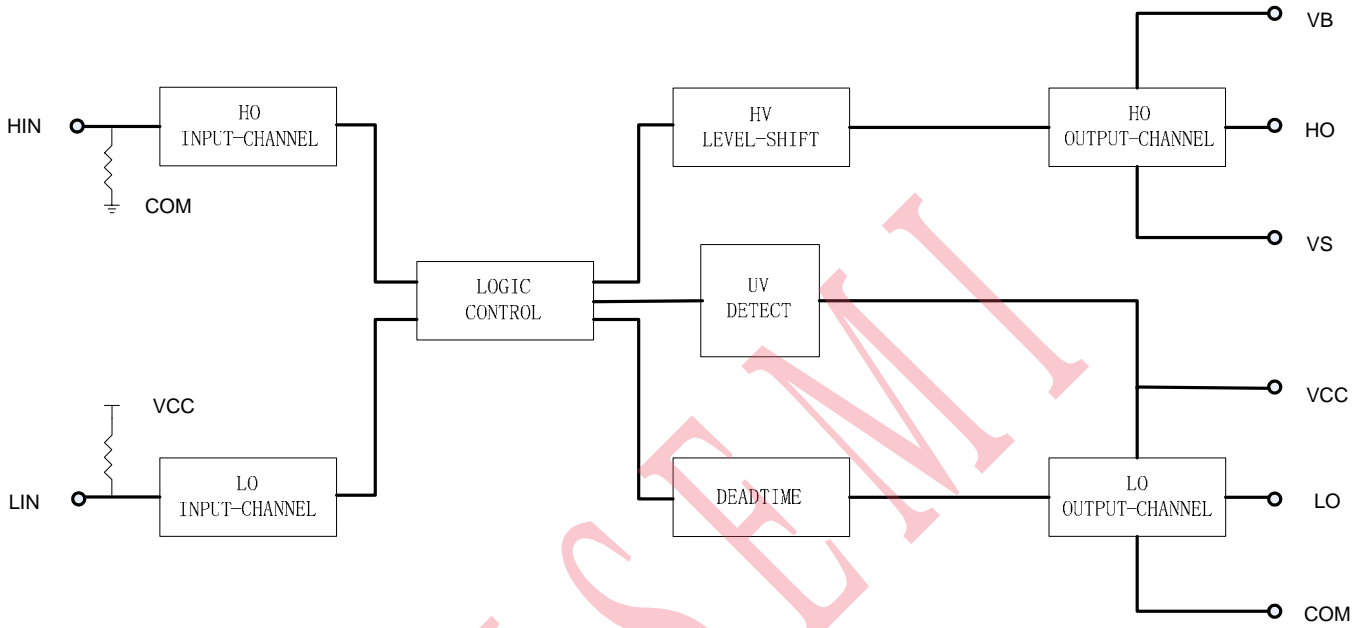

U3116S

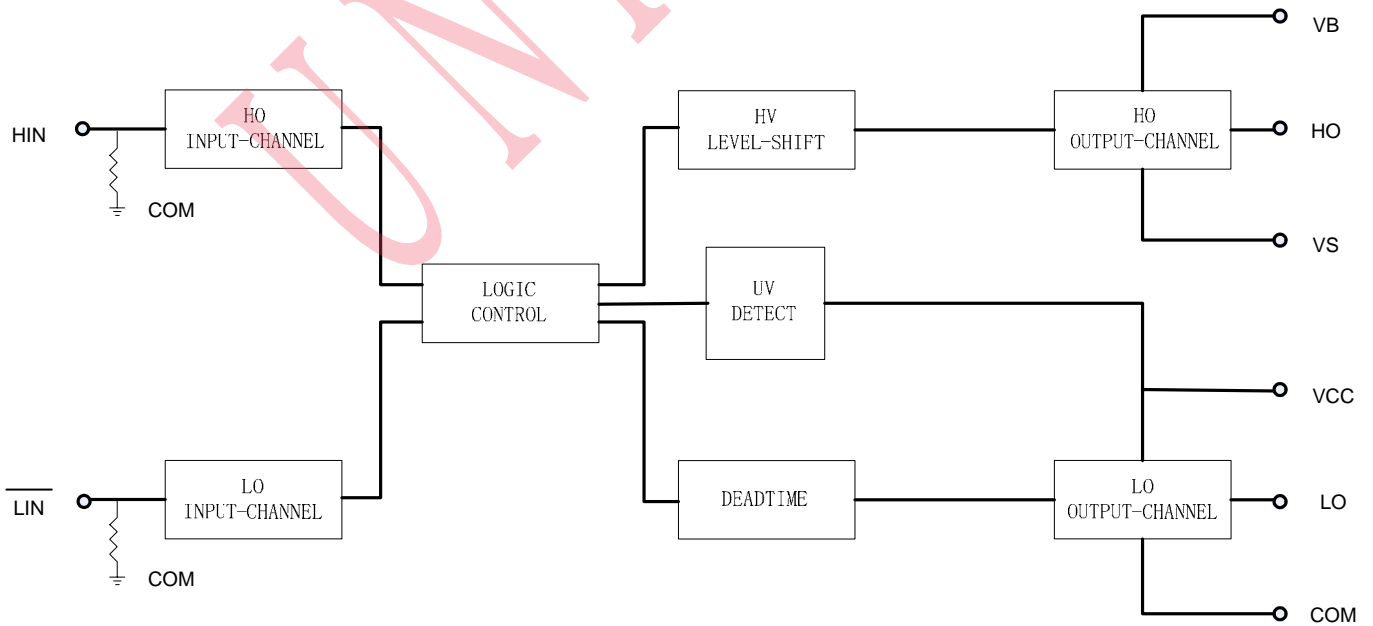

U3115S

### Time waveform

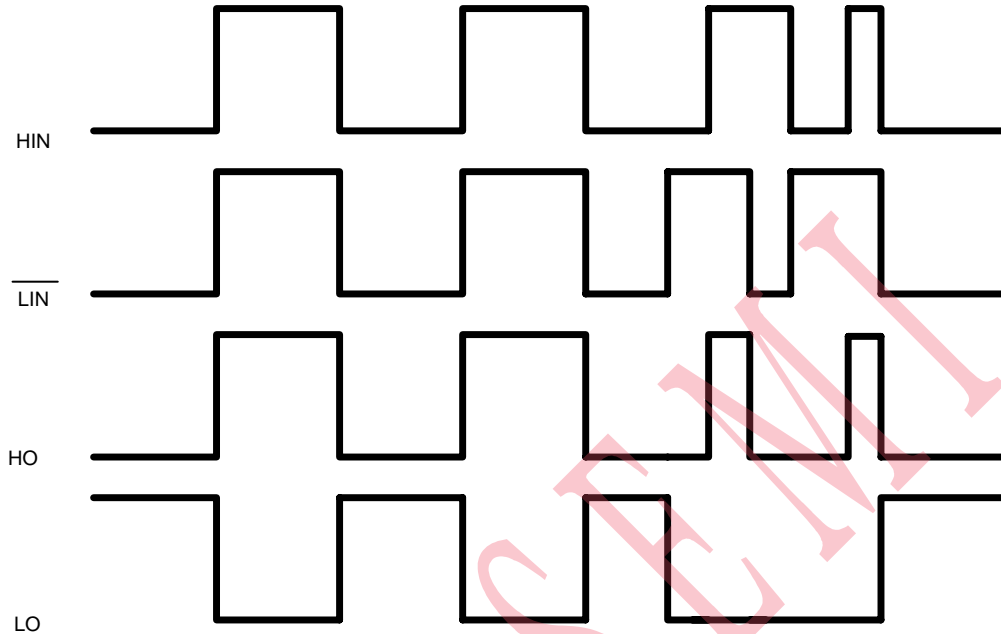

U3115S

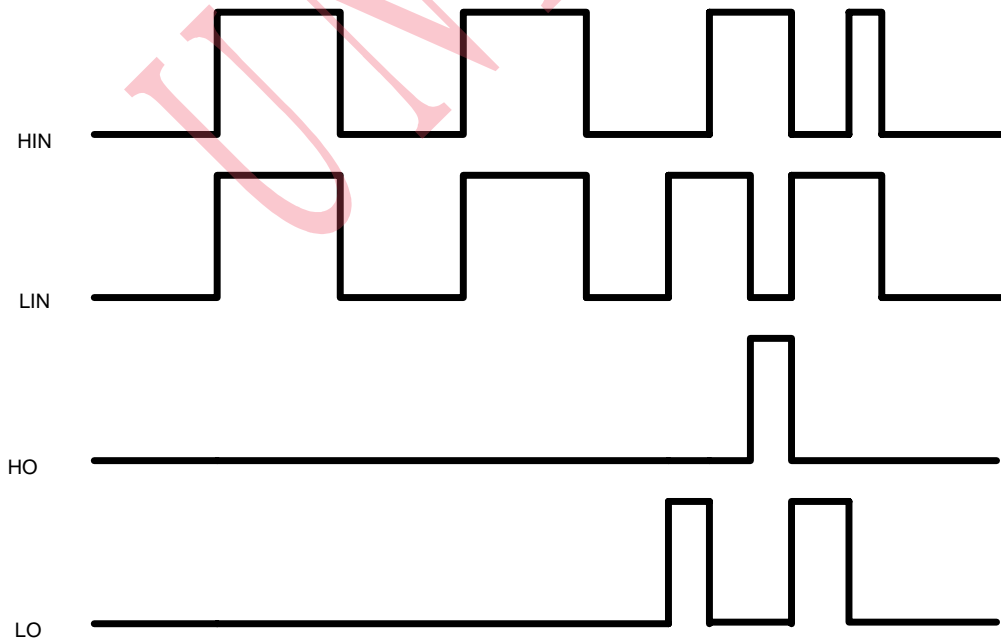

U3116S

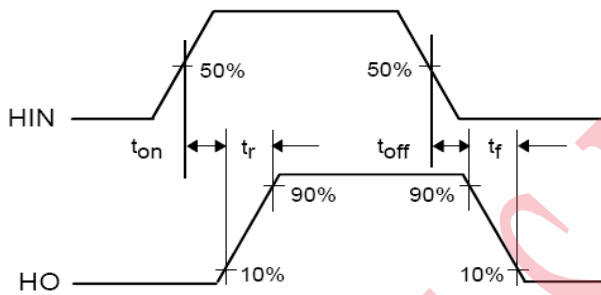
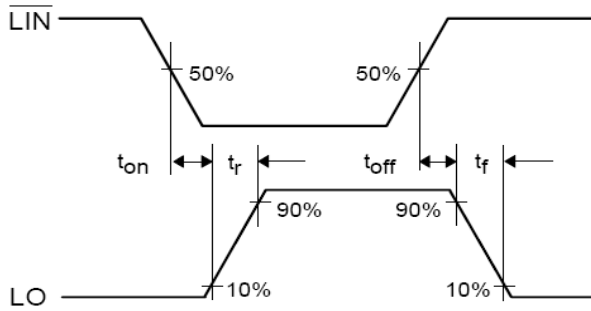

Switching Time Waveform Definitions

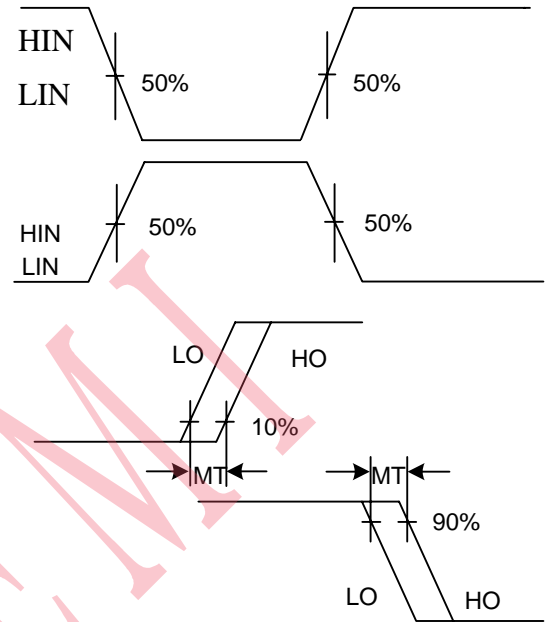

Delay matching time Definitions

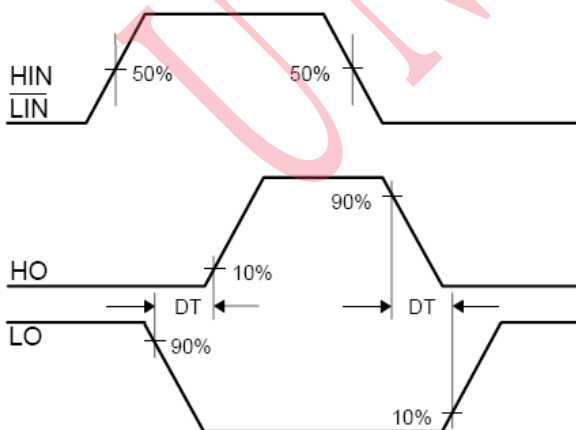

Deadtime Waveform Definitions



### Packaging information SOP8

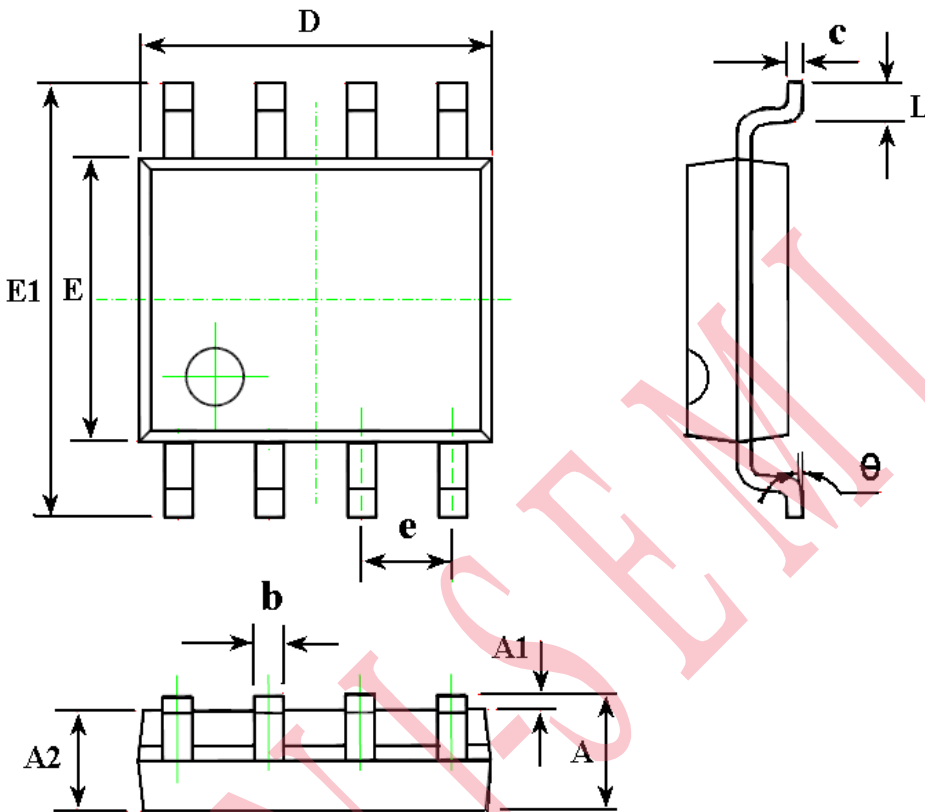

Symbol	Dimensions In Millimeters	
	Min	Max
A	1.350	1.750
A1	0.100	0.250
A2	1.350	1.550
b	0.330	0.510
c	0.170	0.250
D	4.700	5.100
E	3.800	4.000
E1	5.800	6.200
e	1.270 (BSC)	
L	0.400	1.270
θ	0°	8°

## X-ON Electronics

Largest Supplier of Electrical and Electronic Components

*Click to view similar products for [Gate Drivers](#) category:*

*Click to view products by [UNI-SEMI](#) manufacturer:*

Other Similar products are found below :

[00028](#) [00053P0231](#) [8967380000](#) [56956](#) [CR7E-30DB-3.96E\(72\)](#) [57.404.7355.5](#) [LT4936](#) [57.904.0755.0](#) [5801-0903](#) [5803-0901](#) [5811-0902](#)  
[5813-0901](#) [58410](#) [00576P0030](#) [00581P0070](#) [5882900001](#) [00103P0020](#) [00600P0005](#) [00-9050-LRPP](#) [00-9090-RDPP](#) [5951900000](#) [01-](#)  
[1003W-10/32-15](#) [LTI LA6E-1S-WH-RC-FN12VXCR1](#) [0131700000](#) [00-2240](#) [LTP70N06](#) [LVP640](#) [0158-624-00](#) [5J0-1000LG-SIL](#) [020017-13](#)  
[LY1D-2-5S-AC120](#) [LY2-0-US-AC120](#) [LY2-US-AC240](#) [LY3-UA-DC24](#) [00-5150](#) [00576P0020](#) [00600P0010](#) [LZNQ2M-US-DC5](#) [LZNQ2-](#)  
[US-DC12](#) [LZP40N10](#) [00-8196-RDPP](#) [00-8274-RDPP](#) [00-8275-RDNP](#) [00-8609-RDPP](#) [00-8722-RDPP](#) [00-8728-WHPP](#) [00-8869-RDPP](#) [00-](#)  
[9051-RDPP](#) [00-9091-LRPP](#) [00-9291-RDPP](#)