

General Description

The U3315/6 are high voltage, high speed power MOSFET and IGBT drivers with three independent high and low side referenced output channels for 3- phase applications. Proprietary HVIC technology enables ruggedized monolithic construction. Logic inputs are compatible with CMOS or LSTTL outputs, down to 3.3V logic. Propagation delays are matched to simplify use in high frequency applications. The floating channels can be used to drive N-channel power MOSFETs or IGBTs in the high side configuration which operates up to 300 V.

Key Features

- Floating channel designed for bootstrap operation Fully operational to +300 V
- Tolerant to negative transient voltage
- Gate drive supply range from 10 V to 20 V
- Independent 3 half-bridge drivers
- Low side output out of phase with inputs. High side outputs out of phase
- 3.3 V logic compatible
- Lower di/dt gate drive for better noise immunity

Product Summary

V _{OFFSET}	300V max
I _{O+/-}	1.2A / 1.5A
V _{OUT}	8V-25V
V _{CC} on/off (typ.)	8.2 V & 10.3V
t _{on/off} (typ.)	600 & 280ns
Work Tem	-40 ~ 150°C

Products Information

Base Part Number	Package Type	Standard OUT		V _{OFFSET}	Logic Control
		IO+	IO-		
U3315	TSSOP20	1.2A	1.5A	300V	HIN & LIN
U3316	TSSOP20	1.2A	1.5A	300V	HIN & LIN

Typical Application

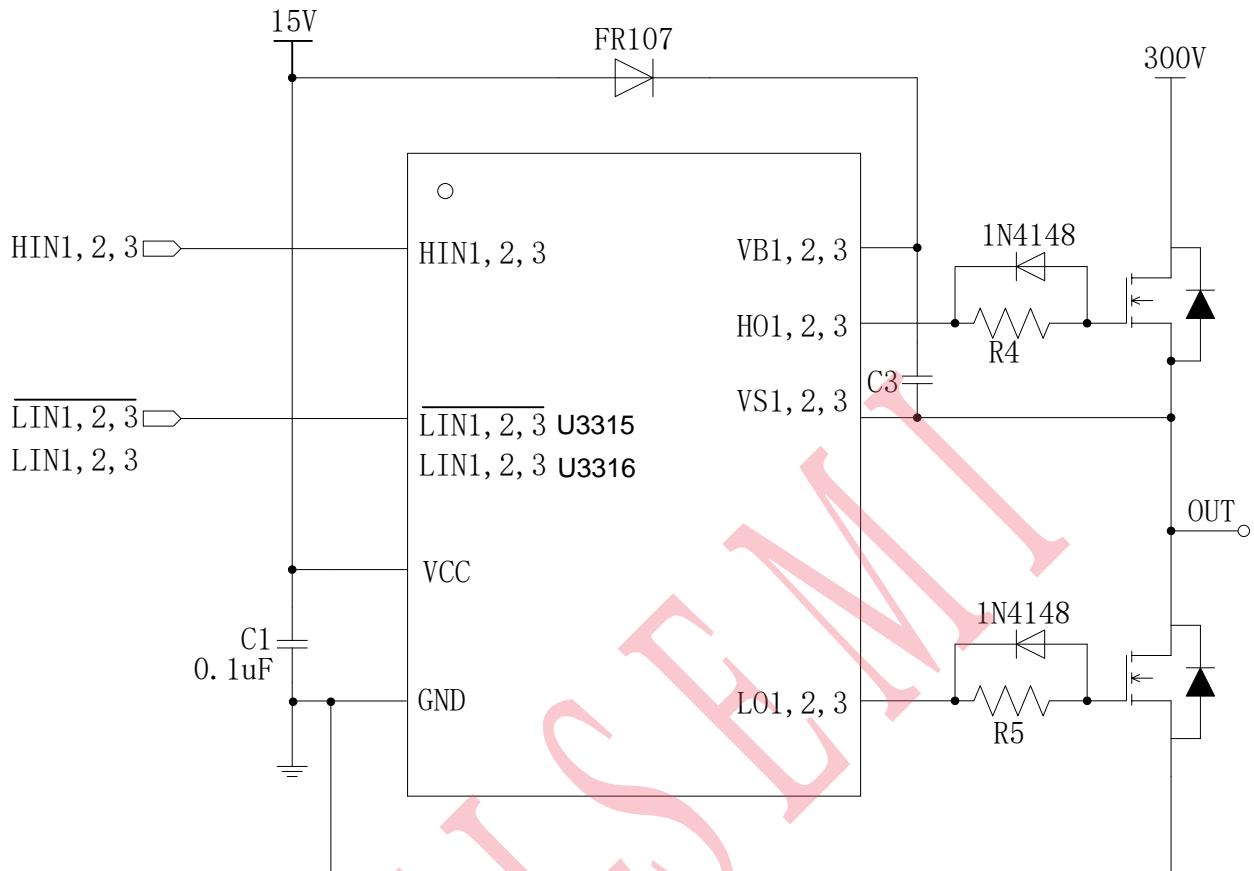

Packages

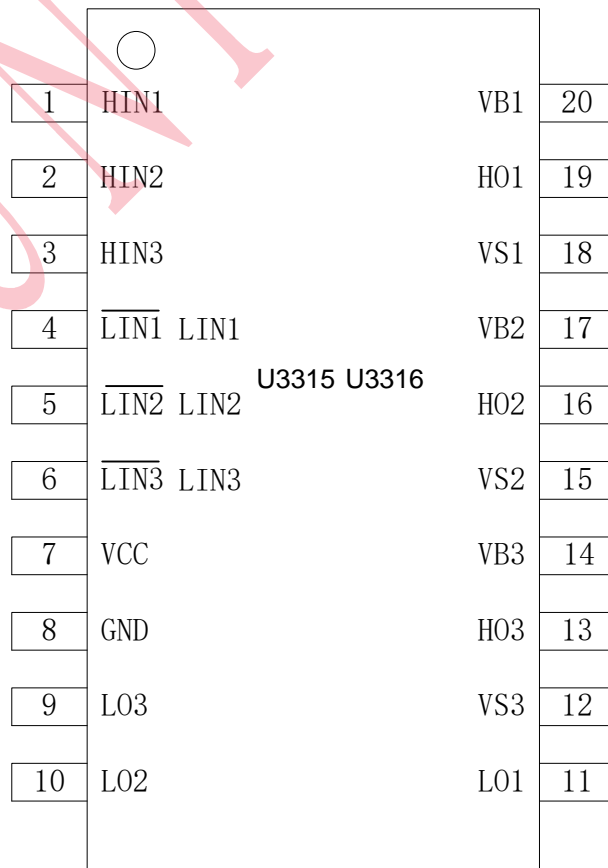

Pin Function

Symbol	Description
VCC	Low side and logic fixed supply
HIN1,2,3	Logic inputs for high side gate driver outputs(HO1,2,3),out of phase
U3316 LIN1,2,3	Logic inputs for high side gate driver outputs(LO1,2,3),out of phase
U3315 LIN1,2,3	Logic inputs for high side gate driver outputs(LO1,2,3),out of phase
GND	Logic Ground
VB1,2,3	High side floating supply
HO1,2,3	High side gate driver outputs
VS1,2,3	High voltage floating supply returns
LO1,2,3	Low side gate driver output

Block Diagram

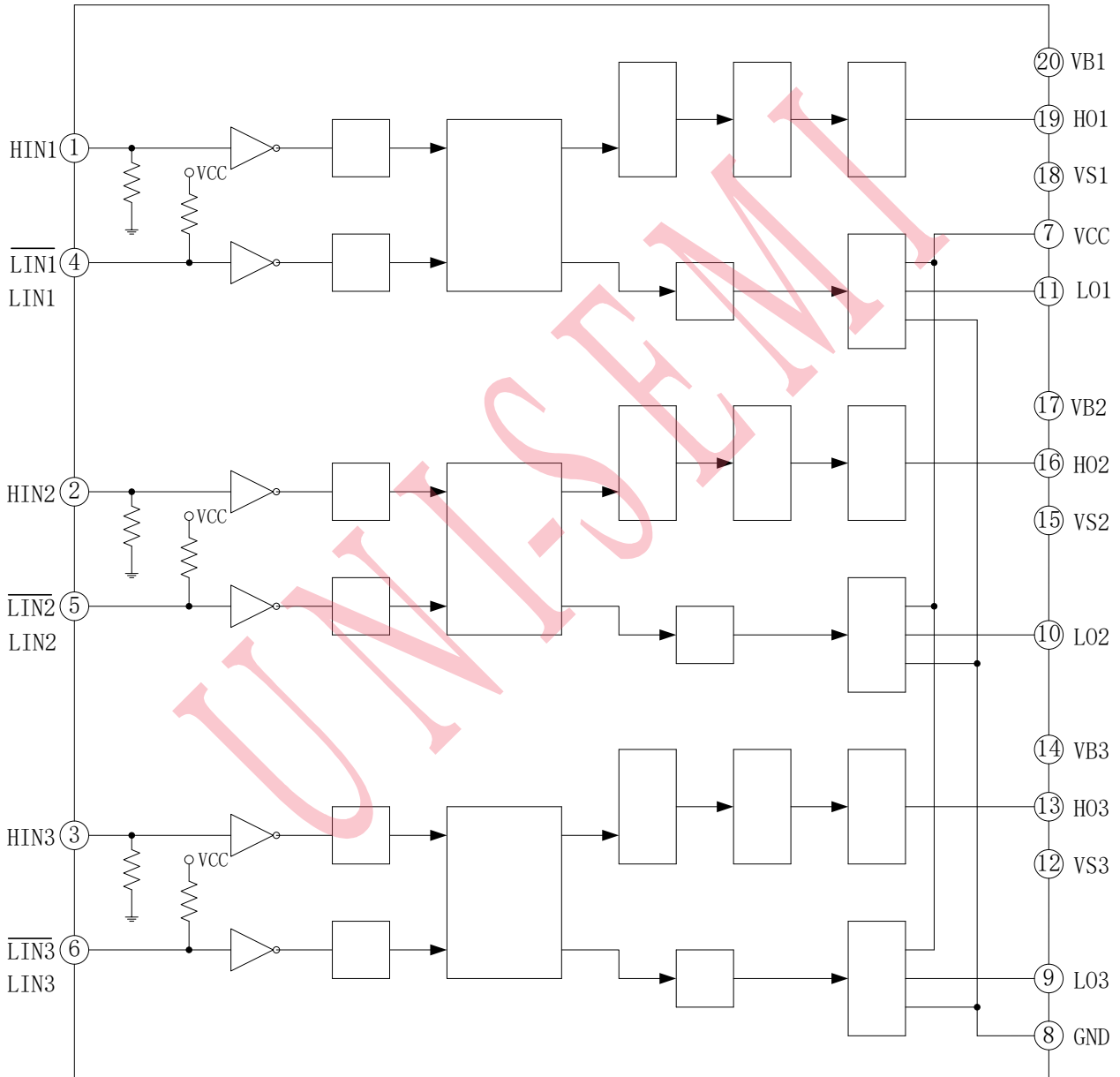

Absolute Maximum Ratings

Absolute maximum ratings indicate sustained limits beyond which damage to the device may occur. All voltage parameters are absolute voltages referenced to GND. The thermal resistance and power dissipation ratings are measured under board mounted and still air conditions.

Symbol	Definition	Min	Max	Units
VS	High side offset voltage	VB 1,2,3 - 25	VB 1,2,3 + 0.3	V
VB	High side floating supply voltage	-0.3	300	
VHO	High side floating output voltage	VS1,2,3 - 0.3	VB 1,2,3 + 0.3	
VCC	Low side and logic fixed supply voltage	-0.3	25	
GND	Logic ground	VCC- 25	VCC+ 0.3	
VLO1,2,3	Low side output voltage	-0.3	VCC+ 0.3	
VIN	Input voltage	GND-0.3	Lower of (GND+ 15) or VCC+ 0.3)	
dV/dt	Allowable offset voltage slew rate	—	50	V/ns
PD	Package power dissipation @ TA ≤+25 °C	—	1.5	W
		—	1.6	
RthJA	Thermal resistance, junction to ambient	—	83	°C/W
		—	78	
TJ	Junction temperature	—	150	°C
TS	Storage temperature	-55	150	
TL	Lead temperature (soldering, 10 seconds)	—	300	

Recommended Operating Conditions

The Input/Output logic timing diagram is shown in figure . For proper operation the device should be used within the recommended conditions. All voltage parameters are absolute referenced to GND. The VS offset rating is tested with all supplies biased at 15V differential

Symbol	Definition	Min	Max	Units
VB1,2,3	High side floating supply voltage	VS1,2,3 +10	VS1,2,3 + 20	V
VS1,2,3	High side floating supply offset voltage	Note 1	200	
VHO 1,2,3	High side output voltage	VS1,2,3	VB1,2,3	
VLO1,2,3	Low side output voltage	0	VCC	
VCC	Low side and logic fixed supply voltage	10	20	
VIN	Logic input voltage	GND	GND + 5	
TA	Ambient temperature	-40	125	°C

Note 1: Logic operational for VS of GND

Electrical Characteristic

Static Electrical Characteristics

Symbol	Definition	Min	Typ	Max	Units	Test Conditions
VCCUV- VBSUV-	VCC and VBS supply undervoltage negative going threshold	7.4	8.2	9.0	V	
VCCUVH VBSUVH	VCC and VBS supply undervoltage lockout hysteresis	0.3	0.7	—		
ILK	Offset supply leakage current	—	—	50	μA	VB1,2,3 = VS1,2,3 = 300 V
IQBS	Quiescent VBS supply current	—	70	120		
IQCC	Quiescent VCC supply current	—	1.6	2.3	mA	VIN = 0 V or 5 V
ILIN+	Input bias current (LOUT = LO)	—	200	300	μA	VLIN = 4.9 V
ILIN-	Input bias current (LOUT = HI)	—	100	220		VLIN = 0 V
IHIN+	Input bias current (HOUT = LO)	—	200	300		VHIN = 4.9 V
IHIN-	Input bias current (HOUT = HI)	—	100	220		VHIN = 0 V
IO+	Output high short circuit pulsed current	—	1200	—	mA	Vo = 0 V, PW ≤ 10 μs
IO-	Output low short circuit pulsed current	—	1500	—		Vo = 15 V, PW ≤ 10 μs

Typical Performance Characteristics

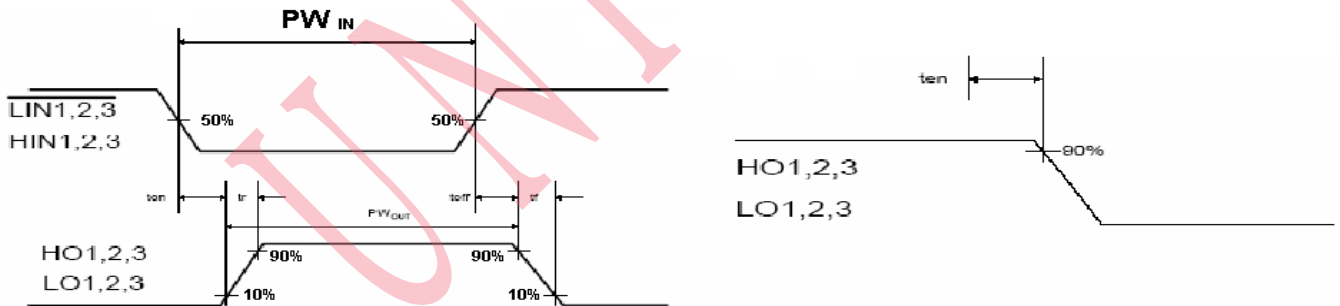
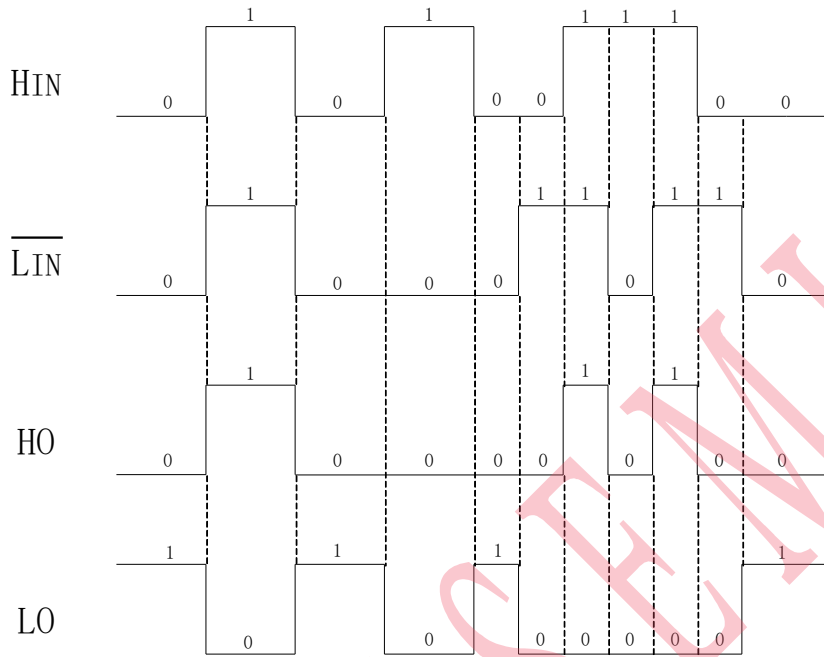

Mechanical Dimensions TSSOP20

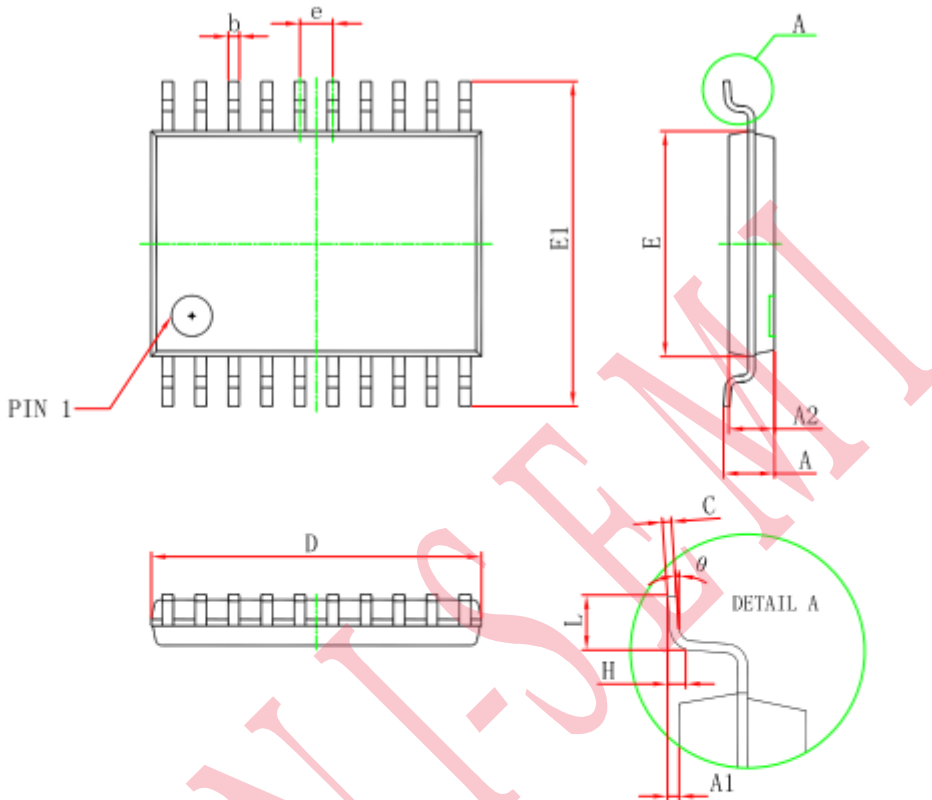

Symbol	Dimensions In Millimeters		Dimensions In Inches	
	Min	Max	Min	Max
D	6.400	6.600	0.252	0.259
E	4.300	4.500	0.169	0.177
b	0.190	0.300	0.007	0.012
e	0.090	0.200	0.004	0.008
E1	6.250	6.550	0.246	0.258
A		1.200		0.047
A2	0.800	1.000	0.031	0.039
A1	0.050	0.150	0.002	0.006
e	0.65 (BSC)		0.026 (BSC)	
L	0.500	0.700	0.020	0.028
H	0.25(TYP)		0.01(TYP)	
θ	1°	7°	1°	7°

Ordering Information

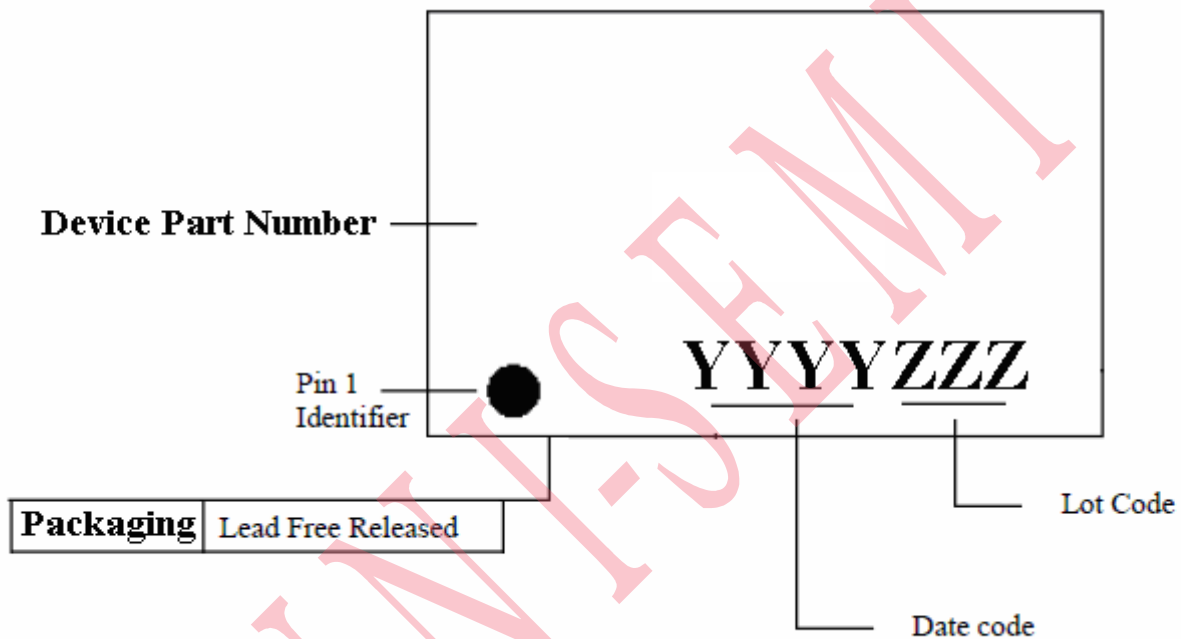

X-ON Electronics

Largest Supplier of Electrical and Electronic Components

Click to view similar products for [Gate Drivers](#) category:

Click to view products by [UNI-SEMI](#) manufacturer:

Other Similar products are found below :

[00028](#) [00053P0231](#) [8967380000](#) [56956](#) [CR7E-30DB-3.96E\(72\)](#) [57.404.7355.5](#) [LT4936](#) [57.904.0755.0](#) [5801-0903](#) [5803-0901](#) [5811-0902](#)
[5813-0901](#) [58410](#) [00576P0030](#) [00581P0070](#) [5882900001](#) [00103P0020](#) [00600P0005](#) [00-9050-LRPP](#) [00-9090-RDPP](#) [5951900000](#) [01-](#)
[1003W-10/32-15](#) [LTI LA6E-1S-WH-RC-FN12VXCR1](#) [0131700000](#) [00-2240](#) [LTP70N06](#) [LVP640](#) [0158-624-00](#) [5J0-1000LG-SIL](#) [020017-13](#)
[LY1D-2-5S-AC120](#) [LY2-0-US-AC120](#) [LY2-US-AC240](#) [LY3-UA-DC24](#) [00-5150](#) [00576P0020](#) [00600P0010](#) [LZNQ2M-US-DC5](#) [LZNQ2-](#)
[US-DC12](#) [LZP40N10](#) [00-8196-RDPP](#) [00-8274-RDPP](#) [00-8275-RDNP](#) [00-8609-RDPP](#) [00-8722-RDPP](#) [00-8728-WHPP](#) [00-8869-RDPP](#) [00-](#)
[9051-RDPP](#) [00-9091-LRPP](#) [00-9291-RDPP](#)