

■ Description

U6620S combines a dedicated current mode PWM mode controller with a 1R/650V MOSFET. U6620S has high efficiency, low standby power consumption, low EMC and low cost. It is applied to the off-line fly back converter in the range of 20W output power. U6620S offers comprehensive protection functions, including Cycle-by-Cycle current limitation (OCP), over temperature protection (OTP), Over voltage clamp (OVP) and under voltage lockout (UVLO) on VCC. U6620S is offered in SOP8 package.

■ Applications

- Cell Phone Charger
- Digital Cameras Charger
- Battery charger

■ Features

- Digit frequency shuffling technology to improve EMI performance.
- Fixed 65kHz PWM switching frequency.
- Leading-edge blanking on current sense.
- Internal synchronized slope compensation.
- Low standby power consumption (<75mW@230Vac)
- Soft-start to reduce MOSFET Vds stress during power on
- Comprehensive protection function
 - Under voltage locked with hysteresis (UVLO) on VCC.
 - Over voltage protection (OVP) on VCC.
 - Cycle-by-Cycle current limitation.
 - Over load protection (OLP)
 - Over temperature protection (OTP)
 - Current limitation compensation to obtain the same output current in universal ac line input
- Low start-up current (<10uA@VCC=12V)

■ Package Information

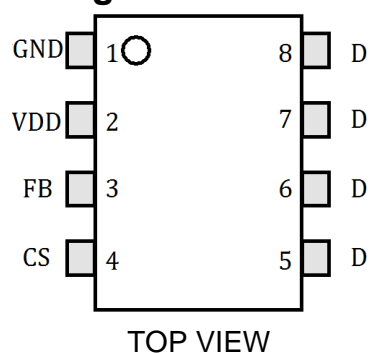

Pin Configuration

Pin Number	Pin Name	Function
1	GND	The ground of the IC.
2	VDD	IC power supply pin.
3	FB	Feedback pin. The loop regulation is achieved by connecting a photocoupler to this pin. PWM duty cycle is determined by this pin voltage and the current sense signal at Pin 4.
4	CS	Current Sense Input Pin.
5、6、7、8	D	The Power MOSFET Drain.

Typical Application Circuit

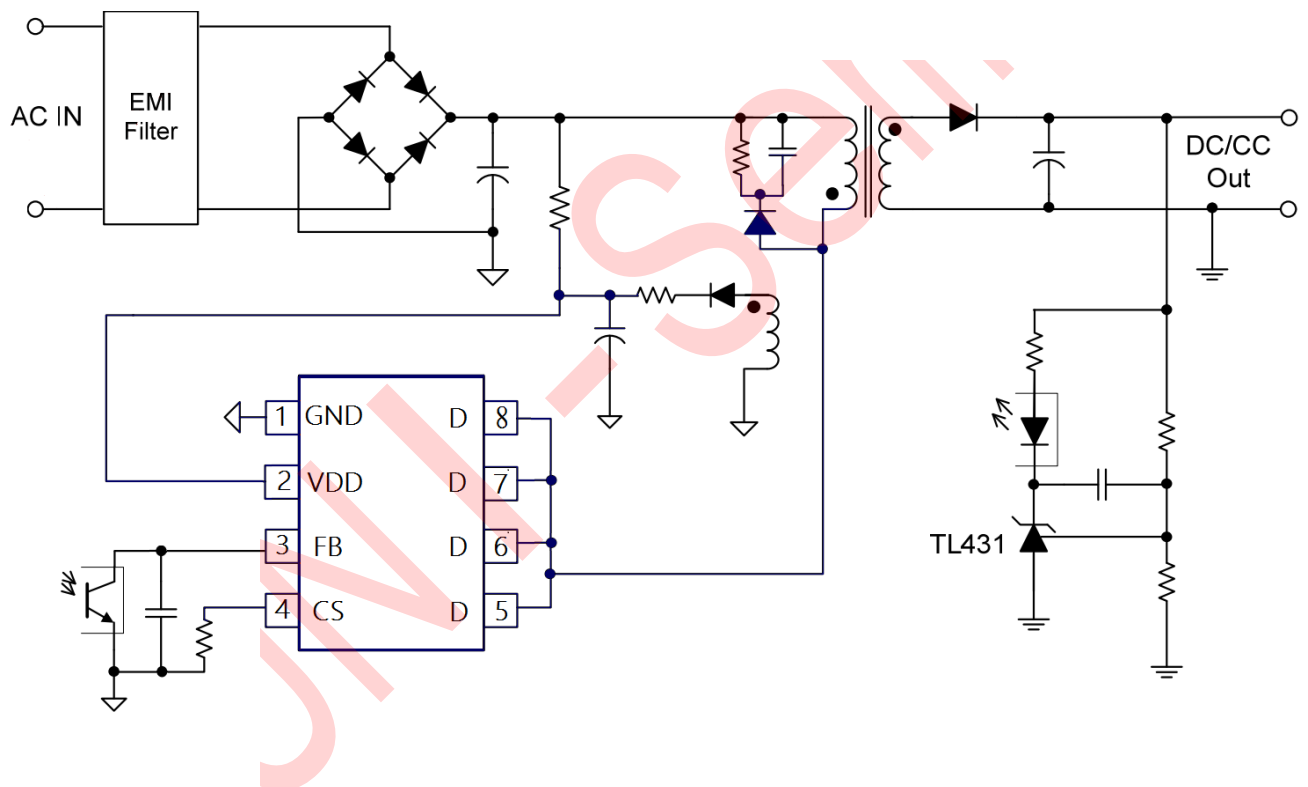

■ Block Diagram

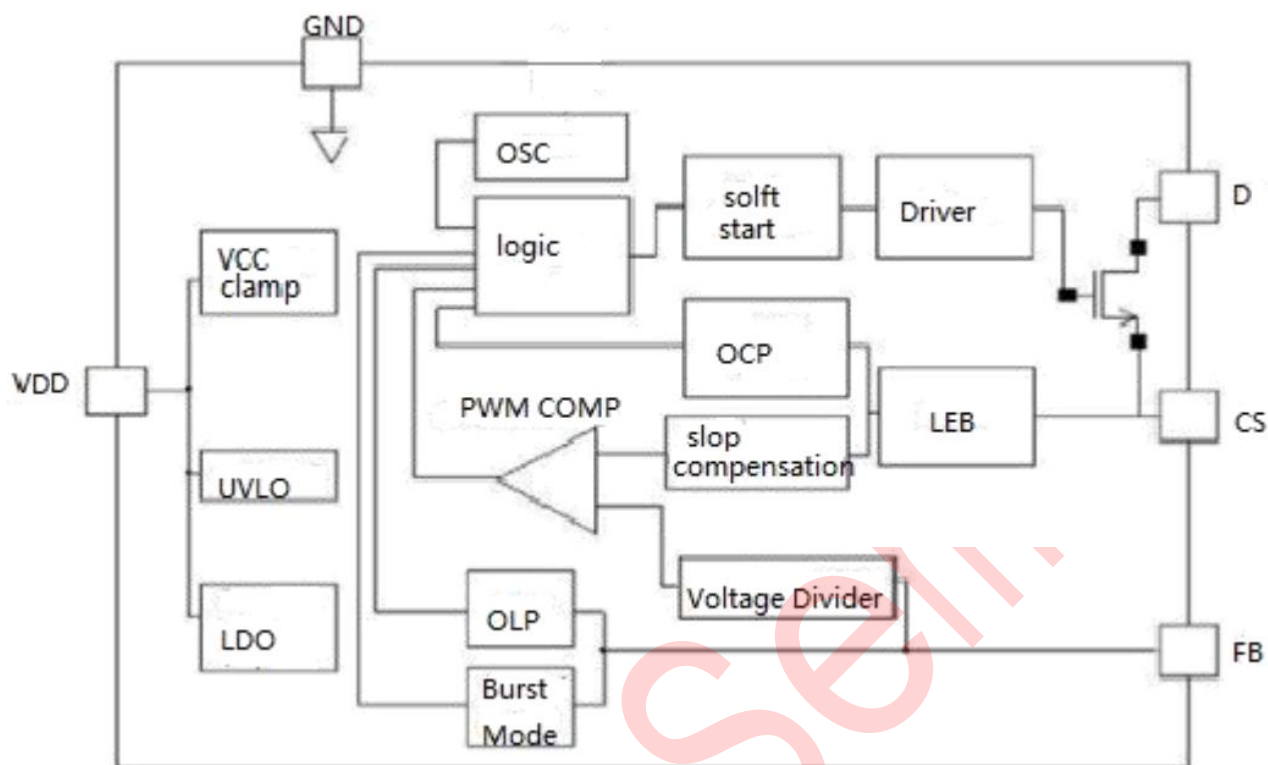

■ Absolute Maximum Ratings (Note 1)

Parameter	Value	Unit
VDD DC Supply Voltage	41	V
VDD DC Clamp Current	10	mA
FB, CS voltage range	-0.3 to 7	V
D voltage range	-0.3 to 630	V
Package Thermal Resistance (Junction to Ambient SOP-7)	165	°C/W
Maximum Junction Temperature	150	°C
Storage Temperature Range	-40 to 150	°C
Lead Temperature (Soldering, 10sec.)	260	°C
ESD Capability, HBM (Human Body Model)	2	kV
ESD Capability, MM (Machine Model)	150	V

■ Recommended Operation Conditions (Note 2)

Parameter	Value	Unit
Supply Voltage, VDD	9 to 41	V
Operating Ambient Temperature	-10 to 85	°C

■ **Electrical Characteristics** ($T_A=25^{\circ}\text{C}$, $V_{DD}=16\text{V}$, if not otherwise noted)

Symbol	Parameter	Test Conditions	Min	Typ.	Max	Unit
Supply Voltage Section(VDD Pin)						
I_{VDD_st}	Start-up current into VDD pin			3	10	μA
I_{VDD_Op}	Operation Current	$V_{FB}=2\text{V}$		1.5		mA
V_{DD_ON}	VDD Under Voltage Lockout Exit		13	13.4	16.5	V
V_{DD_OFF}	VDD Under Voltage Lockout Enter		6.8	7.8	8.2	V
V_{DD_OVP}	VDD OVP Threshold		41		43	V
V_{DD_Clamp}	VDD Zener Clamp Voltage	$I(V_{DD}) = 7 \text{ mA}$		44		V
Feedback Input Section (FB Pin)						
V_{FB_Open}	FB Open Voltage			5.7		V
I_{FB_Short}	FB Short Circuit Current	Short FB Pin to GND, Measure Current	90	150	300	μA
Z_{FB_IN}	FB Input Impedance			30		Kohm
V_{skip}	FB Under Voltage GATE Clock is OFF			1.0		V
V_{TH_OLP}	Power Limiting FB Threshold Voltage		2	2.5		V
T_{D_OLP}	Power Limiting Debounce Time			60		ms

Current Sense Input Section (CS Pin)						
T_{LEB}	CS Input Leading Edge Blanking Time			400		ns
$V_{CS(max)}$	Current limiting threshold		0.51	0.56	0.61	V
T_{D_OC}	Over Current Detection and Control Delay	GATE=1nF		70		ns
Oscillator Section						
F_{OSC}	Normal Oscillation Frequency		60	65	73	KHz
$\frac{\Delta F(shuffle)}{F_{OSC}}$	Frequency Shuffling Range		-4		4	%
D_{MAX}	Maximum Switching Duty Cycle			75		%
F_{Burst}	Burst Mode Base Frequency			25		KHz
On-Chip Thermal Shutdown						
T_{SD}	Thermal Shutdown	(Note 3)	---	165	--	°C
T_{RC}	Thermal Recovery	(Note 3)		140	--	°C
Power MOSFET Section (D Pin)						
BV_{DSS}	Power MOSFET Drain Source Breakdown Voltage	$V_{GS}=0V, I_D=250\mu A$	650			V
R_{dson}	Static Drain-Source On Resistance	$V_{GS}=10V, I_D=2A$		1.0		Ω

Note:

1. Stresses listed as the above "Maximum Ratings" may cause permanent damage to the device. These are for stress ratings. Functional operation of the device at these or any other conditions beyond those indicated in the operational sections of the specifications is not implied. Exposure to maximum rating conditions for extended periods may remain possibility to affect device reliability.
2. The device is not guaranteed to function outside its operating conditions.
3. Guaranteed by the Design.

■ Peration Description

U6620S combines a dedicated current mode PWM mode controller with 1R/650V MOSFEET. U6620S has high efficiency, low standby power consumption, low EMC and low cost.

- **System Start-Up Operation and IC Operation Current**

U6620S has very low start-up current that is less than 10uA. Therefore, a large resistor can be used in start-up circuit of switch power supply. This will minimize standby dissipation. The typical resistance of start-up resistor is 4M ohms.

The Operating current of U6620S is less than 1.5mA. Therefore, U6620S can have good efficiency.

- **Oscillator with Frequency Shuffling**

The frequency Shuffling is implemented in U6620S. The oscillation frequency is modulated with a random source so that the harmonic energy is spread out. The spread spectrum minimizes the conduction EMI and therefore reduces system design challenge.

- **Built-in Slope Compensation**

Slope compensation circuit adds voltage ramp onto the CS voltage according to PWM pulse width. This greatly improves the close loop stability at CCM and prevents the sub-harmonic oscillation and thus reduces the output ripple voltage. Slope compensation also help U6620S obtain the same output current in universal ac input voltage.

- **Current Sensing and Leading Edge Blanking (LEB)**

Cycle-by-Cycle current limitation is offered in U6620S. The switching current is detected by a resistor into the CS pin. An internal leading-edge

blanking circuit chops off the CS voltage spike at initial so that the external RC filtering on CS pin is no longer required. The current limiting comparator is disabled and thus cannot turn off the external MOSFET during the blanking period. PWM duty cycle is determined by the voltage in the CS pin and the FB pin.

- **Burst Mode Operation**

At zero load or light load condition, the main power dissipation in a switching mode power supply is from switching on the MOSFET, the core of transformer and the snubber circuit. The magnitude of power dissipation is proportional to the number of switching frequency within certain period. Less switching frequency can reduce the power dissipation. U6620S adjusts the switching frequency according to the loading condition. The PWM pulse width is kept greater than 1.2uS at any load condition. From light load to no load, the FB voltage drops. While the FB voltage is less than 1.1V, the gate pin output is disabled and kept low, while the FB voltage is higher than 1.2V, the gate output recovers to normal working mode. This is called 'burst mode'. To reduce audio noise, the switching frequency will be kept higher than 20KHz in burst mode.

- **Oscillator Operation**

The switching frequency is internally fixed at 65kHz. No external frequency setting components are required on PCB design.

- **On Chip Thermal Shutdown (OTP)**

When the IC temperature is over 165 °C , the IC shuts down. Only when the IC temperature drops to 140 °C, IC will restart.

- **Protection Controls**

U6620S has comprehensive protection functions, including Cycle-by-Cycle current limitation (OCP), Over Load Protection (OLP) and over voltage clamp, Under Voltage Lockout on VCC (UVLO), Over Temperature Protection (OTP).

- **Current limitation compensation**

To obtain the same output current capability, the OLP threshold voltage is compensated for the different input AC voltage. This function makes the current of OLP is in consistency whatever the AC input is (110V or 220V).

UNI - Semi

■ Package Dimensions

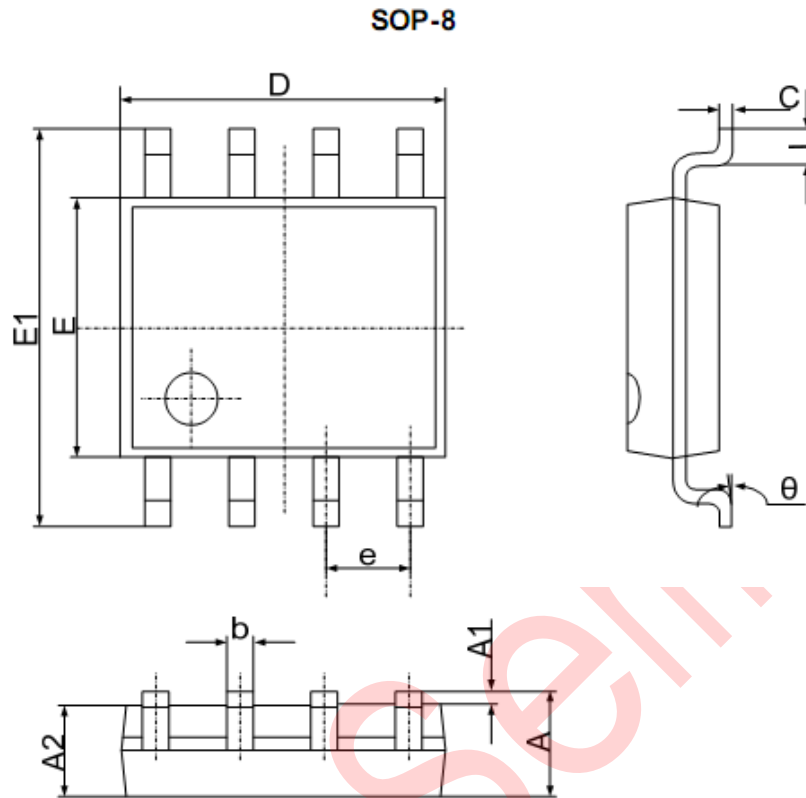

Symbol	Dimensions in Millimeters		Dimensions in Inches	
	Min	Max	Min	Max
A	1.350	1.750	0.053	0.069
A1	0.100	0.250	0.004	0.010
A2	1.350	1.550	0.053	0.061
b	0.330	0.510	0.013	0.020
c	0.170	0.250	0.006	0.010
D	4.700	5.100	0.185	0.200
E	3.800	4.000	0.150	0.157
E1	5.800	6.200	0.228	0.244
e	1.270 (BSC)		0.050 (BSC)	
L	0.400	1.270	0.016	0.050
θ	0°	8°	0°	8°

X-ON Electronics

Largest Supplier of Electrical and Electronic Components

Click to view similar products for [Switching Voltage Regulators](#) category:

Click to view products by [UNI-SEMI](#) manufacturer:

Other Similar products are found below :

[FAN53610AUC33X](#) [FAN53611AUC123X](#) [MP2374DS-LF-Z](#) [AP3602AKTR-G1](#) [NCP81108MNTXG](#) [NCP81109BMNTXG](#)
[FAN48610BUC45X](#) [FAN48617UC50X](#) [R3](#) [430464BB](#) [FAN53611AUC12X](#) [MAX809TTR](#) [NCV891234MW50R2G](#) [AST1S31PUR](#)
[NCP81103MNTXG](#) [NCP81203PMNTXG](#) [NCP81208MNTXG](#) [NCP81109GMNTXG](#) [SCY1751FCCT1G](#) [NCP81109JMNTXG](#)
[NCP81241MNTXG](#) [MP2388GQEU-Z](#) [MPQ4481GU-AEC1-P](#) [MPQ2171GJ-P](#) [IR3888MTRPBFAUMA1](#) [MPQ2171GJ-AEC1-P](#) [MP2171GJ-](#)
[P](#) [NCV1077CSTBT3G](#) [MP28160GC-Z](#) [LTM4691EV#PBF](#) [XCL207A123CR-G](#) [XDPE132G5CG000XUMA1](#) [XDPE12284C0000XUMA1](#)
[LTM4691IV#PBF](#) [MP5461GC-P](#) [MIC23356YFT-TR](#) [XC9236D08CER-G](#) [ISL95338IRTZ](#) [TPS55162QPWPRQ1](#) [MP3416GJ-P](#)
[BD9S201NUX-CE2](#) [ISL9113AIRAZ-T](#) [MP5461GC-Z](#) [MPQ2172GJ-AEC1-Z](#) [MPQ4415AGQB-Z](#) [MPQ4590GS-Z](#) [FAN53526UC224X](#) [S-](#)
[19903DA-A8T1U7](#) [S-19903CA-A6T8U7](#) [S-19915BA-A8T1U7](#)