



## 12N65

Power MOSFET

### 12A, 650V N-CHANNEL POWER MOSFET

#### DESCRIPTION

The UTC **12N65** are N-Channel enhancement mode power field effect transistors (MOSFET) which are produced by using UTC's proprietary, planar stripe and DMOS technology.

These devices are suited for high efficiency switch mode power supply. To minimize on-state resistance, provide superior switching performance and withstand high energy pulse in the avalanche and commutation mode, the advanced technology has been especially tailored.

#### FEATURES

- \*  $R_{DS(ON)} < 0.85\Omega$  @  $V_{GS} = 10V, I_D = 6.0A$
- \* Ultra low gate charge ( typical 42 nC )
- \* Low reverse transfer capacitance (  $C_{RSS} =$  typical 25 pF )
- \* Fast switching capability
- \* Avalanche energy specified
- \* Improved dv/dt capability, high ruggedness

#### SYMBOL

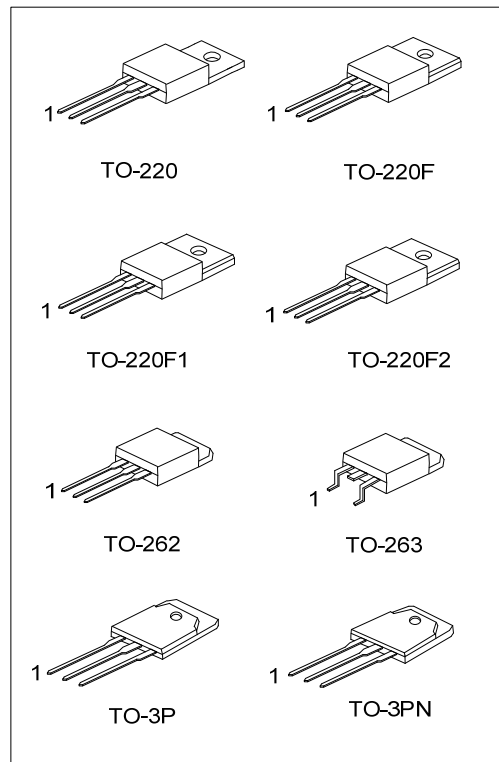
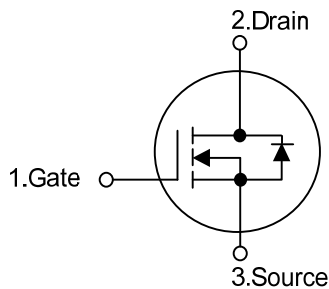

### ORDERING INFORMATION

Ordering Number		Package	Pin Assignment			Packing
Lead Free	Halogen Free		1	2	3	
12N65L-TA3-T	12N65G-TA3-T	TO-220	G	D	S	Tube
12N65L-TF1-T	12N65G-TF1-T	TO-220F1	G	D	S	Tube
12N65L-TF2-T	12N65G-TF2-T	TO-220F2	G	D	S	Tube
12N65L-TF3-T	12N65G-TF3-T	TO-220F	G	D	S	Tube
12N65L-T2Q-T	12N65G-T2Q-T	TO-262	G	D	S	Tube
12N65L-TQ2-T	12N65G-TQ2-T	TO-263	G	D	S	Tube
12N65L-TQ2-R	12N65G-TQ2-R	TO-263	G	D	S	Tape Reel
12N65L-T3P-T	12N65G-T3P-T	TO-3P	G	D	S	Tube
12N65L-T3N-T	12N65G-T3N-T	TO-3PN	G	D	S	Tube

Note: Pin Assignment: G: Gate D: Drain S: Source

<p>12N65G-TA3-T</p> <p>(1) Packing Type (2) Package Type (3) Green Package</p>	<p>(1) T: Tube, R: Tape Reel (2) TA3: TO-220, TF1: TO-220F1, TF2: TO-220F2 TF3: TO-220F, T2Q: TO-262, TQ2: TO-263 T3P: TO-3P, T3N: TO-3PN (3) G: Halogen Free and Lead Free, L: Lead Free</p>
----------------------------------------------------------------------------------------	---------------------------------------------------------------------------------------------------------------------------------------------------------------------------------------------------------------

### MARKING

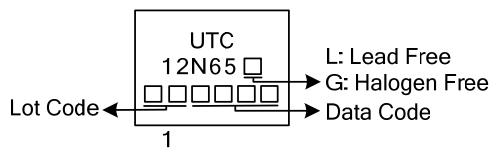

■ ABSOLUTE MAXIMUM RATINGS ( $T_C = 25^\circ\text{C}$ , unless otherwise specified)

PARAMETER		SYMBOL	RATINGS	UNIT
Drain-Source Voltage		$V_{DSS}$	650	V
Gate-Source Voltage		$V_{GSS}$	$\pm 30$	V
Avalanche Current (Note 2)		$I_{AR}$	12	A
Drain Current	Continuous	$I_D$	12	A
	Pulsed (Note 2)	$I_{DM}$	48	A
Avalanche Energy	Single Pulsed (Note 3)	$E_{AS}$	790	mJ
	Repetitive (Note 2)	$E_{AR}$	24	mJ
Peak Diode Recovery $dv/dt$ (Note 4)		$dv/dt$	4.5	V/ns
Power Dissipation	TO-220/TO-262 TO-263	$P_D$	225	W
	TO-220F/TO-220F1		51	W
	TO-220F2		54	W
	TO-3P/TO-3PN		260	W
Junction Temperature		$T_J$	+150	$^\circ\text{C}$
Operating Temperature		$T_{OPR}$	-55 ~ +150	$^\circ\text{C}$
Storage Temperature		$T_{STG}$	-55 ~ +150	$^\circ\text{C}$

Notes: 1. Absolute maximum ratings are those values beyond which the device could be permanently damaged.

Absolute maximum ratings are stress ratings only and functional device operation is not implied.

2. Repetitive Rating : Pulse width limited by maximum junction temperature.

3.  $L = 10\text{mH}$ ,  $I_{AS} = 12\text{A}$ ,  $V_{DD} = 50\text{V}$ ,  $R_G = 25\Omega$ , Starting  $T_J = 25^\circ\text{C}$

4.  $I_{SD} \leq 12\text{A}$ ,  $di/dt \leq 200\text{A/s}$ ,  $V_{DD} \leq BV_{DSS}$  Starting  $T_J = 25^\circ\text{C}$

■ THERMAL DATA

PARAMETER		SYMBOL	RATING	UNIT	
Junction to Ambient	TO-220/TO-220F TO-220F1/TO-220F2 TO-262/TO-263	$\theta_{JA}$	62.5	$^\circ\text{C/W}$	
	TO-3P/TO-3PN		40	$^\circ\text{C/W}$	
	Junction to Case		$\theta_{JC}$	0.56	$^\circ\text{C/W}$
				TO-220/TO-262 TO-263	2.43
TO-220F/TO-220F1		2.31		$^\circ\text{C/W}$	
TO-220F2		0.48		$^\circ\text{C/W}$	
TO-3P/TO-3PN					

■ ELECTRICAL CHARACTERISTICS (T<sub>C</sub>=25°C, unless otherwise specified)

PARAMETER	SYMBOL	TEST CONDITIONS	MIN	TYP	MAX	UNIT
<b>OFF CHARACTERISTICS</b>						
Drain-Source Breakdown Voltage	BV <sub>DSS</sub>	V <sub>GS</sub> = 0 V, I <sub>D</sub> = 250 μA	650			V
Drain-Source Leakage Current	I <sub>DSS</sub>	V <sub>DS</sub> = 650 V, V <sub>GS</sub> = 0 V			1	μA
Gate-Source Leakage Current	I <sub>GSS</sub>	V <sub>GS</sub> = ±30 V, V <sub>DS</sub> = 0 V			±100	nA
Breakdown Voltage Temperature Coefficient	ΔBV <sub>DSS</sub> /ΔT <sub>J</sub>	I <sub>D</sub> =250μA, Referenced to 25°C		0.7		V/°C
<b>ON CHARACTERISTICS</b>						
Gate Threshold Voltage	V <sub>GS(TH)</sub>	V <sub>DS</sub> = V <sub>GS</sub> , I <sub>D</sub> = 250μA	2.0		4.0	V
Static Drain-Source On-State Resistance	R <sub>DS(ON)</sub>	V <sub>GS</sub> = 10V, I <sub>D</sub> = 6.0A		0.65	0.85	Ω
<b>DYNAMIC CHARACTERISTICS</b>						
Input Capacitance	C <sub>ISS</sub>	V <sub>DS</sub> = 25 V, V <sub>GS</sub> = 0 V, f = 1MHz		1480	1900	pF
Output Capacitance	C <sub>OSS</sub>			200	270	pF
Reverse Transfer Capacitance	C <sub>RSS</sub>			25	35	pF
<b>SWITCHING CHARACTERISTICS</b>						
Total Gate Charge	Q <sub>G</sub>	V <sub>DS</sub> = 520V, I <sub>D</sub> = 12A, V <sub>GS</sub> = 10 V (Note 1, 2)		42	54	nC
Gate-Source Charge	Q <sub>GS</sub>			8.6		nC
Gate-Drain Charge	Q <sub>GD</sub>			21		nC
Turn-On Delay Time	t <sub>D(ON)</sub>	V <sub>DD</sub> = 325V, I <sub>D</sub> = 12A, R <sub>G</sub> = 25Ω (Note 1, 2)		30	70	ns
Turn-On Rise Time	t <sub>R</sub>			115	240	ns
Turn-Off Delay Time	t <sub>D(OFF)</sub>			95	200	ns
Turn-Off Fall Time	t <sub>F</sub>			85	180	ns
<b>SOURCE- DRAIN DIODE RATINGS AND CHARACTERISTICS</b>						
Maximum Continuous Drain-Source Diode Forward Current	I <sub>S</sub>				12	A
Maximum Pulsed Drain-Source Diode Forward Current	I <sub>SM</sub>				48	A
Drain-Source Diode Forward Voltage	V <sub>SD</sub>	V <sub>GS</sub> = 0 V, I <sub>S</sub> = 12A			1.4	V
Reverse Recovery Time	t <sub>rr</sub>	V <sub>GS</sub> = 0 V, I <sub>S</sub> = 12A, dI <sub>F</sub> /dt = 100 A/μs (Note 1)		380		ns
Reverse Recovery Charge	Q <sub>rr</sub>				3.5	

Notes: 1. Pulse Test : Pulse width ≤300μs, Duty cycle ≤ 2%

2. Essentially independent of operating temperature

■ TEST CIRCUITS AND WAVEFORMS

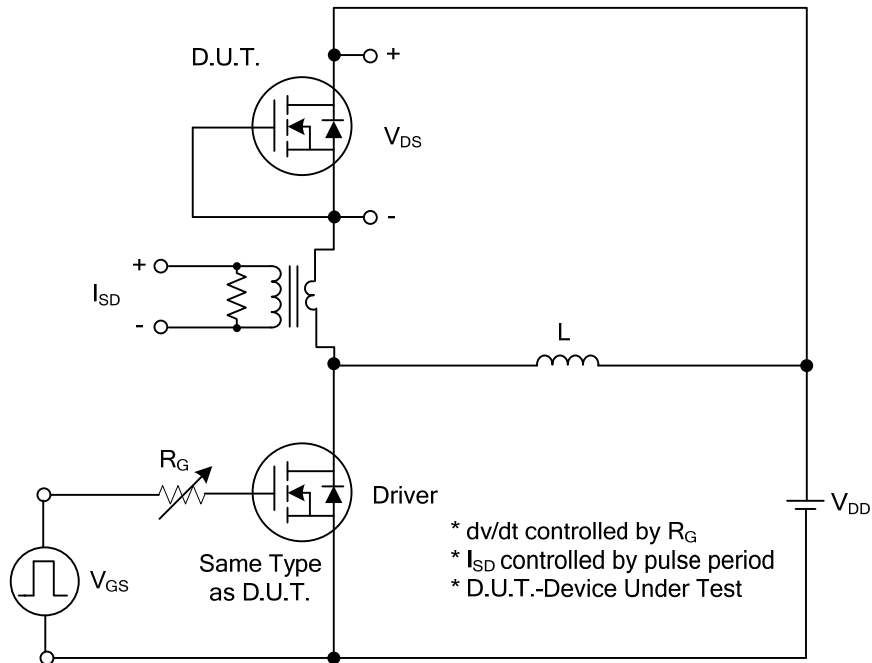

Peak Diode Recovery  $dv/dt$  Test Circuit

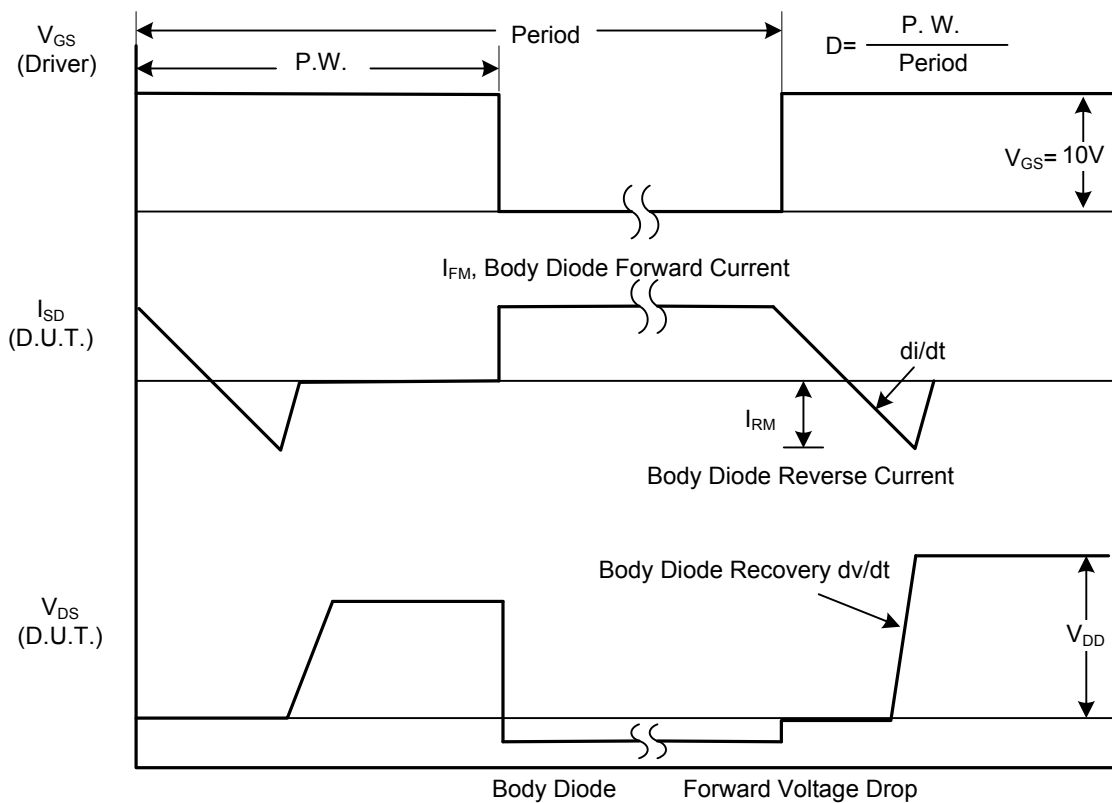

Peak Diode Recovery  $dv/dt$  Waveforms

## TEST CIRCUITS AND WAVEFORMS

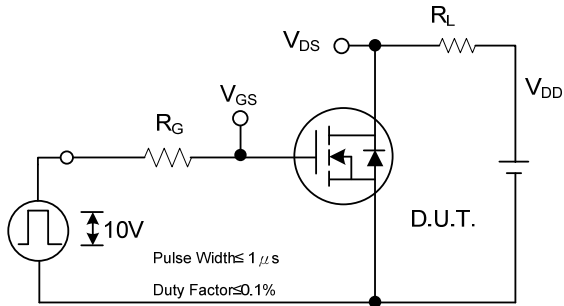

**Switching Test Circuit**

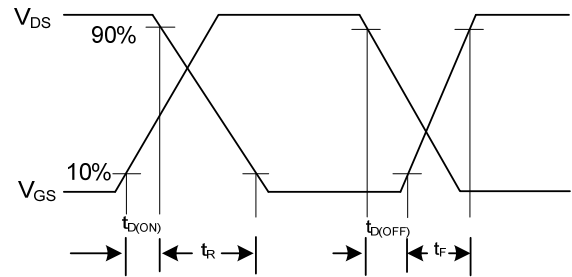

**Switching Waveforms**

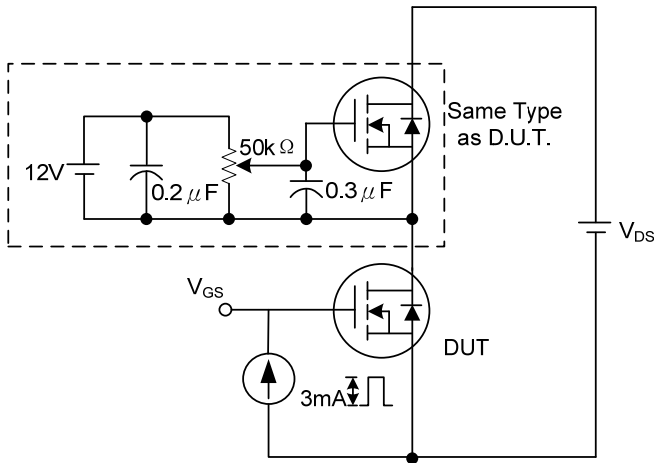

**Gate Charge Test Circuit**

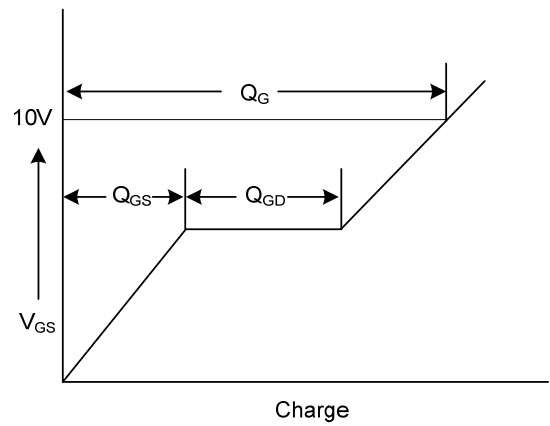

**Gate Charge Waveform**

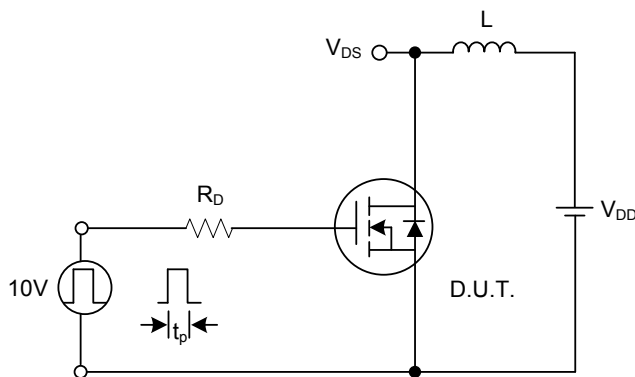

**Unclamped Inductive Switching Test Circuit**

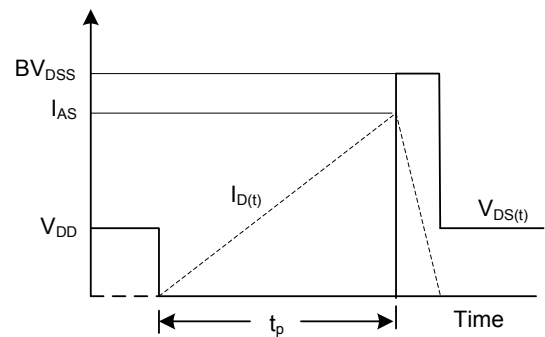

**Unclamped Inductive Switching Waveforms**

## TYPICAL CHARACTERISTICS

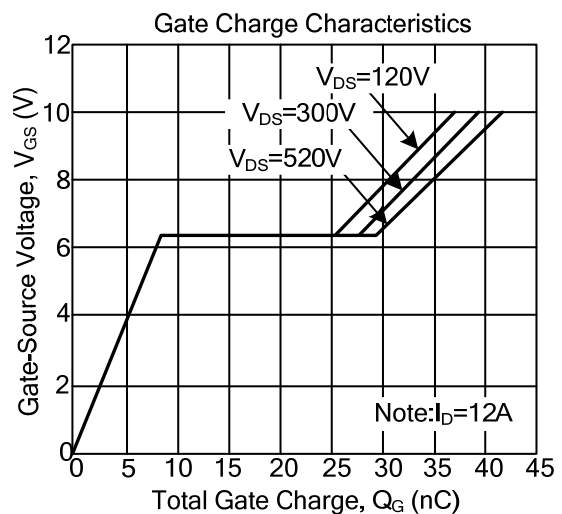
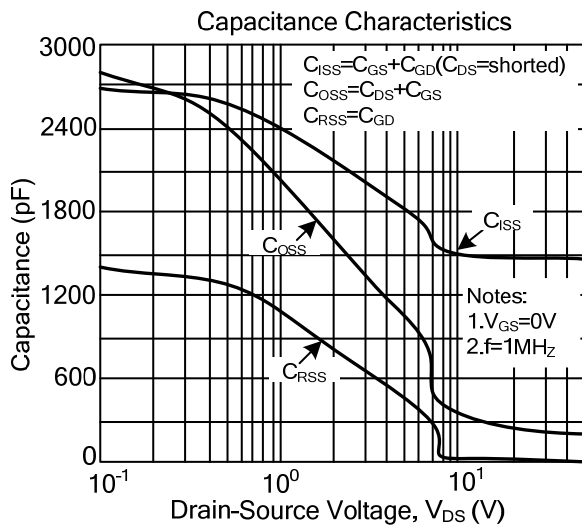
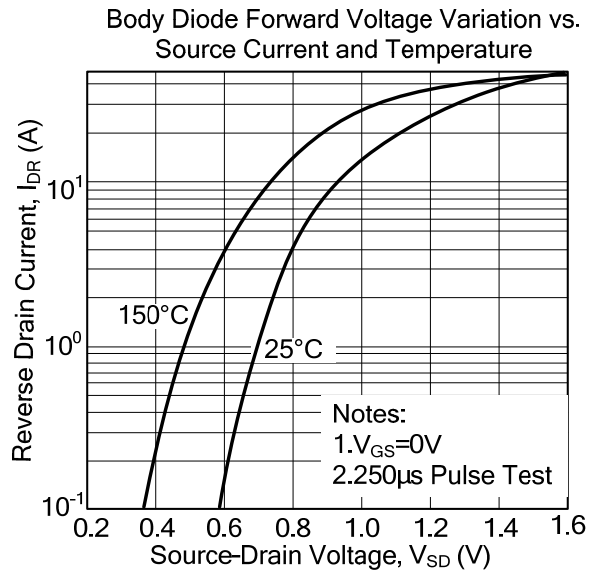
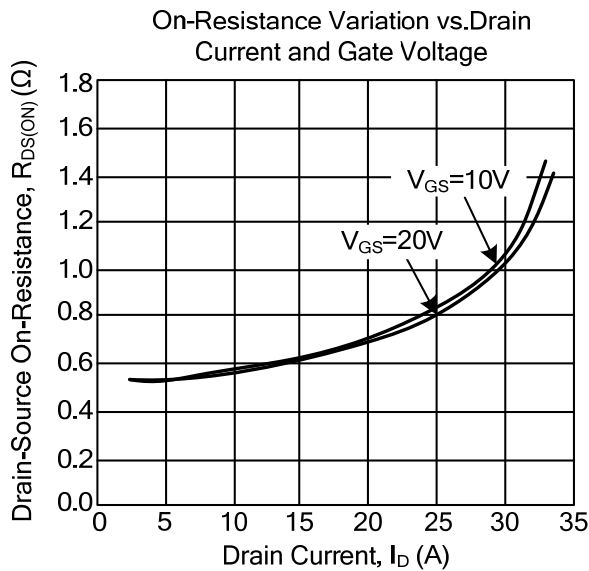
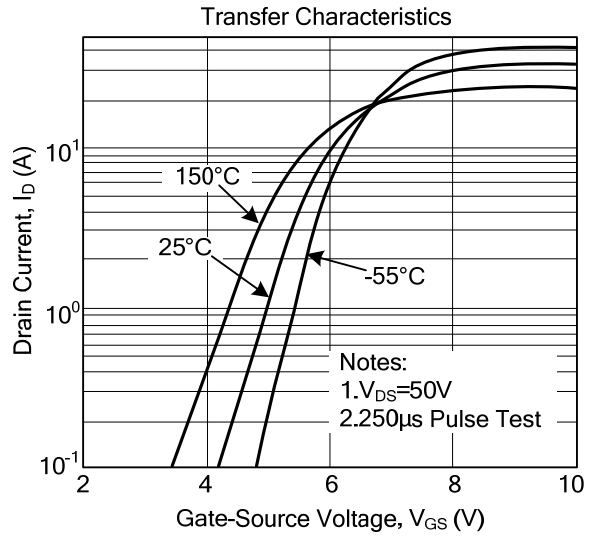
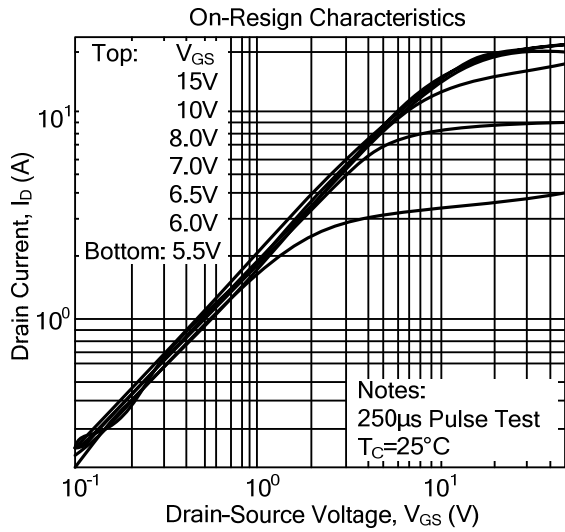

## ■ TYPICAL CHARACTERISTICS

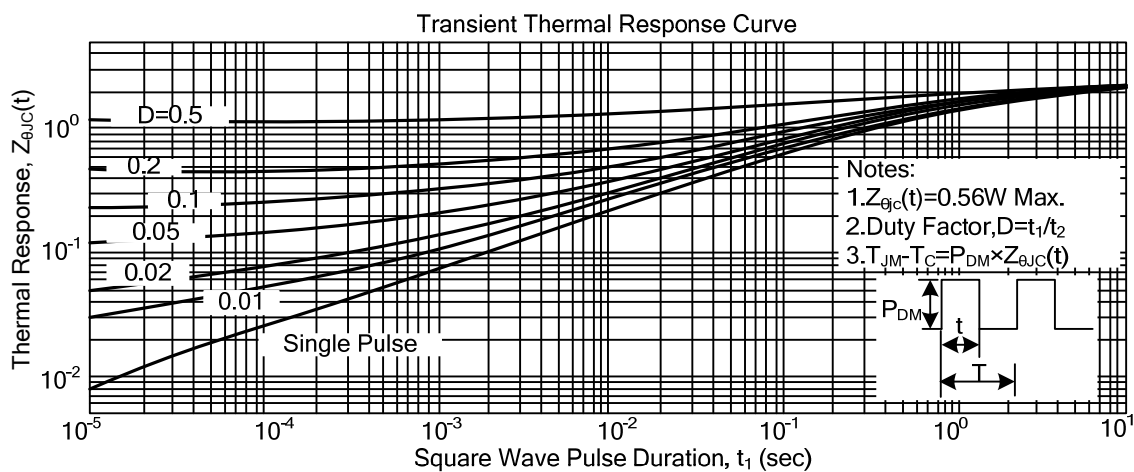
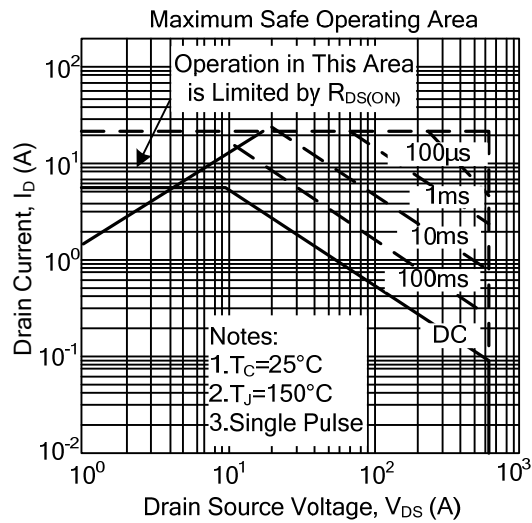

UTC assumes no responsibility for equipment failures that result from using products at values that exceed, even momentarily, rated values (such as maximum ratings, operating condition ranges, or other parameters) listed in products specifications of any and all UTC products described or contained herein. UTC products are not designed for use in life support appliances, devices or systems where malfunction of these products can be reasonably expected to result in personal injury. Reproduction in whole or in part is prohibited without the prior written consent of the copyright owner. UTC reserves the right to make changes to information published in this document, including without limitation specifications and product descriptions, at any time and without notice. This document supersedes and replaces all information supplied prior to the publication hereof.



## X-ON Electronics

Largest Supplier of Electrical and Electronic Components

*Click to view similar products for [MOSFET](#) category:*

*Click to view products by [Unisonic](#) manufacturer:*

Other Similar products are found below :

[IRFD120](#) [JANTX2N5237](#) [BUK455-60A/B](#) [MIC4420CM-TR](#) [VN1206L](#) [NDP4060](#) [SI4482DY](#) [IPS70R2K0CEAKMA1](#) [SQD23N06-31L-GE3](#)  
[TK16J60W,S1VQ\(O](#) [2SK2614\(TE16L1,Q\)](#) [DMN1017UCP3-7](#) [DMN1053UCP4-7](#) [SQJ469EP-T1-GE3](#) [NTE2384](#) [DMC2700UDMQ-7](#)  
[DMN2080UCB4-7](#) [DMN61D9UWQ-13](#) [US6M2GTR](#) [DMN31D5UDJ-7](#) [DMP22D4UFO-7B](#) [DMN1006UCA6-7](#) [DMN16M9UCA6-7](#)  
[STF5N65M6](#) [IRF40H233XTMA1](#) [STU5N65M6](#) [DMN6022SSD-13](#) [DMN13M9UCA6-7](#) [DMTH10H4M6SPS-13](#) [DMN2990UFB-7B](#)  
[IPB80P04P405ATMA2](#) [2N7002W-G](#) [MCAC30N06Y-TP](#) [MCQ7328-TP](#) [BXP7N65D](#) [BXP4N65F](#) [AOL1454G](#) [WMJ80N60C4](#) [BXP2N20L](#)  
[BXP2N65D](#) [BXT1150N10J](#) [BXT1700P06M](#) [TSM60NB380CP](#) [ROG](#) [RQ7L055BGTCR](#) [DMNH15H110SK3-13](#) [SLF10N65ABV2](#)  
[BSO203SP](#) [BSO211P](#) [IPA60R230P6](#) [IPA60R460CE](#)