



12P10

Power MOSFET

9.4A, 100V P-CHANNEL POWER MOSFET

DESCRIPTION

The **12P10** uses advanced proprietary, planar stripe, DMOS technology to provide excellent $R_{DS(ON)}$, low gate charge and operation with low gate voltages. This device is suitable to be used in low voltage applications such as audio amplifier, high efficiency switching DC/DC converters, and DC motor control.

FEATURES

- * $R_{DS(ON)} < 0.29\Omega$ @ $V_{GS} = -10V, I_D = -4.7A$
- * Low capacitance
- * Low gate charge
- * Fast switching capability
- * Avalanche energy specified

SYMBOL

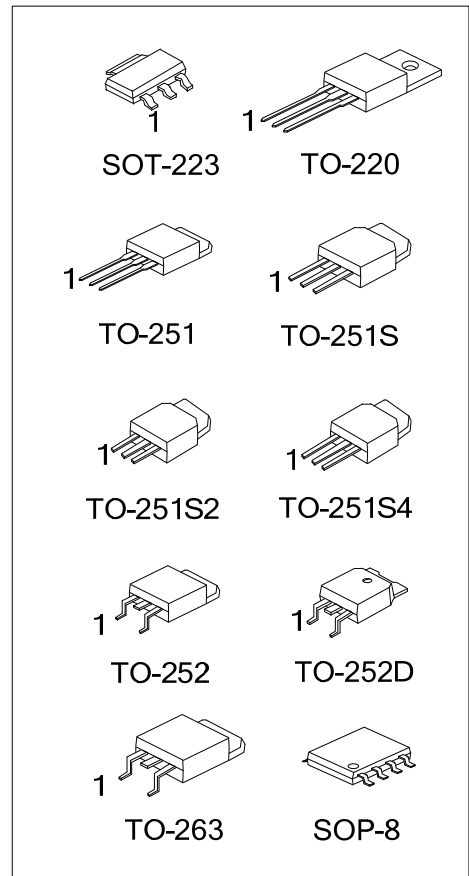
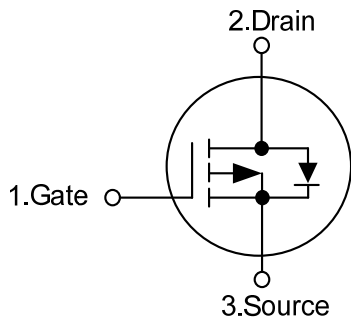

ORDERING INFORMATION

Ordering Number		Package	Pin Assignment								Packing
Lead Free	Halogen Free		1	2	3	4	5	6	7	8	
-	12P10G-AA3-R	SOT-223	G	D	S	-	-	-	-	-	Tape Reel
12P10L-TA3-T	12P10G-TA3-T	TO-220	G	D	S	-	-	-	-	-	Tube
12P10L-TM3-T	12P10G-TM3-T	TO-251	G	D	S	-	-	-	-	-	Tube
12P10L-TMS-T	12P10G-TMS-T	TO-251S	G	D	S	-	-	-	-	-	Tube
12P10L-TMS2-T	12P10G-TMS2-T	TO-251S2	G	D	S	-	-	-	-	-	Tube
12P10L-TMS4-T	12P10G-TMS4-T	TO-251S4	G	D	S	-	-	-	-	-	Tube
12P10L-TN3-R	12P10G-TN3-R	TO-252	G	D	S	-	-	-	-	-	Tape Reel
12P10L-TND-R	12P10G-TND-R	TO-252D	G	D	S	-	-	-	-	-	Tape Reel
12P10L-TQ2-R	12P10G-TQ2-R	TO-263	G	D	S	-	-	-	-	-	Tape Reel
12P10L-TQ2-T	12P10G-TQ2-T	TO-263	G	D	S	-	-	-	-	-	Tube
-	12P10G-S08-R	SOP-8	S	S	S	G	D	D	D	D	Tape Reel

Note: Pin Assignment: G: Gate D: Drain S: Source

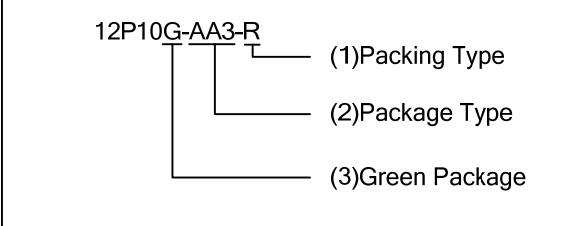
 <p>12P10G-AA3-R</p> <ul style="list-style-type: none"> (1) Packing Type (2) Package Type (3) Green Package 	<p>(1) R: Tape Reel, T: Tube (2) AA3: SOT-223, TA3: TO-220, TM3: TO-251, TMS: TO-251S, TMS2: TO-251S2, TMS4: TO-251S4 TN3: TO-252, TND: TO-252D, TQ2: TO-263 S08: SOP-8 (3) G: Halogen Free and Lead Free, L: Lead Free</p>
--	---

MARKING

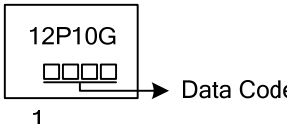
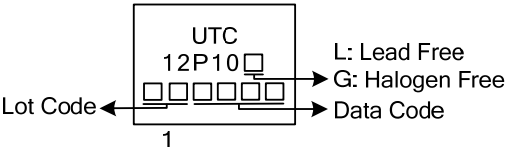
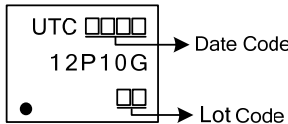
PACKAGE	MARKING
SOT-223	
TO-220 TO-251 TO-251S TO-251S2	<div style="display: flex; justify-content: space-between;"> <div style="text-align: center;"> TO-251S4 TO-252 TO-252D TO-263 </div> <div style="text-align: center;">  </div> </div>
SOP-8	

■ ABSOLUTE MAXIMUM RATINGS ($T_C=25^\circ\text{C}$, unless otherwise specified)

PARAMETER		SYMBOL	RATINGS	UNIT
Drain-Source Voltage		V_{DSS}	-100	V
Gate-Source Voltage		V_{GSS}	± 30	V
Continuous Drain Current		I_D	-9.4	A
Pulsed Drain Current (Note 2)		I_{DM}	-37.6	A
Avalanche Current (Note 2)		I_{AR}	-9.4	A
Single Pulsed Avalanche Energy (Note 3)		E_{AS}	280	mJ
Repetitive Avalanche Energy (Note 2)		E_{AR}	5.0	mJ
Power Dissipation	TO-220/TO-263	P_D	73	W
	TO-251/TO-251S TO-251S2/TO-251S4 TO-252/TO-252D		50	W
	SOT-223		8	W
	SOP-8		5	W
Junction Temperature		T_J	+150	$^\circ\text{C}$
Storage Temperature		T_{STG}	-55 ~ +150	$^\circ\text{C}$

Notes: 1. Absolute maximum ratings are those values beyond which the device could be permanently damaged.

Absolute maximum ratings are stress ratings only and functional device operation is not implied.

2. Pulse width limited by $T_{J(MAX)}$

3. $L=6.3\text{mH}$, $I_{AS}=-9.4\text{A}$, $V_{DD}=-25\text{V}$, $R_G=25\Omega$, Starting $T_J=25^\circ\text{C}$

4. $I_{SD}\leq-11.5\text{A}$, $di/dt\leq 300\mu\text{A/V s}$, $V_{DD}\leq BV_{DSS}$, Starting $T_J=25^\circ\text{C}$

■ THERMAL DATA

PARAMETER		SYMBOL	RATINGS	UNIT
Junction to Ambient	TO-220/TO-263	θ_{JA}	62.5	$^\circ\text{C/W}$
	TO-251/TO-251S TO-251S2/TO-251S4 TO-252/TO-252D		110	$^\circ\text{C/W}$
	TO-263		62.5	$^\circ\text{C/W}$
	SOT-223		125	$^\circ\text{C/W}$
	SOP-8		150	$^\circ\text{C/W}$
Junction to Case	TO-220/TO-263	θ_{JC}	1.9	$^\circ\text{C/W}$
	TO-251/TO-251S TO-251S2/TO-251S4 TO-252/TO-252D		2.5	$^\circ\text{C/W}$
	SOT-223		14	$^\circ\text{C/W}$
	SOP-8		25	$^\circ\text{C/W}$

■ ELECTRICAL CHARACTERISTICS (T_C=25°C, unless otherwise specified)

PARAMETER	SYMBOL	TEST CONDITIONS	MIN	TYP	MAX	UNIT
OFF CHARACTERISTICS						
Drain-Source Breakdown Voltage	BV _{DSS}	V _{GS} =0 V, I _D =-250μA	-100			V
Drain-Source Leakage Current	I _{DSS}	V _{DS} =-100V, V _{GS} =0V			-1	μA
		V _{DS} =-100V, T _C =125°C			-10	μA
Gate-Source Leakage Current	I _{GSS}	V _{DS} =0V, V _{GS} =±30V			±100	nA
ON CHARACTERISTICS						
Gate Threshold Voltage	V _{GS(TH)}	V _{DS} =V _{GS} , I _D =-250μA	-2.0		-4.0	V
Static Drain-Source On-Resistance	R _{DS(ON)}	V _{GS} =-10V, I _D =-4.7A		0.24	0.29	Ω
Forward Transconductance	g _{FS}	V _{DS} =-40V, I _D =-4.7A (Note 1)		6.3		S
DYNAMIC PARAMETERS						
Input Capacitance	C _{ISS}	V _{DS} =-25V, V _{GS} =0V, f=1.0MHz		570	800	pF
Output Capacitance	C _{OSS}			115	290	pF
Reverse Transfer Capacitance	C _{RSS}			30	85	pF
SWITCHING PARAMETERS						
Total Gate Charge	Q _G	V _{DS} =-50V, I _D =-1.3A, V _{GS} =-10V(Note 1, 2)		21	27	nC
Gate Source Charge	Q _{GS}			4.6		nC
Gate Drain Charge	Q _{GD}			4		nC
Turn-ON Delay Time	t _{D(ON)}	V _{DD} =-30V, I _D =-0.5A, R _G =25Ω (Note 1, 2)		40	50	ns
Turn-ON Rise Time	t _R			64	100	ns
Turn-OFF Delay Time	t _{D(OFF)}			255	275	ns
Turn-OFF Fall-Time	t _F			70	90	ns
SOURCE- DRAIN DIODE RATINGS AND CHARACTERISTICS						
Diode Forward Voltage	V _{SD}	V _{GS} =0V, I _S =-9.4A			-4.0	V
Maximum Body-Diode Continuous Current	I _S				-9.4	A
Maximum Pulsed Drain-Source Diode Forward Current	I _{SM}				-37.6	A

Notes: 1. Pulse Test : Pulse width ≤ 300μs, Duty cycle ≤ 2%
2. Essentially independent of operating temperature

■ TEST CIRCUITS AND WAVEFORMS

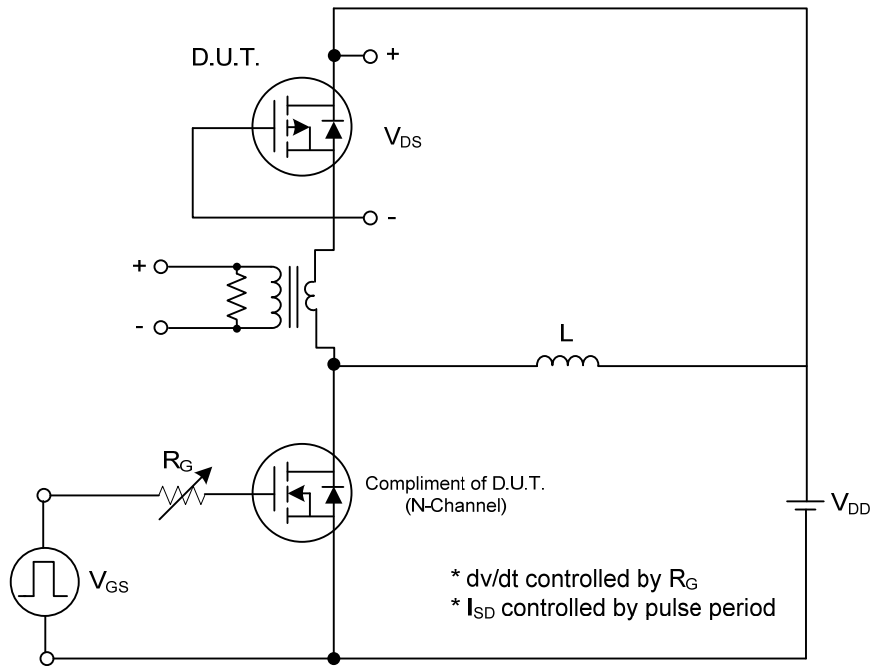

Peak Diode Recovery dv/dt Test Circuit

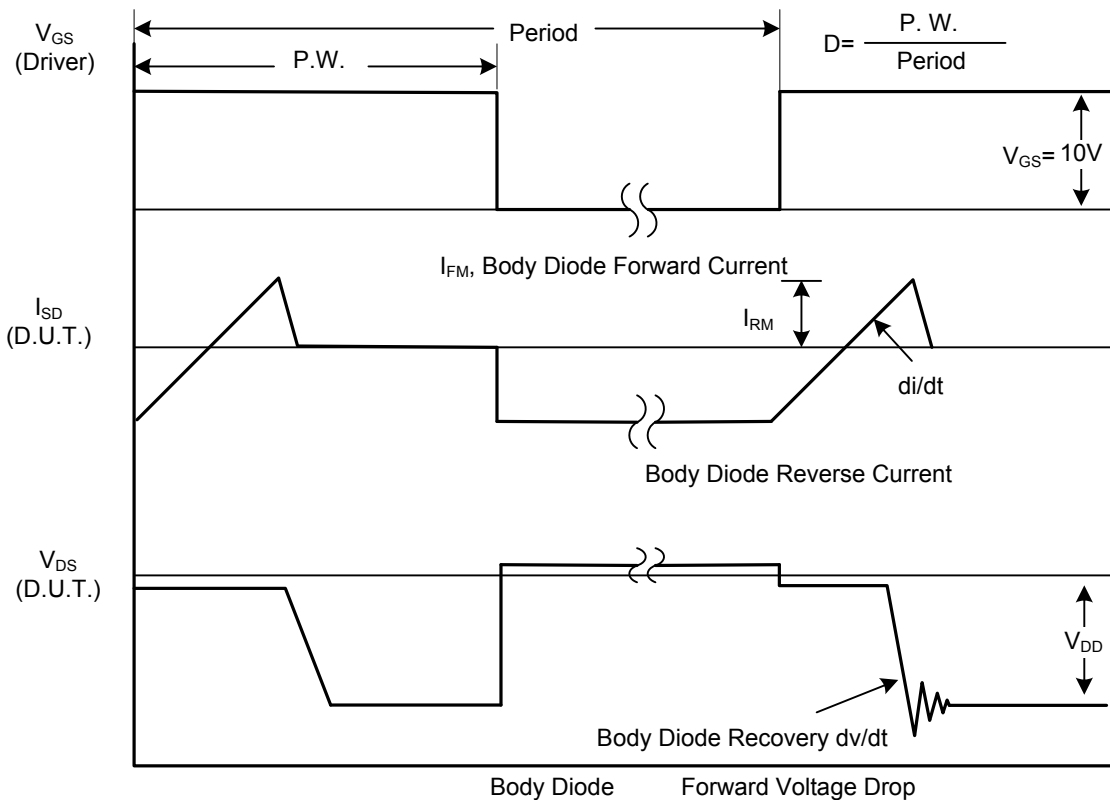

Peak Diode Recovery dv/dt Waveforms

■ TEST CIRCUITS AND WAVEFORMS (Cont.)

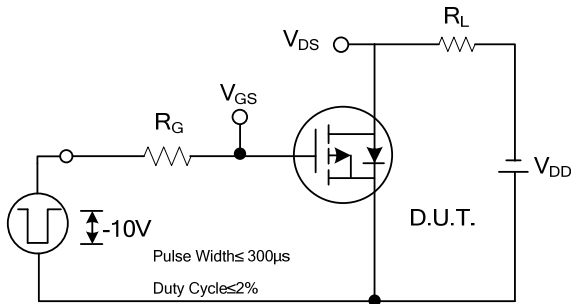

Switching Test Circuit

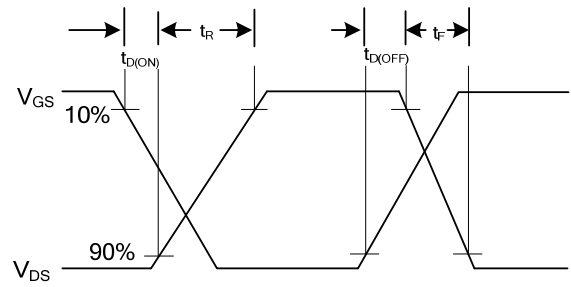

Switching Waveforms

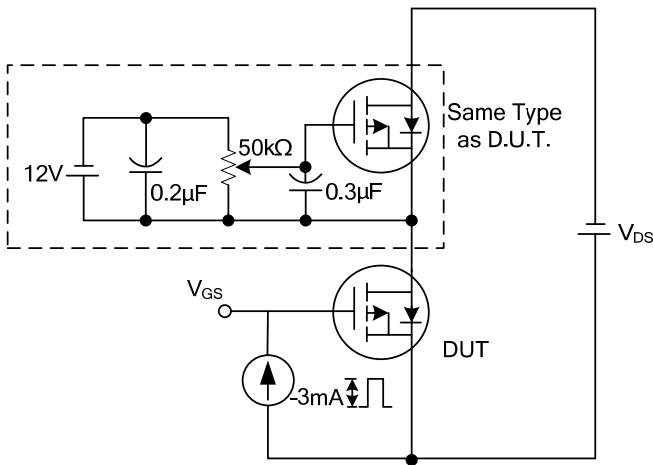

Gate Charge Test Circuit

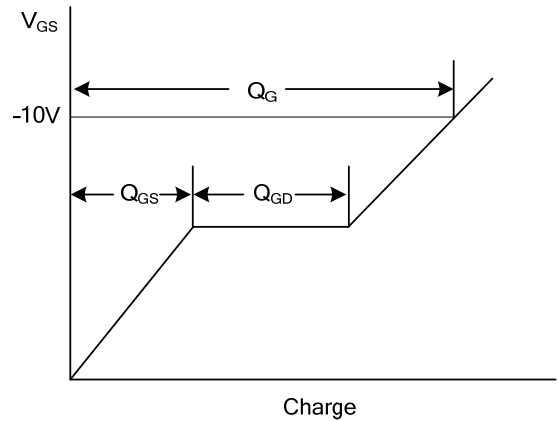

Gate Charge Waveform

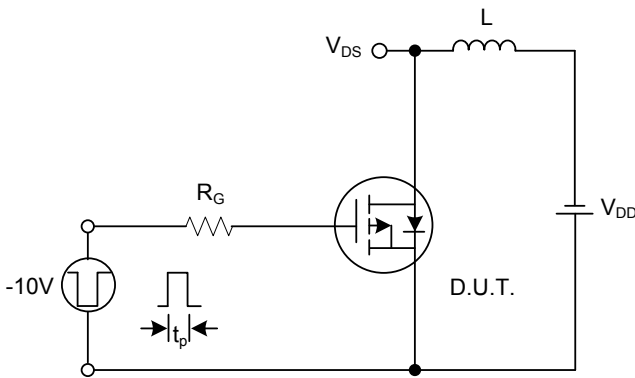

Unclamped Inductive Switching Test Circuit

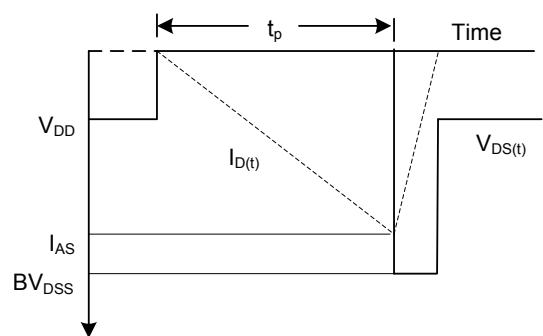

Unclamped Inductive Switching Waveforms

TYPICAL CHARACTERISTICS

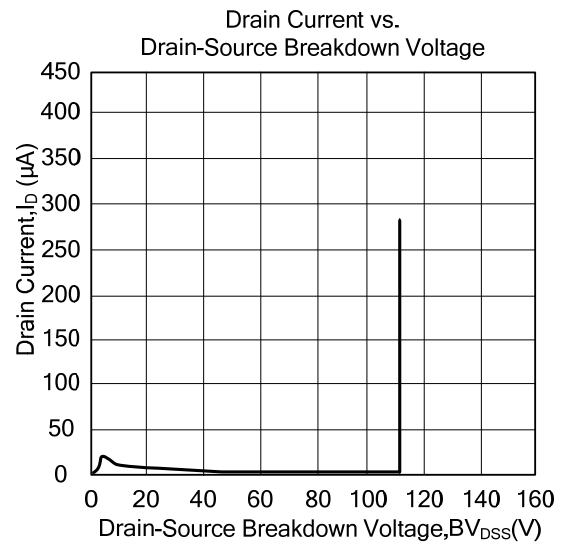
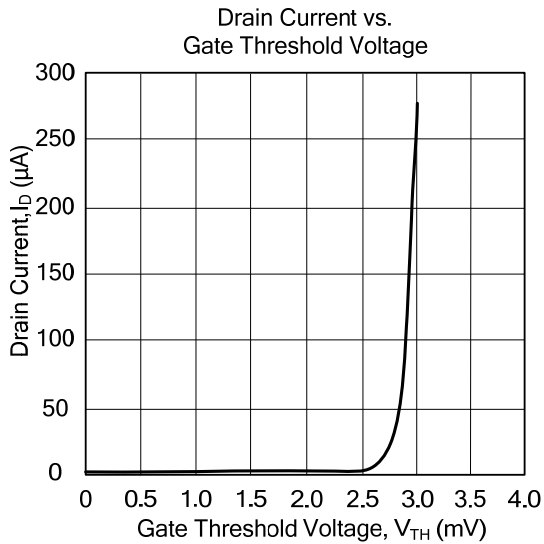
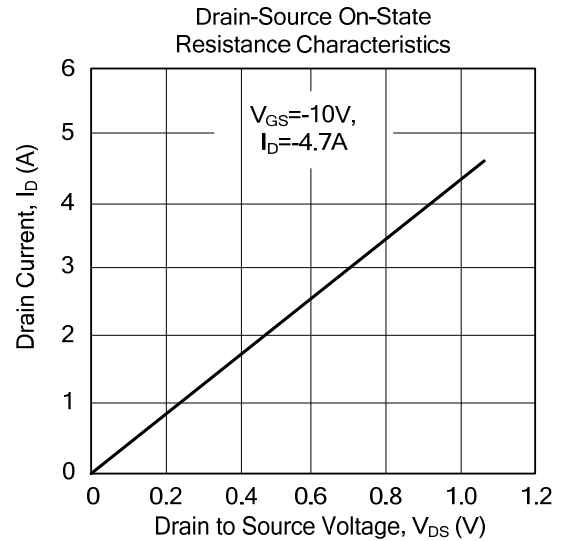
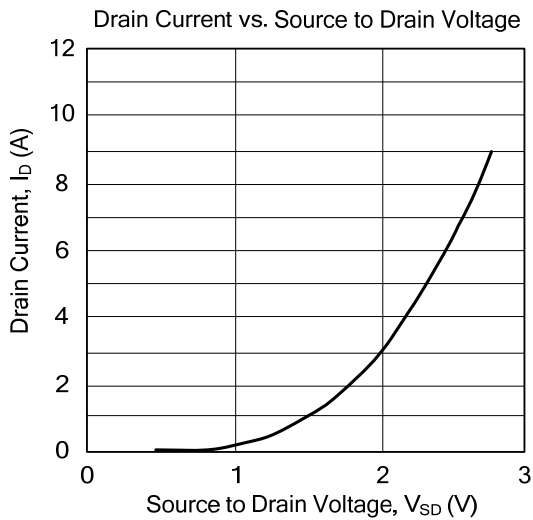

UTC assumes no responsibility for equipment failures that result from using products at values that exceed, even momentarily, rated values (such as maximum ratings, operating condition ranges, or other parameters) listed in products specifications of any and all UTC products described or contained herein. UTC products are not designed for use in life support appliances, devices or systems where malfunction of these products can be reasonably expected to result in personal injury. Reproduction in whole or in part is prohibited without the prior written consent of the copyright owner. The information presented in this document does not form part of any quotation or contract, is believed to be accurate and reliable and may be changed without notice.

X-ON Electronics

Largest Supplier of Electrical and Electronic Components

Click to view similar products for [MOSFET](#) category:

Click to view products by [Unisonic](#) manufacturer:

Other Similar products are found below :

[614233C](#) [648584F](#) [FDPF9N50NZ](#) [IRFD120](#) [IRFF430](#) [JANTX2N5237](#) [2N7000](#) [FCA20N60_F109](#) [FDZ595PZ](#) [2SK2267\(Q\)](#) [2SK2545\(Q,T\)](#)
[405094E](#) [423220D](#) [MIC4420CM-TR](#) [VN1206L](#) [614234A](#) [715780A](#) [SSM6J414TU,LF\(T](#) [751625C](#) [PSMN4R2-30MLD](#)
[TK31J60W5,S1VQ\(O](#) [2SK2614\(TE16L1,Q\)](#) [DMN1017UCP3-7](#) [EFC2J004NUZTDG](#) [FCAB21350L1](#) [P85W28HP2F-7071](#) [DMN1053UCP4-7](#)
[NTE2384](#) [NTE2969](#) [NTE6400A](#) [DMN61D9UWQ-13](#) [US6M2GTR](#) [DMN31D5UDJ-7](#) [SSM6P54TU,LF](#) [DMP22D4UFO-7B](#)
[IPS60R3K4CEAKMA1](#) [DMN1006UCA6-7](#) [DMN16M9UCA6-7](#) [STF5N65M6](#) [STU5N65M6](#) [C3M0021120D](#) [DMN13M9UCA6-7](#)
[BSS340NWH6327XTSA1](#) [MCM3400A-TP](#) [DMTH10H4M6SPS-13](#) [IPS60R1K0PFD7SAKMA1](#) [IPS60R360PFD7SAKMA1](#)
[IPS60R600PFD7SAKMA1](#) [IPS60R210PFD7SAKMA1](#) [DMN2990UFB-7B](#)