



2SC5569

NPN SILICON TRANSISTOR

DC/DC CONVERTER APPLICATIONS

FEATURES

- *High current capacitance.
- *Low collector-to-emitter saturation voltage.
- *High-speed switching.
- *High allowable power dissipation.
- *Complementary to 2SA2016.

APPLICATIONS

- *Relay drivers, lamp drivers, motor drivers, strobes

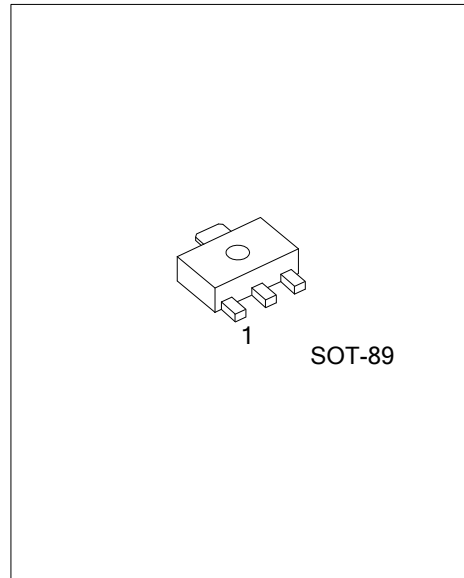

ORDERING INFORMATION

Ordering Number		Package	Pin Assignment			Packing
Lead Free	Halogen Free		1	2	3	
2SC5569L-AB3-R	2SC5569G-AB3-R	SOT-89	B	C	E	Tape Reel

Note: Pin assignment: B: Base C: Collector E: Emitter

<p>2SC5569G-AB3-R</p> <p>(1) Packing Type (2) Package Type (3) Green Package</p>	<p>(1) R: Tape Reel (2) AB3: SOT-89 (3) G: Halogen Free and Lead Free, L: Lead Free</p>
--	---

MARKING

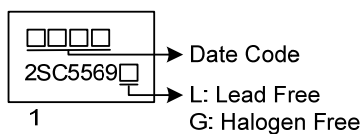

■ ABSOLUTE MAXIMUM RATINGS ($T_A=25^\circ\text{C}$, unless otherwise specified)

PARAMETER	SYMBOL	VALUE	UNIT
Collector-Base Voltage	V_{CBO}	80	V
Collector-Emitter Voltage	V_{CEO}	50	V
Emitter-Base Voltage	V_{EBO}	6	V
Collector Current	I_c	7	A
Collector Current (Pulse)	I_{cp}	10	A
Base Current	I_B	1.2	A
Collector Dissipation (Note 2)	P_C	1.3	W
Collector Dissipation ($T_C=25^\circ\text{C}$)		3.5	W
Junction Temperature	T_J	+150	$^\circ\text{C}$
Storage Temperature	T_{STG}	-55 ~ +150	$^\circ\text{C}$

Notes: 1. Absolute maximum ratings are those values beyond which the device could be permanently damaged.

Absolute maximum ratings are stress ratings only and functional device operation is not implied.

2. Mounted on ceramic board (250mm × 0.8mm)

■ ELECTRICAL CHARACTERISTICS ($T_A=25^\circ\text{C}$, unless otherwise specified)

PARAMETER	SYMBOL	TEST CONDITIONS	MIN	TYP	MAX	UNIT
Collector to Base Breakdown Voltage	$V_{(BR)CBO}$	$I_c=10\mu\text{A}, I_E=0$	80			V
Collector to Emitter Breakdown Voltage	$V_{(BR)CEO}$	$I_c=1\text{mA}, R_{BE}=\infty$	50			V
Emitter to Base Breakdown Voltage	$V_{(BR)EBO}$	$I_E=10\mu\text{A}, I_C=0$	6			V
Collector Cut-Off Current	I_{CBO}	$V_{CB}=40\text{V}, I_E=0$			0.1	μA
Emitter Cut-Off Current	I_{EBO}	$V_{EB}=4\text{V}, I_C=0$			0.1	μA
DC Current Gain	h_{FE}	$V_{CE}=2\text{V}, I_C=500\text{mA}$	200		560	
Collector to Emitter Saturation Voltage	$V_{CE(SAT)}$	$I_c=3.5\text{A}, I_B=175\text{mA}$		160	240	mV
		$I_c=2\text{A}, I_B=40\text{mA}$		110	170	mV
Base to Emitter Saturation Voltage	$V_{BE(SAT)}$	$I_c=2\text{A}, I_B=40\text{mA}$		0.83	1.2	V
Gain Bandwidth Product	f_T	$V_{CE}=10\text{V}, I_C=500\text{mA}$		330		MHz
Output Capacitance	C_{OB}	$V_{CB}=10\text{V}, f=1\text{MHz}$		28		pF
Turn-On Time	T_{ON}	See specified Test Circuit		30		ns
Storage Time	T_{STG}	See specified Test Circuit		420		ns
Fall Time	T_F	See specified Test Circuit		25		ns

■ SWITCHING TIME TEST CIRCUIT

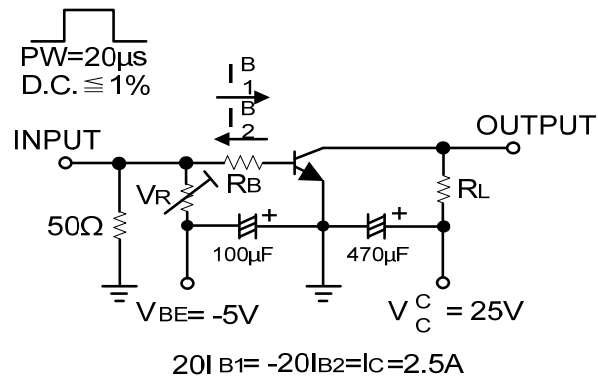

TYPICAL CHARACTERISTICS

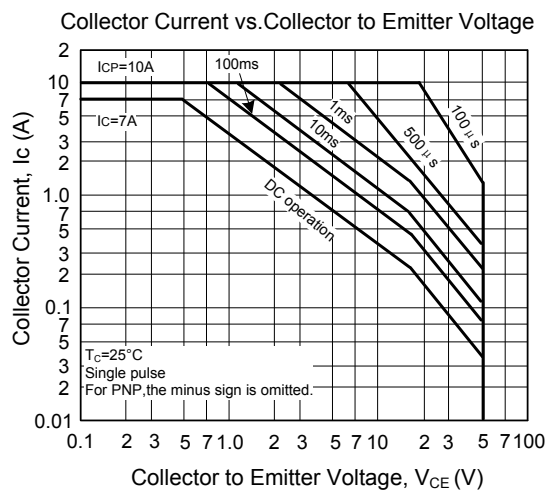
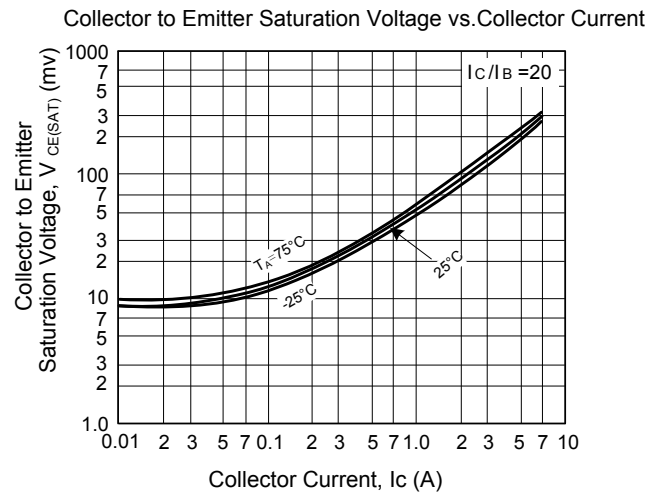
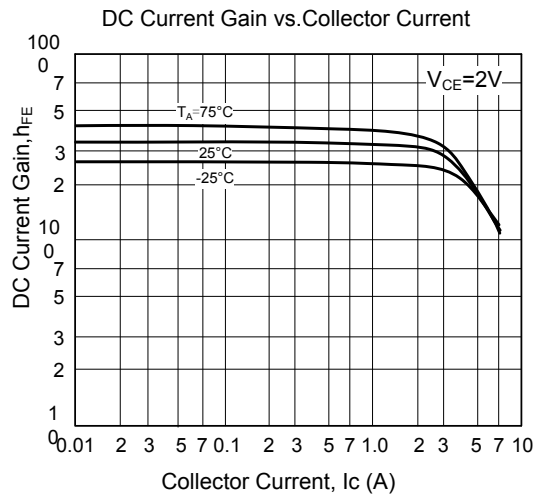
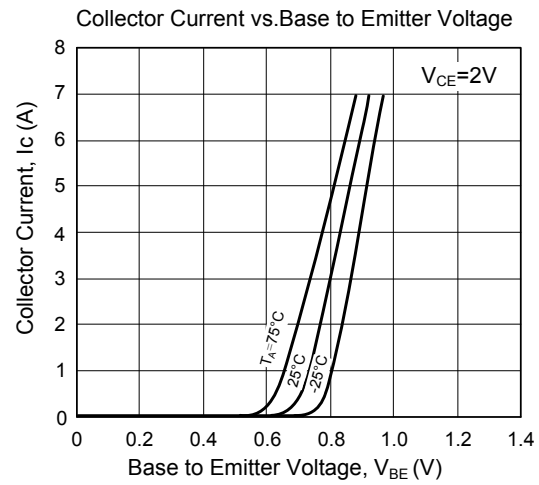
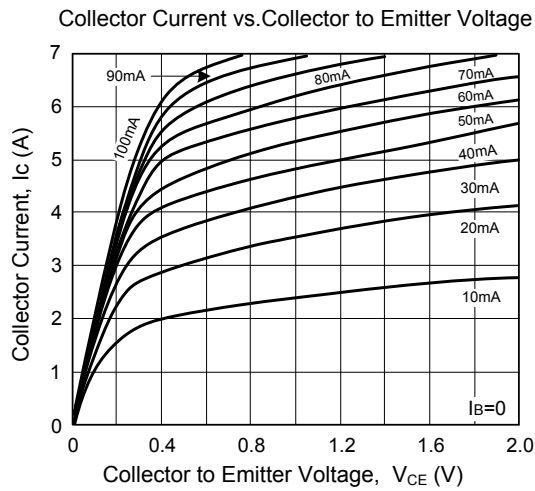

TYPICAL CHARACTERISTICS (Cont.)

Collector to Emitter Saturation Voltage vs. Collector Current

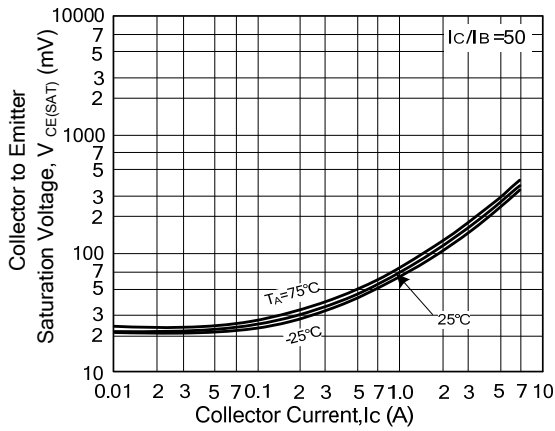

Collector to Emitter Saturation Voltage vs. Collector Current

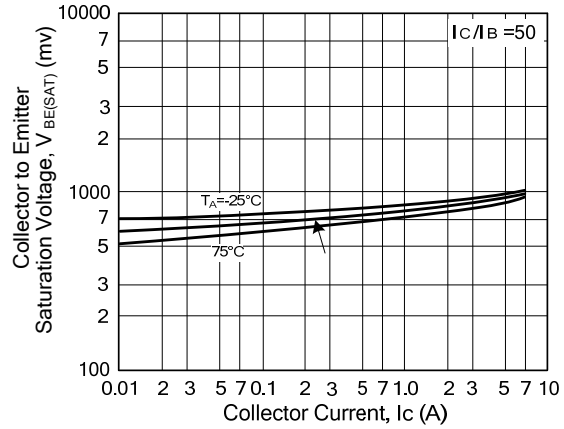

Output Capacitance vs. Collector to Base Voltage

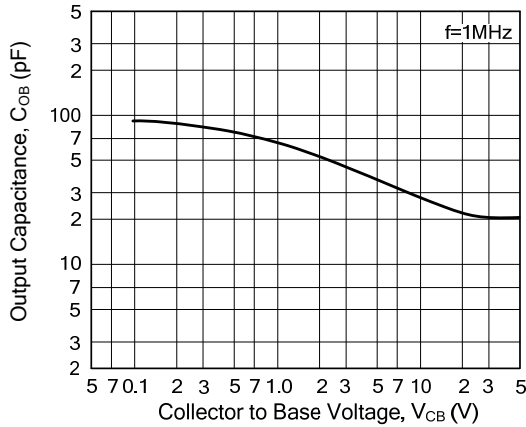

Gain Bandwidth Product vs. Collector Current

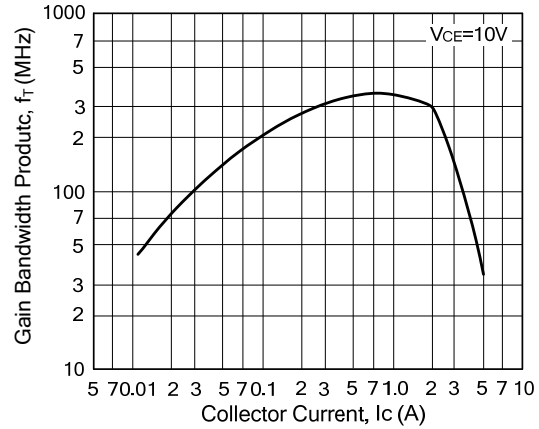

Collector Dissipation vs. Case Temperature

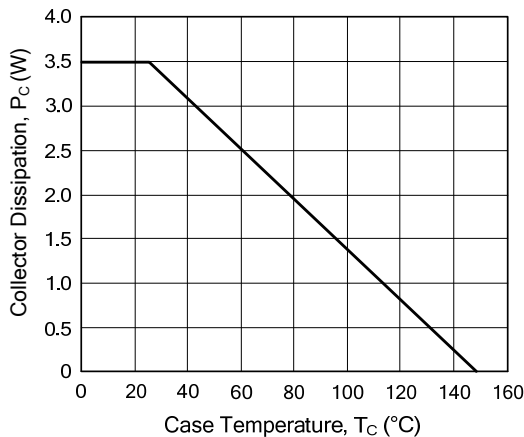

Collector Dissipation vs. Ambient Temperature

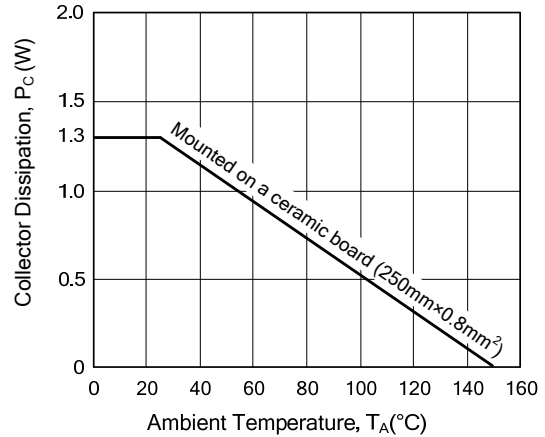

UTC assumes no responsibility for equipment failures that result from using products at values that exceed, even momentarily, rated values (such as maximum ratings, operating condition ranges, or other parameters) listed in products specifications of any and all UTC products described or contained herein. UTC products are not designed for use in life support appliances, devices or systems where malfunction of these products can be reasonably expected to result in personal injury. Reproduction in whole or in part is prohibited without the prior written consent of the copyright owner. UTC reserves the right to make changes to information published in this document, including without limitation specifications and product descriptions, at any time and without notice. This document supersedes and replaces all information supplied prior to the publication hereof.

X-ON Electronics

Largest Supplier of Electrical and Electronic Components

Click to view similar products for [Bipolar Transistors - BJT category](#):

Click to view products by [Unisonic manufacturer](#):

Other Similar products are found below :

[619691C](#) [MCH4017-TL-H](#) [MMBT-2369-TR](#) [BC546/116](#) [BC557/116](#) [BSW67A](#) [NJVMJD148T4G](#) [NTE123AP-10](#) [NTE153MCP](#) [NTE16](#)
[NTE195A](#) [NTE92](#) [2N4401-A](#) [2N6728](#) [2SA1419T-TD-H](#) [2SA2126-E](#) [2SB1204S-TL-E](#) [2SC2712S-GR,LF](#) [SP000011176](#) [2N2907A](#) [2N3904-](#)
[NS](#) [2N5769](#) [2SC2412KT146S](#) [CPH6501-TL-E](#) [MCH4021-TL-E](#) [MJE340](#) [Jantx2N5416](#) [US6T6TR](#) [NJL0281DG](#) [732314D](#) [CPH3121-TL-E](#)
[CPH6021-TL-H](#) [873787E](#) [IMZ2AT108](#) [MMST8098T146](#) [UMX21NTR](#) [MCH6102-TL-E](#) [NJL0302DG](#) [30A02MH-TL-E](#) [NTE13](#) [NTE26](#)
[NTE282](#) [NTE323](#) [NTE350](#) [NTE81](#) [STX83003-AP](#) [JANTX2N2920L](#) [JANSR2N2222AUB](#) [CMLT3946EG TR](#) [2SA1371D-AE](#)