



# 2SD1804

## NPN SILICON TRANSISTOR

### HIGH CURRENT SWITCHING APPLICATIONS

■ FEATURES

- \* Low collector-to-emitter saturation voltage
- \* High current and high  $f_T$
- \* Excellent linearity of  $h_{FE}$ .
- \* Fast switching time
- \* Small and slim package making it easy to make UTC 2SD1804 applied sets smaller.

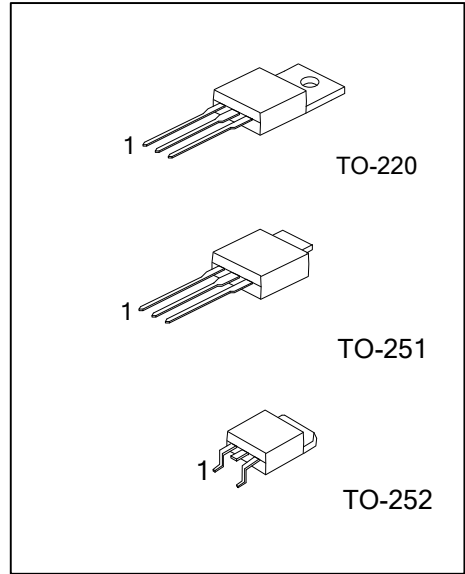

■ ORDERING INFORMATION

Ordering Number		Package	Pin Assignment			Packing
Lead Free	Halogen Free		1	2	3	
2SD1804L-x-TA3-T	2SD1804G-x-TA3-T	TO-220	B	C	E	Tube
2SD1804L-x-TM3-T	2SD1804G-x-TM3-T	TO-251	B	C	E	Tube
2SD1804L-x-TN3-R	2SD1804G-x-TN3-R	TO-252	B	C	E	Tape Reel

Note: Pin Assignment: B: Base C: Collector E: Emitter

<p>2SD1804L-x-TA3-T</p>	<p>(1) Packing Type (2) Package Type (3) Rank (4) Green Package</p>	<p>(1) R: Tape Reel, T: Tube (2) TA3: TO-220, TM3: TO-251, TN3: TO-252 (3) x: refer to Classification of <math>h_{FE1}</math> (4) L: Lead Free, G: Halogen Free and Lead Free</p>
-------------------------	---	---

■ MARKING

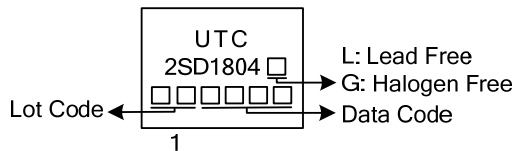

■ ABSOLUTE MAXIMUM RATING ( $T_A=25^\circ\text{C}$ , unless otherwise specified)

PARAMETER		SYMBOL	RATINGS	UNIT
Collector-Base Voltage		$V_{CBO}$	60	V
Collector-Emitter Voltage		$V_{CEO}$	50	V
Emitter-Base Voltage		$V_{EBO}$	6	V
Collector Current		$I_C$	8	A
Collector Current(PULSE)		$I_{C(PULSE)}$	12	A
Collector Dissipation	$T_A=25^\circ\text{C}$	TO-220	2	W
		TO-251/TO-252	1	
	$T_C=25^\circ\text{C}$	TO-220	65	W
		TO-251/TO-252	20	
Junction Temperature		$T_J$	+150	$^\circ\text{C}$
Storage Temperature		$T_{STG}$	-55~+150	$^\circ\text{C}$

Note Absolute maximum ratings are those values beyond which the device could be permanently damaged.

Absolute maximum ratings are stress ratings only and functional device operation is not implied.

■ ELECTRICAL CHARACTERISTICS ( $T_A=25^\circ\text{C}$ , unless otherwise specified)

PARAMETER	SYMBOL	TEST CONDITIONS	MIN	TYP	MAX	UNIT
Collector-Base Breakdown Voltage	$BV_{CBO}$	$I_C=10\mu\text{A}, I_E=0$	60			V
Collector-Emitter Breakdown Voltage	$BV_{CEO}$	$I_C=1\text{mA}, R_{BE}=\infty$	50			V
Emitter-Base Breakdown Voltage	$BV_{EBO}$	$I_E=10\mu\text{A}, I_C=0$	6			V
Collector Cutoff Current	$I_{CBO}$	$V_{CB}=40\text{V}, I_E=0$			1	$\mu\text{A}$
Emitter Cutoff Current	$I_{EBO}$	$V_{EB}=4\text{V}, I_C=0$			1	$\mu\text{A}$
DC Current Gain	$h_{FE1}$	$V_{CE}=2\text{V}, I_C=0.5\text{A}$	70		400	
	$h_{FE2}$	$V_{CE}=2\text{V}, I_C=6\text{A}$	35			
Gain-Bandwidth Product	$f_T$	$V_{CE}=5\text{V}, I_C=1\text{A}$		180		MHz
Output Capacitance	$C_{ob}$	$V_{CE}=10\text{V}, f=1\text{MHz}$		65		pF
Collector-Emitter Saturation Voltage	$V_{CE(SAT)}$	$I_C=4\text{A}, I_B=0.2\text{A}$		200	400	mV
Base-Emitter Saturation Voltage	$V_{BE(SAT)}$	$I_C=4\text{A}, I_B=0.2\text{A}$		0.95	1.3	V
Storage Time	$t_{STG}$	See test circuit		500		ns
Fall Time	$t_F$	See test circuit		20		ns

■ CLASSIFICATION OF  $h_{FE1}$

RANK	Q	R	S	T
RANGE	70-140	100-200	140-280	200-400

### ■ TEST CIRCUIT

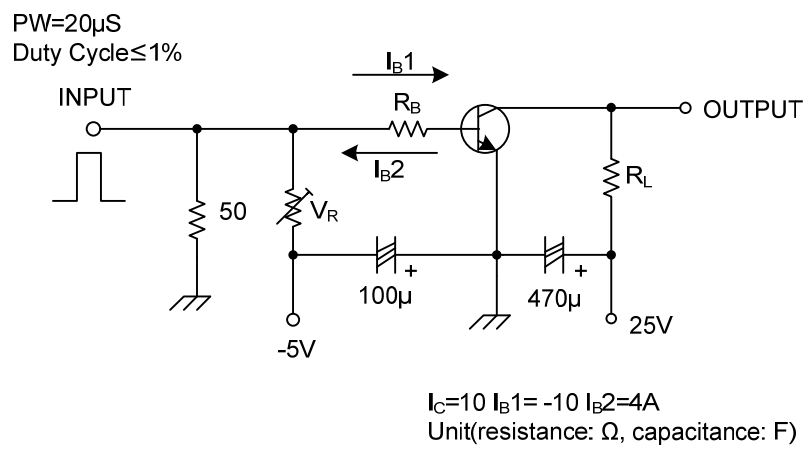

## TYPICAL CHARACTERISTICS

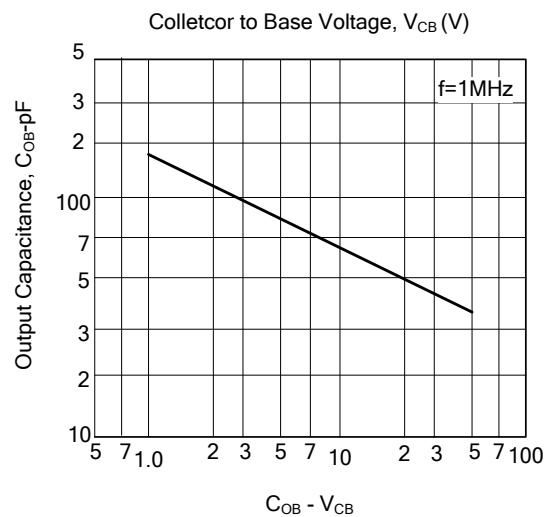
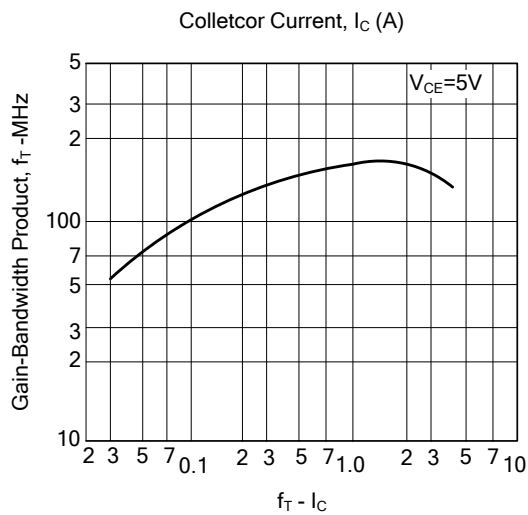
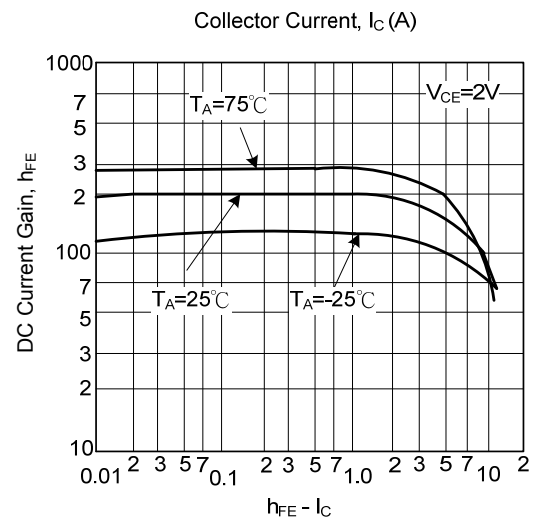
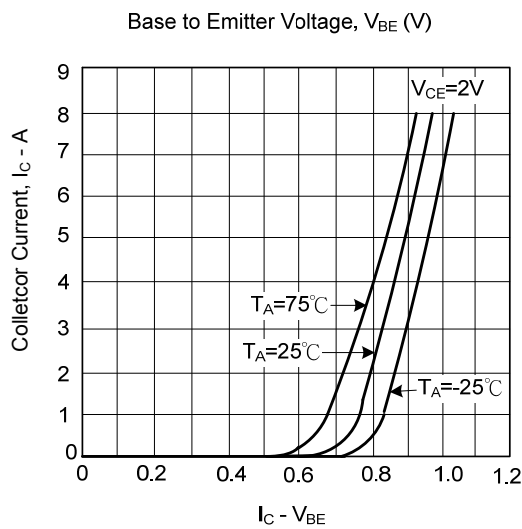
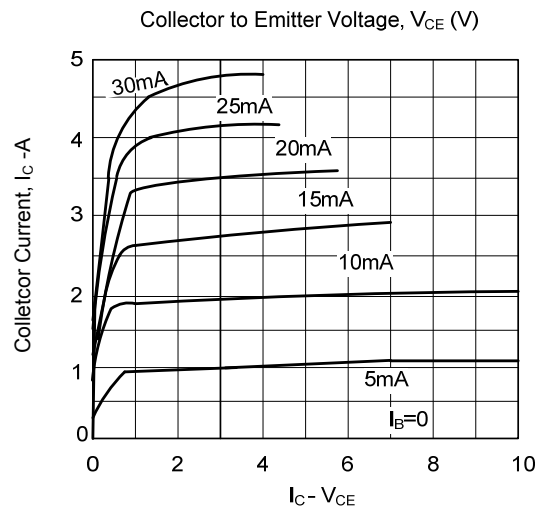
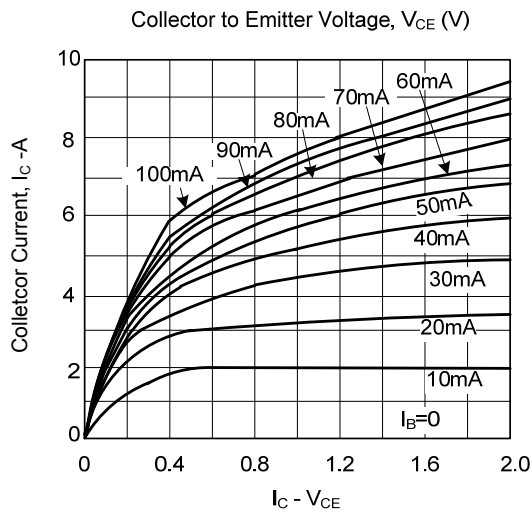

## TYPICAL CHARACTERISTICS(Cont.)

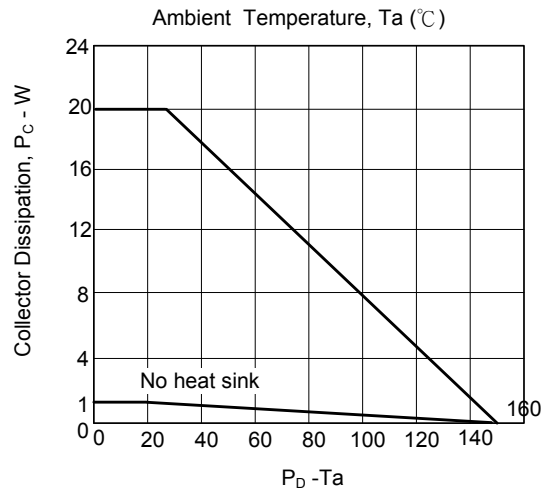
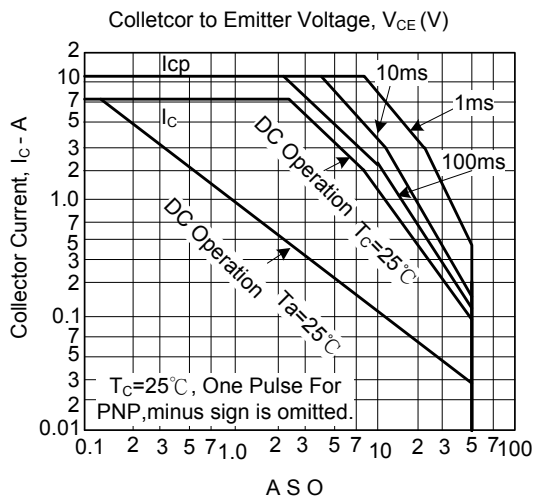
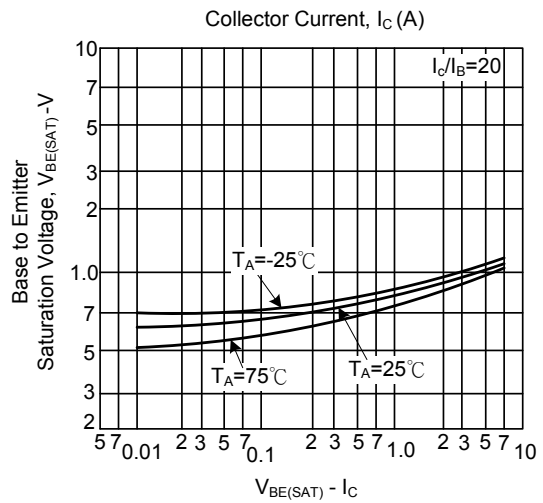
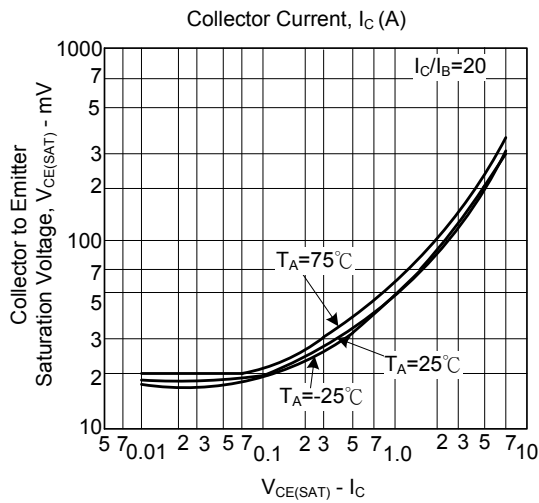

UTC assumes no responsibility for equipment failures that result from using products at values that exceed, even momentarily, rated values (such as maximum ratings, operating condition ranges, or other parameters) listed in products specifications of any and all UTC products described or contained herein. UTC products are not designed for use in life support appliances, devices or systems where malfunction of these products can be reasonably expected to result in personal injury. Reproduction in whole or in part is prohibited without the prior written consent of the copyright owner. The information presented in this document does not form part of any quotation or contract, is believed to be accurate and reliable and may be changed without notice.

## X-ON Electronics

Largest Supplier of Electrical and Electronic Components

*Click to view similar products for [Bipolar Transistors - BJT category](#):*

*Click to view products by [Unisonic manufacturer](#):*

Other Similar products are found below :

[619691C](#) [MCH4017-TL-H](#) [MMBT-2369-TR](#) [BC546/116](#) [BC557/116](#) [BSW67A](#) [NJVMJD148T4G](#) [NTE123AP-10](#) [NTE153MCP](#) [NTE16](#)  
[NTE195A](#) [NTE92](#) [C4460](#) [2N4401-A](#) [2N6728](#) [2SA1419T-TD-H](#) [2SA2126-E](#) [2SB1204S-TL-E](#) [2SC2712S-GR,LF](#) [2SC5488A-TL-H](#)  
[2SD2150T100R](#) [SP000011176](#) [2N2907A](#) [2N3904-NS](#) [2N5769](#) [2SC2412KT146S](#) [2SD1816S-TL-E](#) [CPH6501-TL-E](#) [MCH4021-TL-E](#)  
[MJE340](#) [US6T6TR](#) [NJL0281DG](#) [732314D](#) [CPH3121-TL-E](#) [CPH6021-TL-H](#) [873787E](#) [IMZ2AT108](#) [UMX21NTR](#) [MCH6102-TL-E](#)  
[NJL0302DG](#) [2N3583](#) [30A02MH-TL-E](#) [NSV40301MZ4T1G](#) [NTE13](#) [NTE26](#) [NTE282](#) [NTE323](#) [NTE350](#) [NTE81](#) [STX83003-AP](#)