



# 4N65-Q

Power MOSFET

## 4.0A, 650V N-CHANNEL POWER MOSFET

### DESCRIPTION

The UTC **4N65-Q** is a high voltage power MOSFET designed to have better characteristics, such as fast switching time, low gate charge, low on-state resistance and have a high rugged avalanche characteristic. This power MOSFET is usually used in high speed switching applications including power supplies, PWM motor controls, high efficient AC to DC converters and bridge circuits.

### FEATURES

- \*  $R_{DS(ON)} \leq 3.1 \Omega @ V_{GS}=10V, I_D=2.2A$
- \* Fast Switching Capability
- \* Avalanche Energy Specified
- \* Improved dv/dt Capability, High Ruggedness

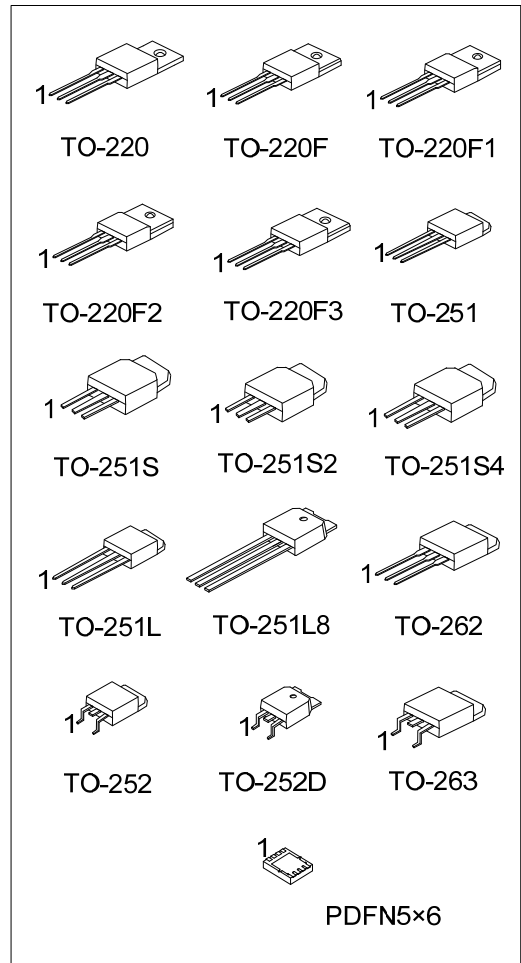

### SYMBOL

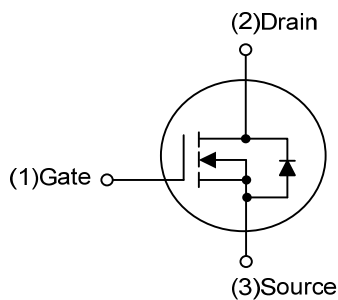

TO-220/TO-220F/TO-220F1  
 TO-220F2/TO-220F3/TO-251  
 TO-251S/TO-251L/TO-251L8  
 TO-251S2/TO-251S4/TO-252  
 TO-252D/TO-262/TO-263

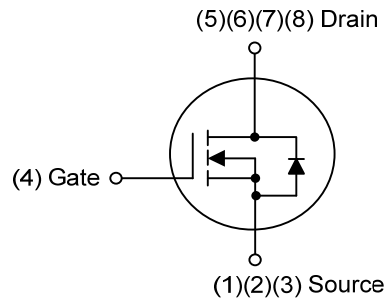

PDFN5x6

## ORDERING INFORMATION

Ordering Number		Package	Pin Assignment								Packing
Lead Free	Halogen Free		1	2	3	4	5	6	7	8	
4N65L-TA3-T	4N65G-TA3-T	TO-220	G	D	S	-	-	-	-	-	Tube
4N65L-TF1-T	4N65G-TF1-T	TO-220F1	G	D	S	-	-	-	-	-	Tube
4N65L-TF2-T	4N65G-TF2-T	TO-220F2	G	D	S	-	-	-	-	-	Tube
4N65L-TF3T-T	4N65G-TF3T-T	TO-220F3	G	D	S	-	-	-	-	-	Tube
4N65L-TF3-T	4N65G-TF3-T	TO-220F	G	D	S	-	-	-	-	-	Tube
4N65L-TM3-T	4N65G-TM3-T	TO-251	G	D	S	-	-	-	-	-	Tube
4N65L-TMA-T	4N65G-TMA-T	TO-251L	G	D	S	-	-	-	-	-	Tube
4N65L-TMA8-T	4N65G-TMA8-T	TO-251L8	G	D	S	-	-	-	-	-	Tube
4N65L-TMS-T	4N65G-TMS-T	TO-251S	G	D	S	-	-	-	-	-	Tube
4N65L-TMS2-T	4N65G-TMS2-T	TO-251S2	G	D	S	-	-	-	-	-	Tube
4N65L-TMS4-T	4N65G-TMS4-T	TO-251S4	G	D	S	-	-	-	-	-	Tube
4N65L-TN3-R	4N65G-TN3-R	TO-252	G	D	S	-	-	-	-	-	Tape Reel
4N65L-TND-R	4N65G-TND-R	TO-252D	G	D	S	-	-	-	-	-	Tape Reel
4N65L-T2Q-T	4N65G-T2Q-T	TO-262	G	D	S	-	-	-	-	-	Tube
4N65L-TQ2-R	4N65G-TQ2-R	TO-263	G	D	S	-	-	-	-	-	Tape Reel
4N65L-TQ2-T	4N65G-TQ2-T	TO-263	G	D	S	-	-	-	-	-	Tube
4N65L-P5060-R	4N65G-P5060-R	PDFN5×6	S	S	S	G	D	D	D	D	Tape Reel

Note: Pin Assignment: G: Gate D: Drain S: Source

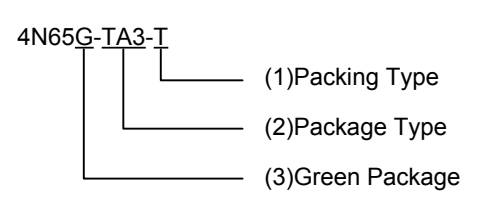
<p>4N65G-TA3-T</p>  <p>(1) Packing Type (2) Package Type (3) Green Package</p>	<p>(1) T: Tube, R: Tape Reel (2) TA3: TO-220, TF1: TO-220F1, TF2: TO-220F2 TF3: TO-220F, TF3T: TO-220F3, TM3: TO-251, TMA: TO-251L, TMA8: TO-251L8, TMS: TO-251S, TMS2: TO-251S2, TN3: TO-252, TMS4: TO-251S4, TND: TO-252D, T2Q: TO-262, TQ2: TO-263, P5060: PDFN5×6 (3) G: Halogen Free and Lead Free, L: Lead Free</p>
---------------------------------------------------------------------------------------------------------------------------------------------------------------------------	-------------------------------------------------------------------------------------------------------------------------------------------------------------------------------------------------------------------------------------------------------------------------------------------------------------------------------------------------------

## MARKING

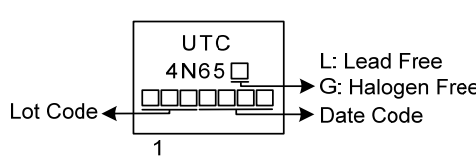
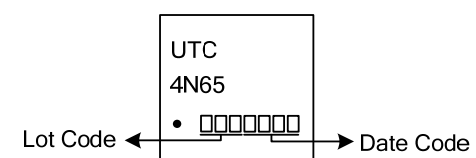
PACKAGE		MARKING
<p>TO-220 TO-220F TO-220F1 TO-220F2 TO-220F3 TO-251 TO-251L TO-251L8</p>	<p>TO-251S TO-251S2 TO-251S4 TO-252 TO-252D TO-262 TO-263</p>	 <p>L: Lead Free G: Halogen Free</p>
<p>PDFN5×6</p>		

■ ABSOLUTE MAXIMUM RATINGS ( $T_C = 25^\circ\text{C}$ , unless otherwise specified)

PARAMETER		SYMBOL	RATINGS	UNIT
Drain-Source Voltage		$V_{DSS}$	650	V
Gate-Source Voltage		$V_{GSS}$	$\pm 30$	V
Avalanche Current (Note2)		$I_{AR}$	4.4	A
Drain Current	Continuous	$I_D$	4.0	A
	Pulsed (Note2)	$I_{DM}$	16	A
Avalanche Energy	Single Pulsed (Note3)	$E_{AS}$	60	mJ
	Repetitive (Note2)	$E_{AR}$	10.6	mJ
Peak Diode Recovery dv/dt (Note4)		dv/dt	4.5	V/ns
Power Dissipation	TO-220/TO-262/TO-263	$P_D$	106	W
	TO-220F/TO-220F1		36	W
	TO-220F3			
	TO-220F2		38	W
	TO-251/TO-251L TO-251L8/TO-251S TO-251S2/TO-251S4 TO-252/TO-252D		50	W
	PDFN5×6		30	W
Junction Temperature		$T_J$	+150	$^\circ\text{C}$
Operating Temperature		$T_{OPR}$	-55 ~ +150	$^\circ\text{C}$
Storage Temperature		$T_{STG}$	-55 ~ +150	$^\circ\text{C}$

Notes: 1. Absolute maximum ratings are those values beyond which the device could be permanently damaged.

Absolute maximum ratings are stress ratings only and functional device operation is not implied.

2. Repetitive Rating: Pulse width limited by maximum junction temperature.

3.  $L = 30\text{mH}$ ,  $I_{AS} = 2.1\text{A}$ ,  $V_{DD} = 50\text{V}$ ,  $R_G = 25\ \Omega$ , Starting  $T_J = 25^\circ\text{C}$

4.  $I_{SD} \leq 4.4\text{A}$ ,  $di/dt \leq 200\text{A}/\mu\text{s}$ ,  $V_{DD} \leq BV_{DSS}$ , Starting  $T_J = 25^\circ\text{C}$

■ THERMAL DATA

PARAMETER	PACKAGE	SYMBOL	RATINGS	UNIT
Junction to Ambient	TO-220/TO-262/TO-263 TO-220F/TO-220F1 TO-220F2/TO-220F3	$\theta_{JA}$	62.5	$^\circ\text{C}/\text{W}$
	TO-251/TO-251L TO-251L8/TO-251S TO-251S2/TO-251S4 TO-252/TO-252D		83	$^\circ\text{C}/\text{W}$
	PDFN5×6		75 (Note)	$^\circ\text{C}/\text{W}$
Junction to Case	TO-220/TO-262/TO-263	$\theta_{JC}$	1.18	$^\circ\text{C}/\text{W}$
	TO-220F/TO-220F1		3.47	$^\circ\text{C}/\text{W}$
	TP-220F3			
	TO-220F2		3.28	$^\circ\text{C}/\text{W}$
	TO-251/TO-251L TO-251L8/TO-251S TO-251S2/TO-251S4 TO-252/TO-252D		2.5	$^\circ\text{C}/\text{W}$
	PDFN5×6		4.17 (Note)	$^\circ\text{C}/\text{W}$

Note: The data tested by surface mounted on a 1 inch<sup>2</sup> FR-4 board with 2OZ copper.

■ ELECTRICAL CHARACTERISTICS (T<sub>C</sub>=25°C, unless otherwise specified)

PARAMETER	SYMBOL	TEST CONDITIONS	MIN	TYP	MAX	UNIT
<b>OFF CHARACTERISTICS</b>						
Drain-Source Breakdown Voltage	BV <sub>DSS</sub>	V <sub>GS</sub> = 0 V, I <sub>D</sub> = 250μA	650			V
Drain-Source Leakage Current	I <sub>DSS</sub>	V <sub>DS</sub> = 650 V, V <sub>GS</sub> = 0 V			10	μA
Gate-Source Leakage Current	Forward	I <sub>GSS</sub>	V <sub>GS</sub> = 30 V, V <sub>DS</sub> = 0 V		100	nA
	Reverse		V <sub>GS</sub> = -30 V, V <sub>DS</sub> = 0 V		-100	nA
Breakdown Voltage Temperature Coefficient	ΔBV <sub>DSS</sub> /ΔT <sub>J</sub>	I <sub>D</sub> =250μA, Referenced to 25°C		0.6		V/°C
<b>ON CHARACTERISTICS</b>						
Gate Threshold Voltage	V <sub>GS(TH)</sub>	V <sub>DS</sub> = V <sub>GS</sub> , I <sub>D</sub> = 250μA	2.0		4.0	V
Static Drain-Source On-State Resistance	R <sub>DS(ON)</sub>	V <sub>GS</sub> = 10 V, I <sub>D</sub> = 2.2A		2.9	3.1	Ω
<b>DYNAMIC CHARACTERISTICS</b>						
Input Capacitance	C <sub>ISS</sub>	V <sub>GS</sub> =V, V <sub>DS</sub> =25V, f=1MHz		470	530	pF
Output Capacitance	C <sub>OSS</sub>			50	70	pF
Reverse Transfer Capacitance	C <sub>RSS</sub>			10	13	pF
<b>SWITCHING CHARACTERISTICS</b>						
Total Gate Charge (Note 1)	Q <sub>G</sub>	V <sub>DS</sub> =520V, I <sub>D</sub> = 4.0A, V <sub>GS</sub> =10V (Note 1, 2)		55	75	nC
Gate-Source Charge	Q <sub>GS</sub>			15	21	nC
Gate-Drain Charge	Q <sub>GD</sub>			18	24	nC
Turn-On Delay Time (Note 1)	t <sub>D(ON)</sub>	V <sub>DS</sub> =325V, I <sub>D</sub> 4.0A, R <sub>G</sub> =25Ω (Note 1, 2)		38	75	ns
Turn-On Rise Time	t <sub>R</sub>			45	85	ns
Turn-Off Delay Time	t <sub>D(OFF)</sub>			90	130	ns
Turn-Off Fall Time	t <sub>F</sub>			35	80	ns
<b>SOURCE- DRAIN DIODE RATINGS AND CHARACTERISTICS</b>						
Maximum Continuous Drain-Source Diode Forward Current	I <sub>S</sub>				4.4	A
Maximum Pulsed Drain-Source Diode Forward Current	I <sub>SM</sub>				17.6	A
Drain-Source Diode Forward Voltage (Note 1)	V <sub>SD</sub>	V <sub>GS</sub> = 0 V, I <sub>S</sub> = 4.4A			1.4	V
Reverse Recovery Time (Note 1)	t <sub>rr</sub>	V <sub>GS</sub> = 0V, I <sub>S</sub> = 4.4A, di/dt = 100 A/μs (Note 1)		250		ns
Reverse Recovery Charge	Q <sub>rr</sub>				1.5	

Note: 1. Pulse Test: Pulse width ≤ 300μs, Duty cycle ≤ 2%.

2. Essentially independent of operating temperature.

■ TEST CIRCUITS AND WAVEFORMS

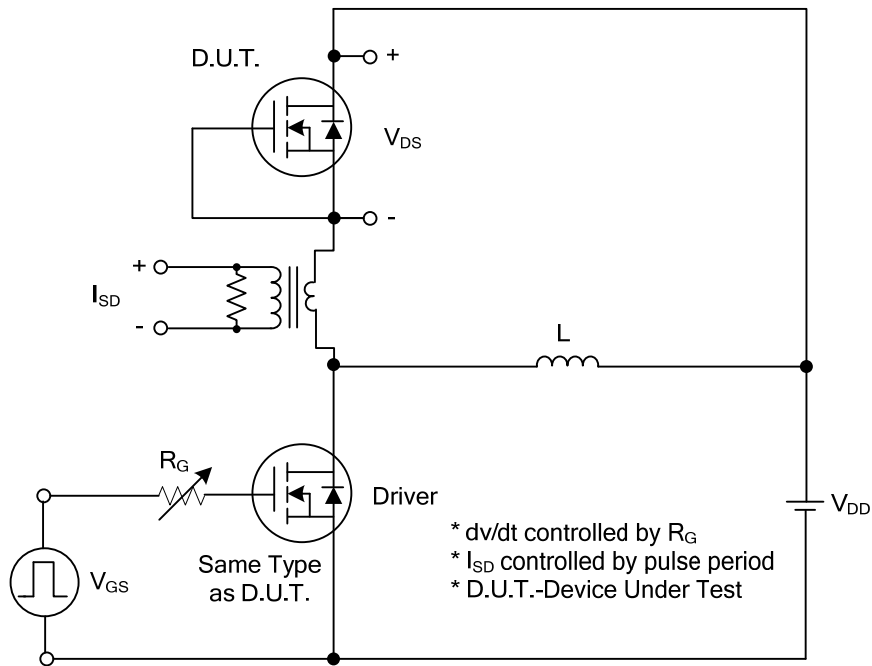

Peak Diode Recovery dv/dt Test Circuit

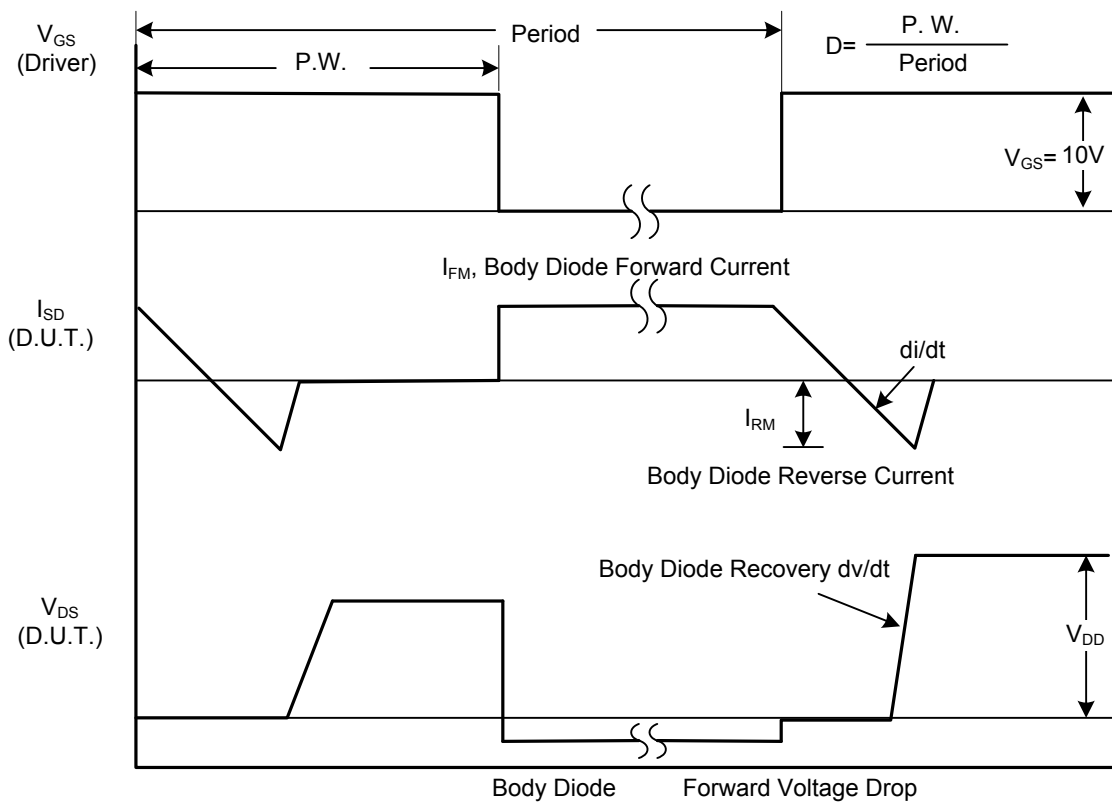

Peak Diode Recovery dv/dt Waveforms

## TEST CIRCUITS AND WAVEFORMS

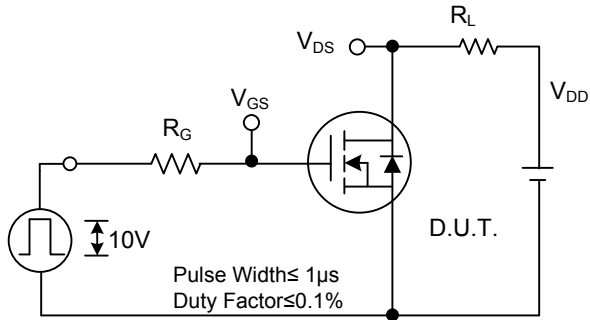

**Switching Test Circuit**

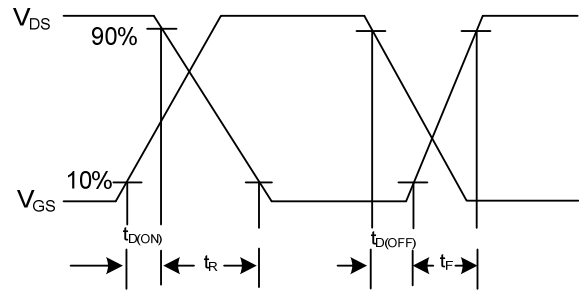

**Switching Waveforms**

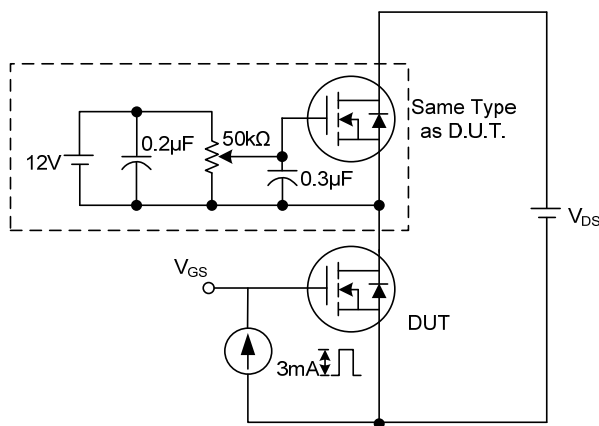

**Gate Charge Test Circuit**

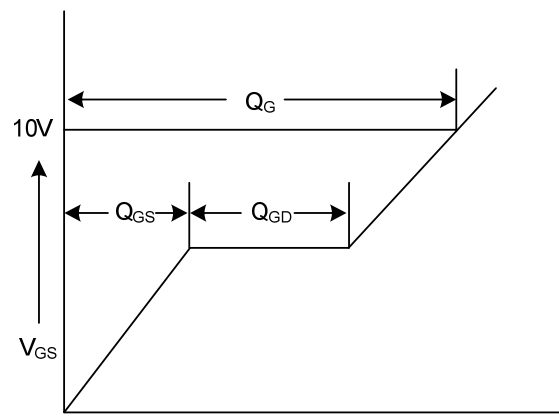

**Gate Charge Waveform**

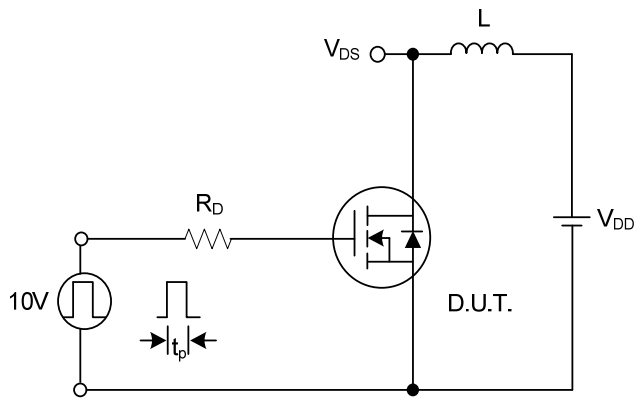

**Unclamped Inductive Switching Test Circuit**

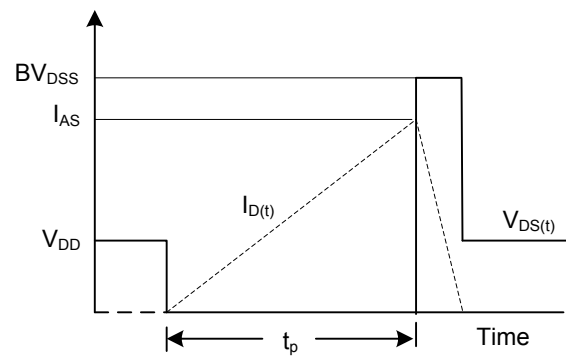

**Unclamped Inductive Switching Waveforms**

## TYPICAL CHARACTERISTICS

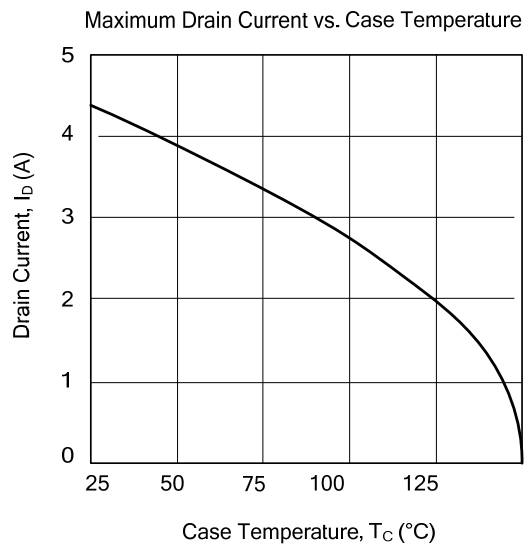
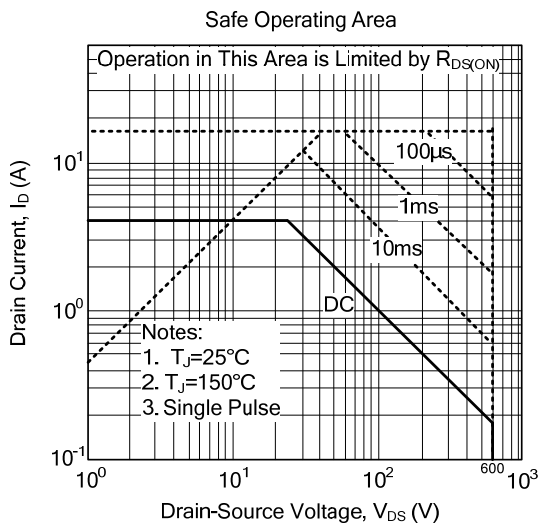
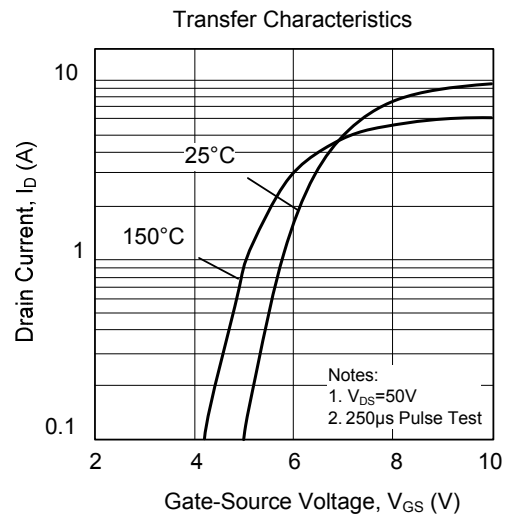
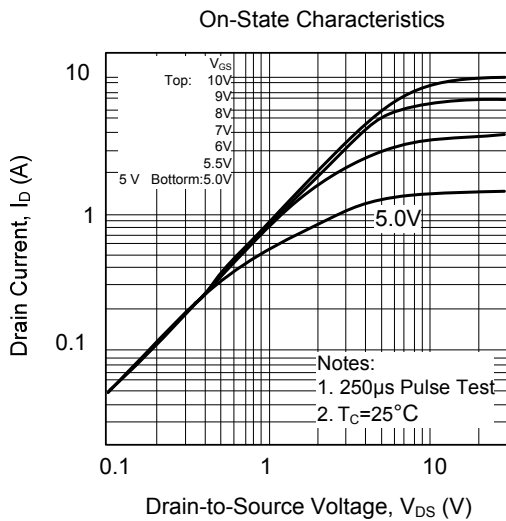
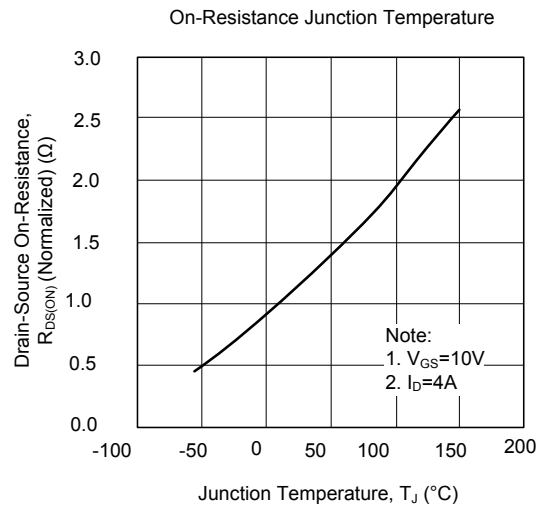
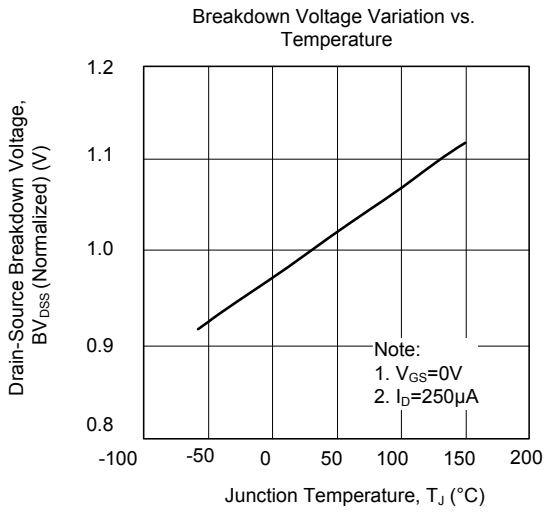

■ TYPICAL CHARACTERISTICS (Cont.)

On-Resistance Variation vs. Drain Current and Gate Voltage

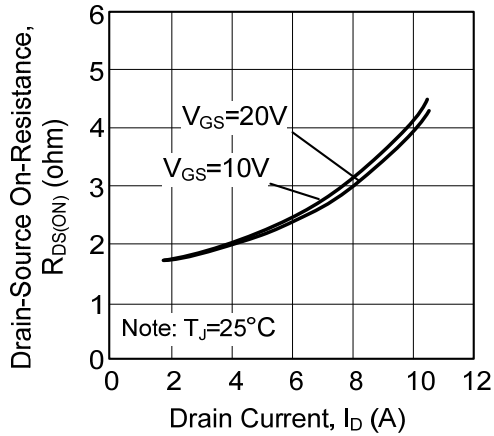

On State Current vs. Allowable Case Temperature

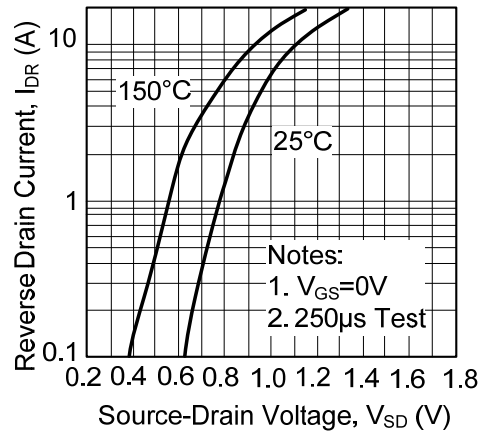

Capacitance Characteristics (Non-Repetitive)

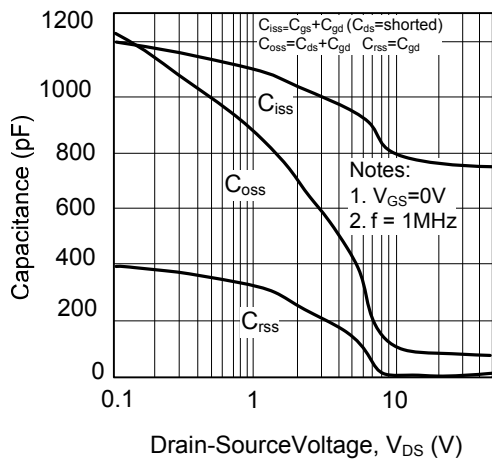

Gate Charge Characteristics

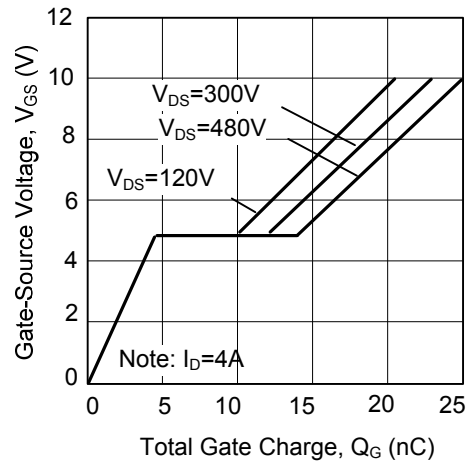

Transient Thermal Response Curve

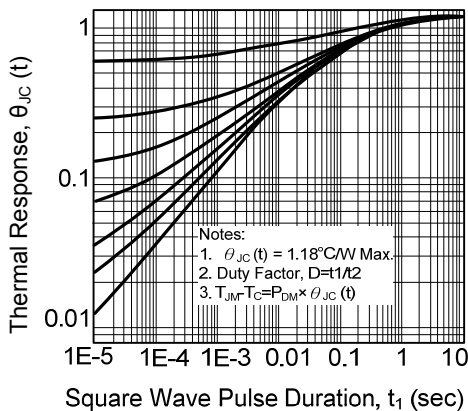

Power Dissipation

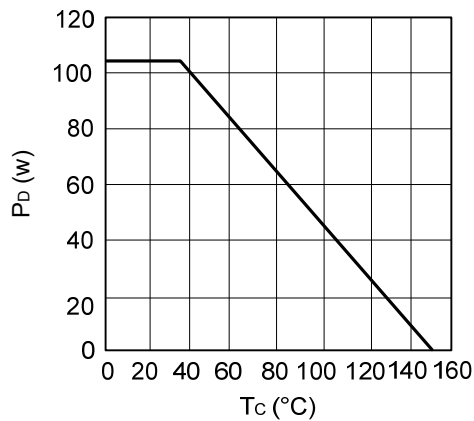



UTC assumes no responsibility for equipment failures that result from using products at values that exceed, even momentarily, rated values (such as maximum ratings, operating condition ranges, or other parameters) listed in products specifications of any and all UTC products described or contained herein. UTC products are not designed for use in life support appliances, devices or systems where malfunction of these products can be reasonably expected to result in personal injury. Reproduction in whole or in part is prohibited without the prior written consent of the copyright owner. UTC reserves the right to make changes to information published in this document, including without limitation specifications and product descriptions, at any time and without notice. This document supersedes and replaces all information supplied prior to the publication hereof.

## X-ON Electronics

Largest Supplier of Electrical and Electronic Components

*Click to view similar products for [MOSFET](#) category:*

*Click to view products by [Unisonic](#) manufacturer:*

Other Similar products are found below :

[IRFD120](#) [JANTX2N5237](#) [BUK455-60A/B](#) [MIC4420CM-TR](#) [VN1206L](#) [NDP4060](#) [SI4482DY](#) [IPS70R2K0CEAKMA1](#) [SQD23N06-31L-GE3](#)  
[TK16J60W,S1VQ\(O](#) [2SK2614\(TE16L1,Q\)](#) [DMN1017UCP3-7](#) [DMN1053UCP4-7](#) [SQJ469EP-T1-GE3](#) [NTE2384](#) [DMC2700UDMQ-7](#)  
[DMN2080UCB4-7](#) [DMN61D9UWQ-13](#) [US6M2GTR](#) [DMN31D5UDJ-7](#) [DMP22D4UFO-7B](#) [DMN1006UCA6-7](#) [DMN16M9UCA6-7](#)  
[STF5N65M6](#) [IRF40H233XTMA1](#) [STU5N65M6](#) [DMN6022SSD-13](#) [DMN13M9UCA6-7](#) [DMTH10H4M6SPS-13](#) [DMN2990UFB-7B](#)  
[IPB80P04P405ATMA2](#) [2N7002W-G](#) [MCAC30N06Y-TP](#) [MCQ7328-TP](#) [BXP7N65D](#) [BXP4N65F](#) [AOL1454G](#) [WMJ80N60C4](#) [BXP2N20L](#)  
[BXP2N65D](#) [BXT1150N10J](#) [BXT1700P06M](#) [TSM60NB380CP](#) [ROG](#) [RQ7L055BGTCR](#) [DMNH15H110SK3-13](#) [SLF10N65ABV2](#)  
[BSO203SP](#) [BSO211P](#) [IPA60R230P6](#) [IPA60R460CE](#)