



4N80

Power MOSFET

4.0A, 800V N-CHANNEL POWER MOSFET

DESCRIPTION

The UTC **4N80** is a N-channel mode power MOSFET using UTC's advanced technology to provide customers planar stripe and DMOS technology. This technology is specialized in allowing a minimum on-state resistance, and superior switching performance. It also can withstand high energy pulse in the avalanche and commutation mode.

The UTC **4N80** is universally applied in high efficiency switch mode power supply.

FEATURES

- * $R_{DS(on)}=3.0\Omega @V_{GS}=10V$
- * High switching speed
- * Improved dv/dt capability
- * 100% avalanche tested

SYMBOL

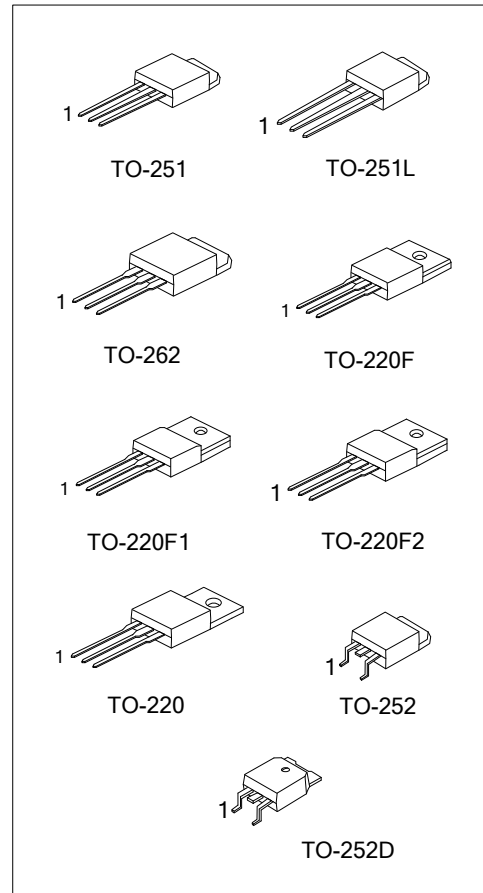
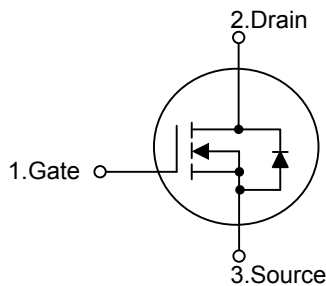

ORDERING INFORMATION

Ordering Number		Package	Pin Assignment			Packing
Lead Free	Halogen Free		1	2	3	
4N80L-TA3-T	4N80G-TA3-T	TO-220	G	D	S	Tube
4N80L-TF1-T	4N80G-TF1-T	TO-220F1	G	D	S	Tube
4N80L-TF2-T	4N80G-TF2-T	TO-220F2	G	D	S	Tube
4N80L-TF3-T	4N80G-TF3-T	TO-220F	G	D	S	Tube
4N80L-TM3-T	4N80G-TM3-T	TO-251	G	D	S	Tube
4N80L-TMA-T	4N80G-TMA-T	TO-251L	G	D	S	Tube
4N80L-TN3-R	4N80G-TN3-R	TO-252	G	D	S	Tape Reel
4N80L-TND-R	4N80G-TND-R	TO-252D	G	D	S	Tape Reel
4N80L-T2Q-T	4N80G-T2Q-T	TO-262	G	D	S	Tube

Note: Pin Assignment: G: Gate D: Drain S: Source

<p>4N80L-TA3-T</p> <p>(1) Packing Type (2) Package Type (3) Green Package</p>	<p>(1) T: Tube, R: Tape Reel (2) TA3: TO-220, TF3: TO-220F, TF1: TO-220F1 TF2: TO-220F2, TM3: TO-251, TMA: TO-251L TN3: TO-252, TND: TO-252D, T2Q: TO-262 (3) L: Lead Free, G: Halogen Free and Lead Free</p>
---	---

MARKING

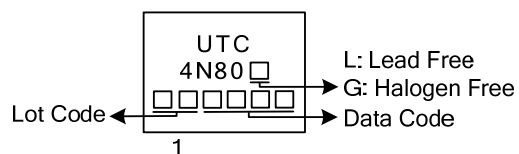

■ ABSOLUTE MAXIMUM RATINGS ($T_c=25^\circ\text{C}$, unless otherwise specified)

PARAMETER		SYMBOL	RATINGS	UNIT
Drain-Source Voltage		V_{DSS}	800	V
Gate-Source Voltage		V_{GSS}	± 30	V
Drain Current	Continuous	I_D	4.0	A
	Pulsed (Note 2)	I_{DM}	16	A
Avalanche Energy	Single Pulsed (Note 3)	E_{AS}	460	mJ
	Repetitive (Note 2)	E_{AR}	13	mJ
Peak Diode Recovery dv/dt (Note 4)		dv/dt	4.0	V/ns
Power Dissipation	TO-220/TO-262	P_D	106	W
	TO-220F/TO-220F1		36	W
	TO-220F2		38	W
	TO-251/TO-251L		50	W
	TO-252/TO-252D			
Junction Temperature		T_J	+150	$^\circ\text{C}$
Storage Temperature		T_{STG}	-55 ~ +150	$^\circ\text{C}$

Notes: 1. Absolute maximum ratings are those values beyond which the device could be permanently damaged.

Absolute maximum ratings are stress ratings only and functional device operation is not implied.

2. Repetitive Rating: Pulse width limited by maximum junction temperature

3. $L=57\text{mH}$, $I_{AS}=4\text{A}$, $V_{DD}=50\text{V}$, $R_G=25\Omega$, Starting $T_J=25^\circ\text{C}$

4. $I_{SD}\leq 4\text{A}$, $di/dt\leq 200\text{A}/\mu\text{s}$, $V_{DD}\leq BV_{DSS}$, Starting $T_J=25^\circ\text{C}$

■ THERMAL DATA

PARAMETER		SYMBOL	RATINGS	UNIT
Junction to Ambient	TO-220/TO-220F TO-220F1/TO-220F2 TO-262	θ_{JA}	62.5	$^\circ\text{C}/\text{W}$
	TO-251/TO-251L TO-252/TO-252D		110	$^\circ\text{C}/\text{W}$
Junction to Case	TO-220/TO-262	θ_{JC}	1.18	$^\circ\text{C}/\text{W}$
	TO-220F/TO-220F1		3.47	$^\circ\text{C}/\text{W}$
	TO-220F2		3.28	$^\circ\text{C}/\text{W}$
	TO-251/TO-251L TO-252/TO-252D		2.5	$^\circ\text{C}/\text{W}$

■ ELECTRICAL CHARACTERISTICS (T_C=25°C, unless otherwise specified)

PARAMETER	SYMBOL	TEST CONDITIONS	MIN	TYP	MAX	UNIT
OFF CHARACTERISTICS						
Drain-Source Breakdown Voltage	BV _{DSS}	V _{GS} =0V, I _D =250μA	800			V
Breakdown Voltage Temperature Coefficient	ΔBV _{DSS} /ΔT _J	I _D =250μA, Referenced to 25°C		950		mV/°C
Drain-Source Leakage Current	I _{DSS}	V _{DS} =800V, V _{GS} =0V			10	μA
		V _{DS} =640V, T _C =125°C			100	μA
Gate-Source Leakage Current	Forward	I _{GSS}				
	Reverse					
		V _{DS} =0V, V _{GS} =30V			100	nA
		V _{DS} =0V, V _{GS} =-30V			-100	nA
ON CHARACTERISTICS						
Gate Threshold Voltage	V _{GS(TH)}	V _{DS} =V _{GS} , I _D =250μA	3.0		5.0	V
Drain-Source On-State Resistance	R _{DS(ON)}	V _{GS} =10V, I _D =2A		2.3	3.0	Ω
DYNAMIC PARAMETERS						
Input Capacitance	C _{ISS}	V _{GS} =0V, V _{DS} =25V, f=1.0MHz		680	880	pF
Output Capacitance	C _{OSS}			75	100	pF
Reverse Transfer Capacitance	C _{RSS}			8.6	12	pF
SWITCHING PARAMETERS						
Total Gate Charge (Note 1)	Q _G	V _{DS} =640V, V _{GS} =10V, I _D =4A (Note 1,2)		19	25	nC
Gate-Source Charge	Q _{GS}			4.2		nC
Gate-Drain Charge	Q _{GD}			9.1		nC
Turn-ON Delay Time (Note 1)	t _{D(ON)}	V _{DD} =400V, I _D =4A, R _G =25Ω (Note 1,2)		16	40	ns
Turn-ON Rise Time	t _R			45	100	ns
Turn-OFF Delay Time	t _{D(OFF)}			35	80	ns
Turn-OFF Fall Time	t _F			35	80	ns
SOURCE- DRAIN DIODE RATINGS AND CHARACTERISTICS						
Maximum Body-Diode Continuous Current	I _S				4	A
Maximum Body-Diode Pulsed Current	I _{SM}				16	A
Drain-Source Diode Forward Voltage (Note 1)	V _{SD}	I _S =4A, V _{GS} =0V			1.4	V
Body Diode Reverse Recovery Time (Note 1)	t _{rr}	V _{GS} =0V, I _S =4A, dI _F /dt=100A/μs (Note 1)		575		ns
Body Diode Reverse Recovery Charge	Q _{rr}				3.65	

Notes: 1. Pulse Test: Pulse width ≤ 300μs, Duty cycle ≤ 2%.

2. Essentially independent of operating temperature.

■ TEST CIRCUITS AND WAVEFORMS

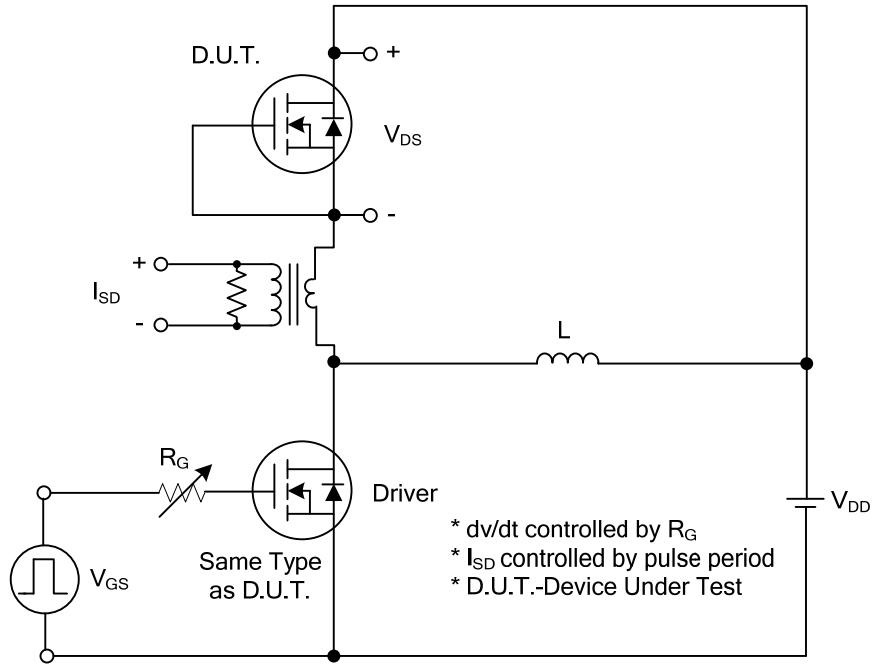

Peak Diode Recovery dv/dt Test Circuit

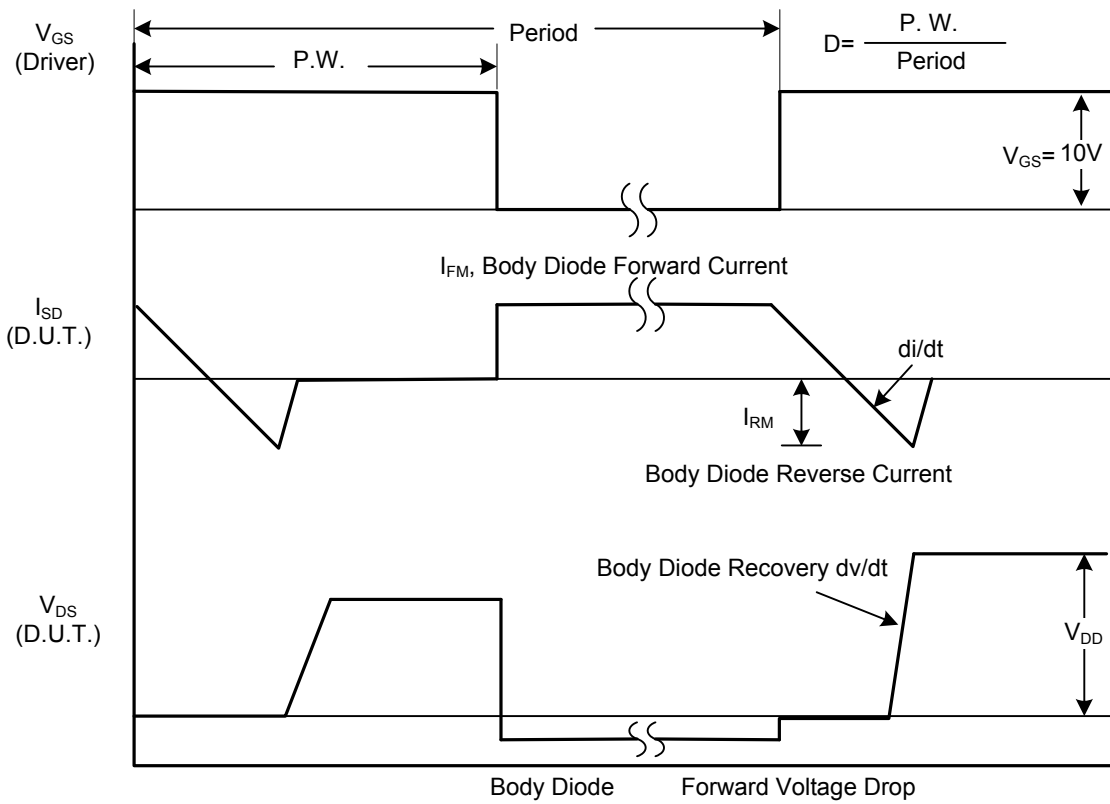

Peak Diode Recovery dv/dt Waveforms

■ TEST CIRCUITS AND WAVEFORMS(Cont.)

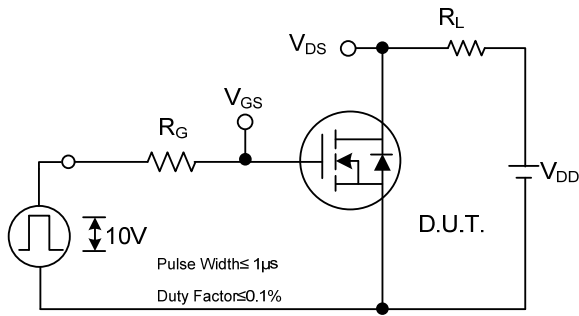

Switching Test Circuit

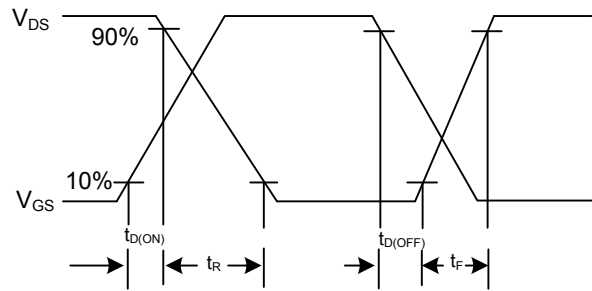

Switching Waveforms

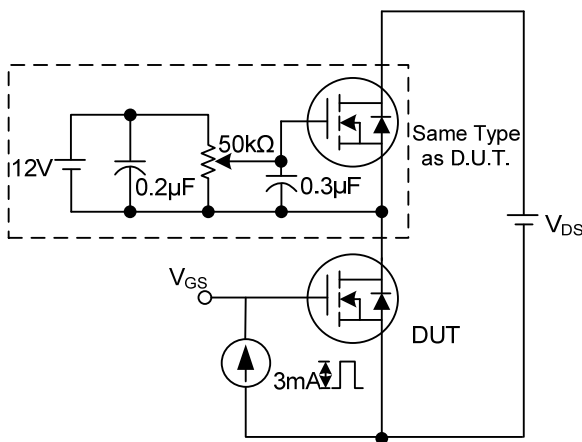

Gate Charge Test Circuit

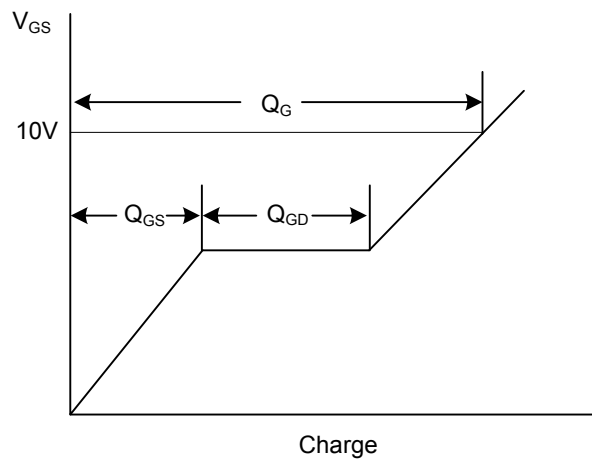

Gate Charge Waveform

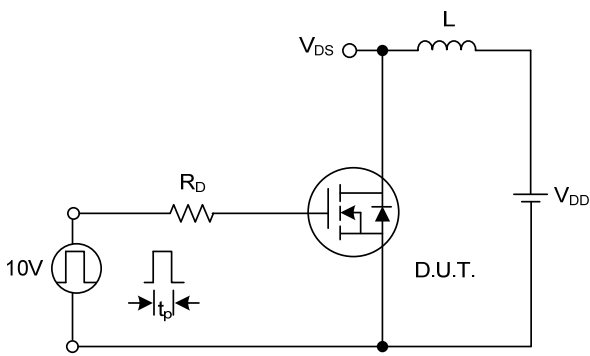

Unclamped Inductive Switching Test Circuit

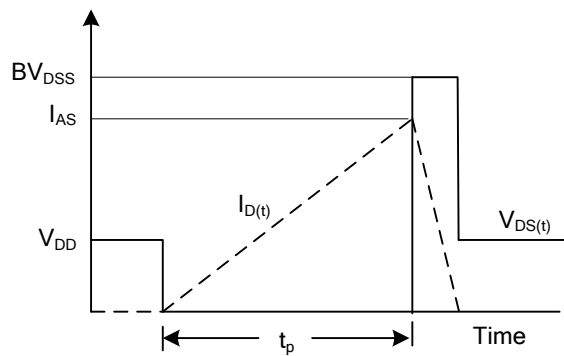

Unclamped Inductive Switching Waveforms

■ TYPICAL CHARACTERISTICS

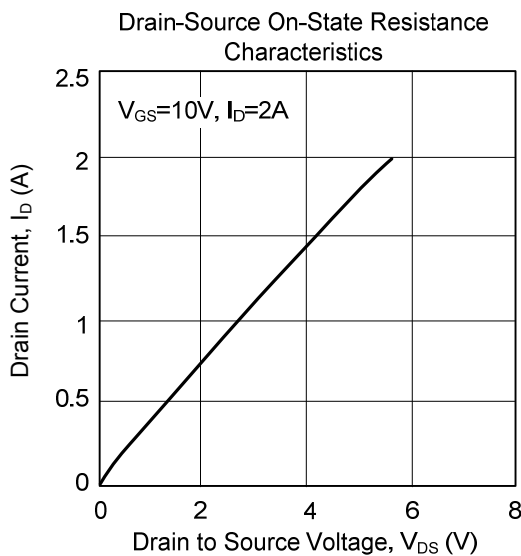
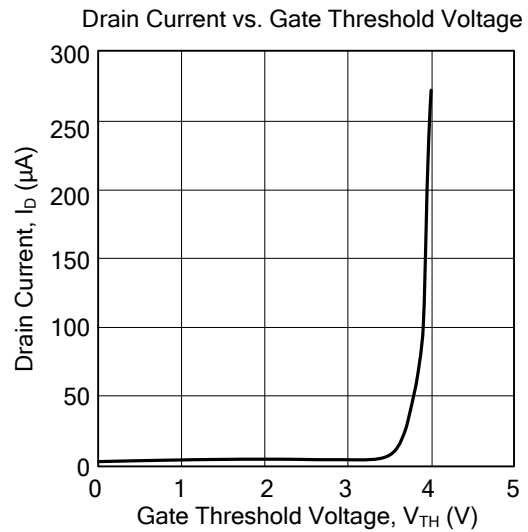
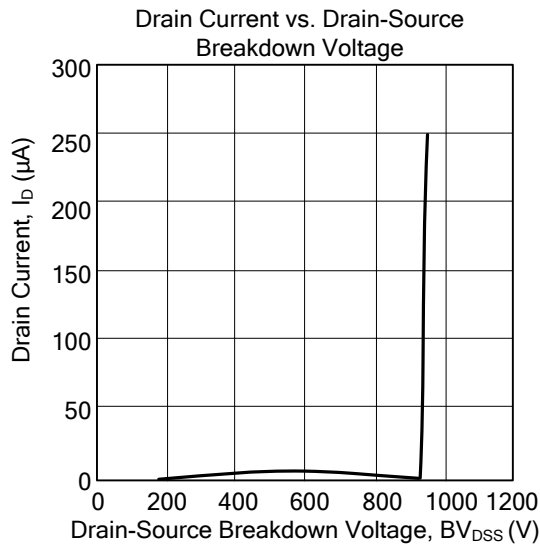

UTC assumes no responsibility for equipment failures that result from using products at values that exceed, even momentarily, rated values (such as maximum ratings, operating condition ranges, or other parameters) listed in products specifications of any and all UTC products described or contained herein. UTC products are not designed for use in life support appliances, devices or systems where malfunction of these products can be reasonably expected to result in personal injury. Reproduction in whole or in part is prohibited without the prior written consent of the copyright owner. The information presented in this document does not form part of any quotation or contract, is believed to be accurate and reliable and may be changed without notice.

X-ON Electronics

Largest Supplier of Electrical and Electronic Components

Click to view similar products for [MOSFET](#) category:

Click to view products by [Unisonic](#) manufacturer:

Other Similar products are found below :

[IRFD120](#) [JANTX2N5237](#) [2SK2267\(Q\)](#) [BUK455-60A/B](#) [TK100A10N1,S4X\(S](#) [MIC4420CM-TR](#) [VN1206L](#) [NDP4060](#) [SI4482DY](#)
[IRS2092STRPBF-EL](#) [IPS70R2K0CEAKMA1](#) [TK31J60W5,S1VQ\(O](#) [TK31J60W,S1VQ\(O](#) [TK16J60W,S1VQ\(O](#) [2SK2614\(TE16L1,Q\)](#)
[DMN1017UCP3-7](#) [EFC2J004NUZTDG](#) [P85W28HP2F-7071](#) [DMN1053UCP4-7](#) [NTE2384](#) [DMC2700UDMQ-7](#) [DMN2080UCB4-7](#)
[DMN61D9UWQ-13](#) [US6M2GTR](#) [DMN31D5UDJ-7](#) [DMP22D4UFO-7B](#) [IPS60R3K4CEAKMA1](#) [DMN1006UCA6-7](#) [DMN16M9UCA6-7](#)
[STF5N65M6](#) [IRF40H233XTMA1](#) [STU5N65M6](#) [DMN6022SSD-13](#) [DMN13M9UCA6-7](#) [DMTH10H4M6SPS-13](#) [IPS60R360PFD7SAKMA1](#)
[DMN2990UFB-7B](#) [SSM3K35CT,L3F](#) [IPLK60R1K0PFD7ATMA1](#) [2N7002W-G](#) [MCAC30N06Y-TP](#) [IPWS65R035CFD7AXKSA1](#)
[MCQ7328-TP](#) [SSM3J143TU,LXHF](#) [DMN12M3UCA6-7](#) [PJMF280N65E1_T0_00201](#) [PJMF380N65E1_T0_00201](#)
[PJMF280N60E1_T0_00201](#) [PJMF600N65E1_T0_00201](#) [PJMF900N65E1_T0_00201](#)